

PAPER 17

INTELLIGENCE  
EFFICIENCY  
PROFITABILITY  
PERFORMANCE INDICATORS  
RISK MANAGEMENT

GROUP IV ■ FINAL COURSE

# STRATEGIC PERFORMANCE MANAGEMENT (SPM)



The Institute of Cost Accountants of India  
(Statutory body under an Act of Parliament)

[www.icmai.in](http://www.icmai.in)

# STRATEGIC PERFORMANCE MANAGEMENT

FINAL

## STUDY NOTES



**The Institute of Cost Accountants of India**

CMA Bhawan, 12, Sudder Street, Kolkata - 700 016

**First Edition** : May 2013

**Second Edition** : October 2013

**Second Edition (Reprint)** : April 2014

**Third Edition (Reprint)** : August 2014

**Published by :**

Directorate of Studies

The Institute of Cost Accountants of India (ICAI)

CMA Bhawan, 12, Sudder Street, Kolkata - 700 016

[www.icmai.in](http://www.icmai.in)

**Printed at :**

Das Printers

61, Surya Sen Street,

Kolkata - 700 009

---

Copyright of these Study Notes is reserved by the Institute of Cost Accountants of India and prior permission from the Institute is necessary for reproduction of the whole or any part thereof.

---

# Syllabus

## Syllabus Structure

The syllabus comprises the following topics and study weightage:

A	Performance Management	60%
B	IT & Econometric tool in Performance Management	20%
C	Enterprise Risk Management	20%

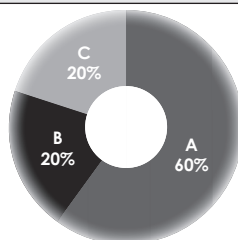

## ASSESSMENT STRATEGY

There will be written examination paper of three hours

## OBJECTIVES

To understand the tools for application and measurement of performance for strategic decision making.  
To develop and present appropriate strategies taking into consideration the risk profile of the organization

## Learning Aims

The syllabus aims to test the student's ability to:

- Understand the relevance of performance management for strategic decision-making
- Develop skill to interpret, evaluate and recommend strategies for decision making to have competitive advantage
- Apply Information Technology (IT) – based and Econometric tools for performance management
- Evaluate the risks associated with strategies of an organization

## Skill set required

Level C: Requiring skill levels of knowledge, comprehension, application, analysis, synthesis and evaluation.

<b>Section A : Performance Management</b>	<b>60%</b>
1. Conceptual Framework of Performance Management	
2. Performance Evaluation	
3. Strategic Performance Evaluation and Management Tools	
4. Strategic Reasoning and Decision Analysis	
5. Economic efficiency of the firm – impact analysis on performance	
6. Financial Performance Indicators (FPIs) and Non-financial Performance Indicators (NFPIs) for Profitability	
<b>Section B : IT &amp; Econometric tool in Performance Management</b>	<b>20%</b>
7. Application of IT and Econometric tools in Performance Management	
<b>Section C : Enterprise Risk Management</b>	<b>20%</b>
8. Enterprise Risk Management	
9. Performance Evaluation and Corporate Failure	

## SECTION A: PERFORMANCE MANAGEMENT [60 MARKS ]

### 1. Conceptual Framework of Performance Management

- (a) Performance Management- concept, components and related matrices

- (b) Performance, Productivity and Efficiency
- (c) Strategic assessment, business environment analysis
- (d) Competitive intelligence, communication of strategy, result analysis
- (e) Financial performance analysis
- (f) Process analysis
- (g) Supply Chain Management (SCM)
- (h) Customer Relationship Management (CRM) - Customer Profitability analysis; Customer intelligence, Customer Satisfaction Index (CSI), etc

**2. Performance Evaluation**

- (a) Divisional Profitability
- (b) Human productivity and performance analysis
- (c) Return on investment
- (d) The distinction between economic and managerial performance evaluation
- (e) Economic value added (residual income)
- (f) Transfer Pricing (including cost-plus, market, negotiated and dual prices)
- (g) Interaction of Transfer Pricing and Taxation – post-evaluation of strategic business arrangements

**3. Strategic Performance Evaluation and Management Tools**

- (a) Bench marking
- (b) Business process re-engineering
- (c) Value Chain–understanding of all chain of activities and the value gained at each
- (d) Activity, Porter's Value Chain Management Evaluation and Performance Analysis of strategic decisions executed through :
  - (i) Target Costing -profit planning and cost management
  - (ii) Activity Based Management -understand cost to improve customers value
  - (iii) Life cycle costing
- (e) Lean Management; Process Mapping

**4. Strategic Reasoning and Decision Analysis**

- (a) Game theory – introduction, extensive form games, Normal form games
- (b) Decision trees
- (c) Attitude towards risk
- (d) The expected value of perfect information

**5. Economic efficiency of the firm – impact analysis on performance**

- (a) Profit-maximization under different market structure
- (b) Market factors affecting Pricing decisions
- (c) Product policies-product line ( extent and mix); promotion strategies, branding strategies; distribution strategies

**6. Financial Performance Indicators (FPIs) and Non-financial Performance Indicators (NFPIs) for Profitability**

- (a) Key indicators – for measuring financial performance and non-financial performance
- (b) Methods for improvement of productivity and profitability

- (c) Balance Score Card

## **SECTION B: IT & ECONOMETRIC TOOL IN PERFORMANCE MANAGEMENT [20 MARKS]**

### **7. Application of IT and Econometric tools in Performance Management**

- (a) Impact of developments in information technology and e-commerce
- (b) Data Availability (Capturing relevant data which is interpretable); Data envelopment analysis (DEA); Data Mining (DM) Data Quality (How technology and IT applications are efficient in ensuring data quality)
- (c) Artificial neural networks
- (d) Six Sigma (SS)
- (e) Statistical quality control (SQL)
- (f) Stochastic frontier analysis (SFA); Fuzzy Sets Theory (FST); Malmquist Index (MI)
- (g) Principal Component Analysis (PCA)
- (h) Total Productivity Management (TPM)
- (i) Supply Chain Management (SCM)
- (j) Software tools (Spread sheets to BI applications)
- (k) Different resources of technology: Data Warehouse, Business Intelligence Systems,
- (l) Scorecards and Dashboards, Decision Support Systems, Management Information Systems, OLAP - Online Analytical Processing tools

## **SECTION C: ENTERPRISE RISK MANAGEMENT [20 MARKS]**

### **8. Enterprise Risk Management**

- (a) Risk Management
  - Risk Management – Introduction and objectives
  - Risk Measurement – Pooling, Diversification, Total Loss Distribution, Ruin Probability
  - Risk Analysis – risk mapping and key risk indicators
- (b) Corporate Risk Management
  - Risk Management and Shareholders
  - Risk Retention/Reduction
  - Asset/Liability Management
  - Project Risk Management, Enterprise Risk Management
  - Value at Risk (VAR), Basel – I, II & III (proposed)

### **9. Performance Evaluation and Corporate Failure**

- (a) Identify key-indicators for assessment of corporate failure
- (b) Application of generally accepted cost accounting techniques and tools for analyzing quantitative and qualitative performance measurement
- (c) Strategic measures to prevent Corporate Failures, Prediction Models used to assess corporate failure
- (d) Identify and discuss performance improvement strategies that may be adopted in order to prevent corporate failure
- (e) Impact of Long-term survival – for consideration of life-cycle issues
- (f) Identification and procedure of operational changes to performance management systems required to implement the performance improvement strategies.

# Content

## SECTION A – PERFORMANCE MANAGEMENT

### Study Note 1 : Conceptual Framework of Performance Management

1.1	Performance Management - Concepts, Components and Related Matrices	1.1
1.2	Performance, Productivity and Efficiency	1.8
1.3	Strategic Assessment, Business Environment Analysis	1.11
1.4	Competitive Intelligence, Communication of Strategy, Result Analysis	1.43
1.5	Financial Performance Analysis	1.55
1.6	Process Analysis	1.62
1.7	Supply Chain Management	1.66
1.8	Customer Relationship Management – Theory And Principles	1.83

### Study Note 2 : Performance Evaluation

2.1	Divisional Profitability	2.1
2.2	Human Productivity and Performance Analysis	2.7
2.3	Return on Investment (ROI) and Residual Income (RI)	2.25
2.4	The Distinction Between Economic and Managerial Performance Evaluation	2.29
2.5	Economic Value Added (Residual Income)	2.30
2.6	Transfer Pricing	2.62
2.7	Interaction of Transfer Pricing and Taxation- Post Evaluation of Strategic Business Arrangements	2.80

### Study Note 3 : Strategic Performance Evaluation and Management Tools

3.1	Benchmarking	3.1
3.2	Business Process Re-engineering	3.16
3.3	Value Chain Analysis	3.31
3.4	Activity, Porter's Value Chain Management Evaluation and Performance Analysis of Strategic Decisions Executed through	3.47
	(i) Target Costing - Profit Planning & Cost Management	
	(ii) Activity Based Management - Understand Cost to Improve Value	
	(iii) Life Cycle Costing	
3.5	Lean Management & Process Mapping	3.103

#### **Study Note 4 : Strategic Reasoning and Decision Analysis**

4.1	Game Theory (Normal Form and Extensive Form)	4.1
4.2	Decision Trees	4.39
4.3	Attitude towards Risk	4.47
4.4	Expected Value of Perfect Information	4.52

#### **Study Note 5 : Economic Efficiency of the Firm - Impact Analysis on Performance**

5.1	Profit Maximization under Different Market Structure	5.1
5.2	Pricing Policies	5.6
5.3	Product Policies	5.46

#### **Study Note 6 : Financial and Non-Financial Performance Indicators and Profitability**

6.1	Key Indicators for measuring Financial Performance and Non-Financial Performance	6.1
6.2	Methods for Improvement of Productivity & Profitability	6.23
6.3	Balanced Score Card	6.38

## **SECTION B – IT & ECONOMETRIC TOOL IN PERFORMANCE MANAGEMENT**

#### **Study Note 7 : Application of IT and Econometric Tools in Performance Management**

7.1	Impact of Developments in Information Technology and E-Commerce	7.1
7.2	Data Availability, Data Envelopment Analysis(DEA), Data Mining (DM) & Data quality	7.9
7.3	Artical Neural Network (ANN)	7.36
7.4	Six Sigma	7.47
7.5	Statistical Quality Control (SQC)	7.50
7.6.	Stochastic Frontier Analysis (SFA), Fuzzy Sets Theory (FST) & Malm Quist Index (MI)	7.53
7.7	Principal Component Analysis (PCA)	7.57
7.8	Total Productivity Management (TPM)	7.59
7.9	Supply Chain Management (SCM)	7.63
7.10	Software Tools (Spread sheets to BI Application)	7.77



7.11	Different Resources of Technology - Data warehouse, Business Intelligence System	7.81
7.12	Scorecards and Dashboard, Decision Support Systems, Management Information Systems, OLAP - Online Analytical Processing Tools	7.87

## SECTION C – ENTERPRISE RISK MANAGEMENT

### Study Note 8 : Enterprise Risk Management

8.1	Risk Management	8.1
8.2	Corporate Risk Management	8.14

### Study Note 9 : Performance Evaluation and Corporate Failure

9.1	Corporate Failure	9.1
9.2	Application of Generally Accepted Cost Accounting Techniques and Tools for Analyzing Quantitative and Qualitative Performance Measurement	9.2
9.3	Leading Indicators of Sickness	9.6
9.4	The Prevalence of Corporate Failure	9.7
9.5	Causes of Corporate Failure and their examples	9.11
9.6	Preventing Corporate Failures	9.15
9.7	Prediction Models Used to Assess Corporate Failure	9.15
9.8	The Models to Predict Corporate Failure	9.26
9.9	Performance Improvement Strategies	9.29



## **Section A**

# **Performance Management**





# Study Note - 1

## CONCEPTUAL FRAMEWORK OF PERFORMANCE MANAGEMENT



### *This Study Note includes*

- 1.1 Performance Management - Concepts, Components and Related Matrices
- 1.2 Performance, Productivity and Efficiency
- 1.3 Strategic Assessment, Business Environment Analysis
- 1.4 Competitive Intelligence, Communication of Strategy, Result Analysis
- 1.5 Financial Performance Analysis
- 1.6 Process Analysis
- 1.7 Supply Chain Management
- 1.8 Customer Relationship Management - Theory and Principles

### 1.1 PERFORMANCE MANAGEMENT - CONCEPTS, COMPONENTS AND RELATED MATRICES

Sally is a sales manager at a large pharmaceutical company. The fiscal year will end in one Week. She is overwhelmed with end-of-the year tasks including reviewing the budget she is likely to get for next year, responding to phone calls of customers, and supervising a Group of 10 salespeople. It's a very hectic time, probably the most hectic time of the year. She receives a phone call from the HR Department: 'Sally, we have not received your performance reviews for your 10 employees; they are due by the end of the fiscal year.' Sally thinks 'Oh, those performance reviews... What a waste of my time!' From Sally's point of view, there is no value in filling out those meaningless forms. She does not see her subordinates in action because they are in the field visiting customers most of the time. All she knows about their performance is based on sales figures, which depend more on the products offered and geographic territory covered than the effort and motivation of each salesperson. And nothing happens in terms of rewards regardless of her ratings. These are lean times in her organization, and salary adjustments are based on seniority rather than merit. She has less than 3 days to turn in her forms. What is she going to do? She decides to go down the path of least resistance: to please her employees, she gives everyone the maximum possible rating. In this way, she believes they will be happy with their ratings, and Sally will not have to deal with complaints or follow-up meetings. Sally fills out the forms in less than 20 minutes and gets back to her 'real job'.

There is something very wrong with this picture, which, unfortunately, is a frequent situation in many organizations. Although Sally's HR department calls this process 'performance Management', it is not.

Performance management is a continuous process of identifying, measuring and developing performance in organizations by linking each individual's performance and objectives to the organization's overall mission and goals. Let's consider each of the definition's two main components:

1. **Continuous process:** Performance management is ongoing. It involves a never-ending process of setting goals and objectives, observing performance, and giving and receiving ongoing coaching and feedback.
2. **Link to mission and goals:** Performance management requires managers to ensure that employees' activities and outputs are congruent with the organisation's goals and, consequently, help the organisation gain a competitive business advantage. Performance Management therefore creates a direct link between employee performance and organizational goals, and makes the employees' contribution to the organization explicit.

Note that many organizations have what is labeled a 'performance management' system. However, we must distinguish between performance management and performance Appraisal.

"In a knowledge economy, organizations rely heavily on their intangible assets to build value. Consequently, performance management at the individual employee level is essential and the business case for implementing a system to measure and improve employee performance is strong." Management time and effort to increase performance not only meets this goal; it also decreases turnover rates. How do we manage performance within the organization? The most common part of the process, and the one with which we are most familiar, is the process of the performance appraisal, or evaluation. In this chapter, we will use the phrases performance evaluation, performance appraisal, and appraisal interchangeably. However, the performance appraisal process is not the only thing that's done in performance management.

Performance management is the process of identifying, measuring, managing, and developing the performance of the human resources in an organization. Basically we are trying to figure out how well employees perform and then to ultimately improve that performance level. When used correctly, performance management is a systematic analysis and measurement of worker performance (including communication of that assessment to the individual) that we use to improve performance over time.

Performance appraisal, on the other hand, is the ongoing process of evaluating employee performance. Performance appraisals are reviews of employee performance over time, so appraisal is just one piece of performance management.

The terms 'performance management' and 'performance appraisal' are sometimes used synonymously, but they are different. Performance management is a comprehensive, continuous and flexible approach to the management of organisations, teams and individuals which involves the maximum amount of dialogue between those concerned. Performance appraisal is a more limited approach which involves managers making top-down assessments and rating the performance of their subordinates at an annual performance appraisal meeting.

Performance appraisal	Performance management
Top-down assessment	Joint process through dialogue
Annual appraisal meeting	Continuous review with one or more formal reviews
Use of ratings	Ratings less common
Monolithic system	Flexible process
Focus on quantified objectives	Focus on values and behaviours as well as objectives
Often linked to pay	Less likely to be directly linked to pay
Bureaucratic - complex paperwork	Documentation kept to a minimum
Owned by the HR department	Owned by line managers

### 1.1.1 Performance Management - Concept

Performance Management System as a communications system designed to help employees succeed. It is directed by managers and supervisors but requires active participation by employees. The Performance Management System ensures that employees:

- are aware of their principal job functions,
- understand the level of performance expected,

## > 1.2 | STRATEGIC PERFORMANCE MANAGEMENT



- receive timely feedback about their performance,
- have opportunities for education, training and development, and
- receive performance ratings and rewards in a, fair and consistent manner.

Performance appraisal information is one consideration in making other personnel decisions such as promotions, performance-based disciplinary actions, and salary increases. Proposed personnel actions must be consistent with overall evaluations. Although there is a relationship between performance appraisals and determining employee eligibility for performance-based salary increases and bonuses, the System's primary focus is on managing employee performance towards the successful achievement of expectations set forth in the employee's work plan.

The Performance Management System applies to all permanent SPA employees who are regularly scheduled to work 20 hours or more each work week.

### **North Carolina Rating Scale**

Performance functions, expectations, and appraisals are guided by the five-point North Carolina Rating Scale

#### **Outstanding Performance (O)**

Performance is far above the defined job expectations. The employee consistently does outstanding work, regularly going far beyond what is expected of employees in this job. Performance that exceeds expectations is due to the effort and skills of the employee. Any performance not consistently exceeding expectations is minor or due to events not under the control of the employee.

#### **Very Good Performance (VG)**

Performance meets the defined job expectations and in many instances, exceeds job expectations. The employee generally is doing a very good job. Performance that exceeds expectations is due to the effort and skills of the employee.

#### **Good Performance (G)**

Performance meets the defined job expectations. The employee generally performs according to the expectations doing a good job. The employee is doing the job at the level expected for employees in this position. The good performance is due to the employee's own effort and skills.

#### **Below Good Performance (BG)**

Performance may meet some of the job expectations but does not fully meet the remainder. The employee generally is doing the job at a minimal level, and improvement is needed to fully meet the expectations. Performance is less than a good job. Lapses in performance are due to the employee's lack of effort or skills.

#### **Unsatisfactory Performance (U)**

Performance generally fails to meet the defined expectations or requires frequent, close supervision and/or the redoing of work. The employee is not doing the job at the level expected for employees in this position. Unsuccessful job performance is due to the employee's own lack of effort or skills.

There has been and is always a need for a management to assess time after time the progress towards the considered necessary and the desired goals of an organization. The employees are the integral part of an organization and they play a vital role in running the business, therefore, it is of a great essence to ensure if they fulfill their responsibilities to the best of their abilities and expectations. The management is at all times keen to make certain if the goals are unfailingly being met. If so, then, they are in an effective and efficient manner or not. Above and beyond, the management sees to it if there is a need to add the pertinent communication, coordination and action on the progress which is to be achieved so that it can help the organization in the attainment of its long term and strategic goals. With the aim of above activities to be performed smoothly, performance management has come into practice.

The process of performance management entails monitoring the progress of a business as well as measuring the performance of the employees in order that the corrective measures can be taken in case there are deviations. Without this conceptualized function, it is as though that a horse rider has submitted his will and wish to the horse and does not even bother it takes wherever it wills and wishes. As regards the organization, the management, not giving careful attention, doesn't monitor whether the organization performs well and leading itself towards growth or fails to do so. Thus, the implementation of performance management at any organizational level is indispensable.

It is through the process of performance management that the individual objectives are linked with the organizational objectives. Performance management concentrates on such tools that create the desired qualities in the employees in order to get the jobs done. In its most positive form, performance management will not only help the employees in understanding what is expected of them but also how they can contribute to achieving organizational goals. Development is not limited to the employees; it rather addresses the whole team. It builds the personalities of the employees and develops their necessary skills to allow them to reach to their full potentials so that there can be a great satisfaction in respect of jobs and skills, overall maximization and expansion of business, in terms of profits – organizational development, effectiveness and efficiency.

The Process undertaken by way of performance management should be regarded to be a sort of test and evidence to the desirable qualities and the integrity of the employees as well as to their shortcomings. Just as the capacity and the acquired knowledge of students is tested through their exams so that they may be aware of what they possess and what is needed to improve and that they may get maximum percentage of marks in case of their lower performance, performance management takes on its process through which the employees of the organization can excel in their abilities and performance at work. They can enhance their skills and competencies. Above and beyond, they can be aware of their shortcomings while they will be able to focus on their possible areas of improvement.

Performance management is carried out continuously- it is not one time action. It favors effective communication and relevant coordination with timely feedbacks in relation to the organizational goals. Feedback is the process of communicating the evaluations to the concerned authorities while evaluation is of much use to know what is being done and whether it is being done in an appropriate manner so as to proceed for further corrective actions. In this way, performance management is meant to evaluate employees' performance at work in terms of predetermined standards in order that a sound system, by submitting the reports to the appropriate authorities, may be established. It is through this system the eligible employees may be rewarded as well as the employees whose performance is lower than the expected standards may become aware of their weaknesses and inefficiencies.

Performance management focuses mainly on the achievement of results. It differentiates the aspects, such as being engaged and producing results- which means, being busy should not necessarily be indicating that the results are being produced. There may be times when employees seem to be very busy but in terms of their performance, the results are in contrast to what has been expected. Systematic performance appraisal provides much assistance in assessing the potentials of the employees. Thus, performance management directs and leads the business to the overall achievement with the assessment of employees' effectiveness by the implementation of performance appraisals at regular intervals.

### The Performance Management Cycle

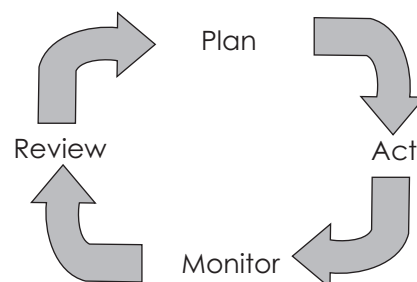



### 1.1.2 Components of Performance Management:

- 1. Performance Planning:** Performance planning is the first crucial component of any performance management process which forms the basis of performance appraisals. Performance planning is jointly done by the appraisee and also the reviewer in the beginning of a performance session. During this period, the employees decide upon the targets and the key performance areas which can be performed over a year within the performance budget, which is finalized after a mutual agreement between the reporting officer and the employee.
- 2. Performance Appraisal and Reviewing:** The appraisals are normally performed twice in a year in an organization in the form of mid reviews and annual reviews which is held at the end of the financial year. In this process, the appraisee first offers the self filled up ratings in the self appraisal form and also describes his/her achievements over a period of time in quantifiable terms. After the self appraisal, the final ratings are provided by the appraiser for the quantifiable and measurable achievements of the employee being appraised. The entire process of review seeks an active participation of both the employee and the appraiser for analyzing the causes of loopholes in the performance and how it can be overcome.
- 3. Feedback on the Performance followed by personal counseling and performance facilitation:** Feedback and counseling is given a lot of importance in the performance management process. This is the stage in which the employee acquires awareness from the appraiser about the areas of improvements and also information on whether the employee is contributing the expected levels of performance or not. The employee receives an open and a very transparent feedback and along with this the training and development needs of the employee is also identified. The appraiser adopts all the possible steps to ensure that the employee meets the expected outcomes for an organization through effective personal counseling and guidance, mentoring and representing the employee in training programs which develop the competencies and improve the overall productivity.
- 4. Rewarding good performance:** This is a very vital component as it will determine the work motivation of an employee. During this stage, an employee is publicly recognized for good performance and is rewarded. This stage is very sensitive for an employee as this may have a direct influence on the self esteem and achievement orientation. Any contributions duly recognized by an organization helps an employee in coping up with the failures successfully and satisfies the need for affection.
- 5. Performance Improvement Plans:** In this stage, fresh set of goals are established for an employee and new deadline is provided for accomplishing those objectives. The employee is clearly communicated about the areas in which the employee is expected to improve and a stipulated deadline is also assigned within which the employee must show this improvement. This plan is jointly developed by the appraisee and the appraiser and is mutually approved.
- 6. Potential Appraisal:** Potential appraisal forms a basis for both lateral and vertical movement of employees. By implementing competency mapping and various assessment techniques, potential appraisal is performed. Potential appraisal provides crucial inputs for succession planning and job rotation.

### 1.1.3 Performance Matrices.

Performance management metrics are statistics designed to quantify selected aspects of an organization's performance so that management can better monitor, control, and take corrective action. The basic mantra is you cannot manage what you do not measure. Business performance management software is widely available to assist with the routine measurement task. Historically, **performance metrics** focused on the interests of owners, and hence an organization's financial performance. Over the past two decades, that narrow focus has broadened to include non-financial metrics.

Financial performance is tracked using a battery of individual line items reported in three major financial statements — the profit and loss, **balance sheet**, and **cash flow** statements. These line items include



sales, cost of goods sold, tax expense, profit after tax, total assets, capital expenditure, and cash flow from operations. Financial line items are used to calculate a litany of financial ratios.

Key areas covered by financial ratios include the profitability of sales, efficiency of costs, strength of cash flow, structure of capital employed, and the profitability of that capital. Apart from management, the main audience for these metrics is shareholders, the owners of a firm.

Within private sector firms normally focused on profit maximization, the ultimate objective of financial metrics is to increase the firm's value and hence the wealth of shareholders. This objective, in turn, ultimately depends on two key metrics: the size of a firm's capital base and the rate of profitability earned by the firm on that capital. The many and varied financial ratios all assist in understanding these two key value drivers.

During the 1980s, organization leaders expressed an interest in having available performance management metrics that extended beyond the financial, and which addressed all stakeholders. Employees, customers, and the public began to call for increased transparency into organizations. This, it was believed, would allow them to better assess how organizations affected them, both individually and collectively, through impacts on community assets and the environment.

To help meet that need, the balanced scorecard was developed as a performance management tool during the early 1990s by Drs. Robert Kaplan and David Norton. In addition to financial performance, balanced scorecard metrics cover three other broad themes: the customer, the business process, plus learning and growth. It is a comprehensive framework aimed at assisting organizations to scrutinize performance, align activities with vision and strategy, and, importantly, improve communication with all stakeholders. As the name implies, the balanced scorecard provides a more balanced set of performance management metrics.

Performance management metrics are used by organizations across all sectors of the economy — private, government, and not-for-profit. Given that the visions and goals of organizations varies greatly across these sectors, so too do the performance management metrics they choose. The selection of appropriate metrics always involves four basic steps: identify important issues that deserve measurement, develop relevant metrics, set appropriate targets, and monitor and manage performance towards the targets.

Performance measurement is an important cornerstone of the contracts between the University of California and the U.S. Department of Energy for the operation of its laboratories. Performance metrics should be constructed to encourage performance improvement, effectiveness, efficiency, and appropriate levels of internal controls. They should incorporate “best practices” related to the performance being measured and cost/risk/benefit analysis, where appropriate.

The Department of Energy has promulgated a set of Total Quality Management guidelines that indicate that performance metrics should lead to a quantitative assessment of gains in:

• Customer Satisfaction	• Organizational Performance	• Workforce Excellence
-------------------------	------------------------------	------------------------

The key elements of the performance metrics to these guidelines should address:

• Alignment with Organizational Mission	• Cost Reduction and/or Avoidance	• Meeting DOE Requirements
• Quality of Product	• Cycle Time Reduction	• Meeting Commitments
• Timely Delivery	• Customer Satisfaction	

**The Process**

The first step in developing performance metrics is to involve the people who are responsible for the work to be measured because they are the most knowledgeable about the work. Once these people are identified and involved, it is necessary to:

1. Identify critical work processes and customer requirements.



2. Identify critical results desired and align them to customer requirements.
3. Develop measurements for the critical work processes or critical results.
4. Establish performance goals, standards, or benchmarks.

The establishment of performance goals can best be specified when they are defined within three primary levels:

**Objectives:** Broad, general areas of review. These generally reflect the end goals based on the mission of a function.

**Criteria:** Specific areas of accomplishment that satisfy major divisions of responsibility within a function.

**Measures:** Metrics designed to drive improvement and characterize progress made under each criteria. These are specific quantifiable goals based on individual expected work outputs.

The SMART test is frequently used to provide a quick reference to determine the quality of a particular performance metric:

**S = Specific:** clear and focused to avoid misinterpretation. Should include measure assumptions and definitions and be easily interpreted.

**M = Measurable:** can be quantified and compared to other data. It should allow for meaningful statistical analysis. Avoid "yes/no" measures except in limited cases, such as start-up or systems-in-place situations.

**A = Attainable:** achievable, reasonable, and credible under conditions expected.

**R = Realistic:** fits into the organization's constraints and is cost-effective.

**T = Timely:** doable within the time frame given.

### Types of Metrics

Quality performance metrics allow for the collection of meaningful data for trending and analysis of rate-of-change over time. Examples are:

<ul style="list-style-type: none"> <li>• Trending against known standards: the standards may come from either internal or external sources and may include benchmarks.</li> </ul>
<ul style="list-style-type: none"> <li>• Trending with standards to be established: usually this type of metric is used in conjunction with establishing a baseline.</li> </ul>
<ul style="list-style-type: none"> <li>• Milestones achieved.</li> </ul>

Yes/No metrics are used in certain situations usually involving establishing trends, baselines, or targets, or in start-up cases. Because there is no valid calibration of the level of performance for this type of measure, these should be used sparingly. Examples are:

<ul style="list-style-type: none"> <li>• Establish/implement a system.</li> </ul>	<ul style="list-style-type: none"> <li>• Reporting achieved (without analyses).</li> </ul>
<ul style="list-style-type: none"> <li>• System is in place (without regard to effectiveness).</li> </ul>	<ul style="list-style-type: none"> <li>• Threshold achieved (arbitrary standards).</li> </ul>
<ul style="list-style-type: none"> <li>• Analysis performed (without criteria).</li> </ul>	

**Determining the Quality of Metrics:** The following questions serve as a checklist to determine the quality of the performance metrics that have been defined.

1. Is the metric objectively measurable?
2. Does the metric include a clear statement of the end results expected?
3. Does the metric support customer requirements, including compliance issues where appropriate?
4. Does the metric focus on effectiveness and/or efficiency of the system being measured?

5. Does the metric allow for meaningful trend or statistical analysis?
6. Has appropriate industry or other external standards been applied?
7. Does the metric include milestones and/or indicators to express qualitative criteria?
8. Are the metrics challenging but at the same time attainable?
9. Are assumptions and definitions specified for what constitutes satisfactory performance?
10. Have those who are responsible for the performance being measured been fully involved in the development of this metric?
11. Has the metric been mutually agreed upon by you and your customers?

## 1.2 PERFORMANCE, PRODUCTIVITY AND EFFICIENCY

The concepts of productivity and efficiency have received a great deal of attention in many countries and organizations and by individuals in recent years. In an organizational context, productivity and efficiency reflects overall performance. This could lead to increases or decreases in shareholders' wealth. Hence, governments, economists and professionals are concerned with defining and measuring the concepts of productivity and efficiency.

At a basic level, productivity examines the relationship between input and output in a given production process. Thus, productivity is expressed in an output versus input formula for measuring production activities. It does not merely define the volume of output, but output obtained in relation to the resources employed. In this context, the productivity of the firm can be defined as a ratio as shown in equation 1.

$$\text{Productivity} = \frac{\text{Output(s)}}{\text{Input(s)}} \quad \dots\dots\dots (1)$$

The concept of productivity is closely related with that of efficiency. While the terms productivity and efficiency are often used interchangeably, efficiency does not have the same precise meaning as does productivity. While efficiency is also defined in terms of a comparison of two components (inputs and outputs), the highest productivity level from each input level is recognized as the efficient situation. Further suggest that efficiency reflects the ability of a firm to obtain maximum output from a given set of inputs. If a firm is obtaining maximum output from a set of inputs, it is said to be an efficient firm.

Alternative ways of improving the productivity of the firm, for example, are by producing goods and services with fewer inputs or producing more output from the same quantity of inputs. Thus, increasing productivity implies either more output is produced with the same amount of inputs or that fewer inputs are required to produce the same level of output. The highest productivity (efficient point) is achieved when maximum output is obtained for a particular input level. Hence, productivity growth encompasses changes in efficiency, and increasing efficiency definitely raises productivity. Consequently, if the productivity growth of an organization is higher than that of its competitors, or other firms, that firm performs better and is considered to be more efficient.

On the other hand, performance is much bigger and more inclusive. In the business sector it is about improving all the factors that increase the profit—factors that reduce expenditure, increase income, and result in more output per unit input.

In the public sector it is about how you maximise the quality, scope and timeliness (waiting times) of your service delivery while minimising the inputs that are required. Ultimately, performance is about maximising the amount of output energy from a system.

Hence, Performance will be product of efficiency, utilisation and productivity.

## Types of Efficiency

Efficiency consists of two main components; technical efficiency and allocative efficiency. Generally, the term efficiency refers to technical efficiency. As discussed in the previous section, technical efficiency occurs if a firm obtains maximum output from a set of inputs.

Allocate efficiency occurs when a firm chooses the optimal combination of inputs, given the level of prices and the production technology. When a firm fails to choose the optimal combination of inputs at a given level of prices, it is said to be allocatively inefficient, though, it may be technically efficient. Technical efficiency and allocative efficiency combine to provide overall efficiency. When a firm achieves maximum output from a particular input level, with utilization of inputs at least cost, it is considered to be an overall efficient firm.

Improving productivity and efficiency is one of the main goals considered in organizations in recent years, because productivity gains provide overall information about the firm's performance. When considering efficiency analysis in financial institutions, Berger and Humphrey stress that it is important to determine their efficiency because they are in a competitive environment and their strength is vital for solvency. Further, efficiency analysis not only has important ramifications for institutions themselves, as evident in their competitiveness and solvency, it is also important for other interested parties, such as regulatory authorities and the general public. Although the basic concepts of productivity and efficiency are clearly discernible measures that have been presented in the literature are diverse. The selection of the appropriate measurement depends on the purpose of the study.

### 1.2.1 Measurement of Productivity and Efficiency

Basically, for a single firm that produces one output using a single input, the ratio of output to input is a measure of the productivity level. In this case, productivity is relatively easy to measure. However, in the case of many outputs and many inputs in a production process, the measurement of an output-input ratio is difficult. Hence, many different approaches have been applied by many researchers to the measurement of productivity and efficiency changes in various types of institutions, and levels of DMUs as well. Further, different approaches to productivity measurement give different numeric answers. Therefore, it is essential to select appropriate measurements for productivity and efficiency to avoid measurement bias in the results.

#### Partial Factor Productivity and Total Factor Productivity

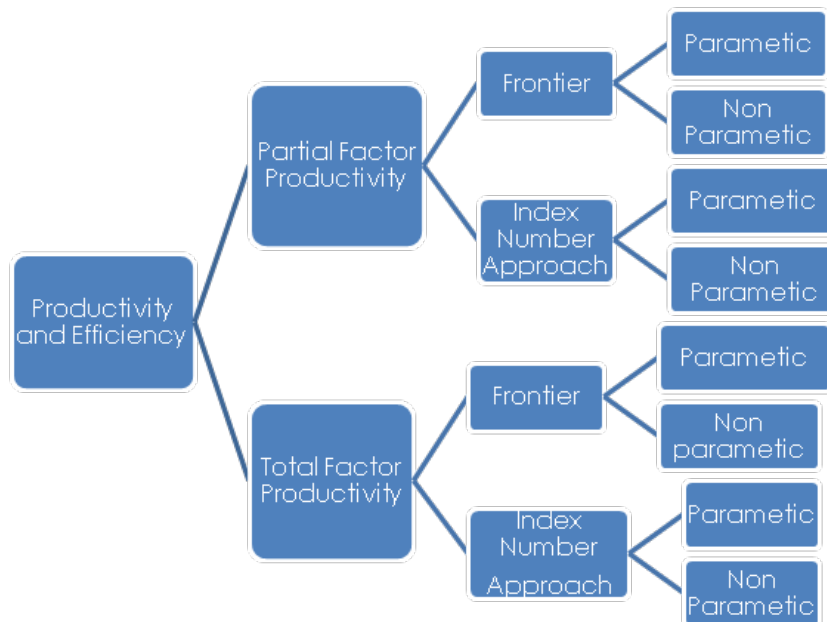

**Fig: Approaches to the measurement of Productivity and Efficiency**

The above summarizes the various approaches to the measurement of productivity and efficiency identified from the literature. In general, productivity and efficiency can be measured on a '**Partial**' factor or '**Total**' factor basis. **Partial Factor Productivity (PFP)** refers to the change in output owing to the change in the quantity of one input, whereas **Total Factor Productivity (TFP)** refers to the change in output owing to changes in the quantity of more than one input.

In general, in an industrial context, goods and services are produced by a combination of many factors or inputs. The output of goods and services cannot be used as a measure of the productivity of any one of the inputs. The output is only a measure of the joint power of inputs to achieve results. This is the main disadvantage of measuring productivity and efficiency using the PFP approach. To overcome this shortcoming of PFP, TFP has been developed. TFP measures overall productivity and efficiency by considering all inputs and all outputs in the production process. With full technical efficiency, producing maximum potential output from the allocated inputs.

### 1.2.2 Application of Input-Output

A variety of inputs and outputs are used to estimate the efficiency of financial institutions. In many industries, physical measures of inputs and outputs are readily available. In contrast, physical measures are not readily available in financial institutions (Humphrey 1991) and there is disagreement on the definition and measurement of inputs and outputs related to financial services; a problem still to be resolved in the literature. Hence, selection of input-output combinations in efficiency analysis of financial institutions has become crucial.

Berger and Humphrey (1997) provide a detailed discussion of problems involved in the selection of inputs and outputs to be used for evaluating the efficiency of financial institutions. They suggested two main approaches, namely the production and intermediation approaches that can be used to identify appropriate inputs and outputs in efficiency analysis. Furthermore, they suggest that the asset approach, the user cost approach and the value-added approach are also important in the measurement of efficiency. Similarly, Favero and Papi (1995) emphasize that the intermediation approach, the production approach, and the asset approach produce better input-output combinations than the other approaches in efficiency analysis. The intermediation approach, the production approach, and the asset approach have dominated the selection of inputs and outputs in the measurement of efficiency in the banking literature (Berger and Humphrey 1997).

The intermediation approach is appropriate for institutions where deposits are converted into loans. Funds are intermediated between savers and borrowers. Thus, deposits and loans are considered as outputs with loanable funds, interest expense and labour cost as inputs. This approach is used frequently in the literature for measuring efficiency in the banking industry. With the frontier analysis of efficiency, the intermediation approach is more suitable for the minimization of all costs to enable the maximization of profits. In addition, this approach is important to banking institutions because the interest expense is used as a key input as it often comprises two-thirds of the total costs of financial institutions.

The production approach views deposit taking institutions as producers of services for account holders. This approach assumes that these services are produced by utilizing capital and labour inputs (Berger and Humphrey 1997). Further, the production approach considers that financial institutions provide transactions on deposit accounts and also provide loans and advances. Thus, the number of accounts in different loans and deposit categories are generally taken to be the appropriate measures of outputs under this approach. Berger and Humphrey also stress this argument and suggest that the best measure of output is number and type of transactions for the period. However, this approach is inconvenient because all such data are not readily available. Hence, the production approach is more suitable for the evaluation of the relative efficiency of single branches within the institution. Further, the production approach places less emphasis on the transfer of funds as the bank's main role as a financial intermediary. In contrast, the intermediation approach evaluates the entire institution (Berger and Humphrey 1997).



The assets approach, the value-added approach and the user-cost approach provide guidelines on how to identify variables in different ways. According to assets approach, outputs are strictly defined by assets and mainly by the production of loans in which firms have advantages over other institutions in the industry. Under the asset approach, loans and other assets are considered as outputs, while deposits, other liabilities, labour and physical capital is considered as inputs.

Under the user cost approach, the net revenue generated by a particular asset or liability item determines whether the financial product is an input or an output. On the other hand, the value added approach considers that both liability and asset categories have same output characteristics. Nevertheless, only those categories that have substantial value added are treated as outputs while the others are treated as either inputs or intermediate products depending on the specific attributes of each category. The value added approach differs from the user cost approach in that it is based on actual operating cost data rather than determining these costs explicitly.

An overview of the approaches to productivity and efficiency measurement, particularly in financial institutions, the theoretical and empirical literature on productivity and efficiency is reviewed, with special reference to studies based on the DEA (Data Enveloped Management) technique.

### 1.3 STRATEGIC ASSESSMENT, BUSINESS ENVIRONMENT ANALYSIS

#### 1.3.1 Strategic Assessment

The best strategic positions are derived from a deep understanding of your customers, the products or services you should offer, and how best to deliver those products to your customers. Firms today must take full advantage of rich transactional data and market insights to develop winning strategies and out-behave the competition.

Every leader of every organization should periodically do a strategic assessment; and every leader of every organization should have a strategic plan that they intend to implement or are implementing. This is equally true for servant leaders. For a new organization these may be a part of the formal business plan. For existing organizations, they form the core of long-range strategic planning and are the blueprint or template for operational planning.

Here, we will describe a Strategic Assessment and Plan that may be utilized by any type of organization, be it a for-profit business or a not-for-profit organization. If it is a new organization, you may find that the assessment phases 1 and 2 are most helpful. If it is an existing organization, the assessment phases 1 & 2 will help you to identify your current state while the planning phases (3 and 4) will point you in the direction you want to go.

The Strategic Assessment and Plan has four phases.

The phases are:

Phase 1: Where are we?

Phase 2: Where do we want to go?

Phase 3: How are we going to get there?

Phase 4: Are we getting there?

#### Phase 1: Where are we?

In this assessment phase we will determine our mission, the leader's responsibilities, and analyze the environment in which our organization exists or functions. The first step is to determine our mission. What is our purpose, our reason for being? Mission involves what we do now, here in the present. It may change in the future, and probably will, but at least for now, this is what we do. At this point, don't worry too much about crafting a mission statement (assuming you don't have

one). That can come later. For now, focus on identifying what it is you do as an organization. Later on you can refine a succinct, coherent statement of your mission.

Next we ask what business are we in? This requires a wide-angle view of our mission and vision for the future. For example, had the railroad companies in the 19<sup>th</sup> century recognized that they were in the business of moving people and heavy, bulky products over long distances, today they would be vertically integrated with other means of transportation to include airlines, ships, and trucks. Instead, they saw themselves as providing “rail transportation” for people and things. Others own the airlines, shipping and trucking companies.

Who are our customers? Our “customers” are those individuals or organizations who receive our “products” whatever they may be, past, present, and future. Who are we serving now? Who would we like to serve in the future? Determining our customer’s needs will form the critical component of our future plan, i.e., how can we best meet those needs? Do we know our customer’s demographics? What about lost customers? Determining why customers do not return to your organization can be difficult and time-consuming but the answers can save you future defections. And since new customers can cost up to ten times the cost of retaining existing customers, it will be money well spent (Heebsh, 2006).

The second step in Phase 1 is to identify the leader’s responsibilities, leadership style and values. Ultimately, the leader is responsible for everything that the organization does or does not do. A couple of years ago a U.S. Navy nuclear submarine ran aground on an uncharted sandbar while running submerged. The captain was not at the helm yet he was held accountable and was relieved of his command when the boat returned to port. The U.S. Navy understands that the captain is ultimately responsible for the safe conduct of his vessel even when he is not physically overseeing its course; just so every organization. Does that mean that the leader should retain all responsibility unto himself and delegate nothing? Absolutely not, in fact the leader should seek to delegate all responsibilities except those few that he and he alone must do. This frees him up to concentrate on his most important tasks and creates future leaders who learn as they are delegated responsibility. Therefore, in this step we seek to identify those things that only the leader can do. The number of tasks in every organization will be small because most things can be delegated. Examples of leader-only functions might include: evaluating senior staff, administering the Sacraments, or working with senior community leaders.

Next, we examine leadership style. Recent stories in the business press have highlighted companies that are apparently pulling out of a downward spiral after replacing their celebrity CEOs. Under new, low-key, people-focused leaders who seek out the counsel of their subordinates, several major corporations are effecting a turnaround. As Jim Collins discovered in researching for his book, *Good to Great*, all of the eleven “great” CEOs were self-effacing, quiet and reserved yet driven for organizational success (Collins, 2001).

Discovering the leadership approach required of your subordinates means you must first determine each person’s level of competency and commitment. Competency refers to the level of expertise and efficiency for the task assigned. Someone who has multiple tasks may have multiple levels of competency; i.e., they may be very good at one task but less so at another. Evaluation of competency is task-specific. The degree of leader involvement is dependent upon the task and not the individual. In other words, you may need to be more involved in coaching and guiding some one who has low competency with a specific task but have little direct involvement with other tasks where their competency level is high.

The third and final step in Phase 1 is to analyze the environments in which an organization exists, internally and externally. This is often referred to as SWOT analysis: strengths and weaknesses (internally), and opportunities and threats (externally). What are our own organizational strengths? What are our distinctive competencies and our competitive advantage, i.e., what sets us apart from others that have the same or similar mission? For a business, this means asking why should a customer do business with us over one of our competitors?

An organization that cannot identify its competitive advantage is doomed to failure. So if you don’t know what your competitive advantage is, you might as well get out of business now and save yourself the headaches of certain failure in the future. But it may also include: location, availability and education of the workforce, cost control, quality level, worker satisfaction, use of



technology and the like. What are our weaknesses? These may include many of the same categories listed under strengths. We must be brutally honest here and seek to build on our strengths and mitigate our weaknesses.

As we look to the external environment, we identify our competitors and not only those who offer a similar product but also those who have a product that may be substituted for ours. For example, a company operating a golf driving range and batting cages needs to look beyond other driving ranges/batting cages and consider companies offering recreation services as potential competitors. What are the strengths and weaknesses of our competitors? Consider factors such as: location, level of technology, prices, reputation, longevity, community involvement, and customer service.

What are the barriers to entry to our business/industry? What are the opportunities and threats in the external environment? Is the local government a threat or an opportunity? Companies operating internationally will consider this as one of the major environmental factors. Consider other factors such as: number of competitors, regulations, environmental constraints, natural resources, transportation infrastructure and the state of the economy. Once we have done a thorough assessment of our current condition, we turn to the question of what do we want to become?

### **Phase 2: Where do we want to go?**

Here we look to the future by working through the next four steps to develop our vision and organizational values; identify key processes and systems; determine gaps in performance; and finally, establish objectives and goals.

You will recall that in Phase 1 we developed our mission, i.e., our purpose, our reason for being. Mission is what we do NOW; it is oriented to the present. Vision is what we hope to do in the future. It is a unifying picture of where the organization is going and enables everyone to focus on the same distant point on the horizon. Our mission may change as we move toward our vision over time but our vision should remain. Mission and vision form two elements of the organization's Guiding Principles. The third element is values, which will be discussed below (Sullivan, 2004).

Step 4 is development of the organizational vision and values. That vision should be a shared vision. It will not be effective as a guiding principle if it is only the leader's vision. The leader has an important role to play in visioning but his role cannot be as the sole author and enforcer of the vision. A vision statement crafted by a leader or even an executive group without input and critique from the people within the organization will not become a shared vision. Sorry, it just won't happen. So how do we achieve a shared vision?

People are more committed to decisions when they have been involved in the decision process. Even if an individual's opinions and ideas are not accepted along the path to a final decision, the fact that you listened to them and considered their input is vital to their commitment to implementation. Therefore it is important that as many people as possible in the organization have an opportunity to provide input on the organizational vision statement. Practically, how do you do that?

The third element in our organizational Guiding Principles is values, i.e., how will we treat each other and our "customers" (those we serve) on our way toward our vision? In the first phase, we discussed the leader's values and how they must examine their own set of values and how they relate to the organization. In this step, we are determining what those organizational values currently are, or if this is a new organization, what we want them to be. Organizational values that form and shape the organizational culture are often unspoken but are simply "the way we do things around here." A new leader coming in to an existing organization may be surprised to learn the dominant values practiced in the organization. What is down on paper and the "way things really work" may be two entirely different things. Ask lots of questions and values will emerge. It may take setting up a series of scenarios: if this happens, how do we deal with it? For example: What do we tell a customer when a shipment will be late especially if he represents a large percentage of our total sales?

How are we going to treat each other within the organization? What level of trust are we comfortable



with? For example, an organization that trusts and respects its employees will not hesitate to share its financial details. The company is saying, in effect: we trust you and respect your judgment and opinions such that we are willing to disclose our most intimate financial details with you since this is your company too! However, you must live out those values for them to become truly a part of the culture. Southwest Airlines is famous for its customer service. They live out their value of putting customers' needs first. However, if the day arrives where an employee is disciplined for taking too much time with a customer that value dies. The old value is replaced with "speed = profit" and the needs of customers move to the back of the line. So be careful what you say you value because your people will be watching to see if you really mean it.

Step 5 is to identify your key processes and systems. What are the few key systems and processes that differentiate us from our competitors and give us competitive advantage? Most organizations do lots of things but there are a few, select systems and processes that set the organization apart from others that are critical. We must do these well or we will not survive as an organization. The great football coach Vince Lombardi was very successful, in part, because he focused on the essentials: tackling and blocking. What is essential to the success of your organization? What are those systems and processes that are most important to its survival? For example, a liberal arts college must provide good, sound classroom instruction in order to survive. They do lots of other things but classroom instruction is critical to the future of the organization. Likewise, the manufacturing processes of an automobile maker are critical to its success. If they don't build a quality automobile, all the glib marketing in the world won't save it from ruin.

Step 6 is to determine the gaps in performance in our key systems and processes. We do this because we know that these systems and processes are essential to our survival and we must do them well. The Pareto Principle states that 80% of consequences stem from 20% of the causes (Reh, 2006). Therefore we should focus on those few essential systems and processes, as they will impact most of the other systems within the organization. First, we must gather data on our current level of performance in our key systems and processes. The metrics we choose are also critical since we must find what truly measures our effectiveness and that can take some time and trial. For example, the number of hours an employee spends in professional growth seminars is not a good metric for their level of training. What the person is able to do with the new knowledge is what you want to measure. Finding a metric that does that is the challenge. Once we feel that we have a good understanding of the steady state performance of our key systems, then we compare that condition with our desired future state. How do we determine what the standard should be? One way is to look to those organizations in whatever industry that consistently produce world-class results in a given area or system.

As we compare our key processes and systems against such standards, are there gaps in performance? In most cases, there will be. Now our task is to develop objectives and goals to close those gaps.

Step 7, the final step in Phase 2, is where we establish strategic and operational objectives that once obtained, will close the gaps in performance in our key systems and processes. The terms "objectives" and "goals" are sometimes used as interchangeably. Strategic objectives are those longer-term objectives that will take 3-5 years to complete. Operational objectives are to be completed within a year. An example of a strategic objective for a manufacturing company might be to develop new product lines for Eastern Europe. An operational objective supporting this could be to develop and market one new product for Eastern Europe.

Goals then are established under each objective that lead to completion of at least one element of that objective. These goals must be SMART: specific, measurable, achievable, results-oriented, and time-determined. For example:

Strategic Objective: Develop new product lines for Eastern Europe

Goal : Within 90 days, determine customer needs for our products and available suppliers within Eastern Germany



Each objective may have several goals. The more complex the objective the more goals we can expect. Objectives must support the mission and vision of the organization. Likewise, goals will support one or more objectives. Objectives that are not directly tied to furthering the organization's mission and vision should not be considered.

### **Phase 3: How are we going to get there?**

This phase, which has a single step, requires the development of an implementation plan and systems for monitoring performance.

Step 8 involves development of an implementation plan for the objectives and goals determined in Phase 2. Remember that each objective and its associated goal(s) are carefully selected to close a measurable gap between our current level of performance in key systems and processes and the desired future state. For each goal, we must determine:

- A. Who will be assigned responsibility for completion of the goal?
- B. What steps are to be accomplished?
- C. What resources will be made available?
- D. How should the work be accomplished?
- E. When do we want the goal completed?

Who will be held responsible for accomplishing the goal? This involves delegation of responsibility from a leader to a subordinate. This must be done since a task cannot simply be assigned to a group of people with the expectation that they will accept the responsibility and accomplish the task. Some one must be held directly responsible.

Successful delegation involves three elements: responsibility, authority and accountability. When a leader assigns responsibility for a task to a subordinate, he is, in effect, transferring his responsibility to that person. As discussed in Phase 1, the leader is responsible for everything the organization does or does not do. But he can and must delegate direct responsibility for tasks to

subordinates. In order for the person to effectively accomplish the task assigned, he must also receive the authority to call upon resources needed to accomplish the goal. Those resources may include people, material, technology, funds, equipment, time, or whatever is needed to get the job done. Finally, the person assigned will be held accountable for accomplishment of the task. Failure to perform a delegated task successfully is usually attributable to the leader's failure at delegating one of the essential elements. Often, that element is authority.

The steps to be accomplished are a series of events that must be completed in order for the goal to be realized. At this level they should be generalized while leaving the details to the person assigned and their team to determine. The same principle applies to the question of how should the work be accomplished. Leave the details to the leader and their team to determine how best to accomplish the steps. The resources needed to accomplish the task must be authorized or assigned by the senior leader whenever they exceed the normal level of authority of the delegated leader. This is best done in writing and formal notice given to other senior leaders in the organization of the delegated leader's authority and the duration of the task. This is especially important when people from another part of the organization may be required to assist in task accomplishment.

Assigning a date/time for goal accomplishment makes very clear to all when the job must be completed. If follow on tasks will depend upon completion of the task assigned, the person assigned and their team should also know this.

Finally we turn to the fourth phase where we will establish a review process for changing our strategic direction and ensuring that our plan stays fresh and relevant over time.

#### **Phase 4: Are we getting there?**

These two last steps involve monitoring performance, analyzing feedback, review and evaluation. This is the phase most often overlooked or underappreciated but critical to the success of our strategic plan. "What gets measured gets done," is an old but true proverb. Therefore, as discussed in Step 6, our choice of metrics is vitally important to goal achievement. Do we measure effectiveness, i.e., doing the right things, or efficiency, i.e., doing things right?

Step 9, therefore, is where we determine how we will measure objective/goal accomplishment and identify other means for progress feedback. This step is often overlooked because it is difficult and frequently frustrating to determine the measures that will tell you what you need to know. The fast and easy choices often don't measure our true success or failure. Finding the right metrics can be a process of trial and error. That's why it is necessary to frequently review and evaluate the data and its associated metric.

Selecting a quantitative and a qualitative metric may provide more realistic feedback than simply relying on a quantitative measurement alone. For example, measuring customer satisfaction with a product by tracking the number of complaints received for that product may only tell us part of the story. Talking with customers may reveal that problems with the product have caused customer defections to competing products. The customers are not complaining because they are no longer your customers!

Step 10 is review and evaluation. Here we determine the process for continued review of our progress on objective/goal accomplishment. How frequently will we review the data? What level of variation (deviation from plan) will cause us to change our implementation plan? What criteria will we use for changing strategic direction? How often will we review our mission and vision? What events would cause us to change? These questions need to be answered with broad participation throughout the organization.

#### **1.3.2 Business Environment Analysis**

"Environment factors of constraints are largely if not totally external and beyond the control of individual industrial enterprises and their arrangements. These are essentially the 'givers' within which firms and their managements must operate in a specific country and they vary, often greatly from country to country".

*Barry M. Richman and Melvyn Copen*

"The environment includes outside the firm which can lead to opportunities for or threats to the firm. Although, there are many factors, the most important of the sectors are socio – economic, technical, supplier, competitors, and government". Glueck and Jauch "Analysis is the critical starting point of strategic thinking"

*Kenichi Ohmae*

"It is not the strongest of the species that survive, nor the most intelligent, but the one most responsive to change".

*Charles Darwin*

"Strategy is a deliberate search for a plan of action that will develop a business's competitive advantage and compound it".

*Bruce D. Henderson*

"Awareness of the environment is not special project to be undertaken only when warning of change becomes deafening".

*Clifton Garvin, Kenneth R. Andrews*



## Definition of Business

The term 'typically' refers to the development and processing of economic values in society. Normally, the term is applied to portion of economic activities whose primary purpose is to provide goods and services for society in an effective manner. It is also applied to economics and commercial activities of institutions which having other purposes.

Business principally comprises of an all profit seeking activities of the organisation which provide goods and services that are necessary to economic system. It is the major economic pulse of a nation, striving to increase society's standard of living. Finally, profits are a primary mechanism for motivating these activities.

Business may be defined as "the organised effort by individuals to produce goods and services to sell these goods and services in a market place and to reap some reward for this effort."

Functionally, we may define business as "those human activities which involves production or purchase of goods with the object of selling them at a profit margin".

Business According to Prof. R. N. Owens

"Business is an enterprise engaged in the production and distribution of goods for sale in a market or rendering of services for a price".

Business According to L.R. Dicksee

"Business refers to a form of activity conducted with on objective of earning profits for the benefit of those on whose behalf the activity is conducted".

Business According to Urwick and Hunt

"Business is any enterprise which makes, distributes or provides any article or service which other members of the community need and are willing to pay for"

Business According to Lewis Henry

"Business may be defined as human activity directed towards producing or acquiring wealth through buying and selling of goods".

## Characteristics of Business

According to L.H. Haney, "Business may be defined as human activities directed towards providing or acquiring wealth through buying and selling goods". This definition includes activities relating to the production of goods. A vital omission is 'services'. Business includes rendering of services also. The main characteristics of business are;

- 1. Entrepreneur** – There must be someone to take initiate for establishing a business. The person who recognises the need for a product or service is known as entrepreneur. The entrepreneur is a key figure in the process of economic growth. The quality of entrepreneurship exiting in any region determines to a large growth. The quality of entrepreneurship existing in any region determines to a large extent the development of that region. The entrepreneur visualizes a business, combines various factors of production and puts them into a going concern.
- 2. Economic Activities** – A Business includes only economic activities. All those activities relating to the production and distribution of goods and services are called economic activities. These activities are under-taken with economic motive. Business is carried on with a profit motive. Any activity undertaken without economic consideration will not be a part business. So, business covers only economic activities.
- 3. Exchange of Goods and Services** – A business must involve exchange of goods and services. The goods to be exchanged my either be produced or procured from other sources. The exchange of goods and services is undertaken with profit motive. Production or purchasing of goods and services for personal consumption do not constitute business. The purchase of goods by a retailer

constitutes business while the purchase of goods by a consumer is not business. The purchase of goods should be to sell them again. The same principle is applicable to services. If a person cooks his food at home it is not business, but if the same person cook at a restaurant, it is business, because he exchange his services for money.

4. **Profit Motive** – The profit motive is an important element of business. Any activity undertaken without profit motive is not business. A businessman tries to earn more and more profits out of his business activities. The incentive for earning profits keeps a person in business and is also necessary for the continuity of the business. This does not mean that there will not be losses in business. The object of starting a business is to earn profit through there may be losses. The profit motive does not entitle a businessman to start exploiting the consumers. The responsibility of business towards society restricts a businessman from earning exorbitant profit. The business activity will flourish more when the business serves the society.
5. **Risk and Uncertainty** – The business involves larger element of risk and uncertainty. In fact a business tries to foresee any future uncertainties and plan his business activities accordingly. The factors on which business depends are never certain, so the business opportunities will also be uncertain. These may be shift in demand, strike by employees, floods, war, fall in prices, fluctuations in money market etc. If a businessman is able to foresee uncertainties and is able to bear them then he will successful, otherwise he may be forced out of business. The risk element in business keeps a person vigilant and he tries to ward off his risk by executing his policies properly.
6. **Continuity of Transactions** – In business, only those transactions are included which have regularity and continuity. An isolated transaction will not be called business, even if the person earns from that deal. A person builds a house for himself, but later on sells it on profit. We will not sell them, this will be called business. So the transactions should have continuity and regularity, otherwise they will not be a part of business.
7. **Creation of Utility** – The goods are provided to the consumers s per their linkings and requirements. Business crates various types of utilities ion goods so that consumers may use them. The utility may be form utility, place utility, time utility etc. When raw materials are converted into finished goods, it creates from utility. The goods are transported from the places of production to the ultimate consumers; it creates place utility. In the present industrial world, production is not done only for the present but it is undertaken for the future also. The process of storing goods when they are not required and supplying them at a time when they are needed is called creation of time utility. So the business creates many utilities in goods so that the consumers may use them according to their preferences and needs.
8. **Organisation** – Every enterprise need an organisation for its successful working. Various business activities are divided into departments, sections, and jobs. An organisation creates the framework for managerial performance and helps in coordinating various business activities. A proper organisation is helpful in the smooth running of the business and helps to achieve its objectives.
9. **Financing** – Business enterprises cannot move a step without finance. The finances are required for providing fixed and working capital. The availability of other factors of production also depends upon the availability of finances. After estimating its financial requirements, the businessman tries to find out the sources from which these requirements will be met. A proper capital structure is must for the success of the business.
10. **Consumer Satisfaction** – The utilities of business is to supply goods to the consumers. The foods are produced for the consumers. If the consumer is satisfied, then he will purchase the same thing again, otherwise he will for in for an alternative commodity. The business should try to satisfy the consumer so that the demand for his products is maintained. The existence and expansion of business depends upon the liking of the consumers for the products of that business. The businessman should try to produce goods according to the linkings and tastes of consumers. The commodities should be made available when they are needed. Business and consumers exist for each other.

**11. Satisfying Social Need** – The business should aim at serving the society at large. The business is a socio-economic institution. It must look to the public good. A great emphasis is laid, now-a-days, on the social aspect of business and social obligations of business. It is not only the public which needs business but business also needs public support. A business must serve public purpose.

### Characteristics Of Business Environment

Business environment characteristics indicates the major challenges, opportunities, threat and weakness of the business.

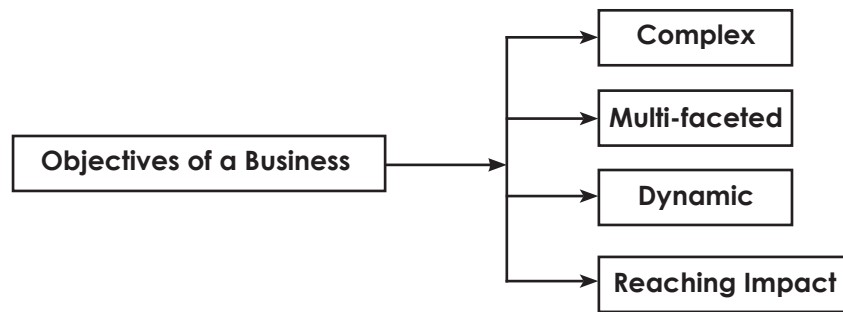

**Figure : The major characteristics of business environment**

#### Environment is complex

The environment is not made of any one simple constituent but consists of a number of factors, events, conditions and influences, arising from different sources.

It is difficult to guess the factors that constitute a given environment. Hence, environment is at the same time complex and somewhat easy to understand in parts, but difficult in totality.

#### Environment is dynamic

The environment does not remain constant but keeps on changing, For instance, the environment changes with the competitor's products and strategies, govt, policies, customers' preferences, etc.

Hence, in order to survive and grow, it becomes very important for every organization to understand its impact and adapt itself with such changes.

#### Environment is multi-faceted

Same element or influence of environment affects different firms in different ways.

This is frequently seen when the same development, say liberalization, is welcomed as an opportunity by one company while another company perceives it as a threat.

#### Environment has a far reaching impact

The environment has a long term and lasting impact on organisations. The growth and profitability of an organization depend critically on the environment in which it exists.

#### Environmental Influences On Business

The term Environmental analysis is defined as "the process by which strategists monitor the economic, governmental, legal, market, competitive, supplier, technological, geographic, social & cultural settings to determine opportunities and threats to their firms/company/organisation".

#### According to Barry M. Richman and Melvyn Copen

"Environment factors of constraints are largely if not totally external and beyond the control of individual industrial enterprises and their arrangements. These are essentially the 'givers' within which firms and their managements must operate in a specific country and they vary, often greatly from country to country."

According to Glueck and Jauch “ The environment includes outside the firm which can lead to opportunities for or threats to the firm. Although, there are many factors, the most important of the sectors are socio–economic, technical, supplier, competitors, and government.”

These definitions clearly reveal the following important factors:

- Strategist looks on the environment changes while to analyse the threats of the business alongwith searching and offering immense opportunities to business enterprises in the market.
- A successful business enterprise has to identify, appraise and respond to the new dimensions of various opportunities and threats in its internal and external environment.
- Successful business not only recognises business activities but also recognises the different elements in the environment.
- These factors are recognised and adopted to their business.
- It continuously monitor and adapt to the new environment.
- Environment analysis helps to survive and prosper the business activities.

Environment diagnosis principally consists of managerial decisions which made by strategist for analysing the significance of the data like strengths, weakness, opportunities and threats of the organisation in thin way to design their own strategy for formulation, implementation and controlling the internal environmental factors to firm.

Environmental analysis helps the strategic executive and manager in diagnosis of strategic competitive force and components of strategic management. However, internal environment of the organisation is quite essential and important from the point of view of the environment analysis. It is the cornerstone of the new and existing business opportunity analysis too.

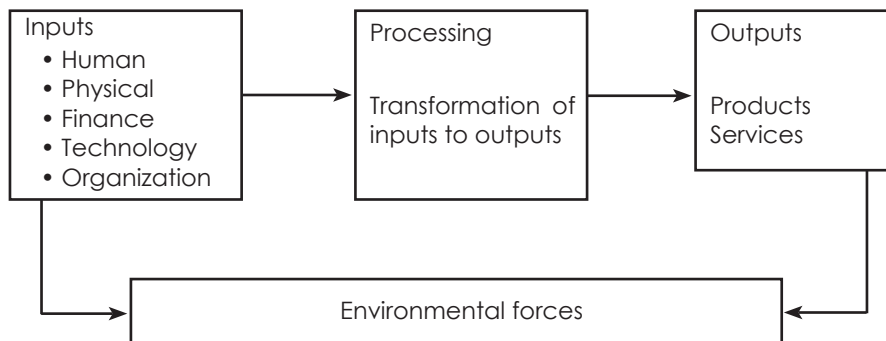

The above figure indicates the environmental forces on business. For instance, the individual life success depends on his innate capabilities like psychological factors, traits and skills. The survival is the basic element of success of the business organisation, it depends on its own strengths in terms of resources like money, men, machinery, materials, market and methods as its command. Organisation success depends on effective utilization of physical resource, financial resources and human resource like skills. These are adaptable to the business environment. Environment is the total of several external and internal forces that affects the functions of business.

Every business organisation principally consists of internal environment factors and set of external environmental factors. Environment factors influence business directly and indirectly.

Environment is the basic tool for all living human beings and all living creatures. Human environment consists of family, friends, peers, and neighbors except to natural environment. It additionally includes man–made structures like as buildings, furniture, roads and other physical infrastructure. These continuously interact with their business environment.

### **Problem in Understanding the Environment Influences:**

In strategic business environment, strategic managers face different problems in different circumstances in their business and have to understand the different environmental influence of business as outlined:

- The environment problems bring different dimensions to strategic managers. Strategic managers find it difficult to make decisions regarding different diversity of the business. Strategist will list all conceivable environment influences. These are emerging problems to strategist and influence to business.
- Uncertainty is the second problem encountered by strategic managers. Strategic managers typically claim to know the pace of the technological changes and the speed of the global network communication. There are more and more faster change now than ever before in business environment. Some of the changes are either predictable or unpredictable by the managers. Managers can try to understand future external influences on business enterprises and this task is very difficult to do.
- Strategic managers are not different from individuals in form; they are coping with complex and rigid situations. They tend to be simplifying complex and rigid problems which are focusing on aspects of the environment. These problems are historically important and confirm prior views of the business. Strategic managers are trying to take risk and simplify the complex and rigid problems in this way to breakout bias in the understanding of their environment. It will be still achieving a useful and usable level of analysis in business environment.

### **Framework to Understand the Environmental Influences**

While understanding the problems in business environment, strategic managers cannot ignore the real problems of the business. It will be an opportunity to identify a framework for understanding the business environment of the organisations. Environmental factors influence to identify key issues, find the ways for coping with complex and rigid issues and consider as challenging managerial thinking by managers.

- First stage is to know the initial structure and nature of the business organisations in terms of uncertainty. This is relatively either static or shows sign of change. Strategic managers should aware of the simple and complex problems and also know the decision skills to focus the rest of the analysis.
- Second stage is the auditing of the environmental that influence business. During this stage, strategic managers aim to identify different environmental influences which are likely to affect the organisation's development or performance. It is done through assessment of external environmental factors like political, economic, social and technological influences. These are factors bearing at the time of audit of the business. It helps to strategic managers to develop overall pictures or scenario of possible futures and extent to ascertain the change in the business.
- Strategic managers is to move to focus more towards an explicit consideration of the immediate environment of the organisations, it is the last stage of assessment of the strategic managers. It involves competitive environment and its five forces analysis of competitive environment and identify the key forces at work environment. It is also required to analyze the organisations' competitive position in form of resources and customers.

#### **1.3.3 Environmental Analysis**

An environmental analysis evaluates internal and external factors affecting an organization's performance, especially its marketing effort. Internal factors are referred to as the strengths and weaknesses of the organization. External factors are opportunities and threats presented by forces outside of the company. In general, this information is used by strategic planners in forecasting trends a year or more in advance. This method is distinct from surveillance, which focuses on a specific area or time.



A common synonym for environmental analysis is SWOT analysis, an acronym for strengths, weaknesses, opportunities, and threats. Another equivalent term is environmental scanning, referring to the ongoing nature of evaluating trends.

In this type of analysis, internal strengths may include a stable workforce, proprietary systems and methods, and other factors. Internal weaknesses may include labor-union problems, obsolete equipment, or aging facilities. External opportunities can include new-market creation, beneficial alliances, and positive trade agreements. External threats may be comprised in part of negative governmental regulations, international conflict, or natural disasters.

Using environmental analysis, strategic planners evaluate the operating environment and establish organizational goals. They determine whether or not the goals are obtainable with existing strategies. If they are not, new strategies must be developed or old ones must be adjusted. Several sources of information guide their strategic decisions.

A constant stream of pertinent information is necessary to perform an analysis. Online, printed, and TV business news sources report on external conditions that may impact operations and performance. Planners evaluate and use this data to determine the best course of action to avoid problems or to capitalize on opportunities. Metrics evaluating overall performance are another data stream used in strategic planning.

An organization's health and performance as a whole, rather than focusing on the performance of one part, is an important aspect. With a comprehensive overview of external forces, an organization is more able to respond to positive events as part of its growth strategy. Conversely, early threat identification allows organizational leadership to take timely action in developing a survival strategy.

Environmental analysis uses internal metrics in evaluating employee performance, customer satisfaction, maintenance costs, and similar factors. These metrics can be used to take early corrective action or to offer rewards to workers or customers. The outcomes of these measures should be monitored closely and adjusted as necessary.

There are more uses for this type of analysis than just fine-tuning performance. It is also central in identifying opportunities, such as new markets or the acquisition of new technology before its competitors. Its ongoing nature makes it a valuable tool for evaluating the financial potential of various strategies.

Environmental analysis for a business looks at the factors inherent in a business's environment that may have some impact thereof. This type of analysis is relatively qualitative and involves the identifying, scanning, analyzing and forecasting of the environmental variables. Some frameworks of environmental analysis have received large amounts of attention in the world of business management literature, such as SWOT analysis and PESTEL analysis.

To measure and/or improve the relative position of the business to the intrinsic environmental factors, one must first identify those factors that affect the business. This will need to be done at various internal levels, the company level, the regional level, the domestic level and the global level. While several frameworks exist as an aid to this step of identification (such as SWOT and PESTEL), they are merely tools that remind the identifier to consider certain types of factors. A good identification of environmental factors can be had as the result of a good brainstorming session with or without such frameworks. Those frameworks exist because of the ease of deployment and should be consulted, flexibly.

### **Scanning**

- This step in environmental analysis can be somewhat confusing. How does one scan for qualitative factors that have already been identified? Scanning, in the context of environmental analysis, refers to the process of distinguishing which of the identified factors have the most effect. Not all of the factors identified in the first step will carry the same weight, and the recognition of environmental factors most significant to the business will assist in rendering a course of improvement.

## Analyzing

- The next step in environmental analysis is to analyze the effect the relevant environmental variables have on different levels of the business, including the business at large. There are a plethora of tools available for this type of analysis, ranging from scenario building to benchmarking to the Delphi technique. Which every tool, or tools, chosen, the information will be collected and analyzed in similar fashions. Brainstorming, reviewing historical data and polling department heads and managers serves to collect information that will be used for statistical analysis; types of analysis include mean, mode, correlation and regression, among others. The methods of statistical analysis chosen will vary based upon what is being analyzed and the form held by the data itself. Some useful methods of analysis can be found in the techniques of company ratio analysis.

## Forecasting

- Once the environmental variables have been identified, deemed significant and analyzed, it becomes necessary to forecast the effect that said variables would have in the future. This is the primary function of the analysis of current and historical data. By looking at the trend each significant environmental variable is forecasted to take, a strategy report can be created, from which management can develop a business strategy in response thereto.

## SWOT Analysis

A SWOT Analysis looks at the strengths, weaknesses, opportunities and threats that are relevant to an organization in a new venture. A SWOT Analysis is a tool which allows users to look at the direction a company or organization may wish to move towards in the future. A SWOT Analysis is a useful tool, which in conjunction with others can help make informed decisions.

By specifying clear objectives and identifying internal and external factors that are either helpful or not, a short and simple SWOT analysis is a useful resource which may be incorporated into an organizations strategic planning model.

Strengths - Internal attributes that are helpful to the organization to achieving its objective

Weaknesses – Internal attributes that are harmful to the organization to achieving its objective

Opportunities – External factors that help the organization achieve its objective

Threats - External factors that are harmful to the organization to achieving its objective

After identifying the SWOT's, identification of the factors and their interdependence helps clarify the steps needed to achieve the ending objectives.

### Internal and External Factors

The aim of any SWOT analysis is to identify the key internal and external factors that are important to achieving the objective. SWOT analysis groups key pieces of information into two main categories:

- Internal factors – The strengths and weaknesses internal to the organization.
- External factors – The opportunities and threats presented by the external environment.

The internal factors may be viewed as strengths or weaknesses depending upon their impact on the organization's objectives. What may represent strengths with respect to one objective may be weaknesses for another objective. The factors may include all of the 4P's; as well as personnel, finance, manufacturing capabilities, and so on.

The external factors may include macroeconomic matters, technological change, legislation, and socio-cultural changes, as well as changes in the marketplace or competitive position. The results are often presented in the form of a matrix.

For any organization, the *environment* consists of the set of external conditions and forces that have the potential to influence the organization. In the case of Subway, for example, the environment contains

its customers, its rivals such as McDonald's and Kentucky Fried Chicken, social trends such as the shift in society toward healthier eating, political entities such as the US Congress, and many additional conditions and forces.

It is useful to break the concept of the environment down into two components. The *general environment (or macro environment)* includes overall trends and events in society such as social trends, technological trends, demographics, and economic conditions. The *industry (or competitive environment)* consists of multiple organizations that collectively compete with one another by providing similar goods, services, or both.

Every action that an organization takes, such as raising its prices or launching an advertising campaign, creates some degree of changes in the world around it. Most organizations are limited to influencing their industry. Subway's move to cut salt in its sandwiches, for example, may lead other fast-food firms to revisit the amount of salt contained in their products. A few organizations wield such power and influence that they can shape some elements of the general environment. While most organizations simply react to major technological trends, for example, the actions of firms such as Intel, Microsoft, and Apple help create these trends. Some aspects of the general environment, such as demographics, simply must be taken as a given by all organizations. Overall, the environment has a far greater influence on most organizations than most organizations have on the environment.

### **Why Does the Environment Matter?**

Understanding the environment that surrounds an organization is important to the executives in charge of the organizations. There are several reasons for this. First, the environment provides resources that an organization needs in order to create goods and services. In the seventeenth century, British poet John Donne famously noted that "no man is an island." Similarly, it is accurate to say that no organization is self-sufficient. As the human body must consume oxygen, food, and water, an organization needs to take in resources such as labor, money, and raw materials from outside its boundaries. Subway, for example, simply would cease to exist without the contributions of the franchisees that operate its stores, the suppliers that provide food and other necessary inputs, and the customers who provide Subway with money through purchasing its products. An organization cannot survive without the support of its environment.

Second, the environment is a source of opportunities and threats for an organization. *Opportunity* are events and trends that create chances to improve an organization's performance level. In the late 1990s, for example, Jared Fogle's growing fame created an opportunity for Subway to position itself as a healthy alternative to traditional fast-food restaurants. *Threat* are events and trends that may undermine an organization's performance. Subway faces a threat from some upstart restaurant chains. Saladworks, for example, offers a variety of salads that contain fewer than five hundred calories. Noodles and Company offers a variety of sandwiches, pasta dishes, and salads that contain fewer than four hundred calories. These two firms are much smaller than Subway, but they could grow to become substantial threats to Subway's positioning as a healthy eatery.

Executives must also realize that virtually any environmental trend or event is likely to create opportunities for some organizations and threats for others. This is true even in extreme cases. In addition to horrible human death and suffering, the March 2011 earthquake and tsunami in Japan devastated many organizations, ranging from small businesses that were simply wiped out to corporate giants such as Toyota whose manufacturing capabilities were undermined. As odd as it may seem, however, these tragic events also opened up significant opportunities for other organizations. The rebuilding of infrastructure and dwellings requires concrete, steel, and other materials. Japanese concrete manufacturers, steelmakers, and construction companies are likely to be very busy in the years ahead.

Third, the environment shapes the various strategic decisions that executives make as they attempt to lead their organizations to success. The environment often places important constraints on an organization's goals, for example, A firm that sets a goal of increasing annual sales by 50 percent might struggle to achieve this goal during an economic recession or if several new competitors enter

its business. Environmental conditions also need to be taken into account when examining whether to start doing business in a new country, whether to acquire another company, and whether to launch an innovative product, to name just a few.

The relationship between an organization and its environment may be discussed in terms of interactions between them in several areas, which are as follows:

### **1. Exchange of Information**

Organisations scan environmental information and use it for planning, decision making and control. Organisations transmit information to several internal and external agencies like govt., investors, trade unions and professional bodies.

### **2. Exchange of Resources**

Inputs to a business, like materials, men, money and machines, are drawn from environment. Output in the form of goods and services is supplied to the environment.

### **3. Exchange of Influence and Power**

- (i) Environment transmits opportunities and threats.
- (ii) Environment has a considerable stronghold over an organization by virtue of its command over inputs.
- (iii) Government controls the organization through legitimate power; markets, suppliers, etc., influence the planning and decision making of the organization.
- (iv) An organization also influences the environment through its command over internal resources and capacity to provide output.

### **Internal Analysis of the Organisation/Company**

Formulation of an effective and efficient strategy has based on a clear definition of organisation mission, an accurate assessment of the external environment and through internal analysis of the organisation. If organisation requires success it needs at least three ingredients. They are as listed:

- Strategy must be consistent with conditions in the competitive environment
- Strategy must place realistic requirements on the organisation/company's internal resources and capabilities.
- Strategy must be carefully formulated, implemented, controllable and executed. Internal analysis of the organisation is difficult and challenging one to strategist.

An internal analysis has lead to design a realistic organisation profile. It frequently involves tradeoff, value system judgments, educated and skilled guess as well as objective and standardized analysis. A systematic internal analysis leads to main objective of the organisation profile. It is essential to develop strategy and design a realistic mission for achievement of the strategy.

Internal analysis of the organisation must identify the strategic strengths, opportunities, weakness and threats that are based on organisation strategy. Organisational analysis identifies suitable strategy that based on the SWOT analysis.

Internal analysis can be achieved by first identifying key internal factors like value system, mission, objectives, management structure and nature, integrated power, relationship, human resource, company/organisation image and brand equity, physical assets, R&D, technological capabilities, marketing resource and financial resource factors and secondly by evaluating these factors.

### **The Value of Systematic Internal Assessment**

The value system of internal assessment is essential from the point of view of strategy formulation by the experienced strategist of the organisation/company. The value system applies to either large or

small business concern. It is critical in developing a successful business strategy. Regardless of the favorable opportunities in the environment, a strategy must consider the essential internal strengths, weaknesses, opportunities and threats of the organisation if such opportunities are to be maximized for accomplishment of goals.

The value of systematic internal analysis is particularly essential in small business organisations. Small business organisations are faced lot of problems like limited resource and markets. These organisations are flexible and capable to capture selected markets and effectively channel their limited resource and maximize these limited market opportunities. Internal analysis is the basis objectives of the organisation.

### **Steps/Process in the Development of a Organisational / Company Profile**

Company/organisation profile focus on determination of strengths and weakness of the strategic environment of the business. Identifying and evaluating strategic internal factors are based to accomplish organisation's future strategy. The major steps which are important to development of an organisation / company profile are listed below:

- Stage one Identification of Strategic Factors
- Stage two Using Value Chain Analysis
- Stage three Evaluations of strategic internal factors

### **Identification Of Strategic Factors**

An important identification of strategic factors approach as listed below:

1. Functional approach
2. The value chain approach

### **Functional Approach**

Functional approach refers to organisation basic capabilities; characteristics, swot analysis and limitation are the key strategic factors. Functional approach key strategic factors are as follows:

- Marketing
- Finance and accounting
- Production /operation/ technical
- Human resource development
- Organisation of general management

### **Marketing**

Marketing deals with the following issues:

- Organisation's products/service; product life cycle and marketing strategy.
- Concentration of sales in few products or little customer segmentation.
- Ability to be gathered information about the market.
- To know the market share or sub market share.
- Product/service mix and expansion potential: to know the life cycle of key products; to know the profit or loss of the product/service.
- To clearly know the channel of distribution; number, coverage, and control.
- To maintain effective sales organisation: to find out knowledge about the customer needs.
- To improve product/service quality with image and reputation of brand name.



- Efficient and effective utilization of available resource for effective sales promotion and advertising.
- To aware of the pricing strategy and pricing flexibility.
- To effective monitoring and feedback of the marketing functions and expansion of product.
- Effective implementation of after sales service and follow up.
- To keep standards, goodwill and brand loyalty.

### **Finance and Accounting**

Finance and accounting functions are as follows:

- Ability to raise short term and long-term capital: either debt or equity.
- To maintain good corporate level resource.
- To know the cost of capital relative to industry and competitors.
- Tax consideration.
- To build up effective relationship with owners, investors, financial institution and stock holders.
- To know the leverage position: capacity to utilize financial strategies, like lease or sale and lease back.
- To aware of the cost of entry and barriers of the entry.
- To know the price earning ratio.
- Present working capital position of the organisation.
- Effective cost control and ability to minimize cost of expenditure for production of goods and service.
- Financial size of the organisation.
- Efficient and effective accounting system for cost, budget, and profit planning of the organisation.

### **Production/Operation/Technical**

Production or operation or technical functions are as follows:

- To know the present raw material cost and availability.
- Inventory control system of the organisation.
- Location facilities; layout and utilization facilities.
- Technical efficiency and effective utilization of technical resource in the organisation.
- Effective use and implementation of subcontracting.
- Degree of vertical integration in terms of value added and profit margin of the product.
- To know the efficient and cost benefit of production techniques.
- Effective utilization and implementation of operation control procedure: design, scheduling, purchasing, quality control and efficiency.
- To know the costs and technological competencies relative to industry and competitors.
- Research development, innovative, advance technological development.
- Patents, trademarks and similar legal protection for their organisation products/ service.

### **Human Resource Development**

Human resource development functions are as outlined:

- Effective management of the human resource in the organisation.
- Improvement of employee skill and morale.
- Labor relations costs compared to industry and competition from present industry scenario.
- Efficient and effective formulation and implementation and controlling of the policies.
- Effective utilization of incentive to motivate employees' performance.
- To know the ability to level peaks and valleys of employment.
- To regulate employee turnover and absenteeism.
- Specialized skills and experience.

### **Organisation of General Management**

Organisation of general management functions are listed below:

- To know the organisation structure.
- Organisation image and prestige to public world.
- Organisation record for achieving goals and objectives.
- Effective utilization of resource and overall organisation control system.
- To effective monitoring organisation cultural climate.
- Effective utilization of systematic procedure and tools and techniques in decision-making.
- To know the top management skills, capabilities and interest.
- Effective implementation of strategic planning system.
- To keep and maintain intra organisation synergy (multibusiness)

Some of which would be the focus of internal analysis in most business organisation.

Organisation is not likely to consider all of the factors which are potential strengths or weakness. Strategist has develop or review the factors which are important for success of the organisation.

For the analysis of the organisation, firstly, a strategist has to analyze the past trends like sales, costs and profitability. These trends are the major importance in identification of the internal factors of the organisation. Further this identification should be based on a clear picture of the nature of the organisation's sales trends. An anatomy of past trends has broken down by product lines, channels of distribution of goods and service into different segmentation of key customers, geographical region and sales approach should be developed in detail. A similar anatomy of past trends should focus on costs and profitability. Strategist has to conduct detailed investigation of the organisation's performance history that helps to isolate internal factors influencing sales, costs and profitability or their interrelationships. The above factors are important in future strategy decisions.

Identification of strategic factors also requires an external focus of the organisation. Strategist isolates key internal factors through analysis of past and present performance like industry conditions/trends and comparisons with competitors. In addition, strategic internal factors are often selected for in depth evaluation due to organisations are contemplating expansion of products or markets, diversification. Strategist carefully scrutinizes the industry under consideration of current competitors. This is a key for identifying strategic factors, if an organisation is evaluating its capabilities more into unfamiliar markets.

## External Environment

The concept of external environment is important for every kind of business operation. External environment is an attempt to understand the outside forces of the organisational boundaries that are helping to shape the organisation. The external environment can provide both facilitating and inhibiting influences on organisational performance. Key dimension of the external environment principally consists of a micro environment and a macro environment.

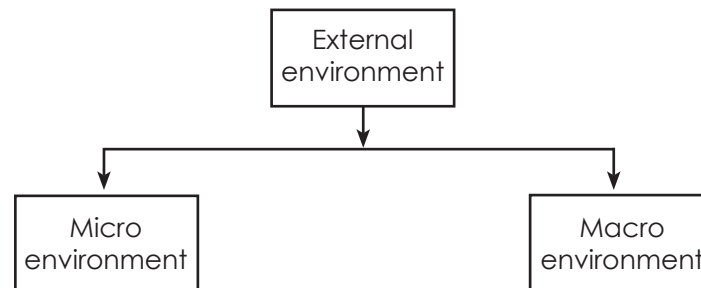

External environment of the business can be categorized into two broad categories as outlined

- Micro Environment
- Macro Environment

Micro environment of business enterprise refers to study on small area or immediate periphery of the business organisation. Micro environment directly or regularly influence business organisation. It analyses the following important factors:

- Human resource ( Employees) of the firm, their characteristics and how they are organized in the firm.
- It analyses the customer base of firm who are major and minor clients of business.
- It analyses the way of raising of finance of the firm.
- It analyses who are the suppliers of raw materials and how are the supply chain network between the supplier and firm being developed?
- It analyses the local communities of firm where its operating.
- It analyses the direct competition from the competitors and how they perform in business.

Macro environment study the overall issues of firms and broader dimensions. It principally consists of economic, technological, political, legal and socio-cultural factors. Macro environment issues are as outlined:

- It analyses that who are their competitors in the competitive world, how they operate and know what are threats from the competitors.
- It analyses which areas of technology become a threat to current product and services and find the reasons for threat.
- To analyses the bargaining power of suppliers and customers.
- It analyses nature of competition and how to face the threat and weakness of the firm.

## Environmental Scanning

Environmental scanning is also known as environmental monitoring. It is the process of gathering information regarding firm's/ organisation's or company, analyzing it and forecasting the impact of all predictable trends in environmental changes. Successful marketing always depends on its environmental scanning and its marketing programmes which depends on its environmental changes.



### Micro/Operating Environment

The micro / operating environment consists of the organisation or company's immediate environment that affects the performance of the organisation/company. These include as listed below:

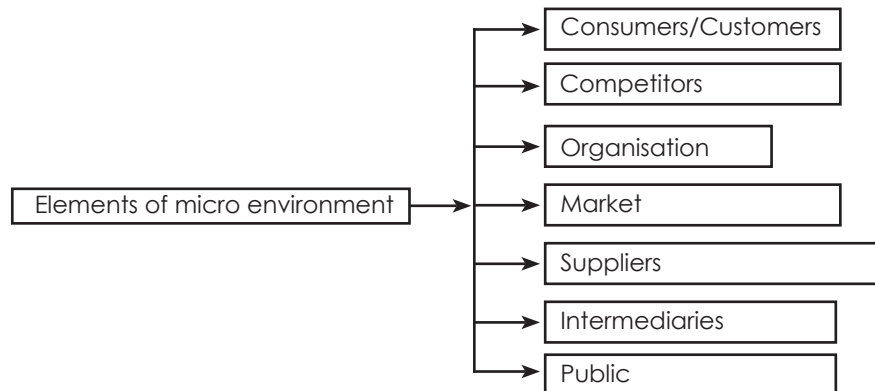

It is quite important that micro/operating environment factors are more intimately linked with organisation or company than macro/remote environment factors. The micro/ operating forces need not necessarily affect all organisations in a particular industry. Some of the micro factors particularly affect an organisation. For instance, an organisation that depends on a supplier may have a supplier environment that is quite entirely different from that of an organisation whose supply source is also different. When competing organisations in an industry have the same microelements, the relative success of the organisation depends on their relative effectiveness in dealing with these elements.

#### Suppliers

Supplier is the important force of the micro/operating environment of an organisation or company i.e., the supplier are those who supply the inputs like raw materials and components to the organisation. The reliable source / sources of supply for the smooth function of a business is very important. Uncertainties are generated due to the several supply problems like maintenance of inventory, delay of supply of inventory to organisation.

Many organisations give high importance to vendor development, vertical integration to solve the supply problem. Organisation depending on a single supplier is a risk factor due to a strike, lockout or any other production problem of the supplier. Always an organisation should depend on several supplier of the same raw material. Similarly, a change in attitude or behavior of the supplier may also affect the organisation. Hence, multiple sources of supply often help reduce such risks. The supply management assumes more importance in a scarcity environment.

#### Customers

The major task of business is to create and development of customers. A business can exist only because of its customers. Customers are the people who pay money to acquire or buy an organisations products in the form of goods and services. Monitoring the customer's behavior is a prerequisite for the business success. Consumer is the one who will ultimately use company's products and services.

Organisation may have different kinds of customers. They are listed below:

- Individual
- Households
- Industries
- Other commercial establishments
- Governments
- Other institutions



According to Peter Drucker the aim of business is to create and retain customer. For instance, the customers of an automobile parts manufacturing organisation may include individual automobile owners, automobile manufactures, public, private sector transport undertakings and other transport operators.

Organisation depending on a single customer is often much difficult and risky task. It may place the organisation in a poor bargaining position, apart from the risks of losing business result to winding up of business by the customer or due to the customers switching over to the competitors of the organisation.

The strategic choice of the customer segments should be made by considering a number of factors including the relative profitability, dependability, and stability of demand, growth prospects and the extent of competition.

Firms should know about who are their customers, expectations and buying patterns.

### **Competitors**

An organisations competitor includes not only the other organisation which market the same or similar products but also those who compete for the discretionary income of the customers. For instance, the competition for a organisation's televisions may not come from other televisions manufactures but also from two –wheeler, refrigerators, cooking ranges, stereo sets and so on and from organisations offering saving and investment scheme like banks, unit trust of India, companies accepting deposits or issuing shares or debenture etc. This competition among those products maybe described as desire competition as the primary task here is to influence the basic decision of the consumer. Such desires competition is generally very high in countries characterized by limited disposable incomes and many unsatisfied desires because of human wants are unlimited.

If the consumer decides to spread his discretionary income and recreation he will still be confronted with a number of alternatives to select from such as computer, stereo, two in one, three in one. The competition among such alternatives that satisfy a particular category of desire is called generic competition.

An implication of these demands a marketer should strive to create primary and selective demand for his products and services.

### **Marketing Intermediaries**

The immediate environment of a organisation may principally consist of a number of marketing intermediaries which are "organisations that aid the organisation in promoting, selling and distributing its goods to final buyers". In many cases, the customers are not aware of the manufacturer of the products and services they want to buy. They want to buy products and services from the local intermediaries. The marketing intermediaries are as outlined:

- Middlemen
- Agents
- Merchants
- Marketing agenesis
- Advertising agencies
- Marketing research firms
- Media
- Consulting firms

### **Publics**

Public is the one important marketing intermediaries for promoting, advertising, channeling, selling the organisation's product into different segmentation. If public accept the product of the organisation, definitely it will successful in the market, suppose product is rejected by the public definitely it will close the company.

## Organisation

An organization refers to a group of all individuals working in different capacities and the practices and culture they follow. In micro-environment analysis, nothing is as important as self-analysis, which is done by the organization itself.

Understanding one's own strengths and weaknesses in a particular business is of vital importance. Organisations consist of specific groups of people who are likely to influence an organization, which are as follows:

- (i) Owners-Proprietor, partners, shareholders, etc., who invest resources and also make major decisions for the business.
- (ii) Board of directors-Elected by share holders, the board is responsible for day-to-day and general management of the organization to ensure that it is being run in a way that best serves the shareholders' interests.
- (iii) Employees-People who actually do the work in an organization. Employees are the major force within an organization. It is important for an organization to have its employees embrace the same values and goals as the organization.

However, they differ in beliefs, education, attitudes, and capabilities. When the management and employees work towards different goals, everyone suffers.

## Market:

Market refers to the system of contact between an organization and its customers. The firm should study the trends and development and the key success factors of the market, which are as follows:

- The existing and the potential demand in market
- Market growth rate
- Cost structure
- Price sensitivity
- Technological structure
- Distribution system, etc

## Macro/ Remote Environment

Macro environment analysis is a review of all the factors that a company is unable to control. Companies conduct this analysis to stay abreast of the issue in the current business environment. A common tool for conducting a macro environment analysis is the PESTEL framework, which include factors from the political, economic, social, technological, environmental and legal aspects in the business environment. The ultimate purpose of this analysis is to create a strategy that will leverage as many of these external factors as possible to the company's favor.

**PESTLE analysis**, which is sometimes referred as **PEST analysis** is a concept in marketing principles. Moreover, this concept is used as a tool by companies the world over to track the environment they're operating in or are planning to launch a new project/product/service etc.

**PESTLE** is a mnemonic which in its expanded form denotes P for Political, E for Economic, S for Social, T for Technological, L for Legal and E for Environmental. It gives a bird's eye view of the whole environment from many different angles that one wants to check and keep a track of while contemplating on a certain idea/plan.

The framework has undergone certain alterations, as gurus of Marketing have added certain things like an E for Ethics to instill the element of demographics while utilizing the framework while researching the market.



There are certain questions that one needs to ask while conducting this **analysis**, which give them an idea of what things to keep in mind. They are:

- What is the political situation of the country and how can it affect the industry?
- What are the prevalent economic factors?
- How much importance does culture has in the market and what are its determinants?
- What technological innovations are likely to pop up and affect the market structure?
- Are there any current legislations that regulate the industry or can there be any change in the legislations for the industry?
- What are the environmental concerns for the industry?

All the aspects of this technique are crucial for any industry a business might be in. More than just understanding the market, this framework represents one of the vertebrae of the backbone of strategic management that not only defines what a company should do, but also accounts for an organization's goals and the strategies strung to them.

It may be so, that the importance of each of the factors may be different to different kinds of industries, but it is imperative to any strategy a company wants to develop that they conduct the **PESTLE analysis** as it forms a much more comprehensive version of the **SWOT analysis**.

It is very critical for one to understand the complete depth of each of the letters of the **PESTLE**. It is as below:

- 1. Political:** These factors determine the extent to which a government may influence the economy or a certain industry. [For example] a government may impose a new tax or duty due to which entire revenue generating structures of organizations might change. Political factors include tax policies, Fiscal policy, trade tariffs etc. that a government may levy around the fiscal year and it may affect the business environment (economic environment) to a great extent.
- 2. Economic:** These factors are determinants of an economy's performance that directly impacts a company and have resonating long term effects. [For example] a rise in the inflation rate of any economy would affect the way companies' price their products and services. Adding to that, it would affect the purchasing power of a consumer and change demand/supply models for that economy. Economic factors include inflation rate, interest rates, foreign exchange rates, economic growth patterns etc. It also accounts for the FDI (foreign direct investment) depending on certain specific industries who're undergoing this analysis.
- 3. Social:** These factors scrutinize the social environment of the market, and gauge determinants like cultural trends, demographics, population analytics etc. An example for this can be buying trends for Western countries like the US where there is high demand during the Holiday season.
- 4. Technological:** These factors pertain to innovations in technology that may affect the operations of the industry and the market favorably or unfavorably. This refers to automation, research and development and the amount of technological awareness that a market possesses.
- 5. Legal:** These factors have both external and internal sides. There are certain laws that affect the business environment in a certain country while there are certain policies that companies maintain for themselves. Legal analysis takes into account both of these angles and then charts out the strategies in light of these legislations. For example, consumer laws, safety standards, labor laws etc.
- 6. Environmental:** These factors include all those that influence or are determined by the surrounding environment. This aspect of the PESTLE is crucial for certain industries particularly for example tourism, farming, agriculture etc. Factors of a business environmental analysis include but are not limited to climate, weather, geographical location, global changes in climate, environmental offsets etc.

### **Demographic Environment**

Demography refers to study of the population. Demographic factors are as below:

- The population size
- Growth rate of population
- Age composition of the population
- Family size
- Economic stratification of the population
- Education levels
- Language
- Caste
- Religion
- Race
- Age
- Income
- Educational attainment
- Asset ownership
- Home ownership
- Employment status and location

These factors are the relevant to the business for formulating and implementing of strategy for controlling and accomplishment of the objectives of the organisation.

Demographic factors like size of the population, population growth, rate, age, composition, life expectancy, family size, spatial dispersal, occupational status, employment pattern etc., affect the demand for goods and service.

The growth of population and income result increases demand for goods and services. A rapidly increasing population indicates that a growing demand for many products. For instance, developing countries like India, Pakistan, etc; high population growth rate indicates an enormous increase in labor supply.

The occupational and spatial nobilities of population have implications for business. Labor is easily mobility between different occupations and regions. Its supply will be relatively smooth and this will affect the wage rate.

If a labor is highly heterogeneous in respect of language, caste and religion, ethnicity, etc., personal management is likely to become a more complex task. The heterogeneous population with its varied tastes, preferences, beliefs, temperaments, etc, gives rise to different demand patterns and calls for different marketing strategies.

Business organisation needs to study different demographic issues which are particularly address the following issues as listed below:

- What democratic trends will affect the market size of the different types of industry?
- What democratic trends will represent opportunities or threats?



## **Interested Domestic Environment Factors to Business**

We shall briefly discuss a few demographic factors which are interest of business:

- Population Size
- Geographic Distribution
- Ethnic Mix
- Income Distribution

### **Population Size**

Size of population is important either small or large to business organisation. Companies use population size for critical assessment for customer behavior and changes of the customer behavior and its impact on business. Important issues are outlined which are relating with population:

- It study the changes in a nation's birth rate and family size.
- It study the increase and decrease in the total population.
- It also study the changes effects in terms of rapid population growth on natural resources or food supplies.
- It also study the life expectancy of infants, youth and old age people.

These issues are very important to company for analysis of demand and supply of products and services. Healthcare companies role is needful for assessment of the product requirement for infants, youth, middle age and old age people.

### **Geographic Distribution**

It refers to geographic region and population that shifts from one region of a nation to another or from village/rural areas to urban areas. This is may be an impact on a company's strategic competitiveness in market. Geographic Distribution issues are outlined:

- Location advantage and government support is also very important to company.
- In the case, population is shifted from one region to another region. This is the significant impact on company's qualified workforce and company consider relocation of its skilled human resources.
- Today, working at home concept and electronically on the information highway have also begun in India in a very small level.

### **Ethnic Mix**

Ethnic mix is also important to company. Assessment and implications of ethnic mix is useful for company and its works force. Ethnic issues are outlined:

- Company should know the changes in the ethnic mix and its impact to company's product and services.
- Company should know the new products demand or existing products and services from the different ethnic groups.
- Company ready to face challenges, treats from ethnic and try to make solutions for these ethnic challenges and treats.

### **Income Distribution**

Income distribution is also one of the important factors of demographic environment. Company is planning to measure changes in incoming distribution, savings patterns for different level of individual. This purpose, company can forecast and assess the changes in income patterns and ready to identify new opportunities for companies.

### **Natural Environment**

Natural environment is the study of an important component of the nature. Natural environment includes geographical and ecological factors areas as below:

- Natural resource endowments,
- Weather
- Climate conditions
- Topographical factors
- Location aspects in the global context
- Port facilities are relevant to business.

Difference in geographical conditions between markets may sometimes call for changes in the marketing mix. Geographical and ecological factors also influence industries which help material index tend to be located near the raw material sources. Climate and weather conditions affect the location of certain industries like textile industry.

Ecological factors have recently assumed great importance. The depletion of natural resources, environmental pollution and the disturbance of the ecological balance has caused great concern. Government policies aimed at presentation of environmental purity and ecological balance, conservation of non-replevisable resources etc., have resulted in additional responsibilities and problems for business, and some of these have affect of increasing the cost of production and marketing, externalities also become an important problem of the business has to confront with.

All organizations exist and carry out their activities within the environment. The environment provides the organizations with inputs which they transform to outputs through internal processes and then the outputs are given back to the environment. Therefore in order to survive in the environment, organizations have to pay attention to the environment and match their activities to the environmental conditions.

Strategy is a firm's game plan for surviving in the changing environment. This implies that strategies are not static, they keep changing as the environment changes. For organizations to be effective and hence successful, they should respond appropriately to changes that occur in their respective environment. This is what is termed as strategic responses, which are the actions that an organization takes to align itself with the environment. Any firm that does not take actions to align itself with the environment cannot survive in the environment and is soon forced out of the market.

The strategic responses of an organization to its environment are as follows:

#### **Strategic Response:**

##### **(i) Least Resistance**

Least resistance is a type of response in which an organization simply follows the demands of the environment as it is, without any aggression or strategy formulation.

It just manages to survive by way of coping with its changing external environments. Such an organization is not ambitious and confident and is therefore called a goal-maintaining unit.

Some organisations are very passive in their behaviour and are solely guided by the signals of the external environment.

Such response is chosen because it is a simple path to maintaining basic goals.

##### **(ii) Proceed with Caution:**

It is a reactive type of response where organisations take intelligent steps to adapt with the changing external environment.

These organisations monitor the changes in that environment, analyze their impact on their own goals and activities and translate their assessment in terms of specific strategies for survival, stability and strength.

### **(iii) Dynamic Response:**

It is a proactive type of response where businesses regard the external environmental forces as partially manageable and controllable by their actions.

Not only do they recognize and ward off threats, they convert threats into opportunities.

They are highly confident of their strengths and conscious of their weaknesses.

### **Competitive Environment**

“Only firms who are able to continually build new strategic assets faster and cheaper than their competitors will earn superior returns over the long term”.

### **C.C. Markides and P.S. Williamson**

“Organisation succeed in a competitive market place over the long run because they can do certain things their customers value better than can their competitors”.



In business, being good is not good enough unless it comes from your customers and is supported by sales and market growth (sustainability). Factors in the macro environment and the competitive nature of business, means that your business and market position can easily be affected should you not predict the trends and movements within the economy, global community and your own industry and market segment. It is impossible for an organisation to develop strong competitive positioning strategies without a good understanding of the environment and its competitors and their strengths and weaknesses.

The competitive environment of a business is the part of a company's external environment that consists of other firms trying to win customers in the same market. It is the segment of the industry that includes all immediate rivals.

The founder of an enterprise should have the most comprehensive information possible on the line of business, its operating methods and future prospects, as well as on the regional competitive environment and market situation. All investments in charting such information enhance your company's possibilities of success.

Each new company will face competition, because its products or services respond to a customer need that can be satisfied through other options. In the same way as similar products, products that respond to the same need are competing goods or services.

In order to assess a company's potential to succeed in the market, the firm must be compared with its competitors. Through its business idea, the company must find a way to satisfy customers' needs better than competitors. The company must succeed in



- identifying its competitors
- evaluating the strengths, weaknesses and strategies of competitors
- finding a suitable competitive strategy with regard to competing companies.

For you, as an entrepreneur, it is important to know your competitors, their products and operating methods, in order to differentiate your company through its profile, offering or marketing.

### **Nature and Extent of Competition**

Nature and extent of competition is important to multinational companies and its customers. For better understanding, we shall know the following important questions that are relating to completion:

- (a) Who are the competitors in the market?
- (b) What are their product and services in the market?
- (c) What are their market share?
- (d) What are their financial positions?
- (e) What is the cost of products and services in the market?
- (f) Who are the potential competitors ?
- (g) What are the future products and services which are offered to customers? (h) What is the target market?

### **Co-operation in a Competitive Environment**

- Small number of only manufactures/sellers of a product may form association in this way achieve cooperation in a competitive environment.

### **Major purpose of Cooperation in a Competitive Environment**

- It is the association of manufacturer or sellers.
- It is coordination and unification of trade practices and the determination of the best means of safeguard their interest in the form of individually an collectively
- It helpful to decide the price of the products and service for example OPEC
- It may be form for deciding market share, prices and profits etc.
- It may be witnessed in highly competitive business environment.
- For example, various credit card and finance companies are entering agreements the other business to launch co-branded credit cards and debit cards. This type of arrangements help in reaching greater number of customers.

### **Co-operation on Account of Family Ownership**

- Cooperation is the primary tool for family owned business
- It generates automatically in business enterprise owned by a same family.
- Family is directly responsible for control, management and ownership of business.
- Family ownership group is nothing but a family and its kin and kith.
- Major and minor decisions made by the family ownership groups in business.
- It influence to managerial decisions and activities of the enterprise.
- It identify the goals and needs of the family and its business operations

- Family members amicably settle their business constraints like properties and ownership issues.

### Non Co-operation on Account of Family Ownership

- Quarrels with family members.
- Conflict among the family members.
- Family matters tend to distort their behavior in managing the business enterprise and also thereby damaging its functions.
- Succession problems.

### Five Force Model

Organisation offering products and services which are close substitute for each other. The task facing strategic managers is to analyze competitive force in an industry environment in order to identify the strengths, weakness, opportunities and threats confronting an organisation. Michael E.Porter, professor of the Harvard School of Business Administration has developed a framework, which is known as Five Forces Model. It helps to managers in their analysis of competitive force of the organisation. This model focuses on five forces which shape to create competition within an industry. Five forces are as below:

- The risk of new entry by potential competitors
- Risk of entry by potential customers
- The degree of rivalry among established companies within an industries
- The bargaining power of supplier
- The closeness of substitute to the industry's product

Porter argues that the stronger each of these forces, the more limited is the ability of established organisation to raise prices and earn greater profits. Within Porter's framework, a strong competitive force regards as a threat since it depresses profits. A weak competitive force views as an opportunity for an organisation to earn greater profits. Because of these forces beyond an organisation's direct control like industry evaluation, the strength of five forces may change through time. In such circumstances, the task facing strategic managers is to recognise opportunities and threats in order to develop and to formulate appropriate strategic opportunities.

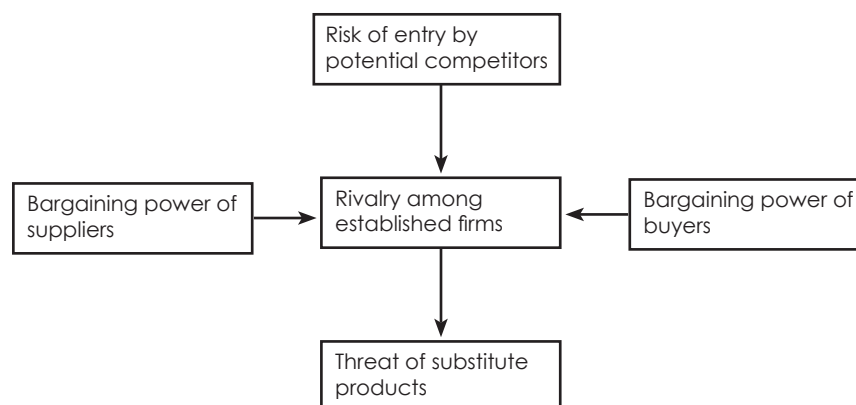

The character, mix and subtleties of competitive forces are never the same from one industry to another. Five force model is a powerful and widely used tool for systematically diagnosing the principles of competitive pressures in a market and it should be assessing the strength.

The five force model determine competitive scenario in different industry as outlined:

Identify the specific competitive pressures associated with each of the five forces

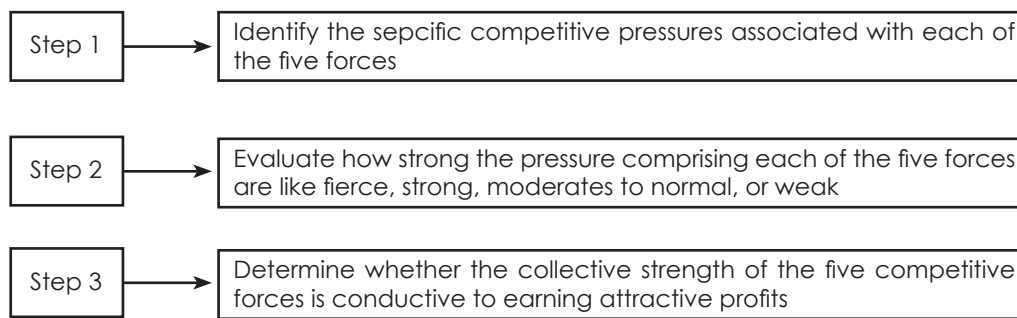

### Potential Competitors

Potential competitors are organisations which currently are not competing in an industry but they have the capability to do if they choose. Established organisations try to discourage potential competitors from entering to the industry. Since the more organisations enter an industry, it is very difficult for the established organisations to hold their share of the market and generate profits. Thus high risk of entry by potential competitors represents a threat to the profitability of the established organisations. On the other hand, if the risk of new entry is low, established organisations could take advantages of this opportunity to raise prices and earn greater returns.

Economist Joe Bain who identified three main sources of barriers to new entry:

- Brand loyalty
- Absolute cost advantage
- Economies of scale

### Brand Loyalty

Brand loyalty is buyer's priority for the products of established organisations. An organisation create brand loyalty through continuous advertising of brand and organisations names, patents protection of products, products innovation through organisation research and development programmes, an emphasis on high product quality and providing good after sales service. Significant brand loyalty makes it difficult for new entrants to take market share away from well established organisations. Thus it reduces the threat of entry by potential competitors.

### Absolute Cost Advantages

Absolute cost advantages can be achieved from superior production techniques. These techniques arises due to past experience, patents, hidden process; control of particular inputs required for production like labor, materials, equipment or management skills; These access to cheaper funds because exiting organisation represent low risks than established organisations. If established organisations have an absolute cost advantages, then again the threat of entry decreases.

### Economies of Scale

Economies of scale are the cost advantages associated with large organisation size. Sources of scale economies include cost reductions gained through mass producing a standardized out put, discount on bulk purchase of raw material inputs and components parts, the spreading of fixed costs over a large volume. A new entrant faces the dilemma of either entering on a small scale and its result suffering a significant cost advantages or taking a very large risk by entering on a large scale and bearing significant capital costs. A further risk of large-scale entry results to increase the supply of the product will reduce the prices.

### Rivalry Among Established Companies

It is the second of Porter's five competitive forces, it is the extent of rivalry among established organisation within the industry. When this competitive force is weak, business organisation have an opportunity to

raise prices to earn greater profits. But if it is strong, business organisation have an opportunity to reduce prices to earn fewer profits. It is significant due to price competition, including price wars, may result from the intense rivalry. Price competition limits reduce the profitability on sales. Thus intense rivalry among established organisations within industry is largely a function of three factors as listed below:

- Industry competitive structure
- Demand conditions
- The height of exist barriers in the industry

### **Competitive Structure**

Competitive structure refers to the numbers size, and distribution of products and service in the organisation in an industry. Different competitive structures have different implications for rivalry. Fragmented industries consist of a large number of small or medium sized organisations, none of which is in a position to dominate the industry. A consolidated industry dominates by small number of large organisation or, in extreme cases, a monopoly (by just one organisation). Fragmented industries included agriculture, video-rental, health clubs, real estate and pharmaceuticals etc.

Low entry barriers and commodity-type products are hard to differentiate characterize many fragmented industries. The combinations of these characteristics tend to result in boom and bust cycles of the industry. Low entry barrier indicates whenever demand is strong their impacts on profits are high. In this circumstance, there will be a flood of new entrants to cash in the boom.

In the case of consolidated industry, the competitive action of the organisation has directly affects the market share of its rivals, forcing to response from them. The result of the competitive interdependence can be dangerous to competitive spiral with rival companies. They are trying to undercut each other's prices of the products and service is pushing to industry and their profit down in this process. More typically, when price wars are threat, organisation competes on nonprime factors like product quality and design characteristics. This type of competition constitutes an attempt to build brand loyalty and minimize the likelihood of a price war.

### **Demand Conditions**

Industry demand conditions are another important determinant of the intensity of rivalry among the established organisations. Growing demand trends provides expansion and greater expansion of the production activity. When demand is growing ultimate result is a searching of entrants of customers or if existing customers are purchasing more of an industry products. When demand is growing, organisation can increases revenues without taking a market share away from other companies.

Therefore, declining demand result in more competition from rivalry organisation. It is very difficult to maintaining revenue and market share of the organisation. Consumers are leaving marketplace or when individual consumer buying less. Therefore, declines the demand, declining demand constitutes a major threat to organisation.

### **Exit Barriers**

When industry demand is declining because of exit barriers are serious competitive threat for organisation. Economic, strategic and emotional factors are treated as exit barriers. It keeps organisation competing in an industry even when returns are very low. Organisation can become locked into an unfavorable industry when exit barriers are high. Excess productive capacity tends to lead to intensified price competition, with companies cutting prices in an attempt to obtain the orders needed to utilize their idle capacity.

### **Exit barriers include the following**

- Investment in plant, machinery and equipment that have no alternative uses and cannot be sold off if the organisation wishes to leave the industry; it has to write-off the book value of the assets.
- High fixed cost of exists like severance pay to workers who are being made redundant.

- Emotional attachments to an industry, as when a company is unwilling to exit from its original industry for sentimental reasons.
- Strategic relationships between business units. For instance, within multi-industry organisation, a low return business unit may provide vital inputs for a high return business based in another industry. Thus the company may be unwilling to exit from the low return business.
- Economic dependence on the industry, as when company is not diversified and so relies on the industry for its income.

### **The Bargaining Power of Buyers**

It is third of Porter's five competitive forces; it is the bargaining power of buyer. Buyers can be influenced as competitive threat when they force down prices of the products and service. It means that when buyer demand is higher quality and better service which increasing operating costs of the products and service of the organisation.

According to Porter's buyers are more powerful in the following situations:

- The supply industry which consists of many small organisations and the buyers are few in number and large. These situations allow the buyers to dominate supply organisations.
- The buyer purchase in bulk in such situations, buyers can be bargained for price reductions of the products and service organisation.
- The supply industry depends on the buyers orders, buyers can bargained for price reductions of the products and service of the organisation.
- The buyer can switch orders between supply organisations at a low cost, thereby playing off organisations against each other to force down prices.
- It is economically feasible for the buyers to purchase the products and service from the several organisations at once.
- The buyer causes threat to supply their own needs through vertical integration, its impact on the price reducing of the products and service organisation.

### **The Bargaining Power of Suppliers**

The bargaining power of suppliers is the fourth of Porter's competitive force. Supplier influenced as a threat when they are capable to force up the price that organisation must pay for products and service or reduced the quality of goods supplied thereby, reducing the organisational profitability.

In other words, weak supplier gives opportunity to organisation to force down the prices and demand higher quality. As with the buyer, the capability of supplier to make demands on an organisation depends on power relative to organisation. According to Porter's suppliers are most powerful in the following cases:

- The suppliers product have no substitutes and is important to organisation.
- The suppliers does not depend on the organisation's industry, and supplier have little incentive to reduce prices or improve quality of the products and service.
- The suppliers of the respective products are differentiated which is more expensive for organisation to switch from one supplier to another. In such circumstance, the organisations depend on its supplier and cannot play them off against each other.
- To raise prices, suppliers can use threat of vertically integrating forward into the industry and competing directly with the organisation products and services.
- The buying organisation cannot use the threat of vertically integrating backward supplying their own needs as a means to reduce the product and service.

## The Threat of Substitute Products

The fifth and final force in the Porter's model is the threat of substitute products-the product of industries that serve identical consumer needs.

For instance, organisations in the coffee industry compete directly with those in the tea and soft drink industries. In the case of substitute products, if the price of the coffee rises too much relative to that of tea or soft drinks, than coffee drinkers will switch from coffee to those substitutes. The existence of close substitutes creates a strong competitive threat, limiting the price of an organisation.

## 1.4 COMPETITIVE INTELLIGENCE, COMMUNICATION OF STRATEGY, RESULT ANALYSIS

### Introduction

For a number of years, many firms have focused on the marketing principle of "knowing and satisfying customers at a profit." This focus has led these firms to consider new customer opportunities, modify channels of distribution, develop new products, and reorganize and restructure to achieve these objectives. In strong markets, such customer-focused actions can and did lead to growth and profitability. Today, these same firms realize that they cannot increase growth and profitability without a strong understanding of every aspect of their competitors' business and activities. Most companies have informally monitored their competitors for some time. They know something of their competitors' management, markets and customers, products and services, facilities, technologies and finances. However, fewer firms have applied their knowledge of their competitors in a proactive, disciplined, systematic fashion to achieve a competitive advantage. Instead, what competitor intelligence they have is often informal, scattered, anecdotal, and falls far short of its potential value. Although considerable data may exist on market shifts, customer needs, and competitors' capabilities and actions, few firms try hard enough to coordinate such information into competitive intelligence that they can act upon.

Competitive intelligence has undergone a raising interest in recent years as a result of the information explosion and the sharpness of information technologies. The general opinion of all business information professionals is that Competitive Intelligence deals with the collection, selection and interpretation of publicly-held information that emphasise competitors position, performance, capabilities and intentions. Competitive intelligence is the analytical process that transforms scattered information about competitors and customers into relevant, accurate and usable strategic knowledge on market evolution, business opportunities and threats.

Drawing up a communications strategy is an art, not a science and there are lots of different ways of approaching the task. Whether communications strategy is designed for a specific project or for the same period as organisational strategy, it should establish the objectives, audiences messages tools and activities resources timescales evaluation and amendment.

Strategic communication can mean either communicating a concept, a process, or data that satisfies a long term strategic goal of an organization by allowing facilitation of advanced planning, or communicating over long distances usually using international telecommunications or dedicated global network assets to coordinate actions and activities of operationally significant commercial, non-commercial and military business or combat and logistic subunits. It can also mean the related function within an organization, which handles internal and external communication processes. Strategic communication can also be used for political warfare.

In Public Relations and Communication Management, strong emphasis has been placed on the effectiveness of programmes, plans and campaigns, and with very good reason. At the end of the day, what matters most are the results achieved. So result analysis has been found with great importance in strategic performance management.

### 1.4.1 Competitive Intelligence (C.I.)

Business information gathered that improves organization's competitive ability, data gathered to improve an organization's competitive capacity. Competitive intelligence may include, for example, information about competitors' plans, activities, or products, and may sometimes be gained through **Industrial Espionage**. Such information can have a significant impact on a company's own plans: it could limit the effectiveness of a new product launch, or identify growing threats to important accounts, for example. Unless organizations monitor competitor activity and take appropriate action, their business faces risk.

A broad definition of **competitive intelligence** is the action of defining, gathering, analyzing, and distributing **intelligence** about products, customers, competitors and any aspect of the environment needed to support executives and managers in making strategic decisions for an organization.

#### Key points of this definition:

1. Competitive intelligence is an ethical and legal business practice, as opposed to **industrial espionage** which is illegal.
2. The focus is on the external business environment.
3. There is a process involved in gathering information, converting it into intelligence and then utilizing this in business decision making. Some CI professionals erroneously emphasize that if the intelligence gathered is not usable (or actionable) then it is not intelligence.

A more focused definition of CI regards it as the organizational function responsible for the early identification of risks and opportunities in the market before they become *obvious*. Experts also call this process the early signal analysis. This definition focuses attention on the difference between dissemination of widely available factual information (such as market statistics, financial reports, newspaper clippings) performed by functions such as libraries and information centers, and competitive intelligence which is a perspective on developments and events aimed at yielding a competitive edge.

The term CI is often viewed as synonymous with **competitor analysis**, but competitive intelligence is more than analyzing competitors — it is about making the organization more competitive relative to its entire environment and stakeholders: customers, competitors, distributors, technologies, macro-economic data etc.

#### The Importance of Competitive Intelligence

No organization can sit still and expect things to be the same month after month, year after year. At some point, something will happen to change your assumptions. And almost every decision (especially a strategic decision) is based on certain assumptions. Over time, these assumptions fall apart and if you fail to adjust with a continuous flow of new intelligence, then you will be forced to react in a way that makes it difficult to compete.

**John L. Colley Jr., Jacqueline L. Doyle and Robert D. Hardie** define Competitive Intelligence in their **Corporate Strategy**

"Competitive analysis is critical for managers formulating corporate or divisional strategies. Executives and planners must be aware of the levels and trends in performance of their competitors to determine the best direction for their divisions and parent corporations. They also must be capable of critically assessing their own organization's performance, over time, relative to its competitive peers."

Therefore, competitive intelligence can help test and validate your assumptions. Competitive intelligence also fills in gaps, covering areas that you failed to consider in your assumptions. And of course, competitive intelligence can yield some basic benefits:

- Source for best practices – the only real way to isolate and find "best practices" is to engage in some form of competitive intelligence; otherwise you end up relying on crude and generic type benchmarking data.



- Helps formulate strategy through an understanding of your industry, yourself, and your competitors. Competitive intelligence is the essence of strategic business analysis.
- Helps identify areas for improvement as well as risks and opportunities.
- Isolates performance gaps in relation to the competition.

In their book *Outsmarting the Competition*, authors John J. McGonagle, Jr. and Carolyn M. Vella provide these guidelines on when to use competitive intelligence:

- Competition increases from firms outside your industry's traditional boundaries.
- Consumers and customers become increasingly sophisticated and knowledgeable, demanding more and openly comparing products, services, and sources.
- Changes occur continuously in the nature and variety of the products and services you must offer to continue to compete.
- Significant changes occur in the ownership or senior management of firms in your industry, which may bring in new operating or marketing philosophies.

### **Objectives of Competitive Intelligence**

Organizations continually seek new ways to achieve sustainable competitive advantage and to counter aggressive competition. Proactive organizations recognize the advantage to be gained from an organized competitive intelligence program. In the Japanese semiconductor industry, for example, large organizations such as Mitsubishi, Mitsui, Sumitomo and Marubeni maintain intelligence departments that rival the U.S. Central Intelligence Agency in ability and accuracy. In the U.S., competitive intelligence programs are a popular tool among companies such as IBM Corp., Texas Instruments, Inc., Citi Corp, AT&T Inc., U.S. Sprint, McDonnell Douglas Corp., and 3M.

Organizations develop competitive intelligence programs with the following objectives in mind:

- i. To provide an early warning of opportunities and threats, such as new acquisitions or alliances and future competitive products and services;
- ii. To ensure greater management awareness of changes among competitors, making the organization better able to adapt and respond appropriately;
- iii. To ensure that the strategic planning decisions are based on relevant and timely competitive intelligence; and
- iv. To provide a systematic audit of the organization's competitiveness that gives the CEO an unfiltered and unbiased assessment of the firm's relative position.

### **The Role of the Management Accountant**

Competitive intelligence is a process of gathering data, creating information and making decisions. Management Accountants are trained to gather data, assimilate data into information and make decisions based upon information, frequently with their management counterparts.

Competitive intelligence may also be viewed as a competitiveness audit, a concept that Management Accountants are familiar with. Management Accountants' training and experience make them well-suited to the requirements of the competitive intelligence process.

Management Accountants may be actively involved in introducing a competitive intelligence process in several ways:

- identifying the need for a new or improved competitive intelligence process;
- educating top management and other senior managers about that need;
- developing a plan along with cross-functional team members for designing, developing and



implementing the new, improved competitive intelligence practice, including its underlying architectures;

- identifying the appropriate tools and techniques for conducting competitor analysis;
- providing financial input, analysis and expertise to the competitive intelligence effort;
- contributing to and using competitive intelligence in target costing;
- ensuring that the competitive intelligence efforts are tied to the firm's goals, strategies, objectives and internal processes, as appropriate; and,
- Continually assessing the new, improved competitive intelligence process and its implications for the organization and continually improving the process.

**The Competitive Intelligence Process**

An effective competitive intelligence process allows the appropriate members of a firm to actively and systematically collect, process, analyze, disseminate and assimilate competitor information so that they can respond appropriately. There are many approaches to creating competitive intelligence. Corporate experience suggests that several elements are critical to an effective intelligence process. These include:

- define the business issue(s);
- determine the sources of competitive data;
- gather and organize the data;
- produce actionable intelligence;
- communicate results and findings;
- provide input into the strategic planning process; and provide feedback and re-evaluate

It is explained in the following Diagram:

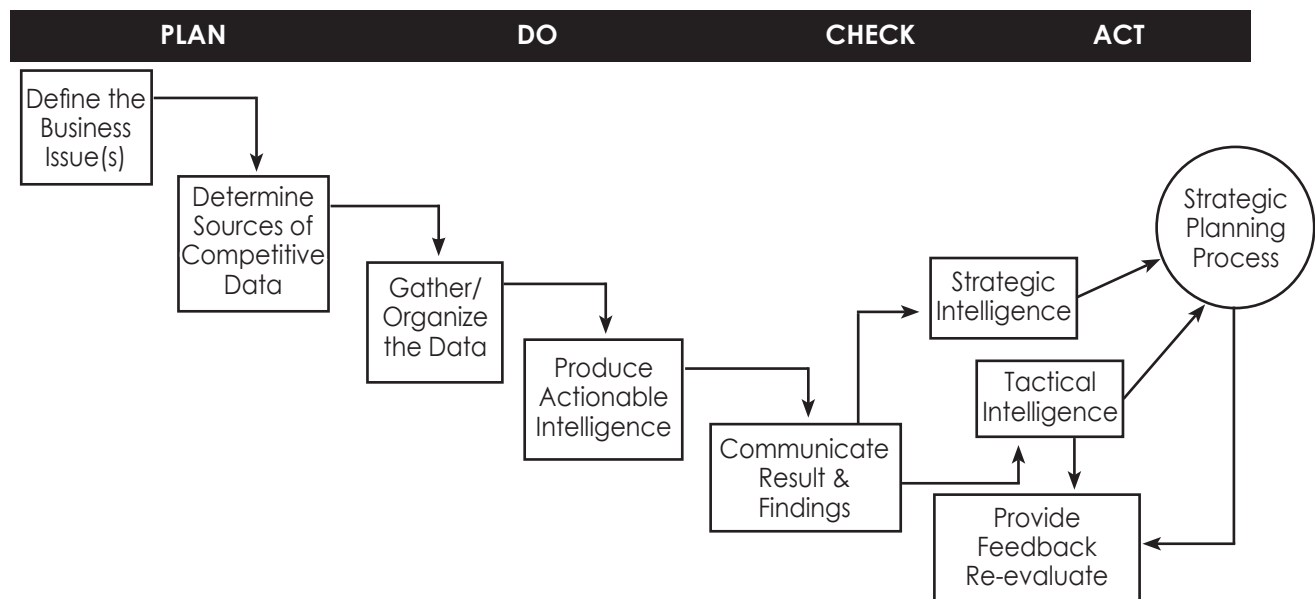

**Tools And Techniques for Developing Competitive Intelligence**

Just as competition has increased for most firms during the past 50 years, so there has been an evolution of thought, practice, and tools and techniques that support competitive intelligence efforts. These tools

and techniques can be categorized as strategic, product-oriented, customer-oriented, financial and behavioral.



### Aspects of competitive intelligence (Pictorial Representation)

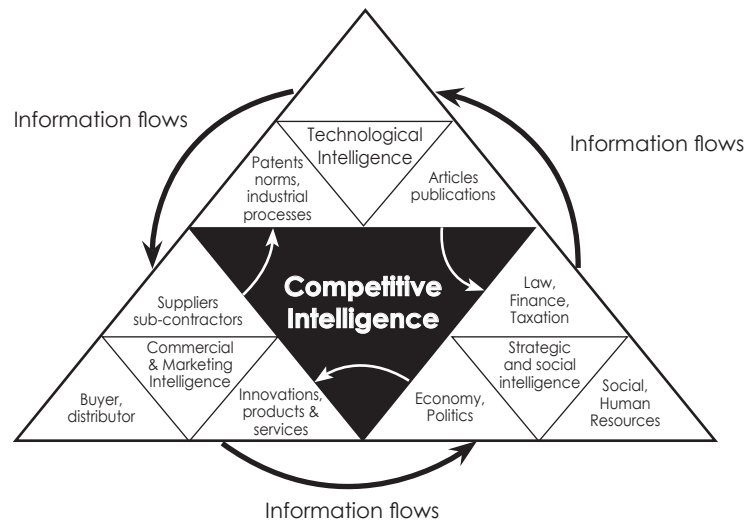

### Classification According To Information Types (Pictorial Representation)

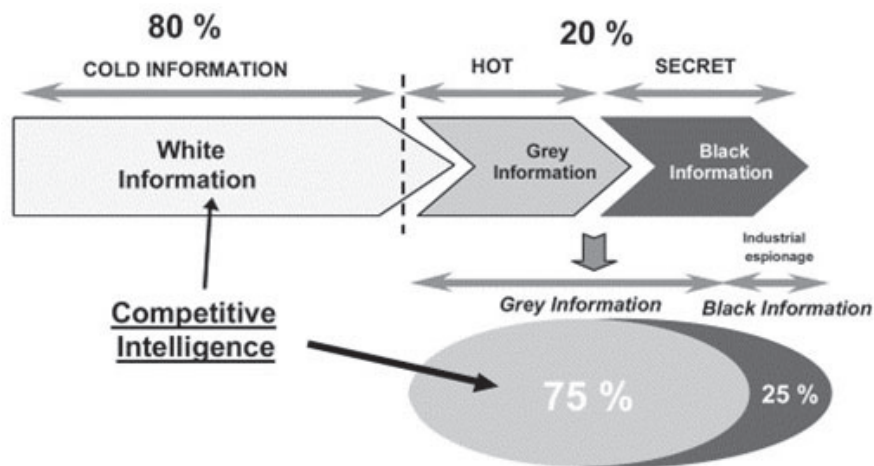

### Intelligence production process (Pictorial Representation)

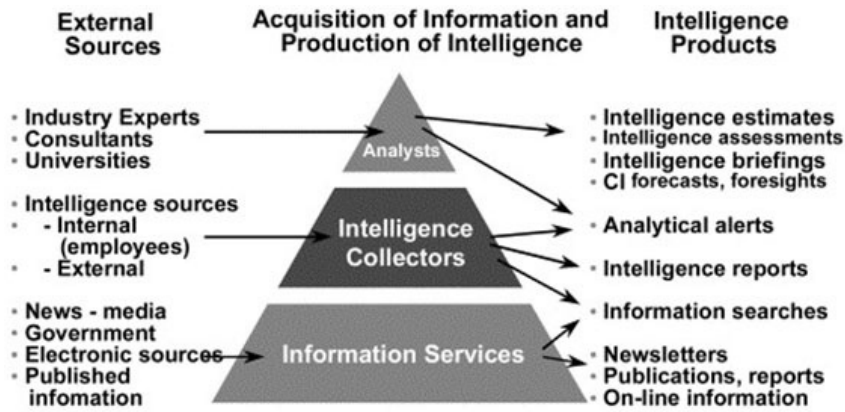

### Five Types of Intelligence Attitudes (Pictorial Representation)

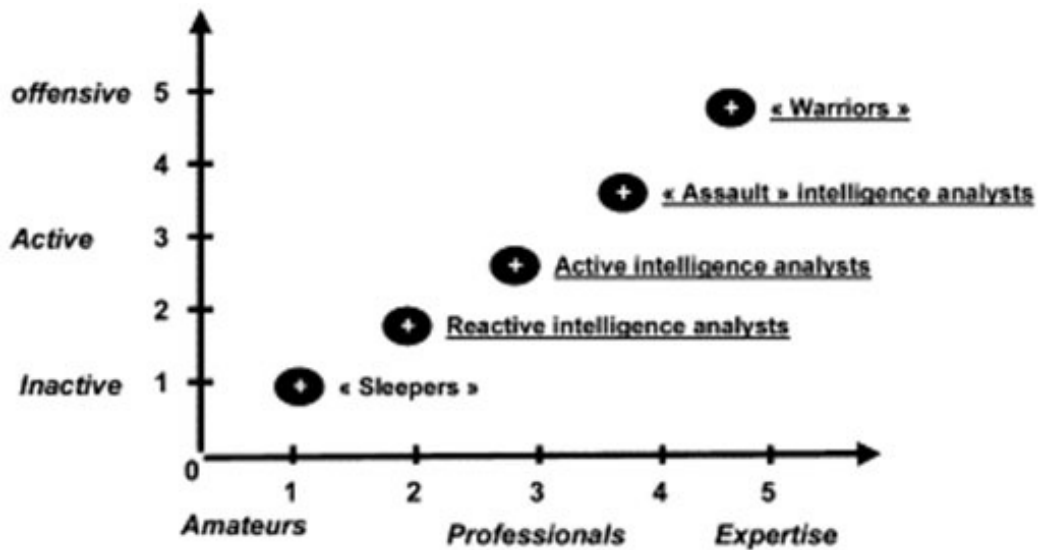

### Development of a successful competitive Intelligence Unit (Pictorial Representation)



### 1.4.2 Communication of Strategies

Communication strategies are plans for communicating information related to a specific issue, event, situation, or audience. They serve as the blueprints for communicating with the public, stakeholders, or even colleagues.

A communication strategy is “the selection of appropriate communication objectives and the identification of the specific brand awareness and brand attitude strategy”. This general strategy has to be linked to the roots of the organization and must be treated seriously. All of the employees and people involved in the organization must commit to the strategy 100%. There is no way that an organization can function well with the outside world if it does not have a sound plan for how to inform the public of what they do. A communication strategy can take on many different looks, ranging from a one-on-one interaction to a worldwide campaign.

**Scope of Communication of Strategies:** Communication of strategies should —

- outline the objective/goals of the communication,
- identify stakeholders,
- define key messages,
- pinpoint potential communication methods and vehicles for communicating information for a specific purpose, and
- specify the mechanisms that will be used to obtain feedback on the strategy.

Communication strategies do not have to be formal written documents. They can simply involve taking the time to think about a communication problem or issue and determining the best approach for communicating the message or information. Such an approach is especially true for simple issues that need to be conveyed about low-risk sites that have not generated a high level of public concern. However, at sites with high levels of public concern or site cleanup issues that are expected to be controversial, a more formal written strategy may be needed to ensure that all stakeholders are reached and all key messages are communicated effectively.

### Importance of a Communication of Strategies

Communication strategies are very prevalent, since all organizations have some sort of method to portray their core message to the community. Without having a strategy that effectively reaches the predetermined target audiences, there is no way that the organization will influence as many people. If

the organization is going to spend the time to figure out their key messages it would be best to develop a strong communication strategy. Furthermore, this would guarantee the time was not wasted and the message will reach the public sector in the easiest way.

When creating a communication strategy, there are two main elements an organization should consider: branding and the internet. Branding is an essential part of a communication strategy because it helps related your organization to an image or an idea.

Once the image or idea is recognizably related to the organization, someone who sees the brand will think of that organization. Internet also plays an important role in a communication strategy if the organization is targeting those born in the computer generation. Some nonprofit organizations only target the elderly or those who are low income. In these situations, the use of the web as a communications tool would be not as important. These are necessary considerations to make when determining which elements to include in your communication strategy.

### Process of Communication of Strategies

After careful research about communication strategies and their elements, a ten step communication strategy has been developed to assist nonprofit organizations.

1.	<b>Analysis of the Scenario</b>	It is important to understand what must be accomplished before starting the strategic plan.
2.	<b>Define the Goals of the Organization</b>	The overall goals of your organization must be defined before the planning stage begins. Without having a set of goals, it can be difficult to formulate a successful plan.
3.	<b>Define the Goals of the Individual Programs Within the Organization</b>	The program goals must be defined as well. This goes along with the overall goals, but they are more specific to individual programs.
4.	<b>Define the Specific Means of Communication for Each Program</b>	The communication may be unique for each program, so the means of communication must be appropriate for different programs.
5.	<b>Define the Target Audiences</b>	The specific groups of people that need to be communicated with must be defined. They must also be prioritized in a manner that portrays their importance. A way of doing this would be a 1-10 scale.
6.	<b>Develop the Key Messages to be Portrayed</b>	The important messages that the organization is striving to portray must be developed. This will allow the target audience to better understand the goals of the organization.
7.	<b>Propose a Timeline of Events</b>	An organized timeline of events must be created. This gives a strict guideline that will keep the organization on track and enforces that all tasks are executed in a timely manner.
8.	<b>Develop Initial Plan</b>	The creation of the initial plan generates a direction for the organization to proceed in. It is the step-by step process that will be followed.
9.	<b>Implement Elements of the Plan</b>	This is where elements of the initial plan are put into action.
10.	<b>Assess Elements of the Communication Strategy</b>	After the initial plan is implemented, it must be assessed to determine what is working and what must be adjusted.

**Table: Self developed Communication Strategy**

#### Step 1: Analysis of the Big Picture

The organization needs to figure what needs to get done, such as realizing the organization needs to create a communication strategy, to what extent and how quickly. If the organization has nothing that it currently does as a communication strategy then it needs to start from the beginning. If the



organization has a strategy that does not seem to work then it needs to realize that it needs to be improved and probably expanded upon what it already has.

### **Step 2: Define the Goals of the Organization**

A successful strategy can only be accomplished if the organization knows exactly what it wishes to achieve as a whole. If the goal of an organization is to reach out to the community and give the less fortunate a place to turn to, then your approach to your campaign will be different than if your goal was to make the community more green.

### **Step 3: Define the Goal of the Individual Programs within the Organization**

Every organization has different projects within it that will have goals that the project itself wants to accomplish outside of the actual organization's goals. These goals need to be determined and specifically defined so when the communication strategy is being developed, there is a consistent message being portrayed for the program. Once the breakdown of program goals comes into play, there is more chance for discrepancy for what that program's main goal is. Getting the utmost important goal decided upon makes decisions that will need to be made in the future easier.

### **Step 4: Define the Specific Means of Communication for each Program**

Similar to defining the goals of each individual program, defining the means of communication for each program needs to be decided before the initial plan is being created because it makes sure that everyone is going in the same direction with the programs.

### **Step 5: Define the Target Audience**

Determining an organization's target audience is an essential part of formulating a successful communication strategy. Without defining the proper market, it is nearly impossible to accurately devise a plan to widen an organization's reputation. After figuring out who your target audience is, the next step is to determine the importance of each audience. If the program targets many different groups and there is one group that is very knowledgeable and involved in the program and another group that is not knowledgeable or involved, then the group that does not know as much would be of higher importance. Looking at it from a different perspective, the rank of importance could be how much you need the audience as opposed to how much they know. If part of your audience is the people who fund your programs then, even if they know a great deal about the program, they still might be very high on the importance list because they need to be continuously reminded of who you are.

### **Step 6: Develop the Key Messages to be portrayed**

The development of the key messages allows the organization to inform the public about their previously determined goals. These messages help build awareness and allow for the organization to regulate how they are perceived.

### **Step 7: Propose a Timeline**

A timeline of events needs to be created to keep everyone on the same page about what and when steps in the strategy are being accomplished. A timeline can be as detailed as a step by step process of specific strategies that should be implemented and as broad as just saying how long you have to accomplish each one of these steps.

### **Step 8: Develop Initial Plan**

Strategic preparation of the initial plan is important in the process of creating a new communication strategy. If the organization is looking to expand public knowledge of its programs, they must determine what types of tools to use to get this message to their audiences. The organization must also consider their time, monetary, and personnel limitations when deciding what type of communication to use.

Public polling is a good way for an organization to learn about the current knowledge of their target audience and simultaneously inform those who do not know about them. If the organization chooses

to use public polling, they must choose appropriate locations to conduct the polling. Areas of high traffic containing the organization's target audiences are useful when conducting research through polls because they allow for many people to be polled in a shorter amount of time. The questions to be asked need to be determined prior to the polling and it is often helpful to create a spreadsheet with the questions to allow for easy recording of each respondents answers.

Another useful form of communication an organization should consider is a leaflet. Organizations should use leaflets when they want to inform their audiences about themselves in a simple, but yet descriptive way. Leaflets are inexpensive to create and are easily distributed to the target audience. For example, if an organization chooses to poll their target audiences, they can hand out a leaflet at the end of the questions. This allows for the organization to send the person off with information to take home. Leaflets also do not require a lot of updating, making them easy for an organization to maintain.

A third form of communication that is useful to many organizations is a newsletter. A newsletter allows for a lot of information to be distributed to the organization's target audience and is a low cost form of communication. On the newsletter, there should be a story about something that has occurred that was important to the organization. Stories like this help create interest in the target audience because they can gain a better understanding about the organization. It is also useful to include the organization's mission on the newsletter to be informative to the public. The newsletter should contain pictures of different happenings within the organization. This adds color and personality to the newsletter.

Holding a large event is a good way to bring a lot of people together under the name of the organization. The event does not necessarily have to be something directly related to the organization. One example of a large event is a concert where a local band plays. By advertising for the concert, the name of the organization will be introduced to the public. At the event the organization can have an information table so those who are interested in learning more about the organization hosting the event. The cost of this event would be higher than communicating through a newsletter, but the increase in public knowledge would also be much higher by hosting an event.

Finally, an organization should consider maintaining an up-to-date website. Internet plays an important role in communication so it is important for every organization to consider having one. The organization should consider their target audiences before spending the money to develop or maintain a website. For example, if the organization works with many older people, a website would not be as important to them as it would be for an organization aiming towards teenagers. Websites take time to maintain, so it may be necessary for an organization to hire outside help to complete this task. In this situation, the organization would have to determine how much money they can allot for the website maintenance.

### **Step 9: Implement Elements of the Plan**

After an organization has developed a list of ideas for their communication strategy, they must choose the best options for their organization and implement them. The implementation should follow the timeline created in step 7. For polling, the organization should determine an amount of time they will spend polling the public, and also the number of people they are looking to poll. To do this, they must consider the population of their target audience(s) and the amount of time the organization can spend conducting the polling. A sample size can be chosen using the following equation:

$$s = \frac{Z^2 \times (P) \times (1 - P)}{c^2}$$

Where s is the sample size, Z is a confidence level of 95% (1.96), P is the predicted percentage that the sample will pick a particular answer (0.5) and c is the confidence interval.

Once the sample size and time have been determined, the organization can begin polling. The results acquired through polling should be listed in a fashion that will be useful to the organization for analysis. For example, recording the answers in an Excel file to keep the answers together and organized.



The leaflets and newsletters can either be created within the organization or through an outside source. If they are created within the organization they will be less expensive, but it depends on whether or not the organization has enough personnel to assign the task to someone. Once they are created, the organization should begin distributing them during polling and events. The newsletters can be mailed to people within the organization's target audience.

The large event requires a lot of preparation. If an organization chooses to use this form of communication, they must determine what the event will be, how much it will cost, and how to advertise. Some useful forms of advertisement are posters, advertisements in newspapers, and invitations. Posters and invitations can be created within the organization, helping to keep the cost down. The organization needs to consider where to hold the event. Two possibilities are holding it outside or in a large hall. Holding it outside would most likely be less expensive, but the organization would need to consider weather conditions and space. Holding a large event would require close attention from the personnel to keep the details organized and have the event run smoothly.

Maintaining an updated website is an ongoing process that can be very useful to an organization. If the organization determines that their target audiences would benefit from a website, they should make sure it is maintained properly. If none of the personnel can maintain the website, the organization should determine how much money they can afford to allot to the website. Once this has been determined, the organization can begin looking for an outside source to maintain their website. A static website can be found as uninteresting to the public and will not benefit the organization. Therefore website maintenance is something that should be done regularly.

### **Step 10: Assess Elements of the Communication Strategy**

Assessment of the implemented communication strategy is the only way to make sure that the target audiences are being reached. In this stage the methods of communication should already be set and have been given enough time to influence the public. The way that the organization should assess the strategy is to first remember what it was trying to do in the first place, for example bringing in more people or how well the key message is understood by the public. Polling is a great way to get a feel for the public's views, since any question may be asked.

After all of this there is one detail that must not be skipped, a thorough evaluation must be done to make sure that there are no loose ends or skipped details. The more time that is spent finding out information about what the public knows the better you will be able to adapt your strategy later. So, assess, assess, assess.

Finally, after you have assessed every possible way that the strategy has gone; the organization should go back and check its core values and then proceed back to Step 8 to advance their strategy even more.

### **1.4.3 Result Analysis**

#### **What is a Result?**

A result is a describable or measurable change that is derived from a cause-and-effect relationship. Results are the same as outcomes, and are further qualified as immediate (short term), intermediate (medium term), or ultimate (long term).

#### **What is a Result Statement?**

A result statement outlines what a policy, program, or investment is **expected** to achieve or contribute to. It describes the change to a development activity in cooperation with others.

Outcomes = result statements



### Some Issues Relating to the Result Analysis

- Can the result be **measured**? Can the result be measured by either quantitative or qualitative performance indicators? Can performance indicators that will measure the result be easily found, collected, and analyzed?
- Is the result **realistic** and **achievable**? Is the result within the scope of the project's control or sphere of influence? Is there an adequate balance between the time, resources allocated and expected reach and depth of change expected? Are the results at the immediate and intermediate levels achievable within the funding levels and time period for the project? Is the result (immediate and intermediate outcome levels) achievable during the life cycle of the investment? In other words, can the expected changes (immediate and intermediate outcome levels) be realistically achieved by the end of the intervention?
- Is the result **relevant**? Does the result reflect country ownership and needs, and will it support higher-level developmental change in the strategies or programs it supports? Is the result aligned to the country partner's national development strategy? Does the result reflect needs and priorities among the beneficiaries that were identified in a participatory fashion? Does the result take into account the culture of the local population?

The management by objectives performance appraisal method has the supervisor and employee get together to set objectives in quantifiable terms. The appraisal method has worked to eliminate communication problems by the establishment of regular meetings, emphasizing results, and by being an ongoing process where new objectives have been established and old objectives had been modified as necessary in light of changed conditions. The purpose of performance appraisal has been fundamentally backward or historically oriented; past performance has been reviewed in the light of the results achieved.

Results indicate that aspects of rater-ratee relationship quality (i.e., supervisor satisfaction, supervisor support, supervisor trust) are strongly related to ratee reactions to performance appraisals. Rater-ratee relationship quality is more strongly related to appraisal reactions than appraisal participation or performance ratings. In total, these results highlight the importance of relationship quality to employee reactions to performance appraisal—and the importance of ratee reactions as an important resource in the social exchange between appraisal partners.

The general opinion of all business information professionals is that Competitive Intelligence deals with the collection, selection and interpretation of publicly-held information that emphasise competitors position, performance, capabilities and intentions. Competitive intelligence is the analytical process that transforms scattered information about competitors and customers into relevant, accurate and usable strategic knowledge on market evolution, business opportunities and threats.

Drawing up a communications strategy is an art, not a science and there are lots of different ways of approaching the task. Whether communications strategy is designed for a specific project or for the same period as organisational strategy, it should establish the objectives, audiences messages tools and activities resources timescales evaluation and amendment.

Strategic communication can mean either communicating a concept, a process, or data that satisfies a long term strategic goal of an organization by allowing facilitation of advanced planning, or communicating over long distances usually using international telecommunications or dedicated global network assets to coordinate actions and activities of operationally significant commercial, non-commercial and military business or combat and logistic subunits. It can also mean the related function within an organization, which handles internal and external communication processes. Strategic communication can also be used for political warfare.

In Public Relations and Communication Management, strong emphasis has been placed on the effectiveness of programmes, plans and campaigns, and with very good reason. At the end of the day,



what matters most are the results achieved. So result analysis has been found with great importance in strategic performance management.

## 1.5 FINANCIAL PERFORMANCE ANALYSIS

### Financial Performance

The word 'Performance' is derived from the word 'parfourmen', which means 'to do', 'to carry out' or 'to render'. It refers to the act of performing; execution, accomplishment, fulfillment, etc. In broader sense, performance refers to the accomplishment of a given task measured against preset standards of accuracy, completeness, cost, and speed. In other words, it refers to the degree to which an achievement is being or has been accomplished. In the words of Frich Kohlar "The performance is a general term applied to a part or to all the conducts of activities of an organization over a period of time often with reference to past or projected cost efficiency, management responsibility or accountability or the like. Thus, not just the presentation, but the quality of results achieved refers to the performance. Performance is used to indicate firm's success, conditions, and compliance.

Financial performance refers to the act of performing financial activity. In broader sense, financial performance refers to the degree to which financial objectives being or has been accomplished. It is the process of measuring the results of a firm's policies and operations in monetary terms. It is used to measure firm's overall financial health over a given period of time and can also be used to compare similar firms across the same industry or to compare industries or sectors in aggregation.

### Financial Performance Analysis

Financial performance analysis is the process of identifying the financial strengths and weaknesses of the firm by properly establishing the relationship between the items of balance sheet and profit and loss account. It also helps in short-term and long term forecasting and growth can be identified with the help of financial performance analysis. The dictionary meaning of 'analysis' is to resolve or separate a thing into its element or component parts for tracing their relation to the things as whole and to each other. The analysis of financial statement is a process of evaluating the relationship between the component parts of financial statement to obtain a better understanding of the firm's position and performance. This analysis can be undertaken by management of the firm or by parties outside the firm namely, owners, creditors, investors.

In short, the firm itself as well as various interested groups such as managers, shareholders, creditors, tax authorities, and others seek answers to the following important questions:

1. **What is the financial position of the firm at a given point of time?**
2. **How is the Financial Performance of the firm over a given period of time?**

These questions can be answered with the help of financial analysis of a firm. Financial analysis involves the use of financial statements. A financial statement is an organized collection of data according to logical and consistent accounting procedures. Its purpose is to convey an understanding of some financial aspects of a business firm. It may show a position at a moment of time as in the case of a Balance Sheet, or may reveal a series of activities over a given period of time, as in the case of an Income Statement. Thus, the term 'financial statements' generally refers to two basic statements: the Balance Sheet and the Income Statement.

The **Balance Sheet** shows the financial position (condition) of the firm at a given point of time. It provides a snapshot and may be regarded as a static picture.

"Balance sheet is a summary of a firm's financial position on a given date that shows Total assets = Total liabilities + Owner's equity."

The **Income Statement** (referred to in India as the profit and loss statement) reflects the performance of the firm over a period of time. "Income statement is a summary of a firm's revenues and expenses over a specified period, ending with net income or loss for the period."

However, financial statements do not reveal all the information related to the financial operations of a firm, but they furnish some extremely useful information, which highlights two important factors profitability and financial soundness. Thus analysis of financial statements is an important aid to financial performance analysis. Financial performance analysis includes analysis and interpretation of financial statements in such a way that it undertakes full diagnosis of the profitability and financial soundness of the business.

“The analysis of financial statements is a process of evaluating the relationship between component parts of financial statements to obtain a better understanding of the firm's position and performance.

The financial performance analysis identifies the financial strengths and weaknesses of the firm by properly establishing relationships between the items of the balance sheet and profit and loss account. The first task is to select the information relevant to the decision under consideration from the total information contained in the financial statements. The second is to arrange the information in a way to highlight significant relationships. The final is interpretation and drawing of inferences and conclusions. In short, “financial performance analysis is the process of selection, relation, and evaluation.”

### 1.5.1 Areas Of Financial Performance Analysis

Financial analysts often assess firm's production and productivity performance, profitability performance, liquidity performance, working capital performance, fixed assets performance, fund flow performance and social performance. Financial health is measured from the following perspectives:

1. Working capital Analysis
2. Financial structure Analysis
3. Activity Analysis
4. Profitability Analysis

### 1.5.2 Significance Of Financial Performance Analysis

Interest of various related groups is affected by the financial performance of a firm. Therefore, these groups analyze the financial performance of the firm. The type of analysis varies according to the specific interest of the party involved.

**Trade creditors:** interested in the liquidity of the firm (appraisal of firm's liquidity)

**Bond holders:** interested in the cash-flow ability of the firm (appraisal of firm's capital structure, the major sources and uses of funds, profitability over time, and projection of future profitability)

**Investors:** interested in present and expected future earnings as well as stability of these earnings (appraisal of firm's profitability and financial condition)

**Management:** interested in internal control, better financial condition and better performance (appraisal of firm's present financial condition, evaluation of opportunities in relation to this current position, return on investment provided by various assets of the company, etc).

### 1.5.3 Types Of Financial Performance Analysis

Financial performance analysis can be classified into different categories on the basis of material used and modes operandi as under:

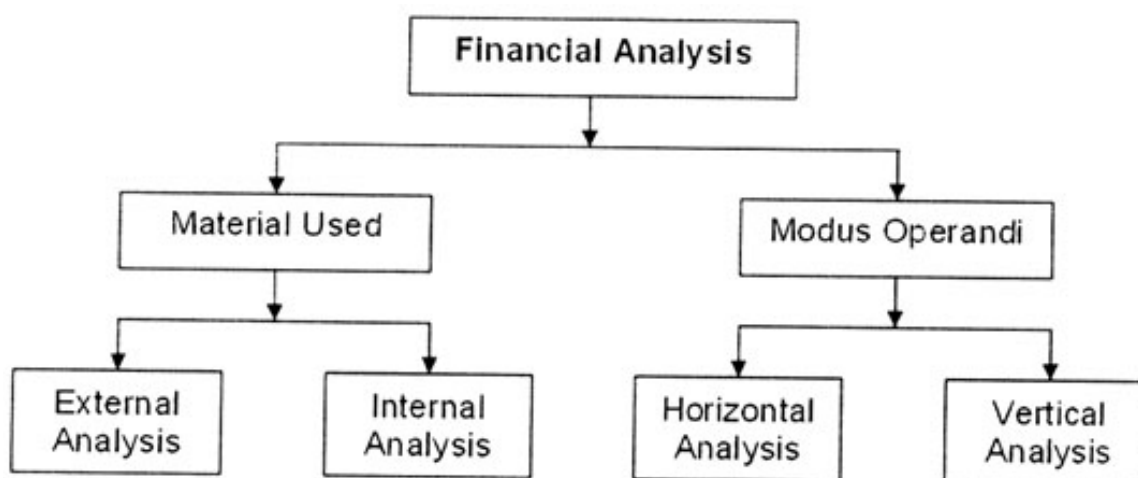

**A. Material used:** On the basis of material used financial performance can be analyzed in following two ways:

**1. External analysis**

This analysis is undertaken by the outsiders of the business namely investors, credit agencies, government agencies, and other creditors who have no access to the internal records of the company. They mainly use published financial statements for the analysis and as it serves limited purposes.

**2. Internal analysis**

This analysis is undertaken by the persons namely executives and employees of the organization or by the officers appointed by government or court who have access to the books of account and other information related to the business.

**B. Modus operandi:** On the basis of modus operandi financial performance can be analyze in the following two ways:

**1. Horizontal Analysis**

In this type of analysis financial statements for a number of years are reviewed and analyzed. The current year's figures are compared with the standard or base year and changes are shown usually in the form of percentage. This analysis helps the management to have an insight into levels and areas of strength and weaknesses. This analysis is also called Dynamic Analysis as it based on data from various years.

**2. Vertical Analysis**

In this type of Analysis study is made of quantitative relationship of the various items of financial statements on a particular date. This analysis is useful in comparing the performance of several companies in the same group, or divisions or departments in the same company. This analysis is not much helpful in proper analysis of firm's financial position because it depends on the data for one period. This analysis is also called Static Analysis as it based on data from one date or for one accounting period.

**1.5.4 Techniques/Tools Of Financial Performance Analysis**

An analysis of financial performance can be possible through the use of one or more tools / techniques of financial analysis:

## A. ACCOUNTING TECHNIQUES

It is also known as financial techniques. Various accounting techniques such as Comparative Financial Analysis, Common-size Financial Analysis, Trend Analysis, Fund Flow Analysis, Cash Flow Analysis, CVP Analysis, Ratio Analysis, Value Added Analysis etc. may be used for the purpose of financial analysis. Some of the important techniques which are suitable for the financial analysis are discussed hereunder:

### 1. Ratio Analysis

In order to evaluate financial condition and performance of a firm, the financial analyst needs certain tools to be applied on various financial aspects. One of the widely used and powerful tools is ratio or index. Ratios express the numerical relationship between two or more things. This relationship can be expressed as percentages (25% of revenue), fraction (one-fourth of revenue), or proportion of numbers (1:4). Accounting ratios are used to describe significant relationships, which exist between figures shown on a balance sheet, in a profit and loss account, in a budgetary control system or in any other part of the accounting organization. Ratio analysis plays an important role in determining the financial strengths and weaknesses of a company relative to that of other companies in the same industry. The analysis also reveals whether the company's financial position has been improving or deteriorating over time. Ratios can be classified into four broad groups on the basis of items used: (i) Liquidity Ratio, (ii) Capital Structure/Leverage Ratios, (iii) Profitability Ratios, and (iv) Activity Ratios.

### 2. Common-Size Financial Analysis

Common-size statement is also known as component percentage statement or vertical statement. In this technique net revenue, total assets or total liabilities is taken as 100 per cent and the percentage of individual items are calculated like wise. It highlights the relative change in each group of expenses, assets and liabilities.

#### Common Size Financial Statements

Common size ratios are used to compare financial statements of different-size companies or of the same company over different periods. By expressing the items in proportion to some size-related measure, standardized financial statements can be created, revealing trends and providing insight into how the different companies compare.

The common size ratio for each line on the financial statement is calculated as follows:

Common Size Ratio =  $\frac{\text{Item of Interest}}{\text{Reference Item}}$

For example, if the item of interest is inventory and it is referenced to total assets (as it normally would be), the common size ratio would be:

Common Size Ratio for Inventory =  $\frac{\text{Inventory}}{\text{Total Assets}}$

The ratios often are expressed as percentages of the reference amount. Common size statements usually are prepared for the income statement and balance sheet, expressing information as follows:

- Income statement items - expressed as a percentage of total revenue.
- Balance sheet items - expressed as a percentage of total assets



The following example income statement shows both the rupee amounts and the common size ratios

	<b>Income Statement</b>	<b>Common Size Income Statement</b>
<b>Revenue</b>	<b>70,134</b>	<b>100%</b>
Cost of Goods Sold	44,221	63.1%
Gross Profit	25,913	36.9%
SG&A Expense	13,531	19.3%
Operating Income	12,382	17.7%
Interest Expense	2,862	4.1%
Provision for Taxes	3,766	5.4%
Net Income	5,754	8.2%

For the balance sheet, the common size percentages are referenced to the total assets. The following sample balance sheet shows both the rupee amounts and the common size ratios:

<b>Common Size Balance Sheet</b>		
	<b>Balance Sheet</b>	<b>Common-Size Balance Sheet</b>
<b>ASSETS</b>		
Cash & Marketable Securities	6,029	15.1%
Accounts Receivable	14,378	36.0%
Inventory	17,136	42.9%
Total Current Assets	37,543	93.9%
Property, Plant, & Equipment	2,442	6.1%
Total Assets	39,985	100%
<b>LIABILITIES AND SHAREHOLDERS' EQUITY</b>		
Current Liabilities	14,251	35.6%
Long-Term Debt	12,624	31.6%
Total Liabilities	26,875	67.2%
Shareholders' Equity	13,110	32.8%
Total Liabilities & Equity	39,985	100%

The above common size statements are prepared in a vertical analysis, referencing each line on the financial statement to a total value on the statement in a given period.

The ratios in common size statements tend to have less variation than the absolute values themselves, and trends in the ratios can reveal important changes in the business. Historical comparisons can be made in a time-series analysis to identify such trends.

Common size statements also can be used to compare the firm to other firms.

### **Comparisons Between Companies (Cross-Sectional Analysis)**

Common size financial statements can be used to compare multiple companies at the same point in time. A common-size analysis is especially useful when comparing companies of different sizes. It often is insightful to compare a firm to the best performing firm in its industry (benchmarking). A firm also can

be compared to its industry as a whole. To compare to the industry, the ratios are calculated for each firm in the industry and an average for the industry is calculated. Comparative statements then may be constructed with the company of interest in one column and the industry averages in another. The result is a quick overview of where the firm stands in the industry with respect to key items on the financial statements.

### **Limitation**

As with financial statements in general, the interpretation of common size statements is subject to many of the limitations in the accounting data used to construct them. For example:

- Different accounting policies may be used by different firms or within the same firm at different points in time. Adjustments should be made for such differences.
- Different firms may use different accounting calendars, so the accounting periods may not be directly comparable.

### **3. Trend Analysis**

Trend analysis indicates changes in an item or a group of items over a period of time and helps to draw the conclusion regarding the changes in data. In this technique, a base year is chosen and the amount of item for that year is taken as one hundred for that year. On the basis of that the index numbers for other years are calculated. It shows the direction in which concern is going.

#### **B. Statistical Techniques**

Every analysis does involve the use of various statistical techniques. Some of the important statistical techniques which are suitable for the financial analysis are discussed herein:

##### **1. Measures of Central Tendency**

Measures of central tendency are also known as statistical averages. It is the single value which represents the whole series and is contain its measure characteristics. The main objective is to give a brief picture of a large group, which it represents, and to give a basis of comparison with other groups.

Arithmetic mean, median, mode, geometric mean and harmonic mean are the main measures of tendency. Mean, also known as arithmetic average, is the most common measure of central tendency. It is defined as the value which obtained by dividing the total of the values of various given items in a series by the total number of items. It can be figured as:

$$\text{Mean (X)} = \frac{x_1 + x_2 + \dots + x_n}{n}$$

##### **2. Measures of Dispersion**

Average is the central value which represents the entire series but it fails to give any idea about the scatter of the values of items of a series around the true value of average. In order to measure this scatter, measures of dispersion are calculated. Measures of dispersion, indicates the extent, to which the individual values fall away from the average or the central value. Range, mean deviation and standard deviation are the important measures of dispersion.

These measures can be stated in two ways. One method of statements shows the absolute amount of deviation, while the other presents the relative amount of deviation. For purpose of comparison, the absolute amount of a measurement is not always as valuable as an expression of the relative amount. The measures of dispersion, which are expressed in terms of the original units of a series, are termed as 'absolute measure'. Relative measures of dispersion are obtained as ratios or percentages known as 'coefficient' which are pure numbers independent of measurement. "Percentages of variation are known as co-efficient of dispersion or co-efficient of variation. They state the degree of variation." Therefore, for the purpose of comparison of variability the relative measures of dispersion should be computed.

### 3. Correlation and Regression Analysis

Correlation is a statistical technique which measures degree and direction of relationship between the variables. It always lies between  $\pm 1$ . It is a relative measure. While regression measures the nature and extent of average relationship in terms of the original units of the data. If one of the regression coefficients is greater than unit the other must be less than unit. It is an absolute measure of relationship.

Correlation analysis is a method of determining whether two sets of data are related in a manner such that they increase together, if one increases, the other decreases. Regression analysis, on the other hand, hypothesizes a particular direction of the relationship. With regression one variable is determined by the others.

### 4. Analysis of Time Series

The time series refers to the arrangement of statistical data in accordance with the time of its occurrence. It is dynamic distribution which reveals a good deal of variations over time. Various types of sources are at work to influence dynamic changes in a time series. It aims to find the pattern of change in statistical data over the regular interval of time and to arrive at an estimate with this pattern for business decision making.

The four component elements which bring variations in time series can be classified as secular variation (trend), cyclical variation (regular), seasonal variation (regular) and erratic variation (irregular). The combined impact, either additive or multiplicative, of these components brings changes in statistical data. Thus original data can be represented as:

$$Y = T + S + C + I \text{ (Additive Model) \& } y = T \times S \times C \times I \text{ (Multiplicative Model)}$$

Where, Y = Original Data,

T = Trend Value,

S = Seasonal Component,

C = Cyclical Component,

I = Erratic Component.

The analysis of time series intend to isolate and measure the separate effect of these components as they appears in a given series over a period of time.

### 5. Index Number

According Lawrence J. Kaplan an index number is a statistical measure of fluctuations in a variable arranged in the form of a series and using a base for making comparison. The index number is used to represent diverse changes in a group of related variables. It represents changes in terms of rates, ratios or percentages called 'relatives' such as 'price relatives' (measures relative changes in prices), 'quantity relatives' (measures relative changes in quantity) etc. Since it represents an average of relative changes in a group of related variables relevant to a given phenomenon they are often described as 'barometers of economic change'.

### 6. t-test

t-test applies only in case of small samples when population variance is unknown. It is based on t-distribution and is considered appropriate test for judging the significance of difference between the means of two samples in case of small sample(s) when population variance is not known. In case of two samples pared t-test is used for judging the significance of the mean of difference between the two related samples. it can also be used for judging the significance of the coefficients of simple and partial correlations.

The relevant test statistic, t, is calculated from the sample data and then compared with its probable value based on t-distribution (from the table) at a specific level of significance for concerning degrees



of freedom for accepting or rejecting the null hypothesis

$$t = \frac{X - \mu_{H_0}}{\sigma_s / \sqrt{n}} \quad \text{Reject : } t > \text{Table value and Accept : } t \leq \text{Table value}$$

### 7. Chi-Square ( $X^2$ ) test

The chi-square test is an important test amongst the several tests of significance. It is one of the simplest and most widely used non-parametric statistical test. It is a statistical measure used in the context of sampling analysis to (i) test the goodness of fit; (ii) test the significance of association between two attributes; and (iii) test the homogeneity or the significance of population variance.

$$\text{Chi-Square} = \frac{O - E}{E}, \quad \text{Reject: } X^2 > \text{Table value \& Accept: } X^2 \leq \text{Table value}$$

Where, O = observed values and E = expected values. Chi-Square has an approximate Chi-Square distribution and critical values of Chi-Square are obtained from the table of Chi-Square distribution. The expected values will be calculated with the help of Regression Analysis and Time Series Analysis assuming that the data come from the hypothesised distribution.

### 8. Diagrams & Graphs

Diagrams and graphs are visual aids, which give a bird's eye view of a given set of numerical data. They present the data in simple readily comprehensible and intelligible form. Graphical presentation of statistical data gives a pictorial effect instead of just a mass of figures. They depict more information than the data shown in the table which through light on the existing trend and changes in the trend of the data.

### C. Mathematical Techniques

Financial analysis also involves the use of certain mathematical tools such as Programme Evaluation and Review Techniques (PERT), Critical Path Method (CPM), and Linear Programming etc.

## 1.6 PROCESS ANALYSIS

In today's business environment nothing is more common than change. Organizations are always looking to improve the way business is done. Departments and divisions are challenging practices and procedures in order to improve service to customers. Through process analysis, departments can identify improvement opportunities.

Process analysis describes a family of methodologies to improve processes and, ultimately, organizations. Lean, Six Sigma and others center on process analysis. These methods use various tools to map and analyze work processes to understand how the work is really done and identify factors that lead to delays, quality problems and other forms of waste – which all raise costs.

### 1.6.1 What Is Process Analysis?

A process can be defined as "a logical series of related transactions that converts input to results or output". The process we are considering is a "business process," which can be defined as "a chain of logically connected, repetitive activities that utilizes the organization's resources to refine an object for the purpose of achieving specified and measurable results or products for internal or external customers."

Process analysis is an approach that helps managers improve the performance of their business activities. It can be a milestone in continuous improvement. Process analysis approach consists of the following:

- (1) Definition of the scope and the objectives of the study,
- (2) Documentation of the status quo and definition of performance measures,
- (3) Assessment and performance evaluation, and
- (4) Development of recommendations.

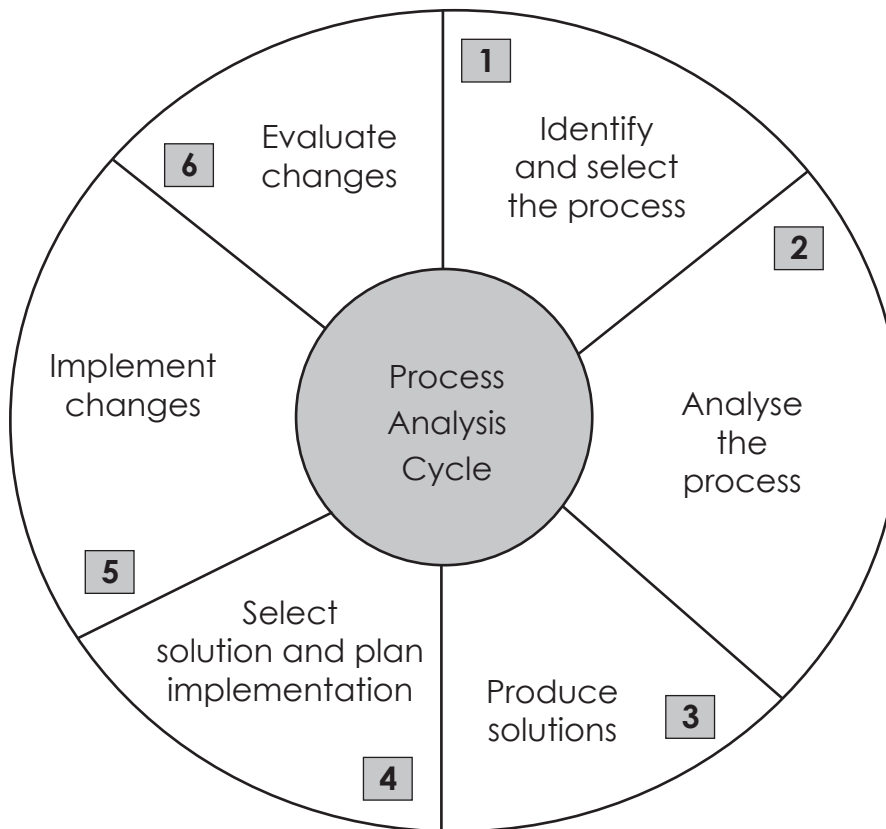

**Process Analysis Cycle**

### 1.6.2 Objectives of Process Analysis

For many organizations their goals and objectives are fulfilled once they complete the review process and the Process Capture project stops at that point. For others it is important to move beyond the basic process documents and analyse the data collected and documents.

A good strategy with analysis is to look at the process through three angles to analyse and identify areas for change.

These are **Understanding**, **Quality** and **Efficiency**. By systematically reviewing the process through each of these steps, a much improved and comprehensive analysis will result.



The objectives of analyzing the process include:

- i. Identify what makes maps difficult to understand and use
- ii. Evaluate completeness
- iii. Isolate bottlenecks
- iv. Find redundancies
- v. Examine resources allocation
- vi. Measure process times

### **1.6.3 How to do a Process Analysis ?**

Look for signs of process inefficiency or imbalance such as long queues, long wait times or large work backlogs. Also, look for underutilized functions and work cells. Areas that go for long periods without work are also indicative of a process that is out of balance.

#### **Step: 1**

##### **Interview key process participants**

Ask what they do and why they do it. Ascertain what information and other inputs are needed to perform each task. Identify the source for each input. Identify the outputs (or deliverable parts) of each task, who the recipients are and why they need what they receive.

#### **Step: 2**

##### **Conduct group interviews and brainstorming sessions**

Use group sessions to validate and refine the information you've received once you've gathered initial information about a process through one-on-one interviews. This is an excellent way to clear up misconceptions of individuals within the process.

#### **Step: 3**

##### **Identify activities and task outputs that are unnecessary**

#### **Step: 4**

##### **Sketch the business process from scratch based on the business process requirements identified during interviews and brainstorming sessions.**

Compare this process flow with the flowchart of the existing process. Identify potential process changes based on your comparison of the current process flow versus the process flow derived from requirements.



There is a fair degree of overlap among methodologies, but they differ in what they focus on and the tools they employ. Each can be very useful. It is like trying to decide which tool is the best. They are all good. The one you use depends on the job you need to do, and it's beneficial to know how to use each one.

Important shared beliefs are woven through each methodology. They form a collection of tenets that are the heart of how you manage and improve processes, regardless of which method you use.

First and foremost among these tenets is a belief that our work processes exist to serve our customers. The value of everything we do should be examined from the customers' perspective – what does and does not bring value to the people who pay for our services. Activities that do not add value to our customers (excluding regulated activities) must be strongly challenged.

Second, there is a belief that we need to know what we are talking about in order to make lasting improvements. This may seem obvious and a bit trivial, but it is not. It is hard work. We need to truly understand what our processes are and how they work. We need to know their activities and control points, their cycle times, and their cost structure. We need to make assessments, decisions and plans from positions of fact and not fiction or folklore. Data and its proper analysis are key. No more guessing. Although it is much faster and easier to simply “shoot from the hip,” this approach rarely leads anywhere but a circle.

An emphasis on accurate knowledge leads to our next common theme: we need to get the process workers involved. They live with the process every day and are a valuable source of knowledge. They are also a critical ally in gaining acceptance and implementing proposed changes. This requires good relationships with employees and committing time to let them participate. These two points can be major stumbling blocks to many organizations.

Finally, all process analysis methods view waste (in all of its forms) as the enemy and the details of the process as the battle field. Waste is woven into the fabric of our work. Removing it involves the organizational equivalent of door-to-door combat. We gain ground inch by inch and not in leaps and bounds. As much as people don't like hearing it, there aren't any quick fixes that will solve all the problems.

**So what is the upside?** These methods work when properly applied. When they become part of the work culture, they work even better. They create and distribute real process knowledge that is beneficial not only to operations, but to training, compliance, HR and IT. They engage people in work that is generally viewed as interesting and rewarding — the type of work that, when accompanied by successful improvements, energizes a work unit.

**What is the down side?** As noted earlier, process analysis requires healthy relationships and trust in order to gain cooperation. It requires effort to learn new tools and to dive into process details to get to the bottom of things. All of this takes time.

**Is it worth it?** Absolutely. If you want to create and maintain a culture of customer satisfaction, collaboration, solid performance and continuous improvement, the answer is clearly 'yes.'

#### **1.6.4 Bottleneck in a Process**

A bottleneck in a process occurs when input comes in faster than the next step can use it to create output. The term compares assets (information, materials, products, man-hours) with water. When water is poured out of a bottle, it has to pass through the bottle's neck, or opening. The wider the bottle's neck, the more water (input/assets) you can pour out. The smaller or narrower, the bottle's neck, the less you can pour out – and you end up with a back-up, or “bottleneck.”

**There are two main types of bottlenecks:**

1. **Short-term bottlenecks** – These are caused by temporary problems. A good example is when key team members become ill or go on vacation. No one else is qualified to take over their projects, which causes a backlog in their work until they return.

2. **Long-term bottlenecks** – These occur all the time. An example would be when a company's month-end reporting process is delayed every month, because one person has to complete a series of time-consuming tasks – and he can't even start until he has the final month-end figures.

Identifying and fixing bottlenecks is highly important. They can cause a lot of problems in terms of lost revenue, dissatisfied customers, wasted time, poor-quality products or services, and high stress in team members and all **Process Analysis Methods** take bottlenecks as the obstacles and tries to abolish the same.

## 1.7 SUPPLY CHAIN MANAGEMENT

### Introduction

Over the last three decades, the concept and theory of business management have undergone profound changes and development. Many old ways of doing business have been challenged and many new ideas and approaches have been created, among them are business process re-engineering, strategic management, lean thinking, agile manufacturing, balanced scorecard, blue ocean strategy, ... just to name a few. Supply chain management is undoubtedly one of those new and well grown management approaches emerged and rapidly developed across all industries around the world.

The earliest appearance of the term 'supply chain management as we know it today published in recognisable media and literatures can be traced back to the early 1980s. More precisely, it first appeared in a Financial Times article written by Oliver and Webber in 1982 describing the range of activities performed by the organization in procuring and managing supplies. However the early publications of supply chain management in the 1980s were mainly focused on purchasing activities and cost reduction related activities. The major development and the significant increases of publications in the areas of supply chain integration and supplier-buyer relationship came in 1990s when the concept as we know it today was gradually established.

It is therefore clear that supply chain management is not one of the legacy academic subjects existed for hundreds or thousands of years, but rather a young and even nascent subject. It is only recently that business world started making use of this concept. So, the question is "Why now?" A convincing answer to this question is that our business environment has changed, which includes globalisation, more severe competition, heightened customer expectation, technological impact and geopolitical factors and so on. Under such a renewed business environment, an organisation focused management approach is no longer adequate to deliver the required competitiveness. Managers must therefore understand that their businesses are only part of the supply chains that they participated and it is the supply chain that wins or loses the competition.

#### 1.7.1 Supply Chain Management

Supply Chain Management encompasses the planning and management of all activities involved in sourcing, procurement, conversion and logistics management activities. Importantly, it also includes coordination and collaboration with channel partners, which can be suppliers, intermediaries, third party service providers, and customers. In essence, Supply chain Management integrates supply and demand management within and across companies.

The Supply Chain Management Program integrates topics from manufacturing operations, purchasing, transportation, and physical distribution into a unified program. The following figure gives clear view of the Supply Chain Management.

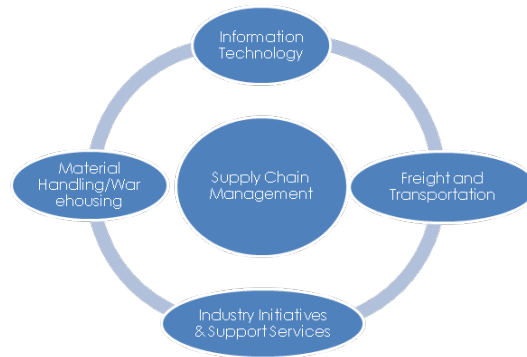

In a typical supply chain, raw materials are procured and items are produced at one or more factories, shipped to warehouses for intermediate storage, and then shipped to retailers or customers. Consequently, to reduce cost and improve service levels, effective supply chain strategies must take into account the interactions at the various levels in the supply chain. The supply chain, which is also referred to as the **Logistic Network**, consists of suppliers, manufacturing centers, warehouses, distribution centers, and retail outlets, as well as raw material, work-in-process inventory, and finished product that flow between the facilities.

Thus, we can define the Supply Chain Management as follows:

**Supply chain management is a set of approaches utilized to efficiently integrate suppliers, manufactures, warehouses and stores, so that merchandise is produce and distributed at the right quantities, to the right locations, and at the right time, in order to minimize system wide costs while satisfying service level requirements.**

#### 1.7.2 Objective of Supply Chain Management:

- i. Supply chain Management takes into consideration every facility that has an impact on cost and plays a role in making the product conform to customer requirements: from supplier and manufacturing facilities through warehouses and distribution centers to retailers and stores.
- ii. The supply chain management is to be efficient and cost-effective across the entire system; total system wide costs from transportation and distribution to inventories of raw materials, work-in-process and finished goods are to be minimized.
- iii. Finally, supply chain management revolves around efficient integration of suppliers, manufacturers, warehouses and stores; it encompasses the firm's activities at many levels, from the strategic level through the tactical to the operational level.

#### One example distinctly stated the objective of Supply chain Management:

Indian Railway (IR), which manages one of the largest railways networks of the world, has shown remarkable turnaround in recent years. With 81,511 km of track, 7,429 locomotives, 2,53,186 wagons and 40,775 coach vehicles, it is one of the preferred modes of long distance transport in India. In 2001, when it had a fund balance of paltry ₹ 3.59 billion and had to defer dividend payment, experts started saying that it has gone into a serious debt trap. In the annual railways budget presentation in Feb, 2007, Mr. Lalu Prasad Yadav, the Union Minister of Railways announced that the cash surplus before dividend has gone up to ₹ 2,00,000 million against ₹ 1,47,000 million in the previous year. This has been made possible through a series of measures like technology up gradation, improved freight loading by increasing the axle-loading capacity of wagons, market-oriented approach, use of IT and telecommunication, etc. According to Mr. Prasad, with an increase of just 1 ton in the loading capacity of a wagon, the annual loading capacity goes up by about 10 million tons. Just this measure has improved the IR annual Loading capacity by a whopping 170 MT in the last three years.

### 1.7.3 Component of Supply Chain Management:

There are five basic components of Supply Chain Management. These are showing in the diagram:

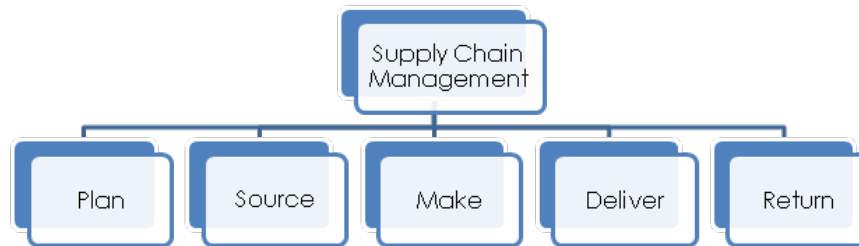

1. **Plan:** This is the strategic portion of SCM. You need a strategy for managing all the resources that go toward the meeting customer demand for your product and services.
2. **Source:** Choose the suppliers that will deliver the goods and services you need to create your product. Develop a set of pricing, delivery and payment processes with suppliers and create metrics for monitoring and improving the relationships.
3. **Make:** This is the manufacturing step. Schedule the activities necessary for production, testing, packaging and preparation for delivery.
4. **Deliver:** This is the part that many insiders refer to as logistics. Coordinate the receipt of orders from customers, develop a network of warehouses, pick carriers to get products to customers and set up an invoicing system to receive payments.
5. **Return:** The problem part of the supply chain. Create a network for receiving defective and excess products back from customers and supporting customers who have problems with delivered products.

### 1.7.4 Importance of Supply Chain Management

In the ancient Greek fable about the tortoise and the hare, the speedy and overconfident rabbit fell asleep on the job, while the “slow and steady” turtle won the race. That may have been true in Aesop’s time, but in today’s demanding business environment, “slow and steady” won’t get you out of the starting gate, let alone win any races. Managers these days recognize that getting products to customers faster than the competitor will improve a company’s competitive position. To remain competitive, companies must seek new solutions to important Supply Chain Management issues such as modal analysis, supply chain management, load planning, route planning and distribution network design. Companies must face corporate challenges that impact Supply Chain Management such as reengineering globalization and outsourcing.

Why is it so important for companies to get products to their customers quickly? Faster product availability is key to increasing sales, says R. Michael Donovan of Natick, Mass., a management consultant specializing in manufacturing and information systems. “There’s a substantial profit advantage for the extra time that you are in the market and your competitor is not,” he says. “If you can be there first, you are likely to get more orders and more market share.” The ability to deliver a product faster also can make or break a sale. “If two alternatives [products] appear to be equal and one is immediately available and the other will be available in a week, which would you choose? Clearly, **“Supply Chain Management has an important role to play in moving goods more quickly to their destination.”** “

#### **An example of a Supply Chain Management application: To Reduce Cycle Time, Kick Those Bad Habits.**

One of the chief causes of excessive order-to-delivery cycle times is the existence of longstanding “bad habits” that result when companies fail to revise internal processes to reflect market changes. The existence of separate, independent departments tends to perpetuate these inefficient practices. Taking the supply-chain management view, on the other hand, helps companies identify the cumulative



effects of those individual procedures. Eliminating such bottlenecks improves product availability and speeds delivery to customers-both of which can increase sales and profits.

**The case :** Consultant R. Michael Donovan illustrates the point with the tale of a client that manufactures a made-to-order machine part. Average order-to-delivery time varied between six and nine weeks. As a result, the manufacturer was losing business to “replicators” that could produce low-quality “knockoff” versions in just three weeks. Donovan and his colleagues analyzed the manufacturer’s entire supply chain, from order entry and raw-materials supply all the way to final delivery.

**They found problems at every step of the way:** Handwritten orders were being rekeyed into the materials-planning system on weekends, which meant that some orders were sitting around unprocessed for an entire week. On Monday mornings, production control would be overwhelmed with a week’s worth of orders. It often took them several days to plow through the backlog and issue manufacturing orders.

Once those orders had been cut, the engineering department required one week to produce technical drawings. They needed several more days to match up drawings with orders and other documentation. Those information packets then would go to the manufacturing line, where the scheduling system allowed three weeks’ time for production. “Orders could be sitting there for almost three weeks before going into production, even though the actual time required producing an item ranged from a few hours to one full day,” Donovan recalls.

**The solution :** Supply Chain experts were able to slash order-processing time, including the generation of engineering drawings, from about two and a half weeks to one day. They made some alterations to the manufacturing process to speed up production. While they were cutting waste out of physical processes, the consultants also were finding ways to speed up the flow of information and to improve the accuracy of production orders. Today, materials flow is closely correlated with information flow, and lead times have been cut from an average of six to nine weeks down to fewer than three weeks.

**The payoff :** The payoff has been enormous. Instead of steadily losing market share to the replicators, the manufacturer has doubled sales volumes. It has reaped an added benefit as well: Because quality remains very high, the manufacturer has been able to charge more for its products, generating even greater profits.

Donovan proudly notes that this radical change was achieved with technologies the manufacturer already had. “We didn’t change the technology, we just changed how it was applied,” he says. “The magic is not in the software. Information technology should not be the driver of re-engineering the order-to-delivery process,” he concludes. “It should enable you to achieve your objectives.”

**Source: SUPPLY-CHAIN MANAGEMENT REPORT**

**“It’s about time- Supply-chain management and time-based logistics together can give companies an unbeatable opportunity to increase profits “ by Toby B. Gooley -Senior Editor**

### **1.7.5 Development of Supply Chain Management:**

The development of chain is the set of activities and processes associated with new product introduction. It includes the product design phase, the associated capabilities and knowledge that need to be developed internally, sourcing decisions and production Plans. Specifically, the development chain includes decisions such as product architecture; what to make internally and what to buy from outside suppliers, that is, make /buy decisions; supplier selection; early supplier involvement; and strategic partnerships.

The development and supply chains intersect at the production point. It is clear that the characteristics of and decisions made in the development chain will have an impact on the Supply Chain. Similarly, it is intuitively clear that the characteristics of the supply chain must have an impact on product design strategy and hence on the development chain.



**For Example:**

Hewlett Packard (HP) was one of the first firms to recognize the intersection of the development and supply chains. A case in point is the inkjet printer introduction, where decisions about product architecture were made by taking into account not only labour and material cost, but also total supply chain cost throughout the product life cycle. More recently, HP has focused on making decisions such as what design activities to outsource and the corresponding organizational structures needed to manage the outsource design process by considering the characteristics of both the development and supply chains.

Unfortunately, in most organizations, different managers are responsible for the different activities that are part of these chains. Typically, the VP of engineering is responsible for the development chain, the VP of manufacturing for the production portion of the chains, and the VP of supply chain or logistics for the fulfillment of customer demand. Unless carefully addressed, the typical impact of this organizational structure is a misalignment of the product design and supply chain strategies.

To make matters worse, in many organizations, additional chains intersect with both the development and the supply chains. These may include the reverse logistics chain, that is, the chain associated with returns of products or components, as well as the spare – parts chain. We illustrate how the consideration of these characteristics leads to the development of frameworks to assist in matching product strategies.

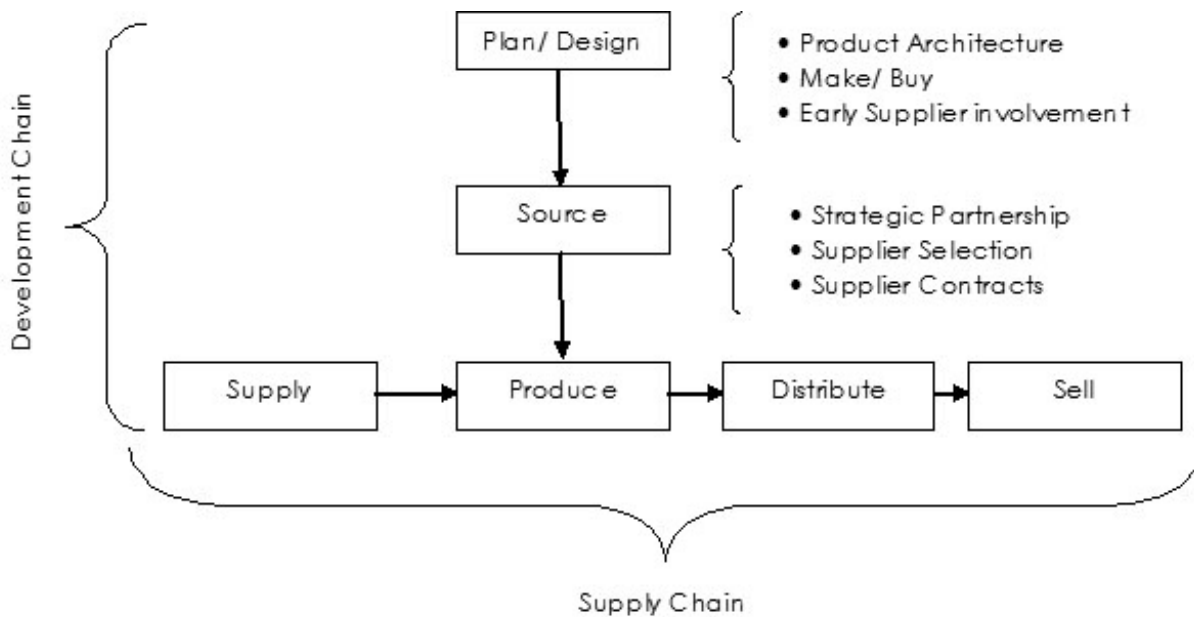

Global optimization is made even more difficult because supply chains need to be designed for, and operated in, uncertain environments, thus creating sometimes enormous risks to the organization. A variety of factors contribute to this:

1. **Matching Supply and Demand:** It is a major challenge:
  - a. Boeing Aircraft announced a write-down of \$ 2.6 billion in October 1997 due to “Raw Material Shortages internal and supplier parts shortages and productivity inefficiencies”.
  - b. “Second quarter sales at U.S. surgical Corporation declined 25 percent, resulting in a Loss of \$22 million. The sales and earnings shortfall is attributed to larger than anticipated inventories on the shelves of hospitals.”

- c. “Intel, the world’s largest chip maker , reported a 38 percent decline in quarterly profit Wednesday in the face of stiff competition from Advanced Micro Devices and a general slowdown in the personal computer market that caused inventories to swell”.

Obviously, this difficulty stems from the fact those months before demand is realized; manufacturers have to commit themselves to specific production levels. These advance commitments imply huge financial and supply risks.

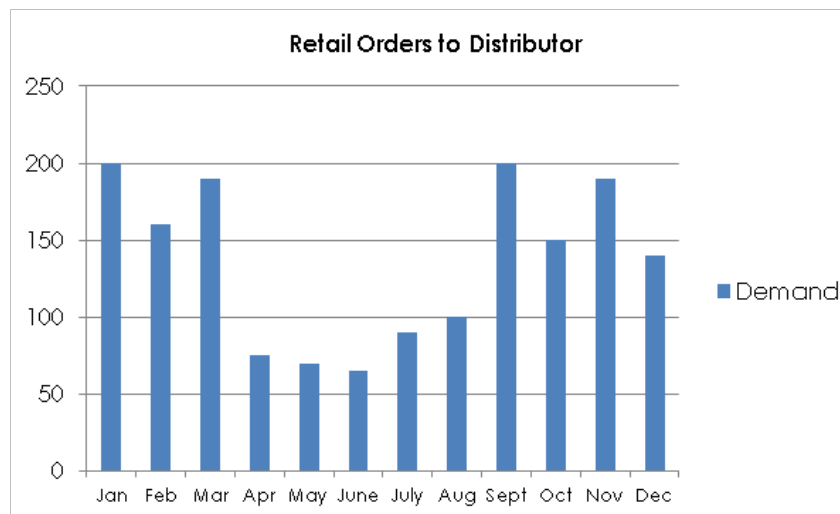
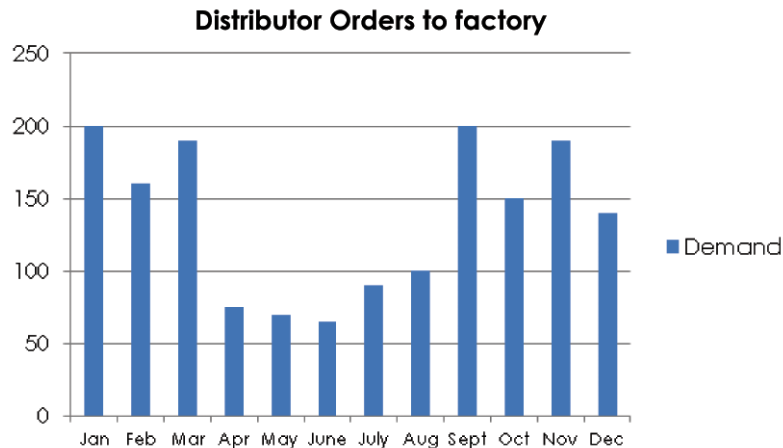

2. **Inventory and back – Order levels fluctuate considerably across the supply chain:** Even when customer demand for specific products does not vary greatly. To illustrate this issue, consider the above figure, which suggests that in typical supply chain, distributors orders to the factory fluctuate far more than the underlying retailer demand.
3. **Forecasting does not solve the problem:** Indeed, we will argue that the first principle of forecasting is that “Forecasts are always wrong.” Thus, it is impossible to predict the precise demand for a specific item, even with the most advanced forecasting technique.
4. **Demand is not the only source of uncertainty:** Delivery leads times, manufacturing yields, transportation times, and component availability also can have significant chain impact.
5. **Recent trends such as lean manufacturing, outsourcing and off shoring that focus on cost reduction increases risk significantly.**

For example, consider an automotive manufacturer whose parts suppliers are in Canada and Mexico. With little uncertainty in transportation and a stable supply schedule, parts can be delivered to assembly plants “Just –In- Time” based on fixed production schedules. However, in the event of an unforeseen disaster, such as the September ‘11 terrorist attacks, Port strikes, January, 26, 2001 earth quake in the India, state of Gujrat,etc.

Although, uncertainty and risk cannot be eliminated, we will explore a variety of examples that illustrate how product design, network modeling, information technology, procurement and inventory strategies are used to minimize uncertainty, and to build flexibility and redundancy in the supply chain in order to reduce risks.

**Case Study**

**1. FOOD CORPORATION OF INDIA: SUPPLY CHAIN MANAGEMENT**

Food Corporation of India (FCI) was established under the Food Corporation of India Act 1964 for the purpose of trading in food grains and other foodstuffs. The Act extended to the whole of India. The Corporation acts as a body corporate. The general superintendence, direction and management of the affairs and business of the Corporation vests in a board of directors, which exercises all such powers and does all such acts and things as may be exercised or performed by the Corporation under the FCI Act.

FCI performs the major functions of procurement, storage preservation, movement, transportation, distribution and sale of food grains and meets the requirements of Public Distribution System (PDS) in the country. In other words, it handles or manages the entire supply chain in food grains distribution in India. It acts as a nodal agency of the central government based on ethical business principles having regard to the interest of the producers (farmers) and consumers.

Supply chain management of food grains by FCI is actually a joint responsibility of the Central Government, the state governments and the union territories involved in the actual implementation of PDS. Functions of the centre are to procure, store and transport. The implementation and administration of PDS is the responsibility of the state government and the UT administration. They lift these commodities from central godowns mills and distribute them to consumers through the massive network of fair price shops. Monitoring, inspection and enforcement of legal provisions is also done by the state government and the UT administration.

The network of fair price shops (FPS) has been expanding over the years, adding to the supply chain. During the last decade, the number of fair price shops had increased from 3.61 lakh (1990) to 4.59 lakh (2004) as indicated in the following:

**Increase in No. of Fair Price Shops**

Year	No. of FPS (in lakhs)
1985	3.19
1987	3.38
1990	3.61
2004	4.59

An efficient supply chain management requires the establishment of a close link between production, procurement, transportation, storage and distribution of selected commodities. Infrastructure needs to be strengthened, particularly in the backward, remote and inaccessible areas. The system also needs to be much improved to make it cost-effective. There is need for buffer stock in such a system. But, buffer stock can be reduced by timely procurement, transportation and storage.

This would reduce the carrying costs of the goods meant for distribution. The costs can also be reduced by increasing efficiency in the distribution network.

Leakages during the movement of food grains, etc., need to be plugged. Proper and timely checks



of the fair price shops, godown, etc., can also lower the cost of PDS operations and the total supply chain management. FCI has to ultimately ensure a cost-effective supply chain and, for this, appropriate modalities have to be worked out.

## **2. Creating shared value in the supply chain A Nestlé case study**

Nestlé is the world's leading nutrition, health and wellness company. It employs around 330,000 people and has 461 factories in 83 countries around the world; almost half of these are in developing countries.

Nestlé producing some of Britain's most popular brands such as KITKAT, NESCAFÉ, SMARTIES, GO CAT and SHREDDIES. Over one billion KIT KATs are produced in the UK every year.

### **Nestlé's culture**

Nestlé works within the secondary sector of industry, creating and supplying products to customers. It converts raw materials into finished goods for consumers to enjoy. Raw materials used in many of Nestlé's products are sourced from the primary sector. For example, Nestlé brands such as KIT KAT, AERO and SMARTIES contain cocoa sourced from cocoa farmers around the world.

Nestlé works with cocoa farmers in order to help them run profitable farms and eliminate child labour, whilst developing a sustainable supply of cocoa for Nestlé products.

This case study looks at the importance of applying the principles of corporate social responsibility to a business' activities. It will demonstrate how Nestlé creates shared value within its cocoa supply chain to enhance the lives of cocoa farmers whilst also improving the quality of its products for consumers.

### **Corporate Social Responsibility**

In Business Studies curriculum terms, Corporate Social Responsibility (CSR) involves the business taking a broad view of its activities, looking beyond profits for shareholders and focusing on other stakeholders. A stakeholder is anyone that has an interest in or may affect the decisions and actions of a business.

Stakeholders can be internal or external to the business. Internal stakeholders include employees and shareholders. External stakeholders include suppliers, customers, the communities in which the business operates and the environment.

For companies like Nestlé, which work with suppliers from a range of countries, many in poorer regions of the world, it is becoming increasingly important to take a wider view of responsibilities. Nestlé believes for a company to be successful in the long term and create value for its shareholders, it must also create value for society. It calls this Creating Shared Value.

### **Creating Shared Value**

Creating Shared Value has become an integral part of the way in which Nestlé does business. It is based on compliance with international laws and codes of conduct and the company's business principles, and a focus on environmental sustainability. However, Creating Shared Value goes beyond compliance and sustainability. It aims to create new and greater value for society and shareholders in the areas where the company can have the biggest impact – nutrition, water and rural development. These are core to its business activities and vital for its value chain:

- Water: because the ongoing quality and availability of it is critical to life, to the production of food and to Nestlé's operations.
- Rural development: because the overall well-being of farmers, rural communities, workers and small businesses and suppliers is intrinsic to the long-term success of Nestlé's business.
- Nutrition: because food and nutrition are the basis of health and of Nestlé's business as the leading Nutrition, Health and Wellness company.

### **Partnerships**

Nestlé actively seeks engagement and partnerships with external stakeholders to optimize positive

impact. It aims to use the power of its core activities and partnerships for the joint benefit of the people in the countries where it operates and of its shareholders.

Global principles and goals set by organizations such as the United Nations also help to shape a company's approach to corporate social responsibility. For example, Nestlé's Corporate Business Principles incorporate the 10 United Nations Global Compact Principles on Human Rights, Labour, the Environment and Corruption. Nestlé is an active member of several of the Compact's Working Groups and Initiatives.

### **Creating Shared Value along the supply chain**

Supply chain activities transform natural resources and raw materials into finished products which are delivered to the end consumer. Each stage of the process adds value to the overall end product.

Nestlé operates within complex supply chains. Its cocoa supply chain goes from cocoa bean to chocolate bar. This path starts with cocoa from farmers, who grow the crops; to cooperatives, which manage the sale of the crops; to processors and manufacturers, such as Nestlé which create chocolate products; to retailers such as supermarkets, and finally to consumers who purchase the products.

Nestlé sources materials from thousands of farms, many of them small farmers in poorer rural regions of the world. In many rural communities, a lack of investment in infrastructure has a serious impact on the quality and quantity of raw materials that Nestlé and other companies rely on. Nestlé provides training in order to encourage sustainable production, protect the supply and quality of its raw materials and have a positive, long-term impact on the local economy and farmers' standards of living.

Around two-thirds of Nestlé's worldwide expenditure is on raw materials. Nearly 40% of this goes on three main ingredients: milk, coffee and cocoa. Cocoa is the main ingredient in chocolate and as such is vital to Nestlé. It comes from cocoa beans that grow in a pod on a cocoa tree.

### **The Nestlé Cocoa Plan**

The Nestlé Cocoa Plan was launched in October 2009 in the Côte d'Ivoire, Africa. It is a prime example of Nestlé's Creating Shared Value approach to business and involves investment of £67 million between 2010 and 2020, building on £37 million in the 15 years before the plan. The initiative aims to help cocoa farmers to run profitable farms, respect the environment, have a good quality of life and give their children a better education.

However, it also aims to ensure a sustainable and high quality supply of cocoa for Nestlé in the long-term. Some of the areas it focuses on to achieve this are: improved farmer training, buying from cooperatives and paying a premium, and working with certification programmes such as Fair trade. This creates value through the supply chain, particularly for farmers and their families along the way.

The Cocoa Plan has become a key way in which Nestlé is tackling issues facing cocoa farmers as well as their families and communities. Nestlé sources most of its cocoa production from Côte d'Ivoire. Both the quality and quantity of cocoa supplies are in decline. The average cocoa farmer is over 55 years old and so the industry needs to consider where the next generation of cocoa farmers will come from. Many younger people in the region are leaving the countryside to work in cities. As a result there is a shortage of labour and skills. Ultimately, the aim is to raise the standard of living of cocoa farmers to ensure a new generation of cocoa farmers will take over and benefit.

### **Benefits of responsible behaviour**

The Cocoa Plan is a clear example of Nestlé Creating Shared Value both for the company and for cocoa farmers, their families and their local communities. Through it, Nestlé benefits from ensuring the supply of high-quality and sustainably sourced cocoa for its products. It also ensures it supports the cocoa farming community development and meets certified ethical and environmental standards.

### **Nestlé's focus on improving supply has delivered benefits in many areas:**

- **Investing in plant research** - By developing higher quality seedlings which produce typically 50%–



200% more cocoa, this enables cocoa farmers to grow more and sustain a higher income. Nestlé has set up a Research and Development Centre in Abidjan in the Côte d'Ivoire to support the development of higher-yielding, disease-tolerant cocoa plantlets.

- **Investing in training farmers** – Training farmers to understand better crop management techniques and pest management, as well as improving their awareness of child labour issues, helps to improve outputs and boosts farmers' incomes.
- **Improving social conditions** – Nestlé has set up a partnership with the World Cocoa Foundation to build and repair schools within the cocoa farming regions and support cocoa farmers and their families. This will mean that attending school will become a more attractive and viable option for parents and children and that the risk of child labour will be reduced.
- **The Fair trade and UTZ labels** – Crops are certificated under the Fair trade label. Nestlé pays a premium for its cocoa beans, which improves the growers' levels of income and helps to secure the future growth of communities. Nestlé is also the first food company to join the Fair Labour Association (FLA) and has its work in Côte d'Ivoire assessed openly and independently.

The Cocoa Plan is an evolving and growing program. Each year more cooperatives of farmers are being added to the plan. The plan has also been extended to other countries such as Indonesia, Ghana, Venezuela and Ecuador.

### **Communicating with stakeholders**

Effective communication with stakeholders is also an important element of responsible business behaviour. For Nestlé, engaging with stakeholders underpins Creating Shared Value. It enables to identify emerging issues, shape its responses and continue to drive improvements in its performance. Topics raised by stakeholders are discussed with them in a variety of local and international forums. These include: nutrition, health and wellness; education and access; Nestlé's role in public policy issues; auditing and disclosure of infant formula marketing practices; and food safety.

### **Nestlé engages with stakeholders through a variety of ways. For example:**

- Through Nestlé's annual reports and Creating Shared Value reports, stakeholders can see where funds are invested, how the company is addressing issues such as environmental performance and the positive impact of Creating Shared Value activities.
- Stakeholder convening's, held in various countries where Nestlé has operations, communicate its approach and invite feedback on its Creating Shared Value efforts.
- The Nestlé Supplier Code establishes the minimum standards that its suppliers, their employees, agents and subcontractors need to meet. This demonstrates how Nestlé is committed to developing responsible practices right through its supply chain.
- The Nestlé corporate website contains information on all company policies, principles and activities.
- There are dedicated websites to key projects such as the Cocoa Plan. These sites bring together all the detail of the initiative in an easy-to-read and understandable way.
- This case study aims to help to reveal to young people the complexities of global supply chains and how companies such as Nestlé respond to these issues.

The Cocoa Plan has led to numerous partnerships with other organizations such as the Fair Labour Association and the Red Cross/Red Crescent societies. These relationships help Nestlé to fight illegal labour practices. Nestlé also has partnerships with supply chain organizations and governments which support good agricultural practices. These practices have created benefits for stakeholders across the industry, including consumers, shareholders, farmers and other partners. For example, one partnering initiative with the Co-operative Group is paying for educational packs for schools in the Côte d'Ivoire region.

Creating Shared Value has enabled Nestlé to adopt a wider focus to its responsibilities. In doing so, it has been able to bring about a whole series of benefits to stakeholders, whether they are farmers and their communities, shareholders or consumers.

The Cocoa Plan is Nestlé's way of dealing with issues facing cocoa farmers and their communities. This is a long-term process that has created better outcomes for all involved in the cocoa industry. It has enabled Nestlé to support local communities as well as improving both the quality and output of cocoa.

### **3. Developing a sustainable supply chain to add value-A Lafarge case study**

#### **Introduction**

The Lafarge Group is the world's largest supplier of building materials and has a global reputation for developing creative and innovative products, services and solutions. The company produces essential products – cement, aggregates and concrete – which are integral to society. Cement and concrete are basic materials in all walks of life – everyone relies on the country's infrastructure such as roads, hospitals, power stations, housing and railways.

Lafarge is facing many interesting challenges. As a major extractor of raw materials in the primary sector, issues of sustainability and corporate social responsibility are of high importance. The drive for increased sustainability affects every part of Lafarge's activities – from extraction and manufacture, to transport and delivery, to waste reduction and restoration.

#### **Lafarge's values**

Managing health and safety for employees, contractors, the wider public and environment throughout these processes is vital. Lafarge believes that 'No task is so important that anyone should get hurt doing it' (Dyfrig James, President Lafarge UK). It has a stated goal of 'Zero Harm' – that is, zero accidents, incidents or job-related illness. This objective applies to employees, its supply chain and the public.

This case study will explore how Lafarge UK is active in all three sectors of industry and how it manages the need to develop the business alongside protecting the environment and respect for local communities.

Sectors of industry and sustainable supply chains

Business activities may be classified by the type of production that takes place. All activities fall into one of the following three sectors of industry:

- Primary – involving the extraction of raw materials or the growing of crops
- Secondary – involving a transformation of raw materials into finished goods
- Tertiary – covering the provision of services.

Certain key industries in the UK, such as steel and cement, have experienced growth, with new technologies and innovation driving demand. Lafarge therefore needs more people with both specialist and generalist skills to meet that growth.

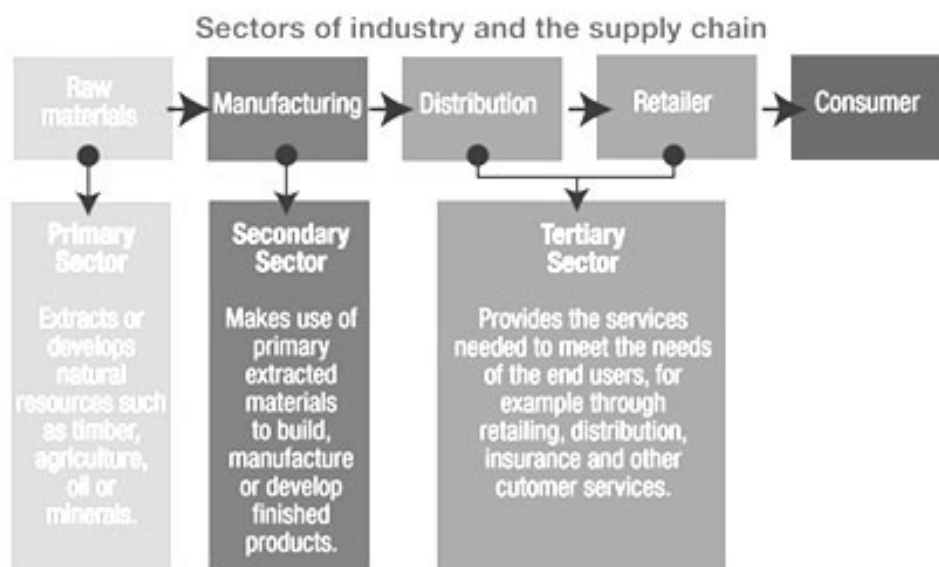

The interdependence between the sectors is known as the 'chain of production'. This identifies the interlinked stages that a product goes through from raw materials to arriving at the final customer. Each stage adds value to the previous one. A sustainable supply chain aims to ensure that the business is conducted in a manner which can be maintained in the future and which does not impact adversely on future generations. The key challenge is to deliver products and services that give value to the business and the customer, whilst maintaining a positive environmental impact.

Lafarge operates in all three sectors of its industry, extracting raw materials, manufacturing finished goods and providing sales and after-sales service for customers. In this way, Lafarge is able to take control of and manage not just operational efficiencies but also quality, health and safety and its impact on the environment.

### Primary sector

In its primary sector activities, Lafarge's extraction processes involve drilling or controlled explosions to blast limestone, granite, shale or clay from quarries. This provides the raw ingredients required to make cement, aggregates and concrete. The rock is transported to a crusher to produce the different sizes of rock needed to suit different products for customers.

### Sustainability

Lafarge is committed to sourcing its materials and managing extraction in the most responsible and sustainable way possible. Rock quarries are usually operated for many decades and then restored. Sand and gravel quarries are shallower than rock quarries and can be worked in stages. This means the land is used and restored in phases. As the majority of raw materials to make cement come from new quarries, Lafarge is also investigating how it can reduce dependence on these sources. It is looking at ways of treating waste and by-products from other industries to replace natural materials. This is an important aspect of its sustainable practices.

In addition, it works with external bodies such as the Environment Agency in the planning stages of assessing a new quarry site. This means Lafarge can take into account key issues affecting the environment from the outset. At the end of the quarry's life, Lafarge is committed to the restoration of land. For example, it uses recovered inert waste from its extraction and waste management processes as part of the restoration process.

It then works in partnership with other organizations (such as the Staffordshire Wildlife Trust) to re-use the land for the good of the community and to provide a lasting legacy. For example, the National Memorial



in Staffordshire is on a former quarry site. Lafarge has also been involved in managing 34 SSSIs (Sites of Special Scientific Interest), as well as creating award-winning parks, lakes and education centers. Over 700 SSSIs have been developed in the UK from former sites of mineral operations.

### Secondary sector

A business will aim to add value (both financial and non-financial) as a product moves from inputs to outputs across the three sectors of industry.



Globally Lafarge invests over 170 million Euros every year into research and development. This makes it one of the world's leading research and development companies. This investment helps to provide ongoing innovation in its secondary sector production processes which benefits customers. Its skilled chemists and scientists work in laboratories across the UK. For example, it created a self-compacting concrete called Agilia. This saves customers' time and money in the construction process.

It creates value for the client due to less time being needed for application and lower costs of equipment. This also contributes to a healthier environment for construction workers.

The manufacturing process to create cement involves heating the raw materials to a very high temperature, grinding the clinker finely and adding different minerals to the resulting cement to give different properties. Important properties customers look for include increased resistance to weather or a higher quality finish. Lafarge is the leader in the development of low carbon cement products and has five main manufacturing locations, producing 5 million tons of cement each year.

### Reviewing Processes

By its nature, cement manufacturing consumes large amounts of non-renewable resources and also generates CO<sub>2</sub>. Lafarge is therefore committed to reviewing its processes to reduce its impact on the environment. Its production plants are certified under British Standards for both quality and environmental management. One way in which Lafarge helps to minimize its impact and emissions is by having on-site concrete production plants for large-scale projects. This is more efficient and enables Lafarge to provide continuous supply throughout the life of the project.

As a major user of significant amounts of water in its processes, Lafarge is also piloting 'water footprint' assessments. These aim to use water more efficiently and reduce consumption where possible. Other examples of Lafarge's 'best practice' include:

- using the fly-ash waste product from iron and steel smelting to make low-carbon cement
- using alternatives to fossil fuels (such as chipped used tyres) in the kiln heating process
- investing in more efficient manufacturing units
- Offering a cement recycling service to customers for unused, outdated bags of products.

Lafarge also takes innovation right through the supply chain into its packaging. Its weather-resistant plastic packaging is easier to handle and is tear resistant. Both effects benefit customers. Plastic packaging for cement perhaps surprisingly, is more sustainable than paper as less material is lost through damaged bags, which is better for the environment.

### Tertiary sector

At the later stages of the supply chain, Lafarge's activities in the tertiary (or service) sector range from transporting finished goods to providing a specialist advice and after-sales service for customers. This ensures they get the best use of the products.



Lafarge supplies its products in large volumes to intermediaries, such as local authorities or building companies, where the products are used on major projects. An example is Terminal 5 at Heathrow Airport.

Lafarge uses different means of transport – road, rail and water – to help it reduce carbon emissions wherever possible. Lafarge has a fleet of road vehicles for transporting bulk cement. It has modernized the fleet to increase the loads each tanker can carry in order to reduce the number of vehicles on the road and reduce emissions. Of its nationwide network of 14 depots, 11 have direct rail access. More than one million tonnes of cement a year is moved by rail, more than any other company. This removes hundreds of thousands of vehicles off the roads each year, reducing congestion, pollution and CO<sub>2</sub> emissions. Lafarge is also an expert in transporting by water.

### **Adding value**

One important area of added value for customers is through Lafarge's Construction Solutions and Contracting services. Its technical sales people, along with IT, purchasing and customer service teams, provide ongoing support and advice for customers.

- Lafarge Contracting specializes in providing asphalt based solutions for surfacing projects. These might be as wide ranging as car parks, race tracks, bus lanes, housing developments and airport runways.
- Construction Solutions uses all Lafarge's expertise, from aggregates to cement, to offer a 'one-stop-shop' service. This provides all the expertise and materials to take a project from initial design, through production, to finished installation in one combined service.

Lafarge continues to demonstrate its innovation and sustainability in the tertiary sector. As part of its sustainability plans, Lafarge goes beyond simply managing or restoring its extraction sites. By adopting the principles of re-using waste products from other industries, Lafarge can respond to environmental challenges in a sustainable way:

- Its energy recovery service recycles used tyres for fuel.
- Landfill sites have processes for separating out waste in order to recover re-usable materials.

To generate the cement and concrete that the building industry needs, it is necessary to extract raw materials from the earth. In order to minimize the impact its activities have on the environment and create a sustainable business, Lafarge has put in place principles and best practices across its integrated supply chain.

By focusing on re-use, recycling and reducing emissions in every stage, from initial planning of a quarry, to final restoration of the land, Lafarge is maintaining a sound business whilst respecting the environment and supporting local communities.

Lafarge continues to be heavily involved in restoration projects such as the newly completed Chalk Grassland project in Kent which has restored 40 hectares of grassland for sheep grazing. It is also in partnership with the RSPB at a prospective project at the Dunbar Works in Scotland, where the quarry site is being transformed into a nature reserve.

## **4. Delivering Service Excellence In The Supply Chain A Kraft Foods UK case study**

### **Introduction**

This case study looks at how a major food company has built a Customer Service Excellence Programme to ensure that its products are in the right place, at the right time, in the right quantity, in excellent condition and at the lowest possible supply chain cost.

Kraft Foods is the world's second largest food company with an annual turnover in 1999 of some £18.7 Billion and UK sales in excess of £550m.

### **Accelerating the Growth of Its Power Brands**

In the modern global economy a Power Brand is a brand which delivers a competitive advantage based around three key areas; quality, value and trust. The four key Power Brands in Kraft Foods' UK business are, The Kenco Coffee Company, Philadelphia, DairyLea and Terry's Chocolate Orange.

Driving For Improved Quality and Service at the Lowest Effective Cost

The Kraft Foods Supply Chain function is challenged with providing excellent operational support which helps to deliver continued Power Brand growth.

This is reflected in the Supply Chain goal of 'exceeding customer expectations in quality of product and service at lowest effective cost'. This is the basis for their 'Golden Triangle' model.

### **Service Excellence Program**

To help in consistently delivering against its objectives, Kraft Foods has developed a model known as the Service Excellence Programme which creates a strong supply chain relationship between the company, as the supplier and its customers, the retailers.

The programme interlinks a series of proven, simple concepts that drive customer service up and cost out from the joint Supply Chain.

### **The Service Excellence Program Jigsaw**

Kraft Foods has developed a jigsaw model to represent its Service Excellence Programme pictorially.

The 9 component pieces establish a framework around which Kraft Foods and its Supply Chain partners can build, implement and evaluate projects with the aim of improving day to day operational efficiency.

Each component piece captures the processes, activity and behavior that will deliver service excellence.

Service Excellence Programme 'piece by piece'

### **Perfect ordering**

Focuses on the successful management of a customer order from the moment it is compiled at the customer, its processing through Kraft Foods' order systems to the point of delivery at the customer warehouse. Any 'waste' that could cause delay or disruption should be eliminated. The order should be compiled correctly using accurate data, sent at agreed timings with jointly agreed delivery windows. Ideally the order is electronically communicated using EDI or the Internet.

### **Knowledge exchange**

Involves a complete understanding of the joint Supply Chain including business systems and processes operating between Supply Chain Partners. This can be delivered in many ways, from a simple one day induction for the customer at the supplier premises or longer term assignments, e.g. job swaps. The overall aim should be to build a comprehensive shared knowledge base of systems, people and processes.

Increasingly e-commerce is improving communication with the use of e-mail and extranets making contact and the sharing of knowledge and information faster and easier.

### **Seasonal planning**

Good Seasonal Planning ensures the supply chain operates smoothly through events such as:

- annual celebrations - Christmas, Mother's Day, etc
- seasons - spring, summer, autumn and winter
- special events - World Cup, Olympics, Millennium, etc.



Demand from consumers will fluctuate dramatically during seasonal periods. The supply chain will need to react accordingly and flexible plans and processes are critical for success.

Seasons challenge the supply chain to deal with an increased volume of product in a very short space of time. Planning for a season will include the sharing and learning from historical forecast information, agreeing purchase quantities, arranging delivery timings and ensuring identical product specification data is held on Kraft Foods' and its customers' databases.

### **Delivery interface**

Involves the fast and efficient transfer of products from the supplier to the customer. To move stock efficiently Kraft Foods and its Customers need to understand each other's distribution operations. At Kraft Foods, sufficient resources need to be in place to compile the order on time and reflect specific customer requirements; for example, goods delivered on pallets may not exceed certain heights.

The order needs to be dispatched on time and in the correct type of vehicle. Delivery of the order will be required at the receiving depot at the agreed time. Should errors or discrepancies arise there should be agreed processes which deal with claims or complaints.

### **Great people**

Kraft Foods believes that a truly excellent Supply Chain relationship with its Customers cannot be achieved without great people who are professional, trustworthy, helpful and responsive to customer needs. Kraft Foods defines great people as those with a passion for customer service and with the skills and behaviour required to build a Supply Chain partnership. This is why it is the central piece of the jigsaw.

Kraft Foods' employees need to listen, observe and act only when they have understood all the information. They should maintain a positive outlook in difficult situations and apply their knowledge in a supportive and constructive way.

### **Optimal inventory**

Having enough stock (or inventory) of a product to satisfy customer demand, whilst not holding excess stocks sitting idle and getting old, is the goal of optimal inventory.

To optimize the inventory levels in the total supply chain, trading partners need to collaborate fully to understand the volume and type of inventory held along the chain and the future demands, to ensure production of a product takes place at the right time and is available for the customer and fresh for the consumer.

Stock may be held at manufacturing plants, warehouses or at the retailers' stores. Information on stock levels and sales can be shared using new technologies like the Internet. The systems enable Kraft Foods and its Customers to view and act upon the same information at the same time creating a 'total Visible Inventory Chain'.

### **Data alignment**

For the supply chain to run efficiently, the supplier and the customer need to hold the same data about a product. This will include product description, number of units in a case, number of cases on a pallet, or bar codes and product information, such as detail on the product shelf life. Each area within the supply chain will use the information for a variety of purposes, for example the correct transmission of an order via Electronic Data Interchange (EDI) will require the use of the TUC code at the customer and Kraft Foods order management stages. At the customer depot, shelf life and product descriptor information will be checked.

Regular cross checks will ensure compatibility of data. Increasingly technology aids the process through use of extranets. Looking to the future, electronic 'catalogues' of information viewed on the internet and accessible by the supplier and customer will make this process easier and more efficient.

### **Variant management**

There are times when products change, such as promotional product (e.g. a chocolate bar marked with a reduced price), new products into the marketplace or the jointly agreed substitution of one product for another.

Variant management is about successfully managing product change without affecting service. It is fundamental that Kraft Foods and its customers fully understand and have in place a process to manage:

- Changes to new product specifications
- Different order quantities and delivery timings
- Changes in demand expected from the consumer.

### **Consumer satisfaction**

At the end of the supply chain is the consumer, like you. It is key to Kraft Foods and its Customers that the consumer is 100 per cent satisfied with their purchase. This can, in part, be achieved by delivering a high quality product in perfect condition every time. If this does not happen it is essential that it is resolved efficiently and speedily to the consumer's satisfaction.

The Consumer Satisfaction 'piece' defines the ideal complaint management process, specifically:

- How Kraft Foods and its Customers should handle consumer complaints.
- The mechanism for resolving the Supply Chain problem which caused the complaint.
- A crisis management policy for recall of product which may have a quality issue.
- A feedback route for consumer comments and suggestions e.g. a link to the Kenco Free phone Coffee Advice line.

### **Benefits Of The Service Excellence Program**

Through implementing these programmes with its customers, Kraft Foods has been able to substantially improve the quality of service through:

- Improved understanding of the total supply chain.
- More efficient order and delivery processes.
- Better management of change such as promotions.
- Skilled people focused on the right things.

Additionally through delivering operational excellence, cost savings along the supply chain have been realized. The model provides a simple template for good business practice that can be used in most supply chains.

### **Conclusion**

In the modern business world, Consumers and Customers are rarely satisfied with anything less than 'The best'. For a company like Kraft Foods to provide the best brands of coffee, chocolate, cheese and many other products, it needs to make sure that every part of its Supply Chain is working at its best.

The process that Kraft Foods has designed to ensure it delivers that service excellence to its Customers and Consumers is called The Service Excellence Programme.

This case study provides the student with an excellent example of what businesses need to do in today's market place to ensure that consumers receive the products they desire in the right place, at the right time and in the right condition, every time.



## 1.8 CUSTOMER RELATIONSHIP MANAGEMENT – THEORY AND PRINCIPLES

### Introduction

Marketing is a very dynamic discipline that constantly reacts to impulses of social-economic shifts and to needs of various entrepreneurial subjects. Successful can be only those companies that actively apply marketing approach to the market. Clearly stated marketing philosophy, thorough knowledge of the market, organization subject to a marketing strategy and sufficient timing advance in decision making are absolutely necessary for a company to operate in the EU market environment. Different companies though have different prerequisites, conditions and possibilities to utilize this approach fully and effectively. One of the limiting factors is the size of a company. Important parts of economical infrastructure of developed countries are small and medium sized enterprises that have fundamental influence on their entrepreneurial environment.

Current small and medium sized enterprises take care of many different segments of local customers or even operate in the whole area of the European Union. However their customers are not willing to accept just any product, they require the best one with the highest added value. Current development of entrepreneurial environment coupled with simultaneous development of information and communication technologies even further intensify competition. That's why it is necessary for these companies to exercise modern marketing with strong emphasis on partnership with their customers and to be able to simply and centrally manage all processes, which then leads to fulfillment of their goals. That is the content of customer relationship management (further referred to as CRM).

Today growing businesses manage customer connections and information in a variety of ways. Some use old fashioned note cards and Rolodex. Others store information on their mobile phone while on the go or while having no means of accessing a Personal Computer or a laptop. Others use Excel spreadsheets or Google documents and that is the most common case. While that may help in the short term when you have a small team and don't plan on scaling up your business, if you want to scale up for fast growth, it may be time to consider a CRM system to help you collect your precious business data in one place, make it accessible via the cloud, and free up your time to focus on delighting customers rather than letting valuable insights and information fall through the cracks while you are on the go.

Once thought of as a type of software, CRM has evolved into a customer-centric philosophy that must infiltrate an entire organization. If customer relationships are the heart of business success, then the CRM is the valve that pumps a company's life blood. As such, Customer Relationship Management is best suited to help businesses use people, processes, and technology to gain insight into the behavior and value of customers. This insight allows for improved customer service, increased call center efficiency, added cross-sell and upsell opportunities, improved close rates, streamlined sales and marketing processes, improved customer profiling and targeting, reduced costs, and increased share of customer and overall profitability.

CRM acts as a central repository of information on your clients and potential clients. Customer relationship management software hones in on the relationship. Every business organization depends on customers for sustenance, the question is how to create and maintain customer satisfaction. Every business communicates with their clients in many different ways, especially in our technology rich and information based society. How we treat all of this information is where CRM plays a key role. It entails all aspects of interaction that a company has with its customer, whether it is sales or service-related.

CRM developed for a number of reasons:

- The 1980's onwards saw rapid shifts in business that changed customer power
- Supply exceeded demands for most products
- Sellers had little pricing power

- The only protection available to suppliers of goods and services was in their relationships with customers

### 1.8.1 Definition of CRM

What is Customer Relationship Management (CRM)? There are as many definitions for CRM as there are opinions as to what is going to happen in the stock market the next day. At its basic core, CRM entails initiatives that surround the customer side of the business. An example is initiatives wrapped around the customers in an effort to increase sales, improve customer service, add market share, enhance customer loyalty and reduce operating costs of sales and service. At its more formal definition, CRM is a business strategy comprised of process, organizational and technical change whereby a company seeks to better manage its enterprise around its customer behaviors. It entails acquiring and deploying knowledge about customers and using this information across the various customer touch points to increase revenue and achieve cost reduction through operational efficiencies.

The adoption of CRM is being fuelled by a recognition that long-term relationships with customers are one of the most important assets of an organisation.

It entails all aspects of interaction that a company has with its customer, whether it is sales or service-related. CRM is often thought of as a business strategy that enables businesses to:

- Understand the customer
- Retain customers through better customer experience
- Attract new customer
- Win new clients and contracts
- Increase profitably
- Decrease customer management costs

CRM is an integrated approach to identifying, acquiring and retaining customers. By enabling organizations to manage and coordinate customer interactions across multiple channels, departments, lines of business and geographies, CRM helps organizations maximize the value of every customer interaction and drive superior corporate performance.

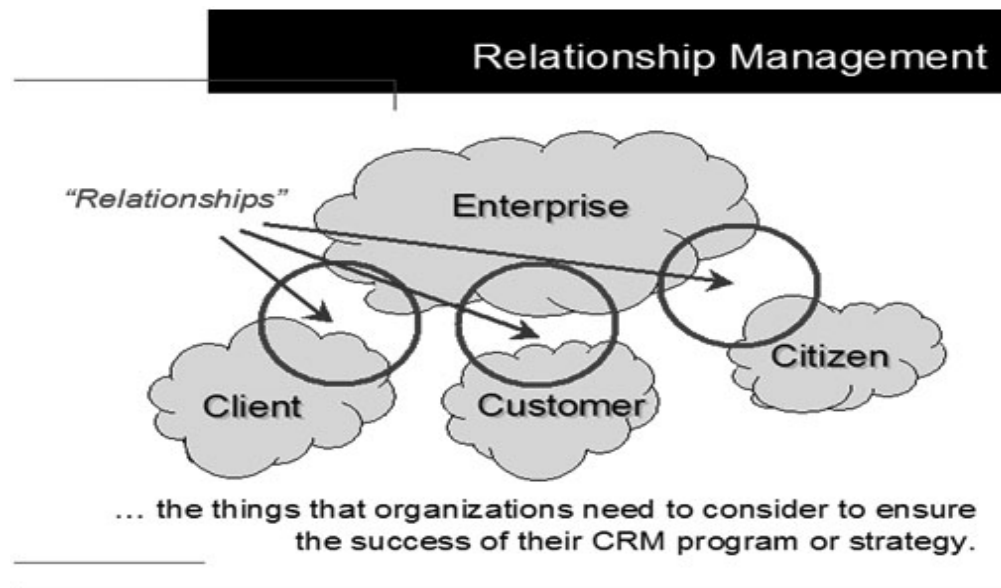

## Parts of CRM:

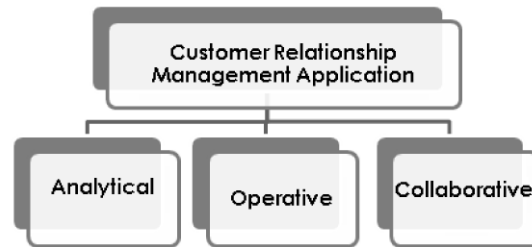

The complete description of how CRM functions in a company would be too complex, that is why authors only describe basic division into parts and their characterization. Buttle calls this “types” of CRM, but other authors incline to a view by Dohnal that describes this as three parts of CRM application architecture: analytical, operative and collaborative. In order for any action in CRM to be successful it requires consistent data about customers which will be accessible to every employee of a company. That is also highly demanding on a technology providing CRM in a company.

### Analytical CRM

The purpose of analytical CRM is customer data analysis, its evaluation, modeling and prediction of customer behaviour. In real life situation the analytical CRM can for example gather all the data about customers inquiring a specific product by using data mining (tool for data gathering), what services they purchased right away and what services they purchased eventually. It can find patterns in their behaviour and propose next steps during up-selling or cross-selling. It can evaluate efficiency of a marketing campaign, propose prices or even develop and propose new products. This way analytical CRM serves as some sort of help during decision making, e.g. manuals for employees working in services concerned with how to react to certain customer's behaviour.

### Operative CRM

Operative CRM mainly supports the actual contact with customers conducted by front office workers and general automation of business processes including sales of products, services and marketing. All communication with the customer is tracked and stored in the database and if necessary it is effectively provided to users (workers). The advantage of this approach being the possibility to communicate with various employees using various channels but creating the feeling that customer is being taken care of by just one person. It can also minimize the time that the worker has to spend typing the information and administrating (the data is shared). This allows the company to increase the efficiency of their employees work and they are then able to serve more customers.

### Collaborative CRM

Collaborative CRM enables all companies along the distribution channel, as well as all departments in a company, to work together and share information about customers, even speaks about partner relationship management (PRM). But sometimes we might see a rivalry between departments that undermines efforts of CRM to share relevant data throughout the whole company (e.g. information from help line can help the marketing department choose a point on which it will focus during the next campaign). The goal of collaborative CRM then is maximum sharing of relevant information acquired by all departments with the focus on increasing the quality of services provided to customers. The ultimate outcome of this process should be an increase in customer's utility and his loyalty .

Information technology plays an important role in the concept of CRM. Without its smooth function the modern CRM would be unimaginable. But it is not only the technology that is important. Company must be willing and able to adopt the whole philosophy which puts the main focus on the customer. It must adopt the strategy focused on establishing and supporting long-term relationship with customers. Failure in following this philosophy and strategy leads to a failure of whole CRM implementation.



An example will demonstrate the entire CRM process and its use. The basis of every CRM system is data about customers that is stored transparently by all departments in one huge data warehouse. Analytical CRM works with this data. It processes this data and automatically performs basic tasks, analyses patterns of customer's behavior and makes predictions. It transforms the data into information. The information is sent to operative component where front office workers put it into use. It allows that information to be used for efficient and personalized interaction with clients. These three steps are observed by back office workers which influence them and are influenced by them (e.g. creation of a new suitable product). Information from operative CRM is readily available to any employee through collaborative CRM. Customer sees this system as an activity geared up to him and reacts to it. This reaction then influences the whole process which thanks to this input continues to work. All this illustrates the diagram below.

**Technological aspects and principles of CRM**

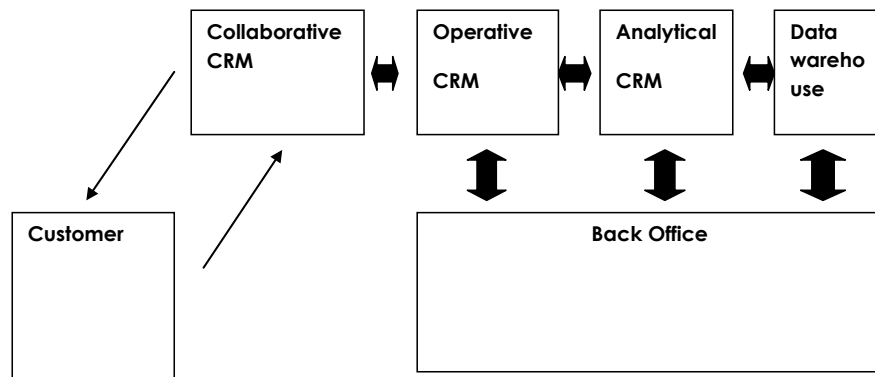

**Objectives for using CRM applications**

Objectives of using CRM Applications, defined in the following line:

- I. To support the customer services
- II. To increase the effectiveness of direct sales force.
- III. To support of business to business activities.
- IV. To support of business to consumer activities.
- V. To manage the call center.
- VI. To operate the In- bound call centre.
- VII. To operate the Out - bound call centre.
- VIII. To operate the Full automated(i.e. no CRM involvement, "lights out")

## Objectives of CRM Applications showing

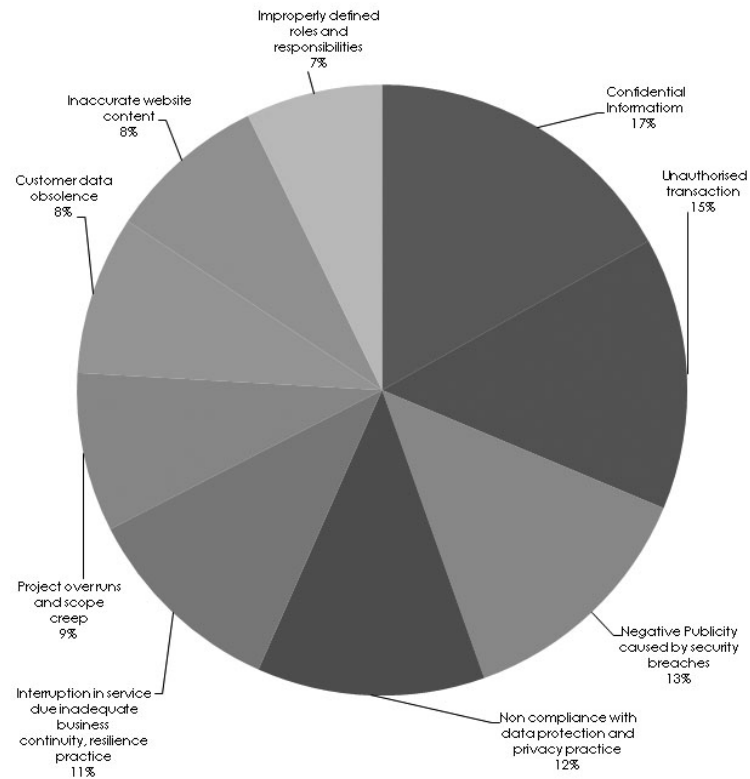

### Advantages and benefits of CRM

Certainly a benefit for each company is to achieve better economic results thanks to achieving higher value from every interaction with a customer. Competition is very sharp in current market. Companies must take care of a customer in every area of their specialization by using various communication channels. Customer expects perfect services whether he calls a help line, asks a dealer, browses a web site or personally visits a store. It is necessary to assure him in a feeling that he communicates with the same company whatever form of communication, time or place he chooses. According to Matušinská the basic advantages and benefits of CRM are these:

- satisfied customer does not consider leaving
- product development can be defined according to current customer needs
- a rapid increase in quality of products and services
- the ability to sell more products
- optimization of communication costs
- proper selection of marketing tools (communication)
- trouble-free run of business processes
- greater number of individual contacts with customers
- more time for customer
- differentiation from competition
- real time access to information

- fast and reliable predictions
- communication between marketing, sales and services
- increase in effectiveness of teamwork
- increase in staff motivation

Advantages and benefits are almost endless. Unfortunately some negatives exist. One of them is the fact that proper implementation and running of CRM is very difficult (technology, people – employees, initial money investment etc.), another one is the safety of information that companies keep about their customers, sharing information with third party and its overall protection. The entire operating principle of CRM (gathering information, recording calls, analyzing all clients' activities etc.) is invasion of privacy of customers.

For effective relationship management it is necessary for a company to not only hold onto their perspective but also try to understand why it is beneficial for a customer to establish a long term relation. Customer always cares primarily about satisfaction of his needs. If a company wants to establish mutual long-term relationship it must offer him something extra, some "reward" that will give him the desired value. The success rate of company being able to satisfy this desired value represents the quality of CRM. One hundred percent success rate is rarely achieved. However if the success rate in "rewarding" is acceptable then the customer continues in the relationship (makes further purchases).

### **Definition of CRM Risks**

An overwhelming 91 percent of the respondents indicated that risk management is either a very important (55 percent) or moderately important (36 percent) aspect to their CRM projects. Why is it so important? Look at some of the impacts that a CRM initiative may have on an organization:

- Increased expectations from senior management to increase revenues, reduce costs, increase market share and increase business flexibility may put tremendous pressure on the organization and may potentially compromise the internal control structure
- Increased complexity of managing multiple channels, technologies, customer relationships and customer definitions
- Vital and confidential customer information may be transmitted and shared across new networks, systems and platforms
- Significant changes to the organization, attitudes and beliefs, placing heavy reliance on the organization's employees for the successful adoption of the solution.

These factors introduce many risks to the organization, for instance, the potential disruption of vital operations; violations to customer privacy and confidentiality; ineffective, inconsistent or inefficient processes; lack of internal business controls; poor customer service; incorrectly targeted sales and marketing efforts, non acceptance of new systems and processes; and security breaches.

However, since CRM is still an evolving area and the type of CRM projects can vary so vastly between organizations (e.g., data mining, sales force automation, web-enabling sales, call center consolidation), there are many different definitions of CRM risks. When survey respondents were asked their definition of CRM risks, the definitions ranged from customer dissatisfaction, data corruption, privacy, legal, loss of competitive advantage and business benefits as listed in Table below.

<b>Definition of Risks Impacting a CRM Solution</b>	
<b>Customer dissatisfaction/loss of customers (27 percent)</b>	
<ul style="list-style-type: none"> <li>• “CRM risks can be very simply defined to be the risk of losing customers to competitors' better business practices and strategies and the consequent loss of customer satisfaction and relationship continuance.”</li> <li>• “Inadequate understanding of CRM and wrong system implementation will cause customer dissatisfaction.”</li> </ul>	
<b>Data integrity is compromised/security (15 percent)</b>	
<ul style="list-style-type: none"> <li>• “Customer data is mismanaged or misused in a way that corrupts data or erodes customer satisfaction or Opinion.”</li> <li>• “CRM risks are those that damage customer's privacy and confidentiality.”</li> </ul>	
<b>Inability to meet objectives/ benefits not realized (13 percent)</b>	
<ul style="list-style-type: none"> <li>• “The main risk that the implementation of the CRM may cause is the high expectation generated by the potential tool versus the actual possibility of attaining functionality.”</li> <li>• “The implemented solution does not meet the expectation and organization objectives.”</li> </ul>	
<b>Risks to the business in general (13 percent)</b>	
<ul style="list-style-type: none"> <li>• “CRM risks are risks to the business (especially in sales, service and marketing areas) in terms of financial risk, operational risk, commercial risk and profitability risk, arising from failure to adopt the right processes and technologies.”</li> <li>• “CRM risks amount to the overall operational impact that the new CRM system will bring about to the entire organization.”</li> </ul>	
<b>Events and circumstances that could affect the implementation (12 percent)</b>	
<ul style="list-style-type: none"> <li>• “Any event, action or circumstance that inhibits the achievement of the business objectives related to the Customer and his interactions with the business.”</li> <li>• “CRM risks are events or circumstances hindering the successful and/or timely completion of the CRM project.”</li> </ul>	
<b>Loss of competitive advantage (6 percent)</b>	
<ul style="list-style-type: none"> <li>• “CRM risks are risks emanating from customer service and competitive advantage of the overall goal of the organization.”</li> <li>• “The biggest CRM risk is the loss of competitive advantage.”</li> </ul>	
<b>Legal considerations (4 percent)</b>	
<ul style="list-style-type: none"> <li>• “CRM risks of an engagement could result in legal problems.”</li> <li>• “With CRM, the organization runs the risk of negative profile/impaired credibility leading to public criticism and erosion of statutory role.”</li> </ul>	
<b>Lack of controls (4 percent)</b>	
<ul style="list-style-type: none"> <li>• “The risk involves the ability to identify any control weaknesses.”</li> <li>• “The risk of reintroducing or not controlling traditional, manual-based controls for lack of incorporating appropriate controls or mitigating the risk in redefined or automated CRM processes.”</li> </ul>	

<b>Negative impact on business reputation (2 percent)</b>	
•	“These are risks that affect the reputation of the bank such as fraud or rumors from customers that can cause a run on the bank.”
•	“One risk is the negative impact on revenue and organization image.”
<b>Loss of market share (2 percent)</b>	
•	“It is the risk that poor customer service will result in loss of market share.”
•	“CRM risk is not knowing exactly the expectation levels of customers and ultimately losing market share.”
<b>Acceptance of CRM within the organization (2 percent)</b>	
•	“The risk here is the inability of the organizational structure to support the CRM system.”
•	“Acceptance of the system and added value to the business are key CRM risks.”

But regardless of the definition used to describe CRM risks, one thing is apparent: risk management is considered an important aspect of the success of CRM projects.

### Determining Risk Tolerances

Now that risk management has been established as important to organizations, which risks should be tolerated? The methods and approaches to determining the organizations' tolerance to CRM risks are as varied as the organizations themselves. When asked how they determine their risk tolerances, 32 percent of organizations indicated informal methods such as arbitrarily assigning risks a high, medium or low rating based on common sense or their intuition. Surprisingly, 22 percent of the organizations did not determine or calculate their risk tolerance. And on the other side of the spectrum, 14 percent of the organizations use statistical analysis methods. The statistical analysis methods also varied significantly, but some of the more common methods include:

- Ratio of potential losses to the potential plus actual sales revenues generated
- Grade of impact multiplied by the number of times of one action
- Risks multiplied by the costs to prevent the risks
- Cost of total risks divided by the total revenue
- Probability multiplied by impact by timescale to equal risk priority
- Multiplying a factor of the probability of the risk happening and the qualitative estimate of the damage it will cause
- Proper weighting of the qualitative impact that risks will create for the organization

Other methods for determining risk tolerances include determining the maximum acceptable financial risk, scenario analysis, customer responses/feedback and benchmarking.

Those organizations that had determined their risk tolerance were asked to identify the risks that would have the most significant impact on their organization. Most survey respondents indicated traditional risk areas such as security, trust, privacy and internal controls as illustrated in **figure below**.

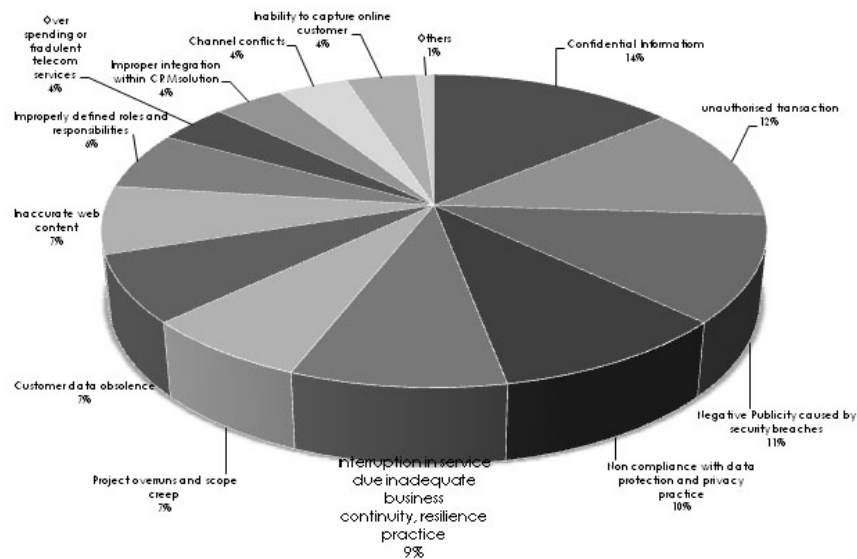

## Conclusion

Definitions of customer relationship management have gradually changed as CRM was becoming more tangible and sizeable strategic management. They evolved from the original focus on technical aspect to current orientation of the whole company on a philosophy of establishing effective long-term relationship with customers. The authors see a big analogy of this approach to the way how business has been done in past millennium. Nowadays the advanced CRM systems allow even global companies to apply the knowledge of an individual customer locally which enables them to get to him as close as possible. The progress subsequently allows small and medium enterprises to get these procedures and know-how of large companies. Thanks to this progress it should even be possible that micro companies can adapt the advantages of CRM systems. The authors perceive this as a final piece of a circle and logical coming to the system that always has had and always will work.

## Case Study

### 1. Building sound customer relationships - A Royal & Sun Alliance case study

#### Introduction

Customer service is the whole activity of identifying customer needs, satisfying them fully and keeping them satisfied. In service industries in particular, customer service is best achieved through relationship management, which involves building firm, enduring, business relationships with customers.

Royal & Sun Alliance is one of the world's major insurers, with operations in around 50 countries it carries out business in over 130 countries. The company looks to meet the needs of the brokers with which it deals and who are its direct customers. This case study shows how the company has successfully developed relationship management with its brokers using an approach called 'Energy'.

Like other service industries, insurance companies are faced by consumers whose requirements are becoming increasingly sophisticated and whose willingness to switch to another supplier is on the increase. To compete successfully and thrive in this environment, companies must be forward thinking in their approach to customers and in applying new techniques.

This case study shows how Royal & Sun Alliance has applied successful customer segmentation and relationship management to achieve successful partnerships with its key customers.

## **Segmentation**

Customer segmentation is the process of gathering information about customers, identifying distinct segments of the overall market and then developing approaches to meet the needs of these segments.

Relationship management is the process of developing one-to-one relationships with customers. In a market in which products are increasingly similar, the key to differentiating one brand from another is through customer relations.

## **Background**

Royal & Sun Alliance sells most of its commercial business through insurance brokers, who place the business with the company on behalf of their industrial and commercial customers.

Royal & Sun Alliance believes that in the long term the number of brokers will reduce. The winners of the future will be brokers who currently run successful businesses and who demonstrate vision, adaptability and innovation. Qualitative research carried out has shown that these brokers need support from insurers who are prepared to put the same amount of energy into the relationship to enable them to achieve their goals. Using this information, Royal & Sun Alliance introduced a proposition for key independent brokers that brought them service and resources to support them in winning, retaining and servicing clients. This proposition was called 'Energy'.

## **Responding to the research evidence**

In order to deliver a solution that would meet customer needs, Royal & Sun Alliance consulted a sample of its top 200 independent brokers. The results of this research revealed the key elements that brokers were looking for in a partner:

- Relationships at all levels with individuals who are empowered to make decisions
- A proposition exclusive to themselves
- Financial support to aid their strategic goals.

The proposition required that Royal & Sun Alliance should change its focus. Instead of conducting business on a highly product based, transactional and price focused level, the Energy proposition required Royal & Sun Alliance to change its approach and instead sell solutions giving added value, focusing on promoting long term relationships. The aim was to follow through a specific process to help brokers to achieve their aims by:

- Analyzing and understanding key customers' business plans
- Analyzing and understanding the organization's total relationship with these customers
- Joint planning with key customers
- Giving a total relationship, incorporating all sectors of Royal & Sun Alliance including Commercial, Life and Personal lines.

Having established these aims, it was then possible to start to build strategic partnerships with key customers and a long-term mutual outlook that enables both parties to achieve their goals.

## **Choosing the Brokers**

A vital part of building on the Royal & Sun Alliance brand was to choose the brokers best suited for joint development of the Energy proposition. Because selling insurance is so competitive, it was essential to focus on working with high quality brokers who had a positive attitude to business and innovation as



well as clear long term goals. Royal & Sun Alliance chose to work with independent brokers who could demonstrate: a loyal customer base

- A strong service ethic
- A desire for a long term strategic partnership
- Promising future prospects.

### **The Nature of Strategic Partnership**

Strategic partnerships are long term, exclusive partnerships between Royal & Sun Alliance and key brokers using the Energy proposition. They are designed to secure the future success of all partners and are based on:

- A shared vision of the future
- Common goals
- Clear understanding and commitment from everyone involved
- Mutual benefits
- Innovation and integrated solutions.

The partnership is not about offering special discount on price but about allowing brokers to gain advantages by using other benefits and resources to win and secure long term customers.

### **Energy**

The name Energy was chosen because it symbolizes the values and behaviours of Royal & Sun Alliance people and broker partners. Having selected 150 broker partners, the objective was to help them to grow their businesses and by doing so to increase Royal & Sun Alliance's share of that business. The emphasis was on customer service levels as well as providing additional first class value-added benefits. Energy works because those operating it:

- Understand each customer's unique needs
- Plan and achieve mutual goals
- Provide the tools, resources and service to achieve goals.

The Energy proposition is designed to provide a unique match to each Energy Broker. A 'relationship manager' looks after each Energy Broker to aid the understanding and analysis of the customer's needs and goals. A joint development plan is then agreed which highlights what Royal & Sun Alliance needs to deliver to support the relationship. Every plan is unique. Service levels are mutually agreed and form the basis of delivery. Previously, the relationship with customers had been focused through one individual whose responsibility was for the management of a broker account, and almost all communication, negotiations, and contact was transacted through that one person, despite the backup of sound underwriting and claims teams.

Energy required a fundamental change in the nature of the relationship between brokers and Royal & Sun Alliance. A 'relationship manager' controls the overall business plan and acts as a coordinator between different business divisions and the customer. However, on a day-to-day business the relationship is disseminated to empowered individuals who produce relationships at all levels, hence eliminating bottlenecks.

### **Benefits**

Energy provides a number of important benefits to key customers. Services include:

- training either on-line or in-house
- marketing support



- knowledge sharing e.g. IT and finance
- use of Royal & Sun Alliance facilities
- advice lines e.g. legal, financial, Health and Safety and stress counseling
- financial assistance.

Energy participants have already gained from these additional benefits.

### **E-Technology**

E-Technology has been a major driver for change in service industries. Royal & Sun Alliance therefore, created a web-site dedicated to Energy brokers. It is password protected and each broker has an individual user ID in order to gain access. The web-site, includes on-line training materials, risk management guidance, a technical library, details of consultancy available, terms of business agreements and links to other useful Royal & Sun Alliance sites. There is also a facility for sharing of information between Energy brokers. The site is regularly updated and will soon provide the facility to access claim details on-line.

### **Monitoring success**

All new business initiatives need to be monitored in order to assess performance levels and to make ongoing improvements. The key indicators used by Royal & Sun Alliance to monitor success are:

- Delivery of service standards
- Higher business retention levels
- Profitable growth on existing business
- Increased flow of new business
- Market leadership
- Customer feedback.

### **Ensuring Success**

Making sure that Energy was a success required a systematic approach using project management techniques to ensure a smooth launch and ongoing high levels of performance.

Energy brokers were carefully selected, taking into consideration both quantitative (e.g. profitability) and qualitative (eg professionalism) factors and ensuring they are 'winners of the future'. Training of key development staff was important - participants developed skills in relationship management and business planning. Clear communication channels were created to all staff and brokers at all levels.

An Energy Business Manager was appointed to ensure a consistent approach throughout the UK. Finally, constant monitoring of the performance of Energy brokers provides a form of quality control, making it possible to promote new brokers and, if necessary, to relegate brokers, where the relationship is not working.

Energy required Royal & Sun Alliance to re-organize its business and implement a fundamental change in approach in terms of customer segmentation and customer relationship management. It has helped the business to focus on the relationship between insurer, broker and client with a view to providing solutions to the increasingly varied business needs of customers. The proposition is as individual as the relationship with each broker. In the present market, service delivery forms a vital element and is a key differentiator between suppliers. By helping brokers to grow their business, Royal & Sun Alliance is sharing in their long term success.

Energy has already delivered clear positive results for both brokers and Royal & Sun Alliance. A regular programme of Energy broker feedback allows Royal & Sun Alliance to constantly review and update improvements to the relationship.



## 2. TESCO - The Customer Relationship Management Champion

### Introduction

The case describes the customer relationship management (CRM) initiatives undertaken by Tesco, the number one retailing company in the United Kingdom (UK), since the mid-1990s. The company's growth and its numerous customer service efforts are discussed. The case then studies the loyalty card scheme launched by the company in 1995.

It examines how the data generated through this scheme was used to modify the company's marketing strategies and explores the role played by the scheme in making Tesco the market leader. The case also takes a look at the various other ways in which Tesco tried to offer its customers the best possible service.

Finally, the company's future prospects are commented on in light of changing market dynamics, the company's new strategic game plan, and criticism of loyalty card schemes.

### Issues

Examine how the information gathered through CRM tools can be used to modify marketing strategies and the benefits that can be reaped through them.

### A Master at CRM

Every three months, millions of people in the United Kingdom (UK) receive a magazine from the country's number one retailing company, Tesco. Nothing exceptional about the concept - almost all leading retailing companies across the world send out mailers/magazines to their customers.

These initiatives promote the store's products, introduce promotional schemes and contain discount coupons. However, what set Tesco apart from such run-of-the-mill initiatives was the fact that it mass-customized these magazines. Every magazine had a unique combination of articles, advertisements related to Tesco's offerings, and third-party advertisements.

Tesco ensured that all its customers received magazines that contained material suited to their lifestyles. The company had worked out a mechanism for determining the advertisements and promotional coupons that would go in each of the over 150,000 variants of the magazine. This had been made possible by its world-renowned customer relationship management (CRM) strategy framework.

The loyalty card scheme (launched in 1995) laid the foundations of a CRM framework that made Tesco post growth figures in an industry that had been stagnating for a long time.

The data collected through these cards formed the basis for formulating strategies that offered customers personalized services in a cost-effective manner.

Each and every one of the over 8 million transactions made every week at the company's stores was individually linked to customer-profile information.

And each of these transactions had the potential to be used for modifying the company's strategies. According to Tesco sources, the company's CRM initiative was not limited to the loyalty card scheme; it was more of a companywide philosophy.

Industry observers felt that Tesco's CRM initiatives enabled it to develop highly focused marketing strategies.

### Background Note

The Tesco story dates back to 1919 when Jack Cohen (Cohen), an ex-army man, set up a grocery business in London's East End. In 1924, Cohen purchased a shipment of tea from a company named T E Stockwell.

He used the first three letters of this company's name, added the 'Co' from his name and branded the tea 'Tesco.'

Reportedly, he was so enamored of the name that he named his entire business co. The first store under the Tesco name was opened in 1929 in Burnt Oak, Edgware.

### **CRM - The Tesco Way**

Tesco's efforts towards offering better services to its customers and meeting their needs can be traced back to the days when it positioned itself as a company that offered good quality products at extremely competitive prices.

### **Reaping the Benefits**

Commenting on the way the data generated was used; sources at Dunhumby said that the data allowed Tesco to target individual customers, instead of targeting them as a group.

Since the customers received coupons that matched their buying patterns, over 20% of Tesco's coupons were redeemed - as against the industry average of 0.5%.

The number of loyal customers increased manifold since the loyalty card scheme was launched.

### **From Customer Service to Customer Delight**

To sustain the growth achieved through the launch of Club cards, Tesco decided to adopt a four pronged approach: launch better, bigger stores on a frequent basis; offer competitive prices (e.g. offering everyday low prices in the staples business); increase the number of products offered in the Value range; and focus on remote shopping services (this included the online shopping venture). To make sure that its prices were the lowest among all retailers, Tesco employed a dedicated team of employees, called 'price checkers.' An Invincible Company? Not Exactly

Tesco's customer base and the frequency with which each customer visited its stores had increased significantly over the years. However, according to reports, the average purchase per visit had not gone up as much as it would have liked to see.

Analysts said that this was not a very positive sign. They also said that while it was true that Tesco was the market leader by a wide margin, it was also true that Asda and Morrison were growing rapidly. Given the fact that the company was moving away from its core business within UK (thrust on non-food, utility services, online travel services) and was globalizing rapidly (reportedly, it was exploring the possibilities of entering China and Japan), industry observers were rather skeptical of its ability to maintain the growth it had been posting since the late-1900s. The Economist stated that the UK retailing industry seemed to have become saturated and that Tesco's growth could be sustained only if it ventured overseas.

### **1.8.2. CUSTOMER PROFITABILITY**

In Charlotte, North Carolina, the customer service centre of First Union Corporation, the sixth largest bank in the US, handles 45 million calls per year. The centre's computer system, 'Einstein', determines the ranking of a customer profitable or unprofitable – in 15 seconds. Customers are assessed with respect to minimum balance, account activity, branch visits, and other variables. At the service desk the computer screen displays a colour red, green, or yellow to signify the customer's profitability rating. Thus, when a customer requests a lower credit card interest rate or a waiver of account service fees, the service representative is able to respond quickly according to the customers' rating.

Over the last 10 years, strategic cost management and activity-based costing (ABC) have created a framework for companies to examine more closely the drivers (or causes) of their costs in order to improve management decisions and corporate profitability. Companies initially focused on product profitability are now using ABC and other models to examine further the profitability of distribution channels and customers.

Simultaneously, many companies are exploring the drivers of profit and success through the use of the balanced scorecard. Whichever model is used initially, determining customer profitability requires a clearer understanding of the causes of the revenues and the costs. This guideline provides details of



company experiences in examining the causal relationships between the drivers of customer satisfaction and customer revenues as well as in measuring the profitability and costs of servicing existing customers.

Expanding global competition is one reason behind the increased concern for customer profitability. Companies worldwide are being pressured to become more customer focused and to increase shareholder value. Customer profitability analysis is a useful tool in both areas.

### **Increasing customer Focus**

Many companies are convinced that improving corporate profitability requires more customer contact and closer customer relationships. Further, many marketing professionals have directed recent attention to increasing customer satisfaction, primarily examining the links between overall satisfaction and revenues. Meanwhile, accountants have traditionally focused on cost reduction. Customer profitability analysis attempts to bring together marketing and accounting professionals to analyze, manage, and improve customer profitability.

Companies are attempting to understand better and to satisfy present and future customer demands. However, the goal is to increase customer satisfaction profitably. The analysis presented here, relying on ABC and other tools, can direct managerial attention to areas of improvement that can lead to greater customer and corporate profits. An ABC system is not the only means to measure customer profitability, but merely one of several tools that can be used.

Since ABC provides a better understanding of the profitability of products and services, companies have started to use the same approach to understand the profitability of customers. Following an ABC analysis, companies can examine the customer profitability information and determine how to manage customer relationships in order to increase customer satisfaction and the profitability of both individual customers and customer segments. The ABC analysis often provides information leading to such improved relationships that the profitability of both the company and its customers is increased.

Companies have been using improved information technology and large databases to help refine marketing efforts. Marketing tools and IT systems now permit companies to target individual customers and customer groups with pinpoint accuracy and to determine whether or not a customer spends enough to warrant the marketing effort. For example, at Federal Express, customers who spend a lot of money but demand little customer service and marketing investment are treated differently than those who spend just as much but cost more to maintain. In addition, the company no longer markets aggressively to those customers who spend little and show few signs of spending more in the future. This change in strategy has substantially reduced costs.

### **Increasing shareholder value**

As the interest in increasing customer satisfaction has grown, so has the interest in increasing shareholder value. Companies are competing globally not only for customers, labourers, and suppliers, but also for capital. This has caused companies to concentrate on satisfying investors and lenders through an increase in shareholder value.

### **Essential components of improved customer profitability include:**

- the analysis of the cost of customer service through ABC;
- the measurement of the lifetime value of a customer; and
- the development of long-term customer relationships for increased revenues and profits.

An important challenge for companies is to manage customer relationships in order to make each customer profitable. Bank of America calculates its profits every month on each of its more than 75 million accounts; this permits the company to focus on the 10% of its customers that are the most profitable. Since it launched the program in 1997, customer defections are down and account balances in the top 10% have grown measurably. Calls from preferred and unprofitable customers are routed to different operators. A personal identification number entered by each caller allows the bank to determine,

among other things, the customer's profitability ranking. The level of attention and service will then differ accordingly. Bank of America still values customer service, but also understands that there must be a balance between customer service and customer profitability.

**Customer satisfaction, loyalty, and value**

Recently, many companies have looked to the service profit chain model (see Figure below) to help them understand the causal relationships between employees and customers and the impact on revenue growth and firm profitability. Among the relationships that have been documented and measured in this model are:

- Customer satisfaction and loyalty;
- The value of services and goods delivered to customers;
- Employee satisfaction, loyalty, and productivity;
- Employee capabilities that aid in delivering outstanding results to customers.

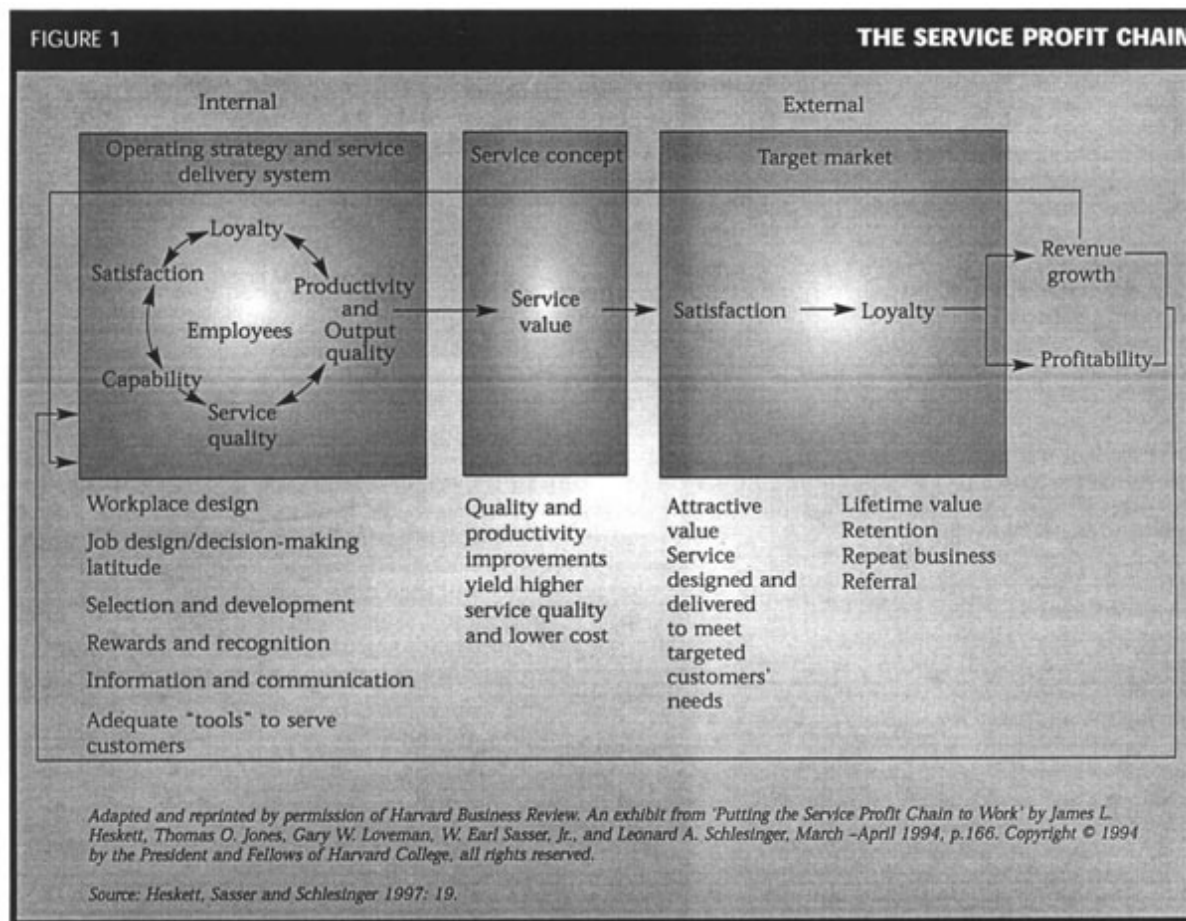

**Analyzing Customer Profitability**

Typically traditional cost accounting is not able to identify product and service costs or distribution and delivery costs for individual customers. ABC can help identify customer activities and track those costs that are allocated to specific customers. This can provide management with unique information about customers and customer segments. The benefit includes:

- protecting existing highly profitable customers;

- reprising expensive services, based on cost-to-serve;
- discounting to gain business with low cost- to-serve customers;
- negotiating win-win relationships that lower service costs to co-operative customers;
- conceding permanent loss customers to competitors; and
- attempting to capture high-profit customers from competitors.

Customer profitability analysis has become an important new management accounting tool based on recognition that each customer is different and that each dollar/pound of revenue does not contribute equally to the firm's profitability. Customers utilize company resources differently; thus customer costs vary from one customer to another. The following issues should be considered when analyzing customer profitability:

- How to develop reliable customer revenue and customer cost information;
- How to recognize future downstream costs of customers;
- How to incorporate a multi-period horizon in the analysis; and
- How to recognize different drivers of customer costs.

This requires a broader examination of the costs associated with customer service. For example, post-sale customer service costs must be included in any analysis of customer costs. Some customers require substantially more post-sale service than others. In addition, future environmental liabilities related to the sales of current products are additional downstream costs that must be included. With management's increased focus on customers, this analysis can provide forward- looking information about individual customers and customer segments and more broadly examine both the revenues and

Costs related to customer transactions. Revenues can vary among customers due to variations in volume levels, and differences in price structures, products and services.

Costs can also vary depending on how customers use the company's resources such as marketing, distribution, and customer service. Unless a complete analysis of the benefits and costs of customer relationships is undertaken, companies will unknowingly continue to service unprofitable customers. Only after a thorough analysis of the costs and benefits

Can a firm decide which customers to service and strategically price its products and services.

There are many costs that are often hidden within the production, support, marketing, and general administrative areas. To better understand customer profitability these costs should be examined and assigned appropriately using ABC methods. These currently hidden customer costs may include items such as:

- Inventory carrying costs;
- Stocking and handling costs;
- Quality control and inspection costs;
- Customer order processing;
- Order picking and order fulfillment;
- Billing, collection and payment processing costs;
- Accounts receivable and carrying costs;
- Customer service costs;
- Wholesale service and quality assurance costs; and
- Selling and marketing costs.

An example is given following:

1. Information on four customer using same products:					
Sl. No.	Particulars	A	B	C	D
a.	No. of units sold	60,000	80,000	1,00,000	70,000
b.	Selling price net(₹)	2	3	1	2
c.	No. of sales visits	3	3	5	10
d.	No. of purchase order	20	60	50	40
e.	No. of deliveries	12	16	25	15
f.	Kilometers per journey	20	35	10	50
g.	No. of rush deliveries	-	3	1	2
2. Costs of each activity (₹):					
h.	Sales Visit		2,100		Per visit
i.	Order Placing		600		Per order
j.	Product Handling		0.3		Per item
k.	Normal delivery Cost		20		Per kilometer
l.	Rushed Delivery Cost		2,000		Per delivery

**Solution:**

**Statement showing the customer profitability**

Particulars	Computation	A	B	C	D
Revenue net of discount	(a*b)	1,20,000	2,40,000	1,00,000	1,40,000
<b>Less: Costs:</b>					
Sales Visits	(c*h)	6,300	6,300	10,500	21,000
Order Processing	(d*i)	12,000	36,000	30,000	24,000
Product Handling	(a*j)	18,000	24,000	30,000	21,000
Delivery	(e*f*k)	4,800	11,200	5,000	15,000
Rush Delivery	(g*l)	-	6,000	2,000	4,000
<b>Operating Profit</b>		78,900	1,56,500	22,500	55,000
	<b>Operating Profit/ Net Revenue</b>	66%	65%	23%	39%

From the above computation we get that C and D are less profitable than A and B. Such an analysis may show the Pareto curve effect, i.e. , 20% of customer provide 80% of the profit. This 80:20 rule, first observed by Vilfredo Pareto, may vary, say 70:30 for different firms, and for different items like stock holding , costs, cost drivers in Overhead cost.

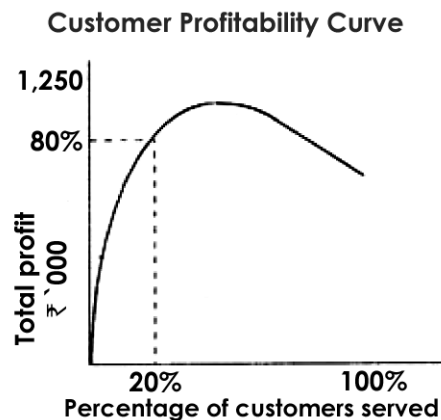

The curve shows that the last 80% of customers do not all generate profit. The last 50% actually reduce the total Profit. There is no point in serving these customers as the situation stands, but it may be foolish just to refuse to serve them. Instead, it may be better to turn them into profitable customers if this is possible, e.g. introducing a third party wholesaler into the supply chain which might result in the improvement of the product range and service to the small customers who were not so profitable to the firm.

### Case Study

#### Customer profitability analysis in a manufacturing company:

The Kanthal case provides an excellent example of how ABC can improve the measurement and management of customer profitability. Kanthal, the largest division of Swedish manufacturer Kanthal-Hoganas, had sales in excess of \$50 million per year. Most sales, about 95%, were exports from Sweden. Kanthal manufactured and sold heating

alloys for electric resistance heating elements, heating elements for industrial furnaces and thermo-bimetals for temperature control devices. The company was organized into three divisions, two of which held substantial global market shares in their particular products and the other had developed a fully integrated manufacturing system to produce the thermo bimetals.

The president of the company, Carl-Erik Ridderstale, saw the need for a strategic plan to increase profits while maintaining an annual return on employed capital in excess of 20% (Kaplan 1989:2). His 'Kanthal 90 Strategy' detailed profit objectives by division, product line, and market share. Ridderstale's plan was to achieve this growth without the need for additional sales or administrative staff to handle the expected increase in sales volume.

Ridderstale was also concerned that selling and administrative expenses formed the largest cost category in the company and were growing. They accounted for 34% of total expenses and were treated as period costs rather than allocated to either products or customers. Ridderstale wanted a new costing system that could determine how much profit was earned every time an order was placed. He also wanted to find the hidden profits and hidden costs in each order. Further, he believed that Kanthal had low profit and high profit customers depending on the demands that the customer placed on the administrative and sales staff and that these customers should be readily identifiable.

Kanthal had about 10,000 customers and produced over 15,000 items. It stocked 20% of those (3,000 items) which represented 80% of the company's sales. After assigning costs to customer orders, it became apparent that the sales of stocked items were significantly more profitable than the processing and manufacturing of non-stocked items. Since the existing system did not differentiate between orders for stocked and non-stocked items the difference in profitability had not been apparent. The cost to produce non-stocked items was greater than the costs to produce stocked items since special scheduling was required for the purchase of the raw materials and the production process. It was also more costly to produce the items in small quantities.



With the aid of consultants, the financial manager of Kanthal, Per O. Ehrling, developed an account management system to analyze production, sales, and administration costs using ABC. Two new cost drivers were added to the analysis: the additional cost of producing non-stocked items, and, the normal expense associated with any customer order such as pricing, scheduling delivery, invoicing, and collecting.

The company then accumulated, for each customer, the profit and loss figures from each individual order placed by that customer (see Figure 10 below). The results of the ABC analysis showed that while gross margins for different customers may be the same, the additional costs to produce special small orders and to fill stocked items on small orders significantly reduced the profitability of these customers. Kanthal now realized that it had a few extremely profitable

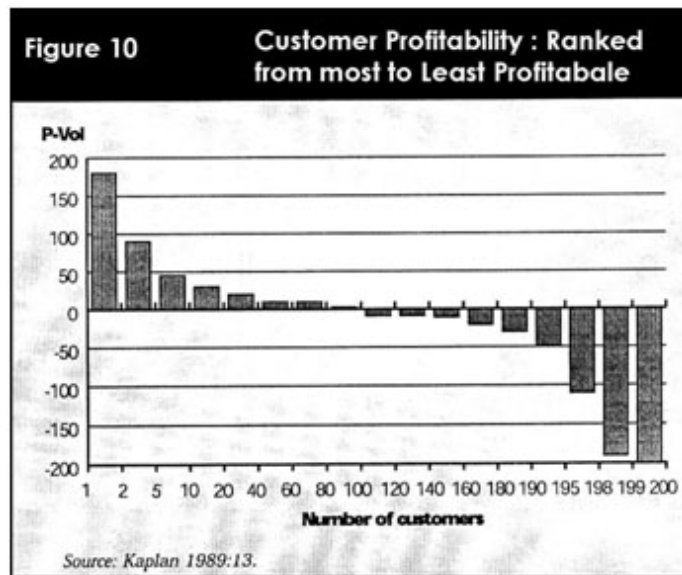

**Figure 11 Customer Order Analysis**

Country Customer	Order Lines	Invoiced Value (SEK)	Volume Cost (SEK)	Order Cost (SEK)	Non-Stocked (SEK)	Operating Profit (SEK)	Profit Margin
<b>Sweden</b>							
S001	1	1,210	543	572	0	95	8%
S002	3	46,184	10,080	1,716	4,524	29,864	65
S003	8	51,102	50,567	4,576	12,064	(16,105)	-32
S004	9	98,880	60,785	5,148	13,572	19,375	20
S005	1	3,150	1,557	572	2,340	(1,319)	-42
S006	5	24,104	14,889	2,860	4,680	1,675	7
S007	2	4,860	2,657	1,144	4,680	(3,621)	-75
S008	1	2,705	1,194	572	0	939	35
S009	1	518	233	572	0	(287)	-55
S010	8	67,958	51,953	4,576	12,064	(635)	-1
S011	2	4,105	1,471	1,144	0	1,490	36
S012	8	87,865	57,581	4,576	12,064	13,644	16
S013	1	1,274	641	572	2,340	(2,279)	-179
S014	2	1,813	784	1,144	0	(115)	-6
S015	2	37,060	15,974	1,144	3,016	16,926	46
S016	2	6,500	6,432	1,144	3,016	(4,092)	-63

Note: All financial data reported in Swedish kroner (SEK).  
Source: Kaplan 1989:11.

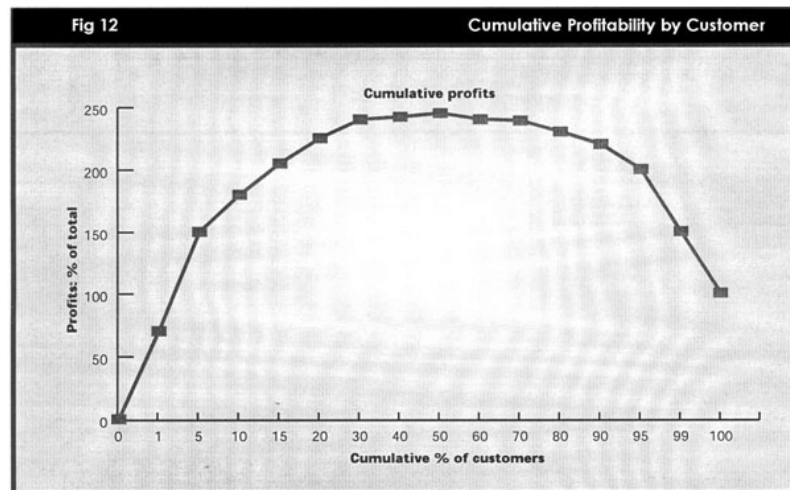

customers and a few extremely unprofitable ones (Kaplan and Cooper 1998: 185) and was surprised by the wide variation in customer profitability. Figure 10 graphically portrays select Kanthal customers and how they add or detract from profitability. Generally, the first few customer sales vs. cost of sales contributed the most profit, while the last few customers generated the largest losses due to high selling or post-sale costs.

Even more surprising to Kanthal was that some of the customers with the most sales were the most unprofitable. Two very unprofitable customers were in the top three in terms of sales volume. One of these unprofitable high volume customers had moved to just-in-time (JIT) ordering from its suppliers, placing orders weekly and sometimes twice a week. Variations in the profit margins on individual orders ranged from -179% to +65% as shown in Figure 11 (opposite).

The company also discovered that 40% of the Swedish customers generated 250% of

the profits. Finally, it also discovered that the most profitable 5% of the customers generated 150% of the profits. This was a shocking discovery as it had been thought that most customers contributed to profit. This phenomenon of a few customers being the most profitable is present in many companies.

Traditional cost accounting often supports a 20-80 rule that 20% of the largest customers, who purchase the most products, contribute 80% of the profits. Using ABC, analysts have often found that 20% of the customers generate 300% of the profits. The remaining 80% of the customers are actually unprofitable and can result in a loss of 200% of the profits. When plotted on a graph, (see Figure 12 opposite), the 'hump' of this 'whale curve' indicates the profit earned by the company's most profitable customers. The remaining customers are break-even or unprofitable and bring the overall profit back down to 100%. The goal is to make each customer profitable.

With a new understanding of which customers were profitable and which were not, Kanthal became dedicated to turning unprofitable customers into profitable ones. The company developed ways to retain the customers and decrease their administrative and selling costs (Kaplan and Cooper 1998: 188). In the short term, Kanthal tried the following: reduce the size of its product lines, accept orders only for stocked items, use external distributors to reduce the cost of small accounts, change compensation to salesmen to emphasize profit rather than only sales volume, and engineer to reduce set-up times and improves operational efficiencies.

In the longer term, the following are some of the actions taken as a result of the new ABC system:

- Involvement of salespersons was increased in discussions with management and customers;
- Prices were increased for small customized Orders;

- Product managers were encouraged to reduce proliferation of sizes and variance in product line;
- Salespersons emphasized standard products; and
- Customers were persuaded to make larger orders of stocked items.

With one particular customer, customer 200 (see *Figure 10 on page 19*), Kanthal devised an excellent solution that would make the company profitable and satisfy the customer. The company went to the customer, shared the ABC analysis, and explained the implications for profitability of producing only small orders of non-stocked items. Kanthal offered a new pricing structure that granted the customer a 10% discount on high volume orders of stocked products and charged a 60% price premium for small orders of non-stocked items. The results of this new pricing structure were reviewed one year later; Kanthal found that customer #200 gave the company the same volume of business but placed for profitability of producing only small orders of non-stocked items. Kanthal offered a new pricing structure that granted the customer a 10% discount on high volume orders of stocked products and charged a 60% price premium for small orders of non-stocked items. The results of this new pricing structure were reviewed one year later; Kanthal found that customer 200 gave the company the same volume of business but placed Orders half as many times per year, and for half as many different products. Customer 200 changed from the most unprofitable customer into one of the most profitable in the course of one year (Kaplan and Cooper 1998:188).

Kanthal's approach was to work with its customers for the benefit of both the firm and the customer. The company provided some customers with computer terminals directly linked to the Kanthal office so the customers could order directly without any sales effort being employed. Another customer, who had placed several small orders for many different types of products, was converted to a distributor. Kanthal sold larger quantities to the customer that stocked the items for its own use.

Some of the products and resold them to other small companies. Thus Kanthal was thus able to reduce its service costs to this one customer and better service other small companies.

In these instances, Kanthal discovered, like many other companies, that rapid improvements in information technology could simultaneously provide substantial benefits to both customer service and customer profitability. Further, companies have recognized that customer behavior, satisfaction, and profitability can all be increased when this new information on customer profitability is shared directly with the customer.

The ability to determine customer profitability on an individual basis can add value to the company customer relationship. As in the case of Kanthal, the customer can be helped to reduce its costs and the company can become more profitable. Increasingly with ABC, management of activities is the focus cost accounting becomes more about managing costs (rather than cost accumulation), knowing what causes costs to occur, and making changes to reduce expenditures. Kanthal was able to work with its existing customers for their mutual benefit.

Using customer profitability analysis to determine the causes of costs and then making changes to reduce those costs are important lessons to be learned from the Kanthal case. Customer profitability can only be increased by reducing costs or raising revenues. Ways to increase that profitability through better management of customer costs are facilitated by improved cost analysis. In this case, an ABC analysis was critical. The managers were unwilling to take any action until they were presented with the data that indicated the profitability of products and customers.

### **Customer profitability analysis in a service company**

The Co-operative Bank was founded in England in 1872 as a department in a cooperative wholesale society, which was the central organization formed by co-operative societies throughout the country. Co-operative societies were formed to aid working class people in obtaining goods and services at lower costs through trade and co-operation. The bank's main function was to serve the banking needs of the wholesale cooperatives and thus had few personal accounts. It expanded to serve many of the upcoming and growing cooperative societies around the country.



In 1971, an Act of Parliament established the bank as a separate legal entity. The cooperative movement had declined along with deposit and loan accounts due to competitive pressure from private businesses. Reorganized, the bank began to aggressively pursue deposits from personal customers and by the 1990s had deposits of approximately £3 billion. As the bank grew, it also broadened the range of products and services for personal and corporate customers. Increased competition from other banks and customer demand led to new products being introduced including credit cards, high-interest bearing current accounts, ATM cards, telephone banking and independent financial advice.

Under new management, the Co-operative Bank issued both a mission statement and a statement of ethical policy. These documents declared the bank's responsibility to its customers, its employees and its communities, and promoted the co-operative values

established at the founding of the bank in 1872. In the early 1990s, Co-operative Bank found itself in the midst of an economic recession and was forced to make changes to its operations in order to be more competitive and efficient. It consolidated some operations and reduced employment through voluntary retirement. However, it also increased its cross-selling activities to existing customers and began to offer a much wider choice of products. While the bank believed it had an array of excellent products and services for its customers, its cost-to-income ratio was higher than its competition. Traditional responsibility accounting was being used to measure expenses for geographic and departmental cost centres but the bank was unable to track costs to customers or to products.

In 1993, the Co-operative Bank began an ambitious project to improve its profitability and customer service. The goal of the new 'Project Sabre' was to improve the cost-to-income ratio and the service to customers. In order to accomplish this, the bank needed additional information for making changes that related to five corporate needs:

- Overhead reduction;
- Re-engineering of business processes, particularly those that did not add value to customers;
- Product profitability;
- Customer profitability; and
- Segment profitability (Datar and Kaplan, 1995:5).

The bank began an ambitious project of implementing ABC. It identified 210 cost pools and 235 activities/tasks. The bank then asked employees from different areas of the bank to match resource costs to the activities by identifying the amount of time that they spent on various activities. A sample of the activities, cost drivers, quantities, and rates are displayed in Figure 13 (below).

FIGURE 13

**PERSONAL SECTOR PRODUCTS: ACTIVITY COST DRIVERS QUANTITIES AND RATES\***

Activity description	Activity cost driver	Total activity cost	Quantity of activity cost driver	Cost per unit of activity cost driver
Provide ATM service	ATM transactions	£ 490,302	1,021,963	£0.48
Clear debit items	Number of debits processed	1,022,140	5,110,299	0.20
Branch operations for debit items	Number of branch counter debits	684,100	762,111	0.90
Issues personal cheque book	Number of books issued	263,949	40,628	6.50
Clear credit items	Number of credits processed	218,001	871,004	0.25
Branch operations for credit items	Number of branch counter credits	548,168	512,986	1.07
Lending control and security	Number of interventions	1,380,763	765,591	1.80
Customer inquiries	Number of telephone minutes	1,298,801	7,205,560	0.18
Customer correspondence	Number of customer letters	726,206	221,204	3.28
Marketing and sales activity	Number of accounts opened	2,562,046	62,120	41.24
Computer processing	Number of computer transactions (electronic impulses)	1,641,247	16,112,471	0.10
Statementing and postage	Number of statements issued	477,200	1,724,285	0.28
Advise on investments and insurance	Hours of advice given	1,159,943	32,956	35.20
Process VISA transactions	Number of VISA transactions	1,174,207	5,125,248	0.23
Issue VISA statements	Number of VISA statements issued	443,107	1,714,258	0.26
Open/maintain handyloans	Number of handyloan accounts	846,806	201,521	4.20
Open and close accounts	Number of accounts opened/closed	493,599	57,951	8.52
Administer mortgages	Number of mortgages	196,082	18,609	10.54
		<u>£15,626,667</u>		

\*Numbers disguised to maintain confidentiality.

The total costs of each activity were determined by combining all of the resource pool costs assigned to each activity. The costs of each activity were then traced to the various bank products by defining activity cost drivers for each activity. The activity cost driver represented the event that triggered the performance of each activity, such as a deposit that was processed or an account that was opened. The bank was then able to distribute the activity costs to various bank products. Some banking expenses, sustaining costs representing 15% of the total costs, were not allocated to activities or bank products. These costs were spread over the entire product and customer service range of activities. An analysis of product profitability was one of the results, as set out in the above figure .

The profitability analysis provided the bank with vital information to make decisions about product offerings, strategy and future growth. The analysis showed that the Independent Financial Advice/ Insurance product considered by the bank to be a highly profitable business was actually losing money. Current Account Plus, the basic core product of the bank, was not profitable. The bank now had a wealth of information about the cost of each activity (the cost to process cheques and credit card transactions, open and close accounts) and with this information the bank could reassess its product and service offerings. The bank realized that it had the highest cost-to- income ratio of UK banks and had to cut its costs and services in order to survive. A weakness of the product profitability analysis was that it ignored the cross-selling opportunities of the different products that the bank offered. For example, the Independent Financial Advice/Insurance product while unprofitable may be attractive to wealthy account holders, help to retain those customers and ultimately increase their lifetime profitability.

The initial analysis was limited to product profitability and the bank's team wanted to extend the ABC analysis to customer profitability by examining individual customers with current accounts. Specific assumptions were made in the allocation of the costs of the customer accounts. The team allocated



55% of current account expenses to transaction costs and 45% to account maintenance. Customers were segmented into low, medium and high based on the turnover of funds in their accounts in order to allocate the transaction costs. On the revenue side, the bank determined the income earned from the balances and fees for individual customers. By matching income with the allocated costs, managers were now able to estimate the profitability of each customer. This revealed that up to half of all current accounts, particularly those with low balances, were unprofitable.

In service organizations such as Co-operative Bank, costs are usually committed far in advance. Thus there is little incremental cost or savings from reducing or increasing customer service or activity. Each customer uses each bank product differently, so it is important to have substantial customer analysis information. For a chequing account, some customers write a lot of cheques and some do not; some customers maintain high balances and some maintain only minimal balances.

Once the information on product and customer profitability is obtained, what should management do with it? The bank devised new strategies for profitability such as:

- cross-sell more profitable products;
- distinguish between new customer and mature accounts;
- switch unprofitable customers to ATM transactions;
- set pricing for minimum balances, ATM fees, and overdrafts; and
- outsource ATM network, computer operations and cheque clearing.

The Co-operative Bank used ABC to better understand the costs of its wide range of products and its diverse customers. Prior to the ABC implementation, bank management was unable to agree on which were the profitable and unprofitable products and customers. The information from both the product profitability analysis and the customer profitability analysis for individual customers and customer groups was essential to improving customer and corporate profitability.

### 1.8.3 Customer Intelligence

Customer intelligence (CI) is information derived from customer data that an organization collects from both internal and external sources. The purpose of CI is to understand customer motivations better in order to drive future growth. The application of business analytics to customer data is sometimes called customer data mining.

Internal customer data can be generated by any customer interaction and is typically stored in corporate databases in management systems, call center systems and sales systems. Data external to the organization can be gathered from many different sources. External data typically falls into one of three categories:

- Personal demographics, which include data such as age, income level, debt level, educational profile and marital status. Such data might be analyzed to explore buying patterns of people in specific income brackets, changes in sales as people age, or sales comparisons of homeowners and renters.
- Geographic demographics, which include data aggregated from specific locations. Such data might be analyzed to explore buying patterns in rural areas, for example, or areas where most residents are young professionals.
- Attitudinal data, which includes any information about how a customer -- or potential customer -- perceives a company. Such data might be gathered from surveys, contact centers or even comments about a product or service on Twitter.

**Customer intelligence (CI)** is the process of gathering and analyzing information regarding customers; their details and their activities, in order to build deeper and more effective customer relationships and improve strategic decision making.

## CI and CRM

Customer Intelligence is a key component of effective customer relationship management (CRM), and when effectively implemented it is a rich source of insight into the behaviour and experience of a company's customer base.

As an example, some customers walk into a store and walk out without buying anything. Information about these customers/prospects (or their visits), may not exist in a traditional CRM system, as no sales are entered on the store cash register. Although no commercial transaction took place, knowing *why* customers leave the store (perhaps by asking them, or the store person, to complete a survey) and using this data to make inferences about customer behaviour, is an example of CI.

### Process

Customer Intelligence begins with reference data – basic key facts about the customer, such as their geographic location.

This data is then supplemented with transactional data – reports of customer activity. This can be commercial information (for example purchase history from sales and order processing), interactions from service contacts over the phone and via e-mail.

A further subjective dimension can be added, in the form of customer satisfaction surveys or agent data.

Finally, a company can use competitor insight and mystery shopping to get a better view of how their service benchmarks in the market.

By mining this data, and placing it in context with wider information about competitors, conditions in the industry, and general trends, information can be obtained about customers' existing and future needs, how they reach decisions, and predictions made about their future behavior.

### Example sources of data for CI

**Speech analytics** – used to monitor telephone conversations taking place between companies and customers, using phonetic analysis or speech to text to find keywords and phrases, classify call types and identify trends.

**Click Tracking** – used to monitor the popularity and usage of corporate web sites, this data can provide clues to product interest and buying intention. For example, a company may infer a customer is interested in purchasing a particular service if they are spending time browsing specific product pages.

**Customer Relationship Management** – software solutions used for **Sales force automation** and to manage customer relationships which can store data on the quantity, type and category of customer and prospect contacts.

Frontline data capture which may (or may not) form part of a CRM software solution, but which is used by front line agents to record more subjective data regarding customer contacts, such as the **root cause** of the customer picking up the phone (e.g. they received their bill) or their emotional state.

Customer satisfaction and market research surveys, often mined via **text analytics**, which can additionally be applied, for customer intelligence purposes, to contact center notes, e-mail, and other textual sources.

### Benefits

Customer Intelligence provides a detailed understanding of the experience customers have in interacting with a company, and allows predictions to be made regarding reasons behind customer behaviors.

This knowledge can then be applied to support more effective and strategic decision making – for example, understanding why customers call makes it easier to predict (and plan to reduce) call volumes in a **contact centre**.



## CASE STUDY

### Vodafone Improves Customer Acquisition and Retention with Accelerated Intelligence

#### Overview

The UK mobile telecommunications market is one of the most competitive in the world and, as a consequence, customer attrition - or 'churn' - is high. In 2005, as part of a strategy to build on its market leadership, Vodafone UK began the quest for a competitor intelligence tool that would help its sales advisors reduce customer attrition and secure new sales.

Vodafone wanted a service that would deliver timely, accurate information on the tariffs, deals and handsets being offered by its competitors to the employees that need it most - the customer-facing staff.

After a rigorous analysis of competitor intelligence offerings from over a dozen providers, Vodafone UK selected Cinergy's Accelerated Intelligence™. The service delivers same-day market tracking and analysis of key competitor information from other mobile operators, major retailers and mobile virtual network operators.

#### The Challenge

With thousands of tariff, handset and offer combinations available in the market, keeping contact centre advisors up to date can seem an impossible task. Vodafone UK recognized this challenge and identified that it required a competitor intelligence tool that would help it to retain existing contract customers, notably at time of contract renewal, and attract more new customers.

The company had initially considered developing its own solution, but had soon found that this would have been excessively costly - both in financial terms and in the amount of resource required - and identified that this was not its core area of expertise.

Vodafone UK also found that there was a dearth of competitor data that was comprehensive and accurate enough for advisors to rely on during high-pressure customer negotiations. The company therefore sought a partner which understood the specific challenges of the mobile telecoms market and which could apply that expertise to the data it delivered.

#### Business Objectives

Vodafone UK's brief was that it wanted to understand its competitive landscape more clearly, to enable it to respond swiftly and effectively to customer requests and to ensure that it had a clear picture of how its offers stacked up against the competition. Specifically, the company wanted this information to be available not just to the management and marketing functions, but directly to advisors in its contact centres who deal with customers day-to-day.

The company also wanted a system that would not have major implications for its IT platforms and which could be integrated into the existing desktops used by contact centre advisors, complete with Vodafone corporate branding.

Finally, Vodafone UK needed an expert in the field that could provide end-to-end support from designing the service, through to delivery, advisor training and rollout across the organization.

#### The Solution: Cinergy AI

Cinergy had already developed its Accelerated Intelligence (AI) competitor intelligence platform for the mobile telecoms market at the time that Vodafone issued its RFP in 2005. By designing an appropriate interface and tailoring specific service modules to meet Vodafone's needs, Cinergy was able to meet the criteria detailed in the RFP and to deliver a fully-working system in a very short timeframe.

After a successful trial, the service was rolled out to the majority of Vodafone's contact centre community around the UK during 2006.



**Key features of Vodafone UK's implementation of Cinergy's AI include:**

- Comprehensive tariff and promotion monitoring
- Handset / device tracking with up to date pricing from all major competitors
- On-demand, side-by-side comparisons of different deals, tariffs and handset options
- Expert analysis and scripted points that enable Vodafone sales advisors to demonstrate 'why we're better'
- Fully branded interface to match Vodafone UK's Intranet
- Reliable, accurate data analyzed by teams with mobile telecoms knowledge
- A hosted, secure platform

**Delivering Accelerated Intelligence**

Vodafone and Cinergy worked closely together to ensure that Accelerated Intelligence would deliver optimum benefits in terms of improved customer retention and sales. This partnership approach has enabled Vodafone to achieve a swift return on its investment. The company has found that its levels of churn have decreased as more sales advisors become familiar with the system and are able to integrate the Cinergy AI functionality and information into their acquisition and retention processes.

Cinergy supported Vodafone in the development and delivery of induction training on Accelerated Intelligence™ for all contact centre advisors with access to the system. Now that the system is in use, short refresher sessions delivered in the weekly advisor meetings ensure that all advisors are kept up to date as new features are introduced.

Since Cinergy AI was launched in 2006, Cinergy has worked with Vodafone to implement two major upgrades to the system, as well as providing regular enhancements to the interfaces, functionality and database content based on feedback from the advisors who use Cinergy AI every day.

**The Results**

As John Coulstock, a senior manager at Vodafone, explains, "We launched Accelerated Intelligence in Q3 2006 and it is currently in use by a large number of our contact centre advisors. Since we've started using the system, it has contributed to a fall in our churn rates quarter by quarter, ensuring we remain highly competitive in the UK market. We've found that the more our agents use the system, the more sales they are able to close. The Cinergy AI™ application has become an integral part of our customer retention and sales strategy." Vodafone has now renewed its contract with Cinergy for an extended term.

Cinergy's AI service has delivered a range of benefits to Vodafone including:

- A contribution to a reduction in contract churn since its launch in Q3 2006
- Improvement in the rate of saves in consumer and enterprise customer bases
- Reduction in call handling time
- Increased ability to set deals in a market context leading to better acquisition performance
- Improvements in operational efficiency by eliminating onerous, manual data collection
- Improved reporting, trend prediction, forecasting and analysis
- Clear understanding of competitor offerings to improve key pricing messages in advertising, dealer negotiations and channel marketing

Cinergy's Accelerated Intelligence™ has contributed to a 18.6% reduction in churn since its launch in Q3 2006. As Brian Boroff, MD of Cinergy concluded, "This has been an excellent implementation for Cinergy, and Vodafone's innovation and dedication to the project has enabled it to achieve very good results from the Cinergy AI™ system."

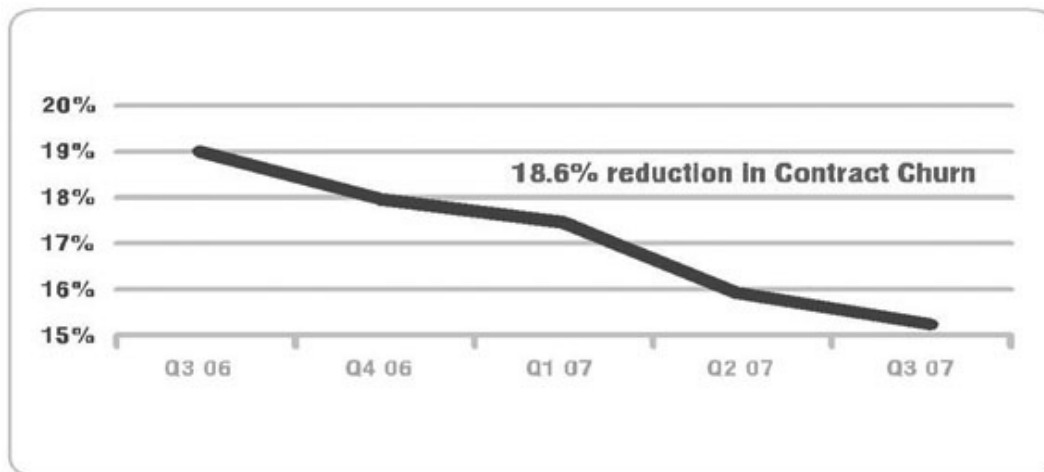

Vodafone UK Contract Churn within One Year of Cinergy AI Rollout

Source: Vodafone KPIs, December 2007

### **About Accelerated Intelligence**

Cinergy's Accelerated Intelligence (AI) puts competitive information into the hands of customer-facing teams, enabling them to counter competitive offers and achieve higher retention and sales performance. The service enables service providers to significantly improve the number of sales they close in a single call, helping to drive down the cost of customer acquisition and retention as well as improving revenues.

Accelerated Intelligence is proven in the UK mobile telecom space having worked with four of the UK's main network operators, delivering an average incremental customer save rate of 1.59% and reduction in call handling time of 22 seconds.

Cinergy International was set up in 2003 to deliver customer acquisition and retention solutions to providers of mobile and fixed telecom, broadband and digital television services.

### **About Vodafone UK**

Vodafone UK has 18.4 million customers and is part of the world's largest mobile community offering a wide range of voice and data communications.

The company is committed to providing mobile solutions that allow both consumer and business customers to make the most of now.

Vodafone customers can now use Internet on your Mobile to view and navigate web pages and their favourite sites such as YouTube, eBay and the BBC.

In addition, Vodafone connects customers across the globe with roaming agreements worldwide. It provides 3G roaming in 29 countries and offers great roaming value with Vodafone Passport.

### **1.8.4 Customer Satisfaction Index (CSI)**

Customer satisfaction scores and customer satisfaction indices are an attempt to measure how satisfied customers are with the performance of the company. The assumption being that the more satisfied a customer is the more likely those are to stay as a customer.

Customer satisfaction has been defined in literature as "the state of mind that customers have about a company when their expectations have been met or exceeded over the lifetime of the product or service". Customer satisfaction leads to customer retention, customer loyalty and product repurchase. Thus its measurement is an important and integral part of an effective Customer Relationship

Management (CRM). Broadly speaking, satisfaction measures involve three psychological elements for evaluation of the product or service experience: (i) cognitive, which depends on the actual use of the product or service by the customer, (ii) affective, which depends on the customer's attitude towards the product or service or the company and (iii) behavioral, which depends on the customer's view regarding another product or service from the same company.

An important implication of the above definition for customer satisfaction is that it is subjective. Due to its non-quantifiability, most companies resort to a survey/questionnaire based assessment for the measurement of their products' perceived satisfaction. In this regard, years of research on customer behaviour has led to specification of ten domains of satisfaction, ranging from quality, efficiency, etc. to commitment to the customer and product innovation. Surveys are designed to touch these domains. What actually to ask in the survey depends on the kind of product or service provided, the kinds of customers served, number of customers served, the longevity and frequency of customer/supplier interactions, and what is to be done with the results. The very nature of such surveys requires the customer to evaluate each statement on a psychometric scale (or a rating scale). Likert scales, semantic differential scales, smiling faces scales and percentage measures are popular in that order. A typical five-level Likert item consists of a statement and asks the surveyee to choose among (a) Strongly disagree, (b) Disagree, (c) Neutral, (d) Agree, and (e) Strongly agree. Several studies exist which show the merit and demerits of different rating scales and how they should be interpreted.

Different organizations use different approaches to measure customer satisfaction but they all tend to fall into two main approaches:

### **Who is the Customer**

The rapidly changing customer:

The expectations and behavior of today's customer is much different than 20 years ago.

- Increasingly time poor
- More savvy
- More demanding

### **Why is Customer Satisfaction important**

Superior customer satisfaction affects bottom line:

- Increased customer loyalty
- Greater pricing leverage
- Increased sales
- Increased usage
- Competitive advantage
- Superior operating results
- Increased financial performance
- Increased market share

### **Customer Satisfaction Index**

A customer satisfaction index combines the customer survey scores from different business attributes to create a single customer satisfaction index that indicates the overall customer satisfaction.

For example adding the customer survey scores for responsiveness, cleanliness, product quality and price then dividing by four. This gives an index with the same range as each of the attribute scores.



The main issue with this approach is determining how important each attribute is in driving customer satisfaction. For example, in reality, your customer satisfaction may be 60% based on price and 10% on each of the other attributes. If that is the case the index created above would give an inaccurate result.

The Customer Satisfaction Index is a fast and effective survey solution that can help you understand and act on customer feedback. Your expertise and commitment to providing high levels of customer service can help ensure ongoing business success for you and your customers.

Understanding what drives customer satisfaction and loyalty is crucial to your organization's continued success. Customer insight can help you retain and deepen your relationships with your customers. It can also help you drive profitability through reduced sales costs and recurring revenue.

Use the Customer Satisfaction Index to:

- Identify areas of strength that could lead to opportunities to improve your business.
- Measure your performance against other partners.
- Maximize the value of the time your organization spends on customer insight and minimize administrative costs.
- Maintain the privacy of customer contact information.

### Customer Satisfaction Score

The other approach is to use a single question in the survey to rate customer satisfaction. There has been lots of research over the year to determine which the best question to ask is.

This does not suffer from the issue above and attempts to directly measure a customer's satisfaction.

The following two questions have become quite popular as customer satisfaction score questions:

- Please think about all of your experiences with Company X. Please rate your overall satisfaction in your dealings with them, where 10 is very satisfied and 1 is very dissatisfied?
- How likely is it that you would recommend Company X to a friend or colleague, where 10 is very likely and 1 is very unlikely?

The customer satisfaction index analysis combines question weights with the value of each response to produce a single 100-point scale index.

The Satisfaction Index is calculated in a simple manner. It takes in a total of at most 5 questions. As a user you can enter the weight that you want to attach to the specific question. For example, you may choose to have the following questions at an overall level for the customer satisfaction index and the corresponding weights.

### Example :

Particulars	Weight
Satisfaction with product / service	25
Willingness to use in the future	35
Level of differentiation from competitors in the industry	15
Willingness to recommend	15

Based on the customer responses that are received, each response is allotted a value of the rating scale minus one times the question weight. The sum of this for all the question is then scaled to produce a 100-point index. See formula below and an example for one response.

**Customer Satisfaction Index formula**

$$CSI = \frac{100}{m-1} \sum_{i=1}^n \sum_{j=1}^n (X_{ij} - 1) \cdot W_i$$

**Example:**

Particulars	Weight	Response	Weighted Average Response
Satisfaction with product / service	25	7	(7-1).25
Willingness to use in the future	35	5	(5-1).35
Level of differentiation from competitors in the industry	15	1	(1-1).15
Willingness to recommend	15	6	(6-1).15

The overall customer index is then calculated by adding the weighted average responses and then scaling it to 100-point scale. The weights are automatically standardized to add up to 1. See final calculation below:

$$(100/7)((7-1)*.25 + (5-1)*.35 + (1-1)*.15 + (6-1)*.15) = 52.14$$

Customer Satisfaction Index

**Characteristics of Firms with Higher Customer Satisfaction:**

- Customers define quality
- Variety of services
- Customization of services
- Convenience of services
- Timeliness of services
- Continually identify factors that influence satisfaction
- Continually identify expectations and set customer service standards well above these expectations ( to "delight" customers)

**Pampering Customer Loyalty- Insight**

Proctor & Gamble's Pampers product had 13% market share in Hong Kong. They went on a massive campaign to gather the names and addresses of mothers and babies through highly successful cash back sales promotion activities. To get the cash back, mothers had to write in with full name and address details, as well as the babies birth date and sex. Using this information they wrote to the mothers on a quarterly basis, telling them of their babies growth and what to expect at the various stages. They also sent out discount vouchers when it was time to buy the next size up, so that the nappies always performed well.

Within 14 months (the fifth cycle of the ever-growing list of mothers) Pampers had moved to the number one position with 49% market share. Each percentage point was worth US\$1million over the life usage of the product. That's \$29million just by staying in touch with the same base, within 3 months over and over.



## **General Measures in a Customer Satisfaction Survey**

### **Product Use**

- Frequency of product use
- Primary use location
- Primary precipitating events or situations for product use or need
- Usage rates and trends

### **Product Familiarity**

- Degree of actual product use familiarity
- Knowledge (read product information, read product label, etc.)
- Knowledge and Involvement with product and the purchase process
- Awareness of other brands
- Reasons for original product purchase (selection reasons)
- Primary benefits sought from the product

### **Product Evaluation**

- Attribute evaluation matrix: (quality, price, trust, importance, performance, value)
- Perceived benefit associations matrix Importance, performance
- Identification of primary benefits sought Comparison to other brands (better, worse)
- What is the best thing about the brand, what could be done better

### **Message and Package Evaluation**

- Packaging size, design
- Advertising Promise, message fulfillment evaluation

### **Value Analysis**

- Expectation of price
- Expectation of relative price (full price, on sale)
- Current price paid

### **Satisfaction Measurements**

- Overall Satisfaction
- Reasons for Satisfaction Evaluation
- Satisfaction with attributes, features, benefits
- Satisfaction with use
- Expected and Ideal Satisfaction-Performance Measures
- Likelihood of recommending
- Likelihood of repurchasing



# Study Note - 2

## PERFORMANCE EVALUATION



### This Study Note includes

- 2.1 Divisional Profitability
- 2.2 Human Productivity and Performance Analysis
- 2.3 Return on Investment (ROI) and Residual Income (RI)
- 2.4 The Distinction Between Economic and Managerial Performance Evaluation
- 2.5 Economic Value Added (Residual Income)
- 2.6 Transfer Pricing
- 2.7 Interaction of Transfer Pricing and Taxation - Post Evaluation of Strategic Business Arrangements

Performance Evaluation is formal determination of an individual's job-related actions and their outcomes within a particular position or setting. In financial trading, its objective is to assess the extent to which the individual added wealth to the firm and/or its clients, and whether his or her achievement was above or below the market or industry norms also called performance measurement.

When a business owner wants to sell his business to potential buyers, certain steps must be followed to ensure the business is beneficial for the buyer at the present state. The buyer wants to know what the business is worth and what potential it has for the given market before making the large investment. This is where a business performance evaluation enters the picture.

### 2.1 DIVISIONAL PROFITABILITY

Divisional profitability or Divisional income is a measure of divisional performance that is equivalent to corporate net income for evaluating overall company performance. Similar to related-party transactions in the context of financial accounting, the calculation of divisional income must consider transactions that occur between divisions, and between the division and corporate headquarters. One type of intra-company transaction is the transfer of goods between divisions. These transfers, represent revenue to the selling division and a cost of inventory to the buying division. Another type of transaction is the receipt of services from corporate headquarters or from other responsibility centers within the company. Examples of such services are human resources, legal, risk management, and computer support. In many companies, these services are "charged out" to the divisions that utilize them.

Because divisional income fails to account for the size of the division, it is ill-suited for comparing performance across divisions of different sizes. Divisional income is most meaningful as a performance measure when compared to the same division in prior periods, or to budgeted income for the division.

#### 2.1.1 Objective

The objective is to develop performance measurement systems for divisions that are significant investment centers in large organizations. Such systems should: (1) provide information for economic decisions, (2) facilitate the control of division operations, (3) motivate managers to achieve high levels of divisional performance so as to further the objectives of the entire organization, and (4) serve as a basis for evaluating the performance of divisional managers.



### 2.1.2 Divisionalization, the need for performance measurement

Divisionalization is the delegation of decision-making responsibility. All organizations divisionalize to some degree; some do it more than others. Decentralization is a necessary response to the increasing complexity of the environment that organizations face and the increasing size of most organizations. Nowadays it would be impossible for one person to make all the decisions involved in the operation of even a small company, hence senior managers delegate decision-making responsibility to subordinates.

One danger of Divisionalization is that managers may use their decision-making freedom to make decisions that are not in the best interests of the overall company (so called dysfunctional decisions). To redress this problem, senior managers generally introduce systems of performance measurement to ensure - among other things - that decisions made by junior managers are in the best interests of the company as a whole. Example 1 detail different degrees of Divisionalization and typical financial performance measures employed.

#### Example 1

Responsibility structure	Manager's area of responsibility	Typical financial performance measure
Cost centre	Decisions over costs	Standard costing variances
Profit centre	Decisions over costs and revenues	Controllable profit
Investment centre	Decisions over costs, revenues, and assets	Return on investment and residual income

Divisionalisation refers to the delegation of profit-making responsibility.

### 2.1.3 Divisional Performance Measurement

Divisional financial performance measurement should distinguish between the performance of divisional managers and the economic performance of the divisional unit (Dearden, 1987; Drury, 2000, p. 796). To evaluate the economic performance of divisions, corporate management requires a periodic reporting system providing attention-directing information.

Such attention-directing information highlights those divisions that require more detailed studies to examine their economic viability and ways of improving their future performance. If the purpose is to evaluate the performance of divisional managers, only those items that are controllable, or influenced by the divisional manager, should be included in the performance measure.

The need to distinguish between divisional managerial and economic performance leads to three different profit measures – divisional controllable profit, divisional contribution to corporate sustaining costs and profits and divisional net income. Divisional controllable profit is advocated for evaluating divisional managerial performance because it includes only those revenues and expenses that are controllable or influenced by divisional managers. Thus, the impact of items such as foreign exchange rate fluctuations and the allocation of central administrative expenses may be excluded on the grounds that managers cannot influence them. However, such expenses may be relevant for evaluating a division's economic performance.

Those non-controllable expenses that are estimated to be avoidable in the event of divisional divestment are deducted from controllable profit to derive the divisional contribution to corporate sustaining costs. Examples of such expenses include the allocation of those corporate joint resources shared by divisions that fluctuate according to the demand for them. Assuming that cause-and-effect allocations can be established that provide a reasonable approximation of the cost of joint resources consumed by a division, then the allocated cost can provide an approximation of avoidable costs. Thus, the divisional contribution to corporate sustaining costs and profits is appropriate for measuring divisional economic performance since – as its name implies – it aims to provide an approximation of a division's contribution to corporate profits and unallocated corporate sustaining overheads.

Divisional net income is an alternative measure for evaluating divisional economic performance. It includes the allocation of all costs. From a theoretical point of view, this measure is difficult to justify, since it includes arbitrary apportionments of those corporate sustaining costs that are likely to be unavoidable unless there is a dramatic change in the scale and scope of the activities of the whole group. The main justification for using this measure is that corporate management may wish to compare a division's economic performance with that of comparable firms operating in the same industry. The divisional contribution to corporate sustaining costs and profits is likely to be unsuitable for this purpose. This is because divisional profits are likely to be overstated due to the fact that, if they were independent, they would have to incur some of the corporate sustaining costs. The apportioned corporate sustaining costs therefore represent an approximation of the costs that the division would have to incur if it traded as a separate company. Consequently, companies may prefer to use divisional net profit when comparing the performance of a division with similar companies.

To compare the financial performance of different companies or divisions, a profitability measure is required that takes into account the differing levels of investment in assets. Return on investment (ROI) meets this need by acting as a common ratio denominator for comparing the percentage returns on investments of different sizes in dissimilar businesses, such as other divisions within the group and outside competitors. It has become established as the most widely used single summary measure of financial performance. According to Johnson and Kaplan (1987), it was developed by Du Point in the early 1900s and since then it has become widely used by 'outsiders' to evaluate company performance. Its major benefit is that it provides a useful overall approximation of the success of a firm's past investment policy by providing a summary measure of the ex post return on capital invested. A further attraction of ROI is that it is a flexible measure. The numerator and denominator can include all – or just a subset – of the line items that appear on corporate financial statements. It can be adapted to measure managerial performance by expressing controllable profit as a percentage of controllable investment.

It is more appropriate, however, to use ROI for evaluating the economic performance of a division than managerial performance, since controllable profit and assets are not reported in external published financial statements. Therefore, it is impossible to compare divisional controllable profit as a percentage of controllable assets with similar companies outside of the group. For comparing the economic performance of a division, net income is likely to be the preferred profit measure to be used as the numerator to compute ROI, to ensure consistency with the measures that are derived from the financial reports of similar companies outside of the group.

Return on investment (ROI) has a major weakness if used to evaluate divisional managerial performance: the measure may encourage divisional managers to maximize the ratio, which can lead to suboptimal decisions. For example, a manager heading a division that is currently earning a 30 per cent ROI might be reluctant to accept an investment project yielding a 25 per cent return, as this would dilute the division's ROI. However, if the company's (and the division's) cost of capital is 15 per cent, the project is likely to yield a positive net present value and ought to be accepted. Alternatively if the divisional existing ROI was 10 per cent, acceptance of a project expected to yield a return of 13 per cent would increase the existing ROI, even though its return is less than the cost of capital. In order to overcome the problems attributed to the use of ROI, textbooks recommend that residual income should be used to evaluate divisional managerial performance.

Controllable residual income involves deducting from controllable profit a cost of capital charge on the investment controllable by the divisional manager. The main argument for advocating the use of residual income is that it increases the likelihood of divisional managers investing in projects if they have positive net present values (NPV).

#### **Return on Investment:**

**Return on investment (ROI)** is calculated as:

$$\text{Return on investment} = \frac{\text{Divisional Income}}{\text{Divisional Investment}}$$

The same issues arise in determining the numerator in ROI as arise in the previous subsection with respect to deriving divisional income. As regards the denominator, senior management must decide whether and how to allocate shared assets among divisions, such as service departments at the corporate level, or shared manufacturing facilities. Also, management must decide how to value the capital assets that comprise the division's investment. These assets can be valued at their gross book value (the acquisition cost), their net book value (usually the acquisition cost minus depreciation expense), or less often, some other valuation technique such as replacement cost, net realizable value or fair market value. The calculation of the numerator should be consistent with the choice of valuation technique in the denominator. For example, if divisional investment is calculated using gross book value, then divisional income in the numerator should not be reduced by depreciation expense.

One advantage of using gross book value instead of net book value in the ROI calculation is that net book value can discourage divisional managers from replacing old equipment, even if new equipment would be more efficient and would increase the economic profits of the division. This dysfunctional managerial incentive occurs because if the existing equipment is fully depreciated, but is still functional, its replacement can reduce the division's ROI by lowering the numerator (due to increased depreciation expense) and increasing the denominator (because fully depreciated assets have a net book value of zero).

ROI can be broken down into the following two components:

$$\text{ROI} = \frac{\text{Divisional Income}}{\text{Divisional Investment}} = \frac{\text{Divisional Income}}{\text{Divisional Revenue}} \times \frac{\text{Divisional Revenue}}{\text{Divisional Investment}}$$

The first term on the right-hand side is called the **return on sales (ROS)**. It is also called the **operating profit percentage**. This ratio measures the amount of each dollar of revenue that "makes its way" to the bottom line. ROS is often an important measure of the efficiency of the division, and the divisional manager's ability to contain operating expenses.

The second term on the right-hand side is called the **asset turnover ratio** or the **investment turnover ratio**. This ratio measures how effectively management uses the division's assets to generate revenues. Interestingly, this ratio seems to hover around one for many companies in a wide range of industries, particularly in the manufacturing sector of the economy.

Breaking ROI into these two components often provides more useful information than looking at ROI alone, and it is an example of the type of financial ratio analysis that stock analysts conduct in evaluating company-wide performance. In this context, two common specifications for the denominator in the ROI calculation are assets and equity. The resulting ratios are called **return on assets (ROA)** and **return on equity (ROE)**.

At the divisional level, ROI controls for the size of the division, and hence, it is well-suited for comparing divisions of different sizes. On the other hand, similar to the Internal Rate of Return for evaluating capital projects, ROI can discourage managers from making some investments that shareholders would favor. For example, if a divisional manager is evaluated on ROI, and if the division is currently earning an ROI in excess of the company's cost of capital, then the manager would prefer to reject an additional investment opportunity that would earn a return above the cost of capital but below the division's current ROI. The new investment opportunity would lower the division's ROI, which is not in the manager's best interests. However, because the investment opportunity provides a return above the cost of capital, shareholders would favor it.

#### **Residual Income:**

One way in which financial accounting practice fails to follow corporate finance theory is that the cost of debt is treated as an expense in arriving at net income, but the cost of equity is not. Specifically, interest expense appears as a deduction to income on the income statement, but dividends are shown on the statement of changes in shareholders' equity. Hence, net income is affected by the



company's financing strategy as well as by its operating profitability, which can obscure the economic performance of the firm.

A simple solution to this problem is to add back interest expense (net of the tax effect) to net income, to arrive at operating income after taxes. The performance measure called **residual income** makes this adjustment, and then goes one step further, by deducting a charge for capital based on the organization's total asset base:

$$\text{Residual Income} = \text{Operating Income} - (\text{Investment Base} \times \text{Required Rate of Return})$$

The company's cost of capital is often appropriate for the required rate of return.

Residual income is probably the closest proxy that accounting provides for the concept of economic profits; hence, residual income probably comes close to measuring what shareholders really care about (to the extent that shareholders only care about maximizing wealth). Residual income can be calculated both at the corporate level and at the divisional level. Many companies that use residual income at the divisional level do so because management believes that residual income aligns incentives of divisional managers with incentives of senior management and shareholders.

One type of residual income calculation is called Economic Value Added. The calculation of EVA includes a deduction for the cost of capital, and also adjusts accounting income to more accurately reflect the economic effect of transactions and the economic value of assets and liabilities. In general, these adjustments move the income calculation further from the reliability-end of the relevance-versus-reliability continuum, and closer to the relevance-end of that continuum.

### **Limitations of financial performance measures**

Financial performance measures are generally based on short-term measurement periods and this can encourage managers to become short-term oriented. For example, relying on short-term measurement periods may encourage managers to reject positive NPV investments that have an initial adverse impact on the divisional performance measure but have high payoffs in later periods. Financial performance measures are also 'lagging indicators'. They determine the outcomes of management's actions after a period of time. Therefore, it is difficult to establish a relationship between managers' actions and the reported financial results. Financial performance measures are also subject to the limitation that they deal with only the current reporting period, whereas managerial performance measures should focus on future results that can be expected because of present actions. Ideally, divisional performance should be evaluated on the basis of economic income by estimating future cash flows and discounting them to their present value. This calculation could be made for a division at the beginning and the end of a measurement period. The difference between the beginning and end values represents the estimate of economic income. The main problem with using estimates of economic income to evaluate performance is that it lacks precision and objectivity and that the best estimates of future outcomes are likely to be derived from divisional managers.

According to Johnson and Kaplan (1987), companies tend to rely on financial accounting-based information for internal performance measurement. This information may be appropriate for external reporting but it is questionable for internal performance measurement and evaluation. The major problem is that profit measures derived from using GAAP are based on the historical cost concept and thus tend to be poor estimates of economic performance. In particular, using GAAP requires that discretionary expenses are treated as period costs, resulting in managers having to bear the full cost in the period in which they are incurred. A possible reason for the use of GAAP for divisional performance evaluation is to ensure that performance measures are consistent with external financial accounting information that is used by financial markets to evaluate the performance of the company as a whole. This may arise because of the preference of corporate management for divisional managers to focus on the same financial reporting measures.

**Illustration 1**

Division A and B are both considering an outlay on new investment projects.

	<b>Division A</b>	<b>Division B</b>
Investment outlay	₹ 1,00,000	₹ 1,00,000
Net return on the new investment	₹ 16,000	₹ 11,000
Current ROI	18%	11%

The company's cost of capital is 13%. Should the project be accepted or rejected?

**Solution:****(i) Using ROI**

$$\text{ROI on New investment} = \frac{\text{Net Return}}{\text{New investment}}$$

$$\text{Division A} = \frac{₹ 16,000}{₹ 1,00,000} \times 100 = 16\%$$

$$\text{Division B} = \frac{₹ 11,000}{₹ 1,00,000} \times 100 = 11\%$$

Division A should reject the new investment as its ROI is 16% which is less than the current ROI of 18%. Division B can accept the investment as its current ROI of 11% is equal to new ROI on new investments.

**(ii) Using RI**

	<b>Division A</b>	<b>Division B</b>
Investment	<u>₹ 1,00,000</u>	<u>₹ 1,00,000</u>
Net Income on new Investment	16,000	11,000
Less : Imputed Cost of capital 13%	<u>13,000</u>	<u>13,000</u>
Residual Income	<u>3,000</u>	<u>(2,000)</u>

Division A should accept the investment as it will make RI of ₹ 3,000 and Division B should reject it because it will give a loss of ₹ 2,000.

**Illustrations 2**

Snow White Ltd has two departments — Cloth and Readymade Clothes. Ready Made Clothes are made by the Firm itself out of cloth supplied by the Cloth Department at its usual selling price. From the following figures, prepare Departmental Trading and Profit and Loss Accounts for the year ended 31<sup>st</sup> March:

Particulars	Cloth Department	Readymade Clothes
Opening Stock on 1 <sup>st</sup> April	3,00,000	50,000
Purchases	20,00,000	15,000
Sales	22,00,000	4,50,000
Transfer to Readymade Clothes Department	3,00,000	—
Expenses - Manufacturing	—	60,000
Selling	20,000	6,000
Closing Stock on 31 <sup>st</sup> March	2,00,000	60,000

The Stock in the Readymade Clothes Department may be considered as consisting of 75% Cloth and 25% other expenses. The Cloth Department earned Gross Profit at the rate of 15% during the year. General Expenses of the business as a whole came to ₹ 1,10,000.



**Solution:**

**Departmental Trading and Profit and Loss A/c for the year ending 31st March (₹)**

Dr.

Cr.

Particulars	Cloth	RM	Total	Particulars	Cloth	RM	Total
To, Opening stock	3,00,000	50,000	3,50,000	By, Sales	22,00,000	4,50,000	26,50,000
To, Purchases	20,00,000	15,000	20,15,000	By, Transfer to RM	3,00,000		3,00,000
To, Transfer from cloth dept.		3,00,000	3,00,000	By, Closing Stock	2,00,000	60,000	2,60,000
To, Manufacturing Expenses		60,000	60,000				
To, Gross Profit c/d	4,00,000	85,000	4,85,000				
	27,00,000	5,10,000	32,10,000		27,00,000	5,10,000	32,10,000
				By, Gross Profit b/d	4,00,000	85,000	4,85,000
To, Selling Expenses A/c	20,000	6,000	26,000				
To, Profit C/d	3,80,000	79,000	4,59,000				
	4,00,000	85,000	4,85,000		4,00,000	85,000	4,85,000
				By, Profit b/d			4,59,000
To, General Expenses			1,10,000				
To, Stock Reserve [See note below]			1,575				
To, Net Profit			3,47,425				
			<b>4,59,000</b>				<b>4,59,000</b>

**Note 1 :** Stock Reserve to be additionally provided is  $7,200 - 5,625 = ₹ 1,575$ ; calculated as under :

Particulars	On Opening Stock	On Closing Stock
Rate of GP on Sales in Cloth Dept	Given = 15%	$4,00,000 \div 25,00,000 = 16\%$
Element of Cloth Stock in Readymade Clothes	$75\% \text{ of } 50,000 = 37,500$	$75\% \text{ of } 60,000 = 45,000$
Stock Reserve required to be maintained	$37,500 \times 15\% = 5,625$	$45,000 \times 16\% = 7,200$

**Note 2:** In this case, it is possible to ascertain the Reserve already created against Unrealized Profit in the Opening Stock. In the absence of information, the Reserve should be calculated on the difference in the Opening and Closing Stocks i.e. ₹ 10,000 in this question. Since the Closing Stock has increased, the Reserve calculated would be debited to P&L A/c. In case of decrease in Stocks, the Reserve would be credited to P&L A/c.

## 2.2 HUMAN PRODUCTIVITY AND PERFORMANCE ANALYSIS

Human capital is the competencies, knowledge, experience and personal attributes tied to a person and available through their own free will. Human capital attributes include acquired education and experience that can be used to produce goods and services with economic value. Capital spending may also include investment in human capital, such as retraining, higher education, and vocational training as ways to increase the supply of labor, reduce unemployment, and provide a more productive workforce.

The economist Adam Smith recognized individual talent and initiative as an intangible quality of people. He distinguished it from labor, which according to his views, can be coerced and is usually seen as strictly imitative (learned or transmitted, via means such as apprenticeship). Individual capital comprises inalienable or personal traits of people, tied to their person and available only through their own free will, such as skill, creativity, enterprise, courage, capacity for moral example, non-communicable wisdom, invention, empathy, non-transferable personal trust, and leadership. Much of Human Resources is complex, Government regulation, Selection and staffing, Compensation and benefits, Dispute resolution.

But developing a motivated and enthusiastic workforce isn't rocket science. People want to be motivated and productive, if only they're allowed to. Trouble is, all too many organizations erect barriers to motivation and productivity. Most of those barriers stem from violation of one of the following principles:

- Respect their dignity
- Respect their intelligence
- Respect their time
- Respect their money
- Then demand loyalty and performance

Modern growth theory sees human capital as an important growth factor. It is the key input in the research and development sector, which generates the new products, services or ideas that underlie technological progress.

In recent decades the development of larger databases has enabled researchers to look more directly at Productivity. Whether traditional proxies of workers' skills acquired on the job, such as workers' age and job tenure, really affect workers' productivity or merely reflect institutionalized practices in salary scales. The relationship between wage increases and productivity increases varies based on whether the firm or the worker pays the costs of training, which is related to the structure of the labor market.

If the labor market is characterized by imperfect competition, bargaining and rent-sharing may occur. Moreover, apart from their wages, workers may receive some kind of non-financial remuneration, and part of the returns to their human capital may be 'back loaded' towards the end of their careers to ensure their loyalty to the firm.

In the human capital literature, it is broadly recognized that apart from workers' participation in training, workers acquire many work-related skills by means of informal on-the job training or 'experience'. In empirical analyses this informal human resource development is measured by proxies such as a worker's tenure (an indicator of the firm specific skills a worker has acquired on the job) and a worker's age (an indicator of the general skills a worker has acquired on the job). These empirical studies generally show that workers' experience contributes to their productivity, in as far as this is indicated by the wages they earn. One might, however, wonder whether workers' experience really contributes to their productivity. This question was already posed in the early human capital literature (Mincer, 1974). Workers' life-cycle earnings growth might reflect institutional arrangements in salary-scales rather than productivity gains, and need not necessarily reflect the productivity enhancing effects of the various skills workers have (cf. Medoff & Abraham, 1980, 1991; Brown, 1989).

It is important to note that, with respect to the human capital embedded in the workforce of a firm, studies of the effects of human resource development (HRD) on firms' productivity merely focus on participation in training, and do not include aggregate measures of workers' stock of training investments nor the level of the relevant skills of the workers (cf. Lynch, 1998). As the existing human capital literature is not conclusive regarding the effects of HRD on workers' wages and firm productivity, the following alternative hypotheses can be stated:

- Hypothesis 1a: Human Resource Development will have positive effects on both firm productivity and workers' wages.

- Hypothesis 1b: Human Resource Development will have different effects for workers and the firm that employs them.

### 2.2.1 Labour productivity (cost-effectiveness)

The term 'Labour Productivity' is generally defined as "the ratio of physical amount of output achieved in a given period to the corresponding amount of labour expended". It may be true that any business organization all wage payments are directly or indirectly based on the skill and productivity of the workers, therefore labour productivity is considered as the most important factors in productivity computations. There are various types of methods for calculating the labour productivity. Very simple method describe in the above definition. 'Output divided by input' another method the output per man-years or man-hour and the input per man-years or per man-hour.

Profitability is inevitably critical in shareholder-owned firms. However, it can be affected by financial factors not connected to workforce management (such as movements in exchange rates), so it is better to focus on labour productivity as a measure of human resource management in the firm. We use the notion of labour productivity to mean the value of labour outputs in relation to the cost of labour inputs. Several authors have argued that labour productivity ought to be seen as the primary goal of a firm's labour management. It is the touchstone against which every new HR policy ought to be evaluated: will it make labour more productive and will its costs, or the investment it implies, be justified? In other words, is it cost-effective?

The criterion of cost-effectiveness is the obvious one to apply to all proposed HR policies. HR policies, like any investment in the firm, should provide an adequate pay-back. Let's consider, for example, the idea of developing a formal performance appraisal process with written performance criteria and appraisal interviews. Such formal processes are almost immediately discounted in small firms. While they can be helpful, if well designed and relatively objectively implemented, they are usually regarded as too bureaucratic and thus too costly. The potential benefits do not justify the cost. On the other hand, the small firm's managers are likely to use timely, informal feedback on performance. This is certainly cost-effective and it would be foolish not to give direct feedback quickly in cases of poor performance. The objective of cost-effectiveness implies that the test of likely benefits to costs should be applied to every HR policy proposal.

Let's now raise the level of analysis to the system level. In 'macro' or strategic HRM, cost-effectiveness becomes a criterion for the overall system of HRM in the firm. Is the overall *combination* of HR philosophy, processes, policies, programmes and practices creating the human performance desired and is it doing so at reasonable cost (Godard 2001a)? Very expensive, high skill models of labour management, incorporating rigorous selection, high pay, and extensive internal development, are unlikely among small firms in the retail sector, for example. While firms in this sector should try to find ways of making competitive pay offers and of keeping their most effective staff, this does not imply that they should adopt the kind of HR system needed to compete with international consultancy firms or automobile manufacturers. Another example of the principle of cost-effectiveness is given by Godard and Delaney (2000: 488):

**... in a nuclear power plant employing many workers, the costs of poor morale, (labour) turnover, and strikes can be high, so the benefits of HRM innovations will tend to be high. Firm size may also introduce important economies of scale, reducing the costs of HRM innovations per worker. Thus, in this plant, the benefits of new practices can be expected to exceed the costs. In a small, low-technology garment factory employing unskilled labour, the opposite may be true.**

As Godard and Delaney (2000) imply, expensive HR practices are often justified where the production system is capital intensive or where high technology is involved. The actual level of labour cost could be quite low (say, ten per cent or less of total cost) but workers have a major effect on how well the technology is utilised or exploited. It thus pays to remunerate and train them very well, making better use of their skills and ensuring their motivation is kept high. As they find ways of making the equipment meet or even exceed its specifications, the unit cost of labour falls and productivity rises. Thus, in this



kind of context, the firm can easily sustain high wage levels. It is more important *not* to alienate this kind of labour, because of the productivity impacts of disrupted production, than it is to worry about wage levels. As Osterman (1987: 55) explains:

The concept of cost must be broadened to include potential as well as actual costs. Employees can impose costs on the firm through errors of various kinds. For example, a particular kind of capital equipment may be simple to operate and require little skill but yet be very expensive and subject to damage through employee error. Many firms will choose to employ higher-skill labour and create stable employment systems ... because of potential downside costs.

These examples help to illustrate the point that it is wrong to confuse wage levels with unit labour costs or, similarly, to confuse cost minimisation with cost-effectiveness. In certain cases, where markets are very competitive and where technology is limited and the work is labour intensive, wage levels are decisive in the assessment of cost-effectiveness. In these situations, cost-effectiveness does broadly equate with labour cost minimisation because labour cost levels have such a huge impact on the survival of firms. This is why so much basic apparel manufacturer (such as undergarments), footwear manufacturer, and toy manufacturer, has moved to low wage countries. On the other hand, more complex and capital intensive design functions can usually be kept in high wage countries where a small team of well-paid designers uses computer-aided equipment and keeps in close contact with marketing colleagues and with retail buyers external to the firm.

Clearly, then, the problem of securing cost-effective labour, of making labour productive at reasonable cost, invites some careful thinking about likely costs and benefits. There are indeed situations where wage levels are in competition. When this occurs in manufacturing, firms worry about where to site production facilities to take advantage of lower wages. When it occurs in services, firms typically use employment practices that keep their service costs competitive: wages paid are relative to 'the going rate' in the local labour market (but rarely superior to it), the training investment is sufficient to ensure basic quality, and labour turnover levels are often high. Quality may be no better than average but this may be quite acceptable with customers if the price is right. On the other hand, there are situations where wages are not in competition but the interaction between labour and technology needs to be carefully managed to achieve high productivity. Here, high levels of HR investment pay high dividends and help to protect against disruption. Similarly, there are areas in the service sector, such as professional services, which are knowledge-intensive. Here, managers see the value of investing in higher salaries, extensive career development, and time-consuming performance appraisal because these practices foster the kind of expert interactions with customers that make it possible for the firm to secure and retain high value-added business.

The key point is that all firms should make an assessment of what kind of HR practices they need to make their labour cost-effective in the particular context they operate in. The driving question becomes: what HR practices are 'profit-rational' in which contexts? The criterion of cost-effectiveness runs across the management of labour in all business organisations. It does not, however, imply the same 'solutions' across all contexts.

### **2.2.2 Performance appraisal**

Performance appraisal is a systematic way of reviewing and assessing the performance of an employee during a given period of time and planning for his future. It is a powerful tool to calibrate, refine and reward the performance of the employee. It helps to analyze his achievements and evaluate his contribution towards the achievements of the overall organizational goals. According to Flippo, a prominent personality in the field of Human resources, "performance appraisal is the systematic, periodic and an impartial rating of an employee's excellence in the matters pertaining to his present job and his potential for a better job." (Smita A.K., 2011).

By focusing the attention on performance, performance appraisal goes to the heart of personnel management and reflects the management's interest in the progress of the employees. Performance appraisal is a most valuable human resource tool. It is a vital component for the development of company as well as for individual employee.



The system of performance appraisal motivates the sincere employees and in certain cases it punishes the dishonest employees. This is beneficial to employees as well as for the organization. According to many research in this field can be mentioned the role of performance evaluation in improving the productivity of human resources. Human resources productivity increases if there is a fair performance appraisal system implemented in the organization. Performance appraisal plays critical role in organizations ability to achieve its strategic goals. Organization and the HR department has to design and implement Performance appraisal system in an organization. The challenges faced by the present days organization is absolutely depending on the effectiveness of its performance management system which ultimately acts as a catalyst for Employee's effective performance.

The true goal of performance appraisal is employee's development & organizational improvement. Ultimately competitive asset of any organization is its human resources, thus organization should develop employee's productivity. This can be achieved through performance management system which also acts as behavioral change tool and it can also enable performance management system which can improve overall organizations performance.

### 2.2.3 Objectives of Performance Appraisal

The primary purpose of Performance Evaluation is to provide an opportunity for open communication about performance expectations and feedback. Most employees want feedback to understand the expectations of their employer and to improve their own performance for personal satisfaction. They prefer feedback that is timely and given in a manner that is not threatening.

<b>Objectives Of Performance appraisal</b>
➤ To review the performance of the employees over a given period of time.
➤ To judge the gap between the actual and the desired performance.
➤ To help the management in exercising organizational control.
➤ Helps to strengthen the relationship and communication between superior – subordinates and management – employees.
➤ To diagnose the strengths and weaknesses of the individuals so as to identify the training and development needs of the future.
➤ To provide feedback to the employees regarding their past performance.
➤ To provide information to assist in the other personal decisions in the organization.
➤ To provide clarity of the expectations and responsibilities of the functions to be performed by the employees.
➤ To judge the effectiveness of the other human resource functions of the organization such as recruitment, selection, training and development.
➤ To reduce the grievances of the employees.
➤ Facilitating layoff or downsizing decisions
➤ Counseling poor performers
➤ Determining compensation changes
➤ Encouraging coaching and mentoring
➤ Confirming that good hiring decisions are being made
➤ Improving overall organizational performance
➤ Provide an opportunity for the employee and the supervisor to exchange ideas and feelings about job performance

### 2.2.4 Performance appraisal systems: valuable, if astutely managed

The argument here implies that the most important thing a firm can do to improve individual performance is to learn to recruit and retain more effectively. We have stressed the crucial role of thoughtful recruitment strategies and valid selection practices and the complementary role of training and development, especially where significant investment has been made in the staffing process. Improving retention is something we shall explore further below. What about performance planning and appraisal systems? Performance appraisal (PA) systems are formal methods of planning and evaluating employee performance which involve employee interviewing (typically annually). Quite commonly they include some form of employee development planning (although some firms separate these activities).

Clearly, our argument implies that it is wrong to conflate performance appraisal systems with 'performance management'. Individual performance is managed through a variety of techniques - from recruitment to termination (Figure). Current reviews stress that PA systems can play a productive role in this mix of techniques, but only if they are managed astutely (Bradley and Ashkanasy 2001, Latham and Latham 2000, Marshall and Wood 2000). People have long been able to see a valid and important role for formal performance appraisal, particularly in major organisations with large numbers of salaried staff (Huber and Fuller 1998).

Research in Britain shows that PA systems are growing as a key way of managing individual performance, particularly in managerial and professional work (Gallie, White, Cheng and Tomlinson 1998). As noted above, the spread of performances in work with higher levels of discretion is vast and it seems only logical to manage each 'human asset' in an individualised manner. PA systems can form a basis for individual work planning, for discussing 'critical success factors' in the job, and can provide the key (if not the only) input to decisions on merit-based salary increases, training, promotions, and international transfers. It is hard to see how multinational firms, involved in time-consuming expatriate management, can operate without a formal PA system for assessing performance and potential (Dowling, Schuler and Welch 1994).

The problem we must wrestle with is that good intentions in the PA area have often been associated with disappointing outcomes. As well as huge variability in how (or even whether) managers conduct formal interviews, research has long confirmed the existence of 'rater bias', stemming from use of invalid performance criteria and lack of representative data on performance (amongst other things). As a result, some industrial psychologists now routinely distinguish between 'objective' and 'rated' performance in organisations (Hunter et al. 2000). The implication is that good performers are insufficiently recognised. They also tend to be frustrated with senior management because PA systems raise expectations of links to rewards and development which are often not forthcoming. Too many managers see appraisal interviews as a chore to be got out of the way (as another management system with which they are forced to comply). Their staff typically see them as an opportunity to have their good work rewarded and further developed. Staff are often concerned with the links to the other parts of the HR cycle (Figure). Not surprisingly, then, a key-concern in the appraisal literature over many years has been similar to that in the selection field: how to make the whole process more valid or how to improve its 'cognitive properties' (Huber and Fuller 1998).

Cognitive problems must have something to do with the frustration with PA systems and better management training is bound to be part of the answer, provided it actually involves effective practice at better techniques (Latham and Latham 2000). However, in recent years, some key writers in the literature have started to realise that the problem is not simply cognitive. The idea that better training is the answer assumes that managers are not perversely motivated. The work of writers such as Murphy and Cleveland (1991), who point out that managers have goals of their own which may not include giving accurate appraisals and who act in a political context, is attracting greater attention (Huber and Fuller 1998, Latham and Latham 2000). This kind of approach resonates with the work of Kets De Vries and Miller (1984) who discuss a range of dysfunctional managerial behavioural and personality syndromes including 'powerholic' and 'workaholic' problems, and infantile jealousies of more productive people.

Admitting the possibility of motivational and political problems implies that senior managers must improve accountability mechanisms around PA systems - for example, requiring lower-level managers to summarise and justify all proposed evaluations in advance of interviewing any employees (Marshall and Wood 2000). Senior managers can also improve systems by spending time better clarifying their purposes and how key linkages to rewards and development will actually be achieved consistently in practice (Marshall and Wood 2000). All of this is a tall order. It seems, then, that PA systems can be used effectively when they are well-led and well-resourced. In this light, small firms might be well advised to stick with good informal performance management and some 'golden rules' (such as aiming to hire as well as they can and intervening early in any case of poor performance). In large organisations, however, such as large public companies and government ministries, this will not do. The problems of planning work and rewarding performance are simply too great to rely on informal methods.

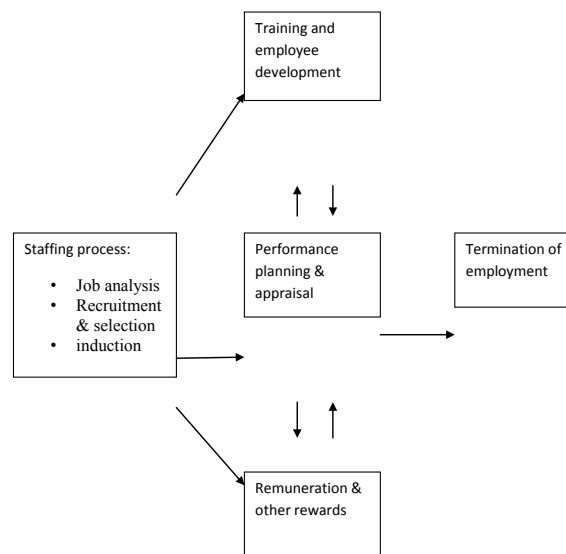

### 2.2.5 The Benefits of Performance Management

Managers are inundated with a high volume of information and required to make multiple decisions daily. It is often difficult to be fair and consistent in decisions when the manager is operating on a reactive rather than proactive basis.

Performance management gives managers a specific set of parameters to make decisions and act in an active rather than passive mode. This allows them to take the initiative by making quick and effective decisions that positively impact their unit's efficiency, profitability and overall performance.

Managers who utilize an effective performance management process and program will find that rather than complicate their lives, their jobs are made much easier. Decision-making is greatly simplified by performance management, as it provides a specific set of established parameters with which to make consistent and focused decisions that move the unit forward to the achievement of its goals. These parameters include:

#### Alignment of Goals and Objectives

The overall purpose of performance management is the alignment of unit/department goals and activities with the overall goals and objectives of the company.

The role of the manager is to ensure that all goals and activities of his or her individual employees directly contribute to the overall success of the unit. In this capacity, the manager establishes the individual goals and targets to assure that the overall objectives are obtained. Once this has been

accomplished, any decisions to be made regarding the performance of individual employees must be made with each of their goals in mind. Managers are able to make decisions to ensure that every action and activity an employee makes advances him or her toward the accomplishment of their unit's goals.

This decision-making parameter prevents individual employees from becoming "loose cannons," ignoring their unit and company goals and performing in a way they view as expedient. It keeps the employees in line and focused. It also allows managers to fairly and consistently manage and evaluate individual performance against overall team goals.

### **Focus on the Target Market**

Most corporate goals and objectives are designed to move a company forward, while maximizing the utilization of human and physical resources to enhance productivity, efficiency and profitability. In this pursuit, companies are increasingly gearing specific products and services to profitable niche markets where they can gain a competitive advantage.

The use of performance management techniques allows managers to redefine or refine the target market so that it is aligned with the objectives established by senior management. As a decision-making parameter, managers can guide and direct employees through plans to better focus their efforts on these intended niche markets.

As markets are increasingly more competitive, rapid changes and shifts in marketing strategies are often required. The use of performance management criteria allows managers to shift their people's focus and ensure all decisions they make are consistent with this impetus.

### **Guidance**

The company's mission statement, goals and objectives provide guidance to the manager and the basis for their performance management program. Additionally, these provide managers with specific parameters with which to guide and direct their own actions and those of their employees, while also giving them the guidance they need when making decisions. There will be times when senior management may need to clarify issues and concerns, but the progression of goals and objectives should flow smoothly from senior management to the individual employee.

### **Benchmarks for Performance**

One of the keystones of performance management is the ability to benchmark the individual work of each employee. These provide managers with the tools to monitor and evaluate performance as well as the basis for any decisions and actions that must be made.

The specific performance of an employee influences all decisions a manager makes concerning that individual. An employee performing at a high level will be given more leeway in the decisions made about him or her since results are being produced. A poorly performing individual will have more stringent decisions made about him or her.

### **Pinpointing Performance Problems**

The use of specific metrics in a performance management program allows managers to make decisions regarding performance breakdowns. Initially, it allows the manager to pinpoint problems and take the proper corrective actions to immediately rectify them before they become a major issue.

### **Providing Focused Feedback**

Performance management allows managers to make decisions and focus their feedback on issues directly related to the achievement of the individual employees goals and objectives. Any other issues distracting the employee that don't contribute to the unit or department's performance can be quickly and effectively handled and eliminated.

### 2.2.6 Performance Appraisal Cycle

In the diagram below we can see that the performance appraisal process is not an annual event it is a never ending process, there is no start and no end ... just an ongoing evolution of performance.

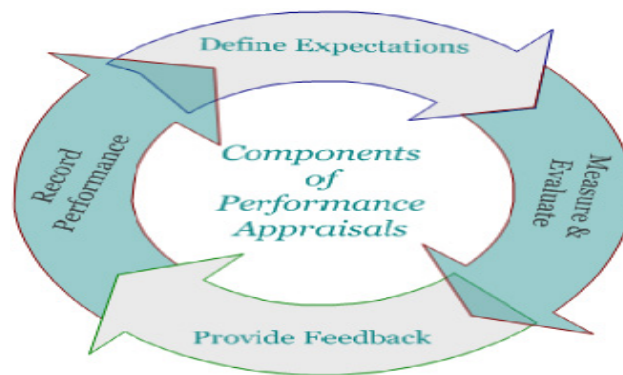

#### Performance Appraisal Methods

It is common to see the two steps "Provide Feedback" and "Record Performance" combined to create a three stage performance appraisal process, as shown below. Now let's start by looking at the definition of a performance appraisal.

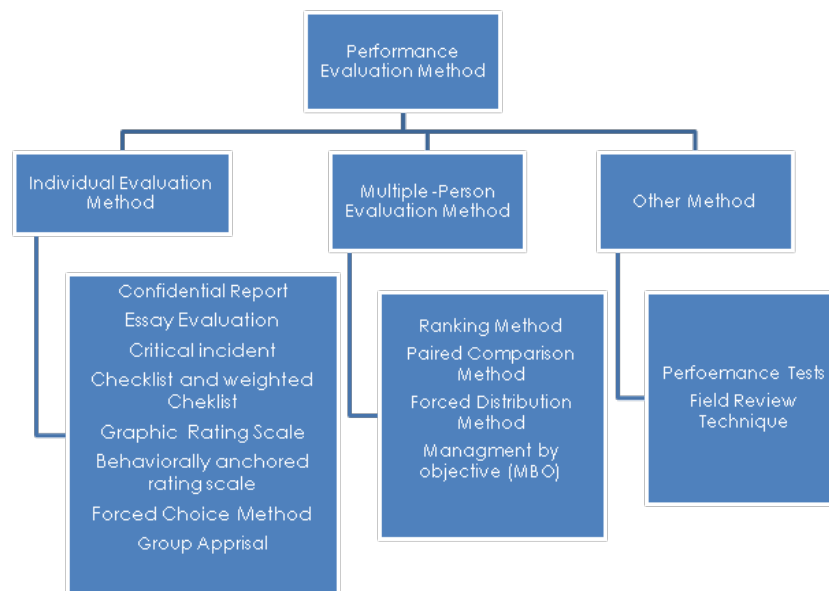

#### (a) Confidential Report:

It is mostly used in government organizations. It is a descriptive report prepared, generally at the end of every year, by the employee's immediate superior. The report highlights the strengths and weaknesses of the subordinate. The report is not data based. The impressions of the superior about the subordinate are merely recorded there. It does not offer any feedback to the appraiser. The appraiser is not very sure about why his ratings have fallen despite his best efforts, why others are

rated high when compared to him, how to rectify his mistakes, if any; on what basis he is going to be evaluated next year, etc. Since the report is generally not made public and hence no feedback is available, the subjective analysis of the superior is likely to be hotly contested. In recent years, due to pressure from courts and trade unions, the details of a negative confidential report are given to the appraiser.

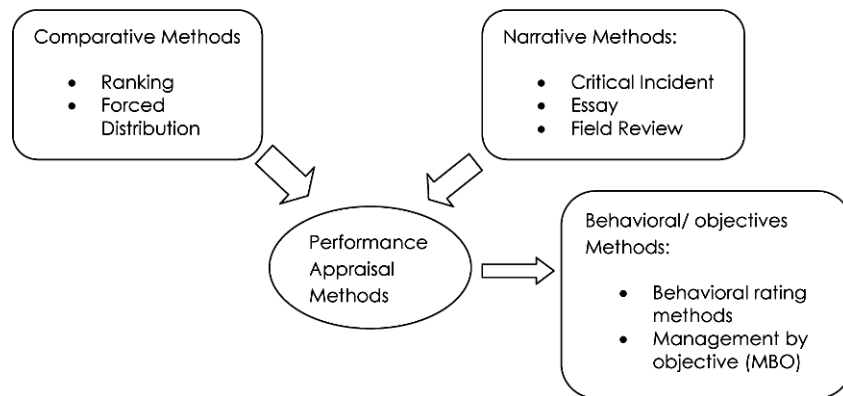

**(b) Essay Evaluation:**

Under this method, the rater is asked to express the strong as well as weak points of the employee's behavior. This technique is normally used with a combination of the graphic rating scale because the rater can elaborately present the scale by substantiating an explanation for his rating. While preparing the essay on the employee, the rater considers the following factors: (i) Job knowledge and potential of the employee; (ii) Employee's understanding of the company's programs, policies, objectives, etc.; (iii) The employee's relations with co-workers and superiors; (iv) The employee's general planning, organizing and controlling ability; (v) The attitudes and perceptions of the employee, in general.

Essay evaluation is a non-quantitative technique. This method is advantageous in at least one sense, i.e., the essay provides a good deal of information about the employee and also reveals more about the evaluator. The essay evaluation method however, suffers from the following limitations:

- It is highly subjective; the supervisor may write a biased essay. The employees who are sycophants will be evaluated more favorably than other employees.
- Some evaluators may be poor in writing essays on employee performance. Others may be superficial in explanation and use flowery language which may not reflect the actual performance of the employee. It is very difficult to find effective writers nowadays.
- The appraiser is required to find time to prepare the essay. A busy appraiser may write the essay hurriedly without properly assessing the actual performance of the worker. On the other hand, some appraiser can take a long time, this becomes uneconomical from the view point of the firm, because the time of the evaluator (supervisor) is costly.

When used in conjunction with other methods, such as the graphic rating scale, the essay method does not require a lengthy statement and can add value to your employee performance evaluations.

**(c) Critical Incident Technique:**

Under this method, the manager prepares lists of statements of very effective and ineffective behavior of an employee. These critical incidents or events represent the outstanding or poor behavior of employees on the job. The manager maintains logs on each employee, whereby he periodically records critical incidents of the workers behavior. At the end of the rating period, these recorded



critical incidents are used in the evaluation of the workers' performance. This method provides an objective basis for conducting a thorough discussion of an employee's performance.

This method avoids recent bias (most recent incidents get too much emphasis). This method suffers however from the following limitations:

- Negative incidents may be more noticeable than positive incidents.
- The supervisors have a tendency to unload a series of complaints about incidents during an annual performance review session.
- It results in very close supervision which may not be liked by the employee.
- The recording of incidents may be a chore for the manager concerned, who may be too busy or forget to do it.

Most frequently, the critical incidents technique of evaluation is applied to evaluate the performance of superiors rather than of peers of subordinates.

#### **(d) Checklists and Weighted Checklists:**

Another simple type of individual evaluation method is the checklist. A checklist represents, in its simplest form, a set of objectives or descriptive statements about the employee and his behavior. If the rater believes strongly that the employee possesses a particular listed trait, he checks the item; otherwise, he leaves the item blank. A more recent variation of the checklist method is the weighted list. Under this, the value of each question may be weighted equally or certain questions may be weighted more heavily than others. The following are some of the sample questions in the checklist.

Is the employee really interested in the task assigned?	Yes/No
Is he respected by his colleagues (co-workers)?	Yes/No
Does he give respect to his superiors?	Yes/No
Does he follow instructions properly?	Yes/No
Does he make mistakes frequently?	Yes/No

A rating score from the checklist helps the manager in evaluation of the performance of the employee. The checklist method has a serious limitation. The rater may be biased in distinguishing the positive and negative questions. He may assign biased weights to the questions. Another limitation could be that this method is expensive and time consuming. Finally, it becomes difficult for the manager to assemble, analyze and weigh a number of statements about the employee's characteristics, contributions and behaviors. In spite of these limitations, the checklist method is most frequently used in the employee's performance evaluation.

#### **(e) Graphic Rating Scale:**

Perhaps the most commonly used method of performance evaluation is the graphic rating scale. Of course, it is also one of the oldest methods of evaluation in use. Under this method, a printed form, is used to evaluate the performance of an employee. A variety of traits may be used in these types of rating devices, the most common being the quantity and quality of work. The rating scales can also be adapted by including traits that the company considers important for effectiveness on the job.

From the graphic rating scales, excerpts can be obtained about the performance standards of employees. For instance, if the employee has serious gaps in technical-professional knowledge (knows only rudimentary phases of job); lacks the knowledge to bring about an increase in productivity; is reluctant to make decisions on his own (on even when he makes decisions they are unreliable and substandard); declines to accept responsibility; fails to plan ahead effectively; wastes and misuses resources; etc., then it can safely be inferred that the standards of the performance of the employee are dismal and disappointing.



The rating scale is the most common method of evaluation of an employee's performance today. One positive point in favor of the rating scale is that it is easy to understand, easy to use and permits a statistical tabulation of scores of employees. When ratings are objective in nature they can be effectively used as evaluators. The graphic rating scale may however suffer from a long standing disadvantage, i.e., it may be arbitrary and the rating may be subjective. Another pitfall is that each characteristic is equally important in evaluation of the employee's performance and so on.

**(f) Behaviorally Anchored Rating Scales:**

Also known as the behavioral expectations scale, this method represents the latest innovation in performance appraisal. It is a combination of the rating scale and critical incident techniques of employee performance evaluation. The critical incidents serve as anchor statements on a scale and the rating form usually contains six to eight specifically defined performance dimensions.

**(g) Forced Choice Method:**

This method was developed to eliminate bias and the preponderance of high ratings that might occur in some organizations. The primary purpose of the forced choice method is to correct the tendency of a rater to give consistently high or low ratings to all the employees. This method makes use of several sets of pair phrases, two of which may be positive and two negative and the rater is asked to indicate which of the four phrases is the most and least descriptive of a particular worker. Actually, the statement items are grounded in such a way that the rater cannot easily judge which statements applies to the most effective employee.

The favorable qualities earn a plus credit and the unfavorable ones earn the reverse. The worker gets over plus when the positive factors override the negative ones or when one of the negative phrases is checked as being insignificantly rated.

The overall objectivity is increased by using this method in evaluation of employee's performance, because the rater does not know how high or low he is evaluating the individual as he has no access to the scoring key. This method, however, has a strong limitation. In the preparation of sets of phrases trained technicians are needed and as such the method becomes very expensive. Further, managers may feel frustrated rating the employees 'in the dark'. Finally, the results of the forced choice method may not be useful for training employees because the rater himself does not know how he is evaluating the worker. In spite of these limitations, the forced choice techniques are quite popular.

**(h) Group Appraisal:**

In this method, an employee is appraised by a group of appraisers. This group consists of the immediate supervisor of the employee, other supervisors who have close contact with the employee's work, manager or head of the department and consultants. The head of the department or manager may be the Chairman of the group and the immediate supervisor may act as the Coordinator for the group activities.

This group uses any one of multiple techniques discussed earlier. The immediate supervisor enlightens other members about the job characteristics, demands, standards or performance, etc. Then the group appraises the performance of the employee, compares the actual performance with standards, finds out the deviations, discusses the reasons therefore, suggests ways for improvement of performance, prepares an action plan, studies the need for change in the job analysis and standards and recommends changes, if necessary. This method eliminates 'personal bias' to a large extent, as performance is evaluated by multiple rates. But it is a very time consuming process.

**(i) Management by Objectives (MBO):**

MBO represents a modern method of evaluating the performance of personnel. MBO is a form of result-oriented appraisal. It is commonly used for supervisors, but may be used for other employees as well. It requires that both the supervisor and the subordinate agree upon specific objectives in



the form of measurable results. The objectives are the standards of performance. MBO is intended to motivate stronger performance on the part of managers and employees. It is assumed that if employees meet their goals, supervisors will meet their goals, and organizations will then meet their goals.

**MBO has the following components:**

- (1) Major objectives to be accomplished within specified dates,
- (2) Action plans and milestones for accomplishing the objectives,
- (3) Periodic meetings with the manager and employee to review progress and make corrections if necessary, and
- (4) An assessment of employee performance at the end of the MBO cycle.

An advantage of MBO is that it is a participative approach in which employees have input in setting their own objectives, as well as being involved in decisions that affect the objectives of the organization. MBO has been criticized as being based on numerical quotas rather than continuous improvement process, and that it focuses on the performance of individuals at the expense of teamwork. It is also very time consuming, requiring a considerable amount of administrative work.

- MBO emphasizes participant set goals that are tangible, verifiable and measurable.
- MBO focuses attention on what must be accomplished (goals) rather than how it is to be accomplished (methods).
- MBO, by concentrating on key result areas translates the abstract philosophy of management into concrete phraseology. The technique can be put to general use (non-specialist technique). Further it is "a dynamic system which seeks to integrate the company's need to clarify and achieve its profit and growth targets with the manager's need to contribute and develop him".

MBO is a systematic and rational technique that allows management to attain maximum results from available resources by focusing on achievable goals. It allows the subordinate plenty of room to make creative decisions on his own.

**(j) Ranking Method:**

This is a relatively easy method of performance evaluation. Under this method, the ranking of an employee in a work group is done against that of another employee. The relative position of each employee is tested in terms of his numerical rank. It may also be done by ranking a person on his job performance against another member of the competitive group. The quintessence of this method is that employees are ranked according to their levels of performance. While using this method, the evaluator is asked to rate employees from highest to lowest on some overall criterion. Though it is relatively easier to rank the best and the worst employees, it is very difficult to rank the average employees. Generally, evaluators pick the top and bottom employees first and then select the next highest and next lowest and move towards the average (middle) employees. The longstanding limitations of this method are:

- The 'whole man' is compared with another 'whole man' in this method. In practice, it is very difficult to compare individuals possessing varied behavioral traits.
- This method speaks only of the position where an employee stands in his group. It does not tell anything about how much better or how much worse an employee is when compared to another employee.
- When a large number of employees are working, ranking of individuals becomes a tosticating issue.
- There is no systematic procedure for ranking individuals in the organization. The ranking system does not eliminate the possibility of snap judgments.

In order to overcome the above limitations a paired comparison technique has been advanced by organizational scholars.

**(k) Paired Comparison Method:**

Ranking becomes more reliable and easier under the paired comparison method. Each worker is compared with all other employees in the group; for every trait the worker is compared with all other employees. For Instance, when there are five employees to be compared, then A's performance is compared with that of B's and decision is arrived at as to whose is the better or worse.

Next, B is also compared with all others. Since A is already compared with B, this time B is to be compared with only C, D and E. By this method when there are five employees, fifteen decisions are made (comparisons). The number of decisions to be made can be determined with the help of the formulae  $n(n-1)/2$ .

For several individual traits, paired comparisons are made, tabulated and then rank is assigned to each worker. Though this method seems to be logical, it is not applicable when a group is large. When the group becomes too large, the number of comparisons to be made may become frighteningly excessive. For instance, when  $n=100$ , comparisons to be made are  $100(100-1)/2 = 4950$ .

**(l) Forced Distribution Method:**

Under this system, the rater is asked to appraise the employee according to a predetermined distribution scale. The rater's bias is sought to be eliminated here because workers are not placed at a higher or lower end of the scale. Normally, the two criteria used here for rating are the job performance and promotability.

Further, a five point performance scale is used without any mention of descriptive statements. Workers are placed between the two extremes of 'good' and 'bad' performances. For instance, the workers of outstanding merit may be placed at the top 10% of the scale. The rest may be placed as – 20% -good, 40% -outstanding, 20% -fair and 10% -fair. To be specific, the forced distribution method assumes that all top grade workers should go to the highest 10% grade; 20% employees should go to the next highest grade and so on. Job performance as the criterion apart, another equally important factor in this method is promotability.

Employees may be classified according to their promotional merits. The scale for this purpose may consist of three points – namely, quite likely promotional material, may/may not be promotional material and quite unlikely promotional material. One strong positive point in favor of the forced distribution method is that by forcing the distribution according to predetermined percentages, the problem of making use of different raters with different scales is avoided. Further, this method is appreciated on the ground that it tends to eliminate rater bias. The limitation of using this method in salary administration however is that it may result in low morale, low productivity and high absenteeism. Employees who feel that they are productive, but find themselves placed in a lower grade (than expected) feel frustrated and exhibit, over a period of time, reluctance to work.

**(m) Field Review Method:**

Where subjective performance measures are used, there is scope for rater's biases influencing the evaluation process. To avoid this, some employees use the field review method. In this method a trained, skilled representative of the HR department goes into the 'field' and assists line supervisors with their ratings of their respective subordinates. The HR specialist requests from the immediate supervisor specific information about the employees performance. Based on this information, the expert prepares a report which is sent to the supervisor for review, changes, approval and discussion with the employee who is being rated. The ratings are done on standardized forms. Since an expert is handling the appraisal process, in consultation with the supervisor, the ratings are more reliable. However, the use of HR experts makes this approach costly and impractical for many organizations.

### **(n) Performance Tests:**

Employee performance testing, including a skills assessment and cognitive abilities test, helps human resource managers evaluate candidates and employees quickly and consistently.

- Reduce the risk of a bad hire.
- Build consistency and efficiency into your employee performance processes.
- Evaluate employee performance.

### **2.2.7 Performance Evaluation Effect on the Productivity of Human Resources**

In a highly competitive era of globalization, human resources have an important role in achieving organizational efficiency and effectiveness by managing the physical, financial and human resources in the most effective and efficient way. To do this, the organizations have developed a variety of complex processes and procedures. Among others, the most important dimensions of managing human resources are the assessment of performance (also known as performance evaluation, performance appraisal, performance management, reviews or ratings) and the implementation of a good salary system. At the same time, employees need feedback about their performance and guidance for their future behavior.

In the human resources management, performance appraisal systems have a vital role. The performance evaluation is an important mechanism for controlling the organization, where employees can view their performance in the immediate past and take concrete actions for improvement. Performance evaluation is affecting the productivity of human resources in different ways. Performance appraisals provide important information for the management of human resources to create fair and correct decisions regarding promotions, transfers, compensation, incentives and training programs and career management. Special companies typically require different performance appraisal system tailored to the needs of the functions and processes.

Although organizational factors contribute to the human resource productivity, probably the most important and influential factor is job performance. Job performance is typically viewed as partially determined by the motivation to work hard and, therefore, increases in motivation should result in greater effort and higher performance (Mitchell, 1982). Furthermore, Mitchell stated that before any motivation system is installed, one must be sure: (a) that there is a good performance appraisal system available, (b) that motivation is important contributor to performance, and (c) that where motivation clearly is not the major contributor to performance, a separate measure of motivation or of behaviors clearly caused by motivation is developed.

Motivation is one of the important factors affecting employee productivity. There are various concepts or theories of motivation that can be used as reference by the managers to learn and understand the various motivations that are owned by their employees within the organization. All considered, that between the motivation and productivity can be said to be a causal relationship, which is one of the impacts on the other side will make an impact on others.

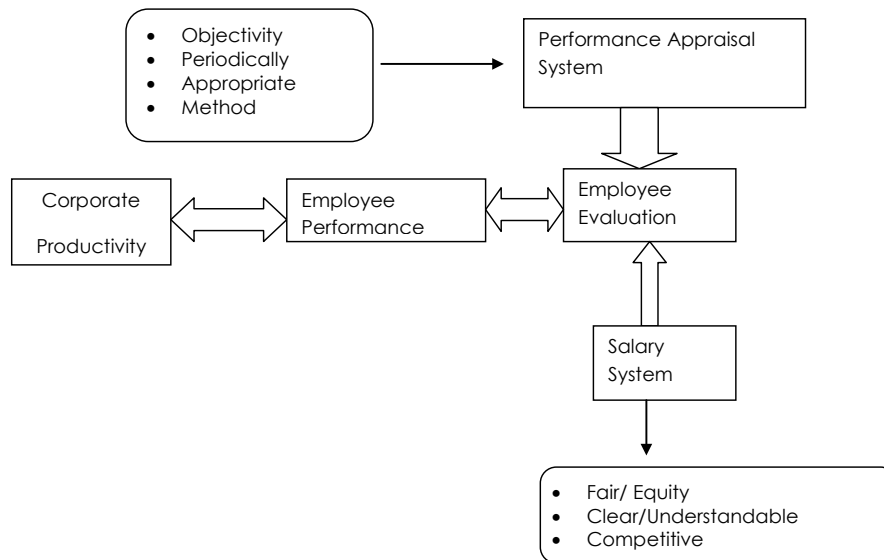

**Fig :** Linkage among Performance Appraisal System and Employee

Performance: Assessment of performance is related to the motivation of employees. Especially the provision of feedback to enable employees to learn how the employee worked; setting specific goals about what employees should do; team-building to enable employees to participate with friends and their managers in solving problems that hinder their productivity, and monetary incentives that reward good performance (Latham *et al.*, 1994).

Work motivation can generate enthusiasm and drive to work. Motivation can come from both internal and external sides. Externally, it can be obtained from the organization. In this regards, managers have duty to create a work environment that conducive to developing motivation. Employees' productivity depends on the amount of time an individual is physically present at a job and also the degree to which he or she is "mentally present" or efficiently functioning while present at a job. Motivation is considered as the main determinant for increased productivity performance.

An employee's productivity depends on employee's motivation to work. In the competitive globalization era, every organization should improve its employees' productivity. It is expected that by the higher productivity competitiveness, the organization will be more profitable and has better performance. It is important to understand how the performance appraisal system will increase employees' productivity. Silber man (2003) noted that "an effective performance management program can increase productivity and morale in your organization and help you retain valued high-performers".

Meanwhile, according to Bruce (2002), the way to increase employees' motivation and productivity is by ensuring everyone to have a common understanding of what high performance is and by ensuring that employees know what is expected from them. Furthermore, she suggested that managers should recognize that they have influence to the employees and should use this influence to convince them that motivation has positive relation with performance.

To improve employees' productivity, the company should implement a good performance appraisal and salary systems to enhance employees' motivation. This is consistent with the goal of formulating the theory that productivity is a function of motivation:  $P = f(M)$ . While according to the expectancy theory, productivity is a multiplication of motivation with the ability:  $P = M \times A$  (Suprihanto, 1986). Productivity represent multiplication function from effort of employees,

supported by high motivation, and ability of human resource through productivity practices which mounting, meaning good performance, will become feedback to continuing organization activity (Klingner *et al.*, 1998). (the follow chart taken from (Cascio, 1992) :

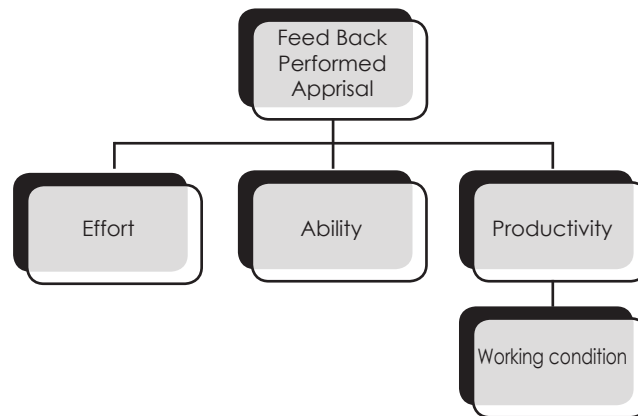

**Fig.:** The relationship between Productivity and Motivation.

### 2.2.8 The canoe race: an example of the stories told about performance management

Once upon a time it was resolved to have a canoe race between a Japanese team and a team representing an NHS Trust. Both teams practised long and hard to reach their peak performance. On the big day they were as ready as they could be. The Japanese won by a mile.

Afterwards the Trust team became very discouraged by the result and morale sagged. Senior management decided that the reason for the crushing defeat had to be found and a working party was set up to investigate the problem and recommend appropriate action.

Their conclusion was that the Japanese team had eight people paddling and one person steering, whereas the Trust team had eight people steering and one person paddling.

Senior management immediately hired a consultancy company to do a study on the team's structure. Millions of pounds and several months later they concluded that 'too many people were steering and not enough paddling'.

To prevent losing to the Japanese next year the team structure was changed to three 'assistant steering managers', three 'steering managers', one 'executive steering manager' and a 'director of steering services'. A performance and appraisal system was set up to give the person paddling the boat more incentive to work harder.

The next year the Japanese won by two miles. The Trust laid off the paddler for poor performance, sold off all the paddles, cancelled all capital investment for new equipment and halted developments of a new canoe. The money saved was used to give higher than average pay awards to senior management.

In case you are inclined to dismiss this story as a piece of unrepresentative mischief-making it is worth noting that in their 1997 survey the IPD reported that a third of respondents believed that performance management was time consuming and bureaucratic and had little or no impact on performance (Donkin, 1997). Such stories illustrate people's tendency, to resist the control that endeavours such as performance management seek to impose on them. The stories, anecdotes and myths in which people tell of their experiences of performance management, as designers, managers or subjects of such schemes, are as much part of the corpus of performance management as the contents of textbooks, organisational policies and procedures.

### 2.2.9 Integration of Individual Productivity into Organizational Productivity

Although there has been considerable research on productivity at the individual, group, and organizational levels, we know little about how changes in productivity at one level affect changes in productivity at another level.

Research opportunities for examining the linkages between individual and organizational productivity are relatively unlimited, given the paucity of studies in this area. We recommend examining the different types of linkages to discover whether increases in individual productivity inhibit or facilitate increases in organizational productivity.

#### Research needs include the following:

- Studying productivity linkages within jobs. Jobs are bundles of linked activities. Most interventions to improve productivity focus on specific sets of activities. There is some evidence that increasing the productivity of certain sets of activities within a job can reduce the productivity of other job activities. For example, Kraut et al. (1989) examined the impact of a new computerized information system on the productivity of customer service representatives. They learned that productivity increased for routine tasks, but dropped for non routine tasks. So the net increase in productivity of that job may be close to zero. Similarly, increases in productivity in certain job activities can simply create additional slack, which does not enhance productivity for the total job or for the organization. Furthermore, some job activities are central to core production activities, while others (e.g., recordkeeping) are more peripheral. Improving productivity in peripheral activities is less likely to affect organizational productivity. We do not understand the linkages between different activities within a job. When will productivity changes in certain activities stimulate positive changes in other activities? When will the opposite occur? We also do not understand when slack will be generated, when slack can have a positive effect on productivity, and when slack will mitigate any greater effects of productivity, given increases in certain job activities.
- Studying productivity linkages between jobs or units. Jobs in organizations are interdependent in varying degrees. Most research has focused on increasing productivity in individual jobs, but not on the consequences of this productivity for jobs horizontally or vertically linked to them. There is some evidence that productivity increases in a particular job may (1) reduce productivity in other jobs, (2) simply create slack that does not lead to productivity in other jobs, or (3) encounter constraints in interdependent jobs that prevent the productivity increases from having an impact on any other part of the organization. The situation is analogous to what occurs among activities within a job. Thus, increases in productivity in one job may decrease productivity in other jobs, leading to a net productivity gain of zero. The basic research question is, how do changes in one job positively or negatively affect other linked jobs? There is a need for a well-developed theory or research paradigm to help us predict when increases in productivity in one job would enhance the productivity in a horizontally, or vertically, linked job.
- Studying linkages and organizational type. Organizations differ in the interdependence and complexity of their linkages. Some organizations, for example, have pooled interdependence: different departments are fairly independent, but the products of all these departments need to be pooled together to achieve an organizational product. A department store is an example of pooled interdependence. Some organizations have other forms of interdependence: an assembly line is a form of serial interdependence; a hospital might illustrate reciprocal interdependence. Even organizations with the same type of interdependence may vary in complexity or simply in the number of different linkages. Linkages between individual, department, and organizational productivity in pooled interdependence differ from the linkages in serial or reciprocal interdependence. For example, because department store units are relatively independent, increasing productivity in one unit should contribute fairly directly to increases in organizational productivity. In contrast, the effect of productivity increases in any unit of an assembly line depends, to a large extent, on what happens in the other interdependent units and, hence, will condition the impact of that unit on organizational productivity (see National Research Council, 1994). We need to understand

how the mechanisms that translate changes in individual-level productivity to organizational-level productivity differ by organizational type. These comparative organizational analyses should provide new ideas about and new insights into the relationship between individual and organizational changes in productivity. Although we have defined organizational type in terms of the form of interdependence, other measures such as size may be relevant.

It is concluded by research that effective performance management system is a key tool of communication & motivation within the organization. There should be the strong support from management for carrying out fair and transparent performance appraisal system. The frame work for Performance Appraisal System has its core elements as improving individual performance in accordance with organizations performance keeping in mind employee's personnel goal. As employees are valuable assets for every organization–by taking an overview on Performance Appraisal System and its profitability to corporate in certain cases the employees may be motivated and on other hand employees are demotivated. But the end result is that unless and until we all are not working as a team organization cannot achieve its productivity, quality and profitability. So the Performance Appraisal System should be taken in a positive way. Organizational capabilities will be built by identifying Key result areas of every individual. The best performer gives the quality work, where effective performance appraisal has a positive effect on HR performance & productivity.

## 2.3 RETURN ON INVESTMENT (ROI) AND RESIDUAL INCOME (RI)

### 2.3.1 Return on investment (ROI)

**Definition:** Return on investment is income from operations or some other measure of return divided by: (1) total operating assets, (2) total operating assets less current liabilities, or (3) net operating assets.

$$\text{Return on Investment (Total Assets)} = \frac{\text{Return}}{\text{Sales}} \times \frac{\text{Sales}}{\text{Total Assets}}$$

$$\text{ROI} = \frac{\text{EBIT}}{\text{Capital employed}} \times 100$$

#### Strengths:

- The amount of return (earnings) is related to the investment base required to generate that return. Thus, the emphasis is on the rational allocation of scarce capital resources.
- ROA normalizes the size effect since it is a ratio. Thus, we can compare entities of different sizes.
- As a percentage-return measure, ROA is comparable to cost-of-capital and market rate of return measures.
- Changes in ROA will lead to changes in EPS. Thus, achieving ROA objectives consistent with a firm's cost of capital will lead to the achievement of desirable levels of total earnings, EPS and corporate ROA.

#### Weaknesses:

- There is no incentive for a division to expand to the point where the marginal return on investment equals the cost of capital.
- ROA can be improved by selling low-return but acceptable projects.
- As an accounting measure, ROA has all of the defects of such measures.

#### The reasons for use of ROI as a measure of performance are:

- Provides incentive to unit managers to balance profit and investments.



- Guides corporate management in making more capital available to units in the organization that are the most effective.
- Provides corporate management a base for measuring relative profitability of different units irrespective of size.

**Note:**

ROI may be used as a measure of performance but it is not advisable to use it as a measure of decision-making on investment.

Sometimes using ROI as a measure may tend to limit growth. Suppose the corporate directors require a 15% ROI for the group, whilst an investment centre or strategic business unit (SBU) currently earns an 18% return. In this case, the SBU management are unlikely to undertake investment which will reduce their ROI to, say 14.5%. But the directors with a view to the corporate goal might prefer a return of 14.5% for the SBU rather than the existing size and ROI of 18%.

The manager of an SBU will care more for short-term profit than for profit in the future. He may neglect R&D and other aspects like staff development and advertising in order to show more cash flow and profit through his accounts and thereby raise his ROI, as his object is to get a promotion to the Board of Directors. He cares little for the long term growth of the company.

Goods and services should normally be transferred between SBUs at fair price but if for taxation or other purposes the price fixed is low, the SBU transferring the goods or services may find the price de-motivating.

### 2.3.2 Residual Income (RI)

**Definition:** Residual income is net operating income or net after-tax earnings plus interest (net of the tax effect) less the desired rate of return on investment multiplied by the amount of investment.

**Strengths:**

The amount of return (earnings) is related to both the investment base required to generate that return and the required rate of return on investment (cost of capital). Thus, the emphasis is on the rational allocation of scarce capital resources.

Residual income focuses on the magnitude of income earned in excess of the cost of capital. Some writers believe managers are primarily interested in magnitudes, not rates of return.

RI is more consistent with the net present value method of selecting capital investments, the preferred method in theory and practice.

RI converts the interest computation to a periodic flow measure which quickly translates into its effect on residual income. Thus, it is easy to translate a change in the cost of capital into its effect on residual income, a flow measure.

The method by which RI is calculated lends itself to the use of different required rates of return for activities with different risk levels.

Changes in RI will lead to changes in EPS. Thus, achieving RI objectives will lead to the achievement of desirable levels of total earnings and EPS at the corporate level.

**Weakness:**

As an accounting measure, RI has all of the defects of such measures.

**Formula of Residual Income:**

**Residual Income = Operating Income – (Investment Base × Required Rate of Return)**

**A Residual Income** requires that each division's profit must bear a charge for capital, say 20%. If profit less this capital charge is positive for a SBU, the efficiency of the SBU is accredited: if otherwise, the SBU must battle hard to turn round.



### Example: (Concept of ROI and RI)

Consider a firm that has a cost of capital of 15%. Consider a division that has the opportunity of making an additional investment of ₹ 120 lakhs which will yield an annual return of ₹ 24 lakhs. Assume that the division has at present an investment base of ₹ 240 lakhs on which it earns an annual return of ₹ 60 lakhs.

ROI on the proposed new investment =  $(24/120) \times 100 = 20\%$ . Since this is higher than the cost of capital of 15%, this investment proposal will qualify for top management approval (assuming other aspects of investment has been approved.)

The division may still not want to make this investment.

Consider the position of the division if this investment is made.

Total investment =  $240 + 120 = 360$ . Total annual return =  $60 + 24 = 84$ .

ROI =  $84 / 360 = 23.3\%$ . Thus with the new investment it would appear that the division's performance as adjudged by ROI has declined. (Present ROI =  $60/240 \times 100 = 25\%$ )

Now analyze the same situation on the basis of Residual Income. Current RI =  $60 - (240 \times 0.15) = 24$

RI after the new investment =  $84 - (360 \times 0.15) = 30$

Thus the division's performance would apparently show an improvement on residual income, justifying the new investment.

#### Note:

Whatever appraisal measure be used, a target level of performance must be set. Factors to be considered include: cost of capital, risks, inter-firm comparisons, economic conditions, and so on.

To control all the facets of divisional operations other appraisal measures should be set in such areas as: sales, growth, productivity, labour relations, quality.

### Performance Measurement

Investment centers are almost like profit centers with the added power of decisions on investment in assets for the division.

The performance measure used is the ability of the centre to generate sufficiently high returns on investments.

Relating profits to capital investment is a well known concept. This can be used as a measure of performance of investment centers.

#### Return on Capital Employed (ROCE) is defined as:

A financial ratio that measures a company's profitability and the efficiency with which its capital is employed. Return on Capital Employed (ROCE) is calculated as:

$$\text{ROCE} = \text{Earnings Before Income and Tax (EBIT)} / \text{Capital Employed}$$

"Capital Employed" as shown in the denominator is the sum of shareholders' equity and debt liabilities; it can be simplified as (Total Assets – Current Liabilities). Instead of using capital employed at an arbitrary point in time, analysts and investors often calculate ROCE based on "Average Capital Employed," which takes the average of opening and closing capital employed for the time period.

A higher ROCE indicates more efficient use of capital. ROCE should be higher than the company's capital cost; otherwise it indicates that the company is not employing its capital effectively and is not generating shareholder value.

ROCE is a useful metric for comparing profitability across companies based on the amount of capital they use. Consider two companies, Alpha and Beta, which operate in the same industry sector. Alpha

has EBIT of ₹5 million on sales of ₹100 million in a given year, while Beta has EBIT of ₹7.5 million on sales of ₹100 million in the same year. On the face, it may appear that Beta should be the superior investment, since it has an EBIT margin of 7.5% compared with 5% for Alpha. But before making an investment decision, look at the capital employed by both companies. Let's assume that Alpha has total capital of ₹25 million and Beta has total capital of ₹50 million. In this case, Alpha's ROCE of 20% is superior to Beta's ROCE of 15%, which means that Alpha does a better job of deploying its capital than Beta.

ROCE is especially useful when comparing the performance of companies in capital-intensive sectors such as utilities and telecoms. This is because unlike return on equity (ROE), which only analyzes profitability related to a company's common equity, ROCE considers debt and other liabilities as well. This provides a better indication of financial performance for companies with significant debt.

Adjustments may sometimes be required to get a truer depiction of ROCE. A company may occasionally have an inordinate amount of cash on hand, but since such cash is not actively employed in the business, it may need to be subtracted from the "Capital Employed" figure to get a more accurate measure of ROCE.

For a company, the ROCE trend over the years is also an important indicator of performance. In general, investors tend to favor companies with stable and rising ROCE numbers over companies where ROCE is volatile and bounces around from one year to the next.

### Another measure is that of Residual Income (RI)

**RI = Profit – Capital Charge = Profit – (Investment × capital charge rate)** where capital charge rate is the minimum rate of return that is expected at the organizational level and set by top management. Usually this is taken as the cost of capital of the company as a whole.

### Illustration 3 :

A company earns a profit of ₹3,00,000 p.a. after meeting its interest liability of ₹1,20,000 on 12% Debentures. The tax rate is 50%. The number of equity shares of ₹10 each are 80,000 and retained earnings amount to ₹ 12,00,000. The company proposes to take up an expansion scheme for which a sum of ₹ 4,00,000 is required. It is anticipated that after expansion, the company will be able to achieve the same return on investment as at present. The funds required for an expansion can be raised either through debt at the rate of 12% or by issuing equity shares at par.

Required to compute the ROCE.

### Solution:

<b>(1) Capital Employed before expansion Plan (₹)</b>	
Equity Shares	8,00,000
Debentures (₹ 1,20,000 /12) x 100	10,00,000
Retained Earnings	12,00,000
<b>Total Capital Employed</b>	<b>30,00,000</b>

<b>(2) Earnings before the Payment of Interest and Tax (EBIT) (₹)</b>	
Profit	3,00,000
Interest	1,20,000
<b>EBIT</b>	<b>4,20,000</b>

### (3) Return on Capital Employed (ROCE)

$$\text{ROCE} = \frac{\text{EBIT}}{\text{Capital Employed}} \times 100 = \frac{4,20,000}{30,00,000} \times 100 = 14\%$$



## 2.4 THE DISTINCTION BETWEEN ECONOMIC AND MANAGERIAL PERFORMANCE EVALUATION

In financial trading, its objective is to assess the extent to which the individual added wealth to the firm and/or its clients, and whether his or her achievement was above or below the market or industry norm. This is called performance evaluation or performance measurement.

It can be of three types. These are — (a) Economic Performance Evaluation, (b) Operation Performance Evaluation and (c) Managerial Performance Evaluation.

Managerial performance evaluation is an important problem in management science. In order to evaluate managerial performance fairly, a newly named analytical method is presented here. This method, a two stage relative efficiency model, evaluates managerial performance by eliminating the influence of existing conditions. For example, Empirical results show that managers in firms with relatively superior existing conditions still need to work hard to maintain their competitiveness and achieve better than before performance. On the other hand, managers in those firms with relatively inferior existing conditions can also achieve better than before performance and fair evaluation if they conscientiously make great efforts. The method presented here can avoid penalizing good managers who manage within an unfavorable existing condition as well as avoid rewarding poor managers who manage in a favorable existing condition. In a word, the newly named analytical method is an equitable and objective measuring method for efficiency.

On the hand, Social scientists use a variety of aggregate and disaggregate measures of economic performance to assess how well a society fosters the economic welfare of its citizens. If you wished to compare the performance of the India with another country, such as China, important indicators of success would include: (a) level of economic welfare, (b) economic growth, (c) poverty or inequality, (d) social indicators, such as health, infant mortality, and education, (e) economic and political freedom, (f) freedom from violence.

From point of view of a particular division in an organization, Economic (Activity) Evaluation is concerned with the measurement of the economic productivity of a division relative to both other divisions and other forms of investment. Economic performance evaluation should help managers to make investment-divestment decision.

Managerial evaluation is concerned with the measurement of the performance of individuals as managers of divisions. This score keeping information is of primary interest in the periodic planning and performance review cycle which influences the systems of rewards.

The application of the controllability principle to divisional performance measurement results in the need to distinguish between the economic performance of divisions and the performance of divisional managers. It is advocated that different performance measures should be used to evaluate the economic performance of the divisions and the performance of divisional managers. A separate divisional managerial performance measure applies the controllability principle by excluding those costs that cannot be controlled or influenced by a divisional manager whereas divisional economic measures generally include the allocation of uncontrollable costs based on the principle that, if the divisions were independent companies, they would have to bear such costs.

The limited empirical evidence, however, suggests that the allocation of uncontrollable costs for evaluation of managerial performance is widespread and that the controllability principle often does not appear to be applied in practice. It is apparent that the traditional two-fold classification of costs as being controllable or non-controllable is too simplistic and that the application of the controllability principle lies along a continuum. At one extreme there is no application of the controllability principle with companies holding managers responsible for all uncontrollable factors. At the other extreme there is the full application of the controllability principle where companies tend to hold divisional managers responsible only for controllable factors. In between these extremes managers may be held accountable for some uncontrollable factors and not others.

The choice of appropriate measures of divisional managerial performance has been widely debated in the management accounting literature. One area of debate is the extent to which the controllability

principle should be applied. Should different performance measures be used to evaluate the performance of divisional managers and the economic performance of the divisions or should a single measure be used for both purposes? Another area of debate relates to the choice of appropriate performance measures. The debate was concerned with which traditional financial measures (e.g. net profit before or after taxes, controllable profit, residual income, return on investment) should be used. Over the past decade new measures have emerged such as economic value added and the balanced scorecard.

Non-financial measures have also been given more prominence and the relative emphasis that should be given to financial and non-financial measures, and how they should be integrated, have been subject to debate.

Corporate management requires performance measures to assist in evaluating the economic performance of a division as a whole and its economic viability and future direction. Divisional profit in this case usually, but not always, includes all allocated central costs. In addition, measures are required to evaluate the performance of divisional managers. For evaluating managerial performance conventional wisdom advocates that performance evaluation should be limited to the profit that is controllable or at least influenced by that manager's actions. Examples of costs that would be excluded from controllable profit include foreign exchange rate fluctuations and allocated central administrative expenses.

## 2.5 ECONOMIC VALUE ADDED (RESIDUAL INCOME)

The issue with traditional and accounting measures of the performance of the firm is that they ignore the cost of the resources deployed. They also fail to recognize the value of other assets like intellectual capital that create value for the firm. Although the Market Value Added (MVA) recognizes all such hidden values in the market price of the share, it is also subject to vagaries of the market. In other words, market value includes the value of the intellectual capital but is subject to change as market value changes every moment.

Economic Value Added (EVA), as popularized by Stern Stewart & Co, measures the profit that is earned over and above the cost of capital of the firm. The analysts, firms and investors use it to find the value created by the firm for a given amount of capital employed. Stern Stewart (1991) defined the EVA as the residual income from operating profits after the cost of capital has been earned and can be calculated in the following formula:

$$\text{EVA} = \text{Return on Total Capital Employed} - (\text{Cost of capital} \times \text{Total Capital})$$

In simple words, EVA is net operating profit minus an appropriate charge for the opportunity cost of all capital invested in an enterprise. It is the amount by which earnings exceed or fall short of the required minimum rate of return that shareholder and lenders could get by investing in other securities of comparable risk. The capital charge is the most distinctive and important aspect of EVA.

As against the MVA, which is measured by the market, EVA is an internal measure of performance of the firm. One clear advantage of EVA is its recognition of efficiency of capital along with profits. Conventional measures of performance of firms do not take into account the cost of capital. The EVA compares the profits with cost of capital.

Under conventional financial performance metrics even if some firms are showing profits they may be actually be destroyers of economic value due to lack of efficient utilization of capital. According to Peter F. Drucker, the renowned management thinker, "until a business returns a profit that is greater than its cost of capital, it operates at a loss. Never mind that it pays taxes as if it had a genuine profit. The enterprise still returns less to the economy than it devours in resources. It does not cover its full costs unless the reported profit exceeds the cost of capital. Until then it does not create wealth; it destroys it." EVA corrects this anomaly by factoring in the cost of equity in the cost of financing calculations.

The underlying idea behind EVA is that if managers employ capital they must pay for it, just as if it were a wage. EVA is the measures of wealth that the business creates or destroys. It is the profit the way shareholders define it. If the shareholders expect, say a 16% return on their investment, firm will be said to have created value for them only to the extent that their share of after- tax operating profits exceeds 16% of equity capital. Every thing before that is just building up to the minimum acceptable compensation for investing in a risky enterprise.

The central idea of EVA is to incorporate the cost of capital both of debt and equity. It holds the firm accountable for earnings as well as cost of capital.

EVA, which is a variant of the residual income concept, is not a new discovery. One of the earliest to mention the residual income concept was Alfred Marshall. Alfred Marshall defined economic profit as total net gains less the interest on invested capital at the current rate. Marshall said more than 100 years ago that “When a man is engaged in business, his profits for the year are the excess of his receipts from his business during the year over his outlay for his business. The difference between the value of the stock of plant, material, etc. at the end and at the beginning of the year is taken as part of his receipts or as part of his outlay, according to an increase or decrease of value. What remains of his profits after deducting interest on his capital at the current rate (allowing, where necessary, for insurance) is generally called his earnings of undertaking or management.”

Though the EVA is a variant of the Economic profit concept that was propounded by the economists over a century back, its association with market capitalization is of recent origin. Also the adjustments to the accounting profits to eliminate the potential accounting distortions are unique to EVA.

The two perspectives from which EVA can be defined are as follows:

- (i) Accounting Perspective and
- (ii) Finance Perspective

From Accounting Perspective, EVA is defined as the difference between the firm's Net Operating Profit After Tax (NOPAT) and its weighted- average rupee cost of capital. Since EVA fully accounts for the firm's overall capital costs it differs from traditional metrics of financial performance such as EBIT (Earnings Before Interest and Taxes), EBITDA (EBIT plus depreciation and amortization) and Earnings After Tax (EAT) etc. This analytical difference is important to the firm's owners because the EVA metric is net of both the direct cost of debt capital and the indirect cost of equity capital – as reflected in the shareholders' required return on common stock. From the Accounting Perspective EVA can be mathematically expressed as:

#### **EVA = NOPAT – Capital Cost**

$$= \text{NOPAT} - (\text{WACC} \times \text{Capital Employed})$$

$$= (r \times \text{Capital Employed}) - (c \times \text{capital Employed})$$

Thus,

$$\text{EVA} = (r - c) \times \text{Capital Employed}$$

$$\text{EVA}_t = (r - c) \times \text{Capital Employed}_{(t-1)}$$

Where, WACC = Weighted Average Cost of Capital.

$$= [\text{Cost of Equity} \times \text{Proportion of equity in total capital} + \text{cost of Preference Capital} \times \text{proportion of Preference Capital in total capital} + \text{Cost of debt} \times \text{Proportion of debt in total capital} \times (1 - \text{tax rate})].$$

From Finance Perspective, EVA is expressed in terms of its relationship with MVA. Thus MVA is equal to the present value of the firm's expected future EVAs.

### **MVA = PV of expected future EVA**

For the company management, the EVA framework has important strategic implications. Firms having investment opportunities that are likely to yield a return that exceeds the weighted average cost of capital to be employed in such investments would see a positive momentum in the intrinsic value of their shares due to a positive EVA outlook. In contrast, firms with returns on invested capital that is expected to fall short of the weighted- average cost of capital should evidence share price declines as the adverse EVA outlook lowers the intrinsic value of the firm. Thus, the EVA framework facilitates the company management to take resources allocation decisions that are compatible with the overall objective of shareholders' wealth maximization.

#### **2.5.1 Economic Value Added vs. Market Value Added**

EVA is period-to-period computation, which can be used to monitor the process of value creation and record historically the growth of the enterprise. The MVA can be expressed as the present value of all EVAs. The MVA measures the total performance of the firm in economic terms since its inception. It is cumulative measure while the EVA is a single period measure, usually a year. A firm having a positive EVA is expected to have positive MVA and vice- versa. However, there can be a contradiction in MVA and EVA because the MVA is derived from the share prices, which are forward looking discounting the future potential, while the EVA records performance during a period. We may have negative EVA, yet a positive MVA due to the good potential of the firm.

According to the proponents of EVA other parameters of value like growth, rates of return and dividends do not matter. Growth in EPS will increase MVA only when investments earn more than the cost of capital. Similarly, the rates of return do not matter. What matters is the creation of absolute EVA. Likewise dividend and its growth will be inconsequential as long as the market value falls by the amount of dividend. MVA will be affected only when change in dividend signals some change in fundamental investment policy. The only way for creation of value is undertaking all the projects with positive NPV and rejecting all negative NPV Projects – the standard rule of capital budgeting. Once this is done, growth in both returns and dividend will take care of themselves automatically. This will lead to maximization of both EVA and MVA.

#### **2.5.2 Economic Value Added vs. Traditional Measures of Financial Performance**

Lehn & Makhija, in their study point towards the conceptual superiority of EVA over the traditional measures of financial performance, suggest that EVA is superior to accounting profits as a measure of value creation because it recognizes the cost of capital and hence the riskiness of a firm's operations. In terms of the impact that measures of financial performance have on the stock prices EVA has been found to be most significant. This relationship between EVA and the market value of a company suggested that EVA influences the market value of shares more than other conventional measures of financial performance. This relationship between EVA and MVA has been studied in the recent years in many studies with many methods and with different results.

#### **2.5.3 Computation of EVA**

The computation of EVA is a three- step process.

- (1) Compute the Net Operating Profit After Tax (NOPAT)
- (2) Find out WACC for the firm, and the capital employed and
- (3) Find EVA as below:

$$\text{EVA} = \text{NOPAT} - \text{WACC} \times \text{Capital Employed}$$

Stewart defines NOPAT as the profits derived from the company's operations after taxes but before financing costs and non cash entries, except for depreciation, which is reckoned as "a true economic expense". Stewart's definition of NOPAT incorporates regular non operating income. This is a deviation from the traditional concept of operating profit which restricts the operating profits definition to profits from main operations ignoring other income. But Stewart's definition is more relevant in present day



business. Stewart identified 164 adjustments to be made to the accounting profits as reported in the Profits and Loss Account to eliminate potential distortions in the accounting results based on the Generally Accepted Accounting Principles (GAAP).

Thus the computation of EVA on one hand removes the distortions in profit that are caused due to discretionary accounting treatment of some transactions like R & D expenditure, inventory etc. This is done by making adjustments to the profits to remove such potentials distortions. Such an adjusted profit that is comparable across firms is termed as NOPAT. On the other hand, the EVA model takes cost of total capital employed, including the cost of equity. These two features that are unique to EVA differentiate it from the conventional measures of performance. Besides, they also make EVA a better and more credible measure of firm's financial performance.

#### 2.5.4 No Operating Profit After Tax

In finding **economic profit**, the essential step is to calculate **net operating profit after taxes (NOPAT)**. We get to NOPAT by translating - through a series of adjustments - an accrual-based **income statement** number into a *cash-based* profit number. Although there are three basic steps in the process of finding NOPAT, there is no single correct method for arriving at a final number.

The method an investor uses is a matter of how approximate or precise he or she wants to be. Some critics lament that EVA requires 50-150 adjustments - but many users of EVA agree that most of the answer is found after a dozen or even fewer adjustments. In fact, beyond a handful of adjustments, you are really only fine-tuning the NOPAT number. And, from an investor's standpoint, a multitude of adjustments simply are not necessary. In using economic profit, the investor's priority is consistency and comparability. In other words, calculating EVA with 99.9% precision is less important than ensuring the method of calculation is consistent from year to year and from peer to peer.

#### The Stages of the Process

Getting to NOPAT takes three basic steps:

1. Start with **earnings before interest and taxes (EBIT)**.
2. Make the key adjustments - these come in two flavors:
  - a) Eliminating accounting distortions (convert accrual to cash).
  - b) Reclassifying some expenses as investments (i.e. **capitalizing** them to the **balance sheet**).
3. Subtract cash operating taxes.

#### 1. Start with EBIT (or Something Close to It)

Throughout this point, we build a EVA calculation for the W & D Company (DIS).

#### W & D Company

#### Income statement

2012 Fiscal Year	Millions (₹)
Revenues	30,752
Cost and Expenses	(26,704)
Net Interest Expenses	(617)
Equity in the income of investees	372
Restructuring and impairment charges	(64)
Income before income taxes & minority interests	<b>3,739</b>
Income Tax	(1,179)
Minority Interests	(197)
Net Income	<b>2,363</b>

We will start with the line nearest to EBIT in Order to calculate NOPAT



For better or worse, **GAAP** does not mandate any one particular presentation of the income statement, so we need to pay careful attention to the line items. W & D does not disclose EBIT on the income statement, so the first step in the economic profit calculation requires some work. Instead of reporting EBIT, W & D shows 'income before income taxes & minority interests', which is an *after* (net) interest-expense number.

Therefore, our first important adjustment is to add interest expense back, or to "move it above" the interest expense, so to speak. With this adjustment, our NOPAT number is not reduced by interest paid and is thereby **deleveraged**: we want a number that captures the profits that accrue to all capital holders including lenders.

Before moving on to step 2, we provide in below an illustrated summary of the entire calculation that gets us from the line reporting 'income before income taxes & minority interests' on Disney's income statement to NOPAT. In working through the remainder of the three-step process, we'll break this summary down and examine the underlying calculations.

### Calculating NOPAT

2012 Fiscal Year	Millions (₹)
Earnings before income taxes, minority interests	3,739
<b>Add:</b> Interest Expenses	629
<b>(1) Earnings before Interest &amp; Taxes (EBIT)</b>	4,368
<b>(2) Add:</b> Key Adjustments (See Below)	781
<b>Net Operating Profit (NOP)</b>	5,149
<b>(3) Subtract:</b> Cash Operating taxes (see below)	1,552
<b>Net Operating Profit after Taxes (NOPAT)</b>	<b>3,597</b>

### 2. Key Adjustments: Translate Accrual to Cash, and Capitalize Investments

Adjusting EBIT is two fold and involves (1) converting accrual-based EBIT to a cash-based profit number and (2) capitalizing expenses that ought to be treated as investments. 'To capitalize' is to move an expense to the balance sheet and treat it as a long-term asset instead of a short-term expense - although, here we broaden the term to refer to any adjustment that moves an expense to the balance sheet, becoming either **Debt or Equity**.

Finally, as we move through step 2 of the NOPAT calculation, keep in mind that a capitalizing adjustment changes N OPAT *and* invested capital. The process of capitalizing an expense is a two-way mirror: we must match an income statement adjustment with a balance sheet adjustment.

As you can see from below, our key adjustments (step 2) together culminate into an addition of ₹ 781 million to EBIT, which gives us net operating profit (NOP). From NOP we subtract cash operating taxes (step 3) to achieve NOPAT.

Now, here is the breakdown of the key adjustments (step 2):

#### Key Adjustments

Convert Accrual to Cash	
<b>Add:</b> Increase in the LIFO Reserve	N/A
<b>Add:</b> Increase in allowance for Bad Debt	(21)
<b>Capitalize Debt/ equity Equivalents:</b>	
<b>Add:</b> Implied interest on operating lease	802
<b>Key Adjustments Total</b>	<b>781</b>



The adjustment related to **LIFO** reserve is relevant only to those companies who use LIFO inventory accounting. W & D does not use LIFO, so no adjustment is required here, but it is worth noting the importance of the step for those companies that do use LIFO. If the price of these Companies' inventory is rising, and then **cost of goods sold** (COGS) is pushed up because under LIFO, COGS reflects the cost of the recently purchased, more expensive inventory. Adding the increase in the LIFO reserve (as indicated in above) converts the cost of goods to what it would be under **FIFO** accounting, which is closer to actual cash flows.

The allowance for bad debt is sometimes very revealing. An increase in this account is not a reduction in (loss of) cash; it reflects a decision to acknowledge additional expenses in anticipation of future cash losses (i.e. a portion of receivables that are not collected). Because its increase represents a paper reduction in profits (not an actual reduction in cash), we add it back to get to the cash-based NOPAT.

In W & D case, however, we made a reduction of ₹ 21 million. Why? Because instead of experiencing an increase, the account decreased over the period, and, a decrease in the allowance for bad debts should be subtracted (just as an increase should be added). In lowering this allowance, management is creating a **paper gain**, boosting the calculation of profits! But since this boost is not actual cash, we subtract it ("reverse it out") to get closer to the cash-based number.

The 'implied interest on **operating lease**' is probably the most difficult key adjustment to understand, but if you take the time to grasp the rationale for this adjustment, you'll be well on your way to understanding economic profit. Before studying the adjustment's calculation, we should establish that economic profit translates the operating lease into a **capital lease** - because economically the two leases are similar (even though they are accounted for differently).

A company gets to treat operating leases as expenses, so, unlike the treatment of capital leases, accounting for operating leases places no liability on the balance sheet. But operating leases are a type of **off-balance-sheet financing**, so they need to be put back on the balance sheet. This will treat the operating lease like an asset that is funded with a debt-like obligation. But, as this movement to the balance sheet takes place, NOPAT must be credited for the financing component of the lease expense for the same reason that we added back interest expense to 'income before income taxes & minority interests' in step 1.

There are a few ways to get an estimate for the implied interest on an operating lease. Scientific precision is not necessary (unless perhaps you are dealing with a company with a large portion of assets, such as some retail firms). All companies must disclose their future stream of minimum obligations under operating leases, so this disclosure of future obligations - after the obligations are discounted - serves as an estimate of the **present value** of the obligation. This process is very much like solving the present value of a bond obligation for which we know the cash flows and the interest rate:

### Calculating the Present Value of Operating Lease Obligations Figure

Operating Lease			
Sl.no.	Year	"As Reported" in 10K Footnote (₹)	Present value (₹)
1	2005	5,497	5,149
2	2006	3,213	2,819
3	2007	1,734	1,425
4	2008	1,339	1,031
5	2009	681	491
6	Thereafter	1,408	951
	<b>Total</b>	<b>13,872</b>	<b>11,866</b>

Discount Rate used to PV <sup>(1)</sup>	6.76%
Implied Interest Expenses (₹ 11,866 x 6.76%)	802

(1) Referring to the (nearby) capital lease footnote disclosure, we find that W & D disclosed a total 2004 capital lease payment of ₹40 billion against present value obligations of ₹355 billion . We can divide the ₹40 billion into a ₹24 and ₹16 , respectively of interest and principal reduction. Therefore, an estimate of borrowing expense is about ₹ 24/₹ 355 or 6.76%. i.e. (annual Interest ÷ total debt = discount rate)

In our example above, we used a **discount rate** of 6.76% to convert the reported future obligations into a single present value of ₹11, 866 million. As explained in the footnote above, this illustration of PV uses a precise method - the implied interest rate is borrowed from the company's disclosure of its capital lease obligations, but we could also have plugged in our own reasonable estimate.

### 3. Deduct Cash Operating Taxes

The final step in finding NOPAT is to subtract cash operating taxes (the taxes that a company actually pays with cash) from net operating profits. Truth be told, we could use reported taxes and we would still have a viable economic profit number (although purists would cringe at such a practice). But because in financial reporting, the tax books are separate from the financial statements, the amount that companies pay in taxes may be different than the amount they record as a tax expense. The point in using cash taxes is to capture a true cash return generated from the actual cash investment: what if for some reason our company pays abnormally low taxes in the reported year? Subtracting an estimate of cash operating taxes ensures the NOPAT number isn't "fooled" by reported taxes.

<b>Cash Operating Taxes</b>	
Reported Income Tax Expenses	\$ 1,197
<b>Subtract:</b> Increase in Deferred Tax Liability	238
<b>Add:</b> Tax Subsidy on Deductible Expenses	593
<b>Cash operating taxes</b>	1,552
Deductible Non-operating Expenses:	
Net Interest Expenses	617
Implied interest expenses on operating leases	802
Restructuring and Impairment charges	64
Total Deductible Non-operating Expenses	1,483
Tax Subsidy on Deductible Expenses (40% × ₹ 1,483)	593

In above we show the underlying calculation for the ₹ 1,552 million subtracted in Figure above. First the increase in deferred tax liability is added to the income-tax expense reported on the income statement (the word "expense" connotes "income-statement item"). The difference between the expense and actual taxes paid is slotted into deferred tax liability, as if it were going to be paid in the future. The deferred tax liability therefore increases when companies pay less in cash taxes than they record on their balance sheet. Because the increase is in paper, we subtract it to get closer to actual cash taxes paid.

The addition of the tax subsidy on deductible expenses relates to a principle that should by now be familiar: we want a number that captures tax expenses *before* accounting for obligations to both debt and equity holders. The expenses listed on the income statement that are "above" pretax income (the deductible non-operating expenses) get the benefit of a tax shield: they reduce the reported taxable income and therefore the income-tax expense. These effects are reversed by the addition of the tax subsidy on deductible expenses [total tax-deductible non-operating expenses x tax rate (%)] to the reported income-tax expense.

After we do this, getting our final number, we see that cash operating taxes are higher than reported taxes.



Although this section drills down on the operating lease and cash operating tax calculations, here's a summary of the general calculation of NOPAT that we demonstrate: start with EBIT, make a set of key adjustments to EBIT and then, to get to NOPAT, subtract an estimate of cash operating taxes that would have been paid under NOP.

Keep in mind this is not a comprehensive set of potential adjustments but, *as long as consistency* is maintained when invested capital is calculated, the process shown here is a perfectly reasonable economic profit calculation.

### 2.5.5 Calculating Invested Capital

Calculating invested **capital** is an important step in finding **EVA** because a key idea underlying this metric is charging the company for its use of capital. In order for the company to generate a positive economic profit, it must cover the cost of using the invested capital.

There is more than one way to get to invested capital, but here we use the following three-step method:

1. Get invested **book** capital from the **balance sheet**.
2. Make adjustments that convert **accounting accruals** to cash.
3. Make adjustments that recognize **off-balance-sheet sources** of funds.

#### Step 1 - Pulling Invested Book Capital from the Balance Sheet

Let's start by reviewing the balance sheet. Its basic structure says that **total assets** are equal to the sum of **liabilities**, plus **stockholders' equity**:

<u>Assets</u>		<u>Liabilities</u>
Cash		Short-term debt
Accounts receivable		Customer advances
Inventory		Accounts payable
Other current assets		Accrued liabilities
		Interest payable
		Taxes payable
		Dividends payable
	= Current Assets	= Current Liabilities
Investments		Bonds payable (L.T. Debt)
Goodwill		Common stock
Plant, Property & Equipment		Add'l paid-in capital
Other long-term assets		Retained earnings
	= Long-term Assets	= Stockholders' Equity
<b>Total Assets</b>	=	<b>Total Liabilities &amp; Equity</b>
<b>(i.e., Current Assets</b>		<b>(Current Liabilities +</b>
<b>+ Long-term assets)</b>		<b>Long-Term Debt + Equity)</b>

The first problem with pulling a number directly from the balance sheet is that the balance sheet includes items that are *not* funding sources. And, for purposes of economic profit, we want to include only the company's funds or financing provided by shareholders and lenders. Consider, for instance,

short-term debt, which is a **current liability**. The company borrowed funds, so this does count as a funding source, and as a part of invested capital. But compare this to accounts payable. These are bills or invoices that are owed to the company's suppliers; the suppliers are not really lending funds or investing in the company. As such, accounts payable is not really part of invested capital.

In the chart below, we highlight those accounts on the balance sheet that are part of invested capital. You can think of them as coming from sources that expect a return on this capital:

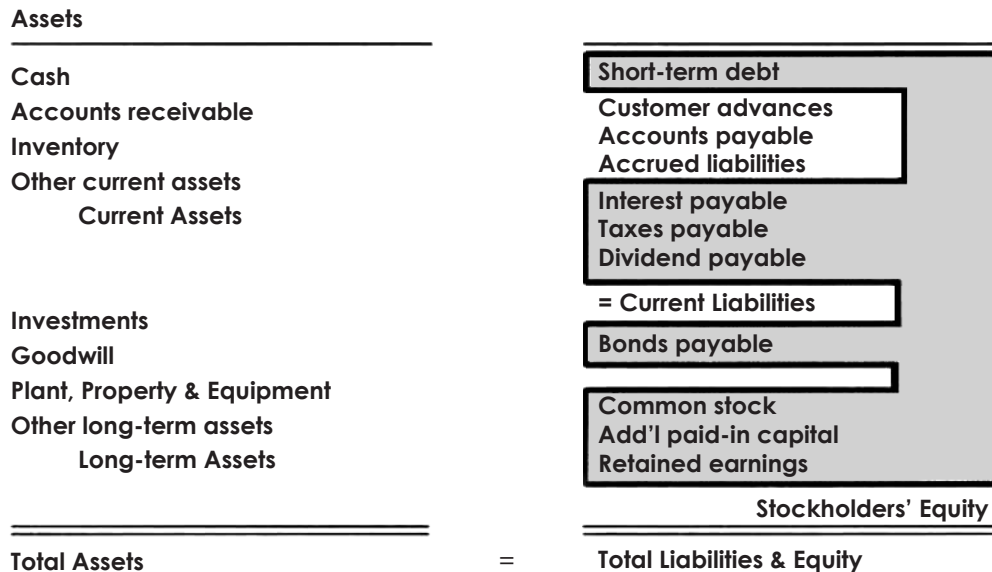

One way to calculate invested capital is to add up the highlighted liabilities on the right-hand side of the balance sheet. However, it turns out in most cases that the items we want to *exclude* from invested capital are typically listed in current liabilities. These items we want to exclude are called **non-interest-bearing current liabilities (NIBCLS)**. So a quicker way to calculate invested capital is to start with the left-hand side (the **assets**) and simply subtract the items on the right that are *not* part of invested capital. In above Figure, they include customer advances, accounts payable and accrued liabilities. Because the left-hand side equals the right-hand side, starting with the left-hand side will get us to the same result as adding up all the highlighted items.

If you look at Figure below, you will see how this equivalency works. We start with total assets on the left-hand side and subtract the NIBCLS. By this process of elimination, we get to invested book capital:

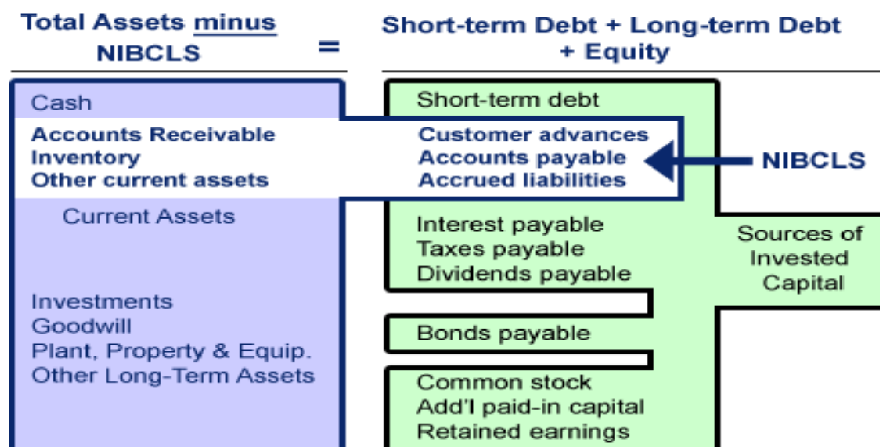

If you are wondering why we don't subtract 'taxes payable', then you are well on your way toward understanding invested capital. You absolutely could exclude taxes payable since the government



doesn't really mean to loan or invest in the company. Actually, including taxes payable is a judgment call. Many analysts let this item remain as a source of invested capital (as we did here) because most companies never pay these deferred taxes. These taxes are perpetually deferred, and for this reason, some call them "quasi equity". If the company were going to pay these taxes, we would exclude taxes payable from invested capital, but since the company - in practice - is going to hold onto the extra cash, we are going to charge them for the use of it.

Now let's perform this calculation on W & D. Below in Figure we show the result of subtracting the non-interest-bearing current liabilities from total assets:

**Name of the Company:** W & D

Balance Sheet as at : 31.03.12

Ref No.	Particulars	Note No.	As at 31.03.12	As at 31.03.11
			(₹)	(₹)
<b>I</b>	<b>EQUITY AND LIABILITIES</b>			
1	<b>Shareholders' fund</b>			
	(a) Share capital		26,081	
	(b) Reserves and surplus		-	
	(c) Money received against share warrants		-	
2	<b>Minority Interest</b>		798	
2	<b>Share application money pending allotment</b>		-	
3	<b>Non-current liabilities</b>			
	(a) Long-term borrowings		9,396	
	(b) Deferred tax liabilities (Net)		2,950	
	(c) Other Long term liabilities		3,619	
	(d) Long-term provisions		-	
4	<b>Current Liabilities</b>			
	(a) Short-term borrowings		4,093	
	(b) Trade payables		5,623	
	(c) Other current liabilities		1,343	
	(d) Short-term provisions		-	
	<b>Total</b>		<b>53,903</b>	
<b>II</b>	<b>ASSETS</b>			
1	<b>Non-current assets</b>			
	(a) Fixed assets			
	(i) Tangible assets			
	(ii) Intangible assets			
	(iii) Capital work-in-progress			
	(iv) Intangible assets under development			
	(b) Non-current investments			
	(c) Deferred tax assets (Net)			
	(d) Long-term loans and advances			
	(e) Other non-current assets			
2	<b>Current assets</b>			
	(a) Current investments			
	(b) Inventories			
	(c) Trade receivables			
	(d) Cash and cash equivalents			

	(e) Short-term loans and advances			
	(f) Other current assets			
	<b>Total</b>			<b>53,903</b>

### 2.5.6 Importance of Consistency between NOPAT and Invested Capital

Notice that, among the liabilities, a **minority interest** account of ₹ 798 million is included in our invested capital number (i.e. we did not exclude it). This minority interest represents partial interests in W & D subsidiaries held by other companies. For example, W & D may own 90% of a subsidiary, while another company owns the other 10%. When the balance sheets are consolidated (or "rolled up"), all of the assets are included in W & D balance sheet, even though 10% of this subsidiary's assets belong to another company. A minority interest account equal to this other company's ownership in the subsidiary is therefore created; this minority interest effectively reduces W & D equity account accordingly.

So why did we include this equity account in invested capital? The reason is the first EVA principle the most important thing is consistency between net operating profit after taxes (NOPAT) and invested capital. The return number (NOPAT) must be consistent with the base number (invested capital). And when we calculated NOPAT, we started with **EBIT**, which is before (or "above") the minority interest deduction on the **income statement** - in other words, our NOPAT number is *not* reduced by the minority interest. So to be consistent, we do not reduce our invested capital by the minority interest.

It would be acceptable, although less common, to subtract minority interest from NOPAT and exclude it also from the invested capital calculation. The important thing to keep in mind is the consistency principle, which can solve many of your dilemmas concerning economic profit adjustments: ask if you included or excluded the account from the NOPAT number and treat the adjustment similarly when working with the balance sheet.

### Steps 2 and 3 - Making the Cash and Balance Sheet Adjustments

Now that we have calculated invested capital, we have only to make the other two types of adjustments: **cash flow** adjustments and off-balance-sheet adjustments. Here again, we are guided by our previous decisions in regard to NOPAT.

#### Key Adjustments

<b>Convert Accrual to Cash:</b>		
<b>Add:</b> Increase in the LIFO Reserve		N/A
<b>Add:</b> Increase in allowance for Bad Debt		(21)
<b>Capitalize Debt/ equity Equivalents:</b>		
<b>Add:</b> Implied interest on operating lease		802
<b>Key Adjustments Total</b>		<b>781</b>

Figure (numbers are in millions)

We are going to match these adjustments on the balance sheet. First, in regard to converting accrual to cash, our goal is simply to adjust the balance sheet to get closer to cash. Second, in performing the important step of **capitalizing** debt/equity equivalents, our goal is to capture investments or debt obligations that - for whatever reason - are not currently on the balance sheet.

W & D has many **operating leases** that are economically equivalent to long-term **capital leases** and therefore represent a debt obligation. In the worksheet below, we perform the cash flow adjustments and off-balance-sheet adjustments:

Sl. no	Particulars	Amount (₹)
1.	Invested Book Capital	46,936
2.	<b>Cash flow adjustments:</b>	
	<b>Add:</b> LIFO Reserve <sup>(1)</sup>	N/A



	<b>Add:</b> Allowance for doubtful accounts (bad debts)	148
<b>3.</b>	<b>Off – Balance sheet adjustments:</b>	
	<b>Add:</b> Present value of operating lease	11,866
	<b>Add:</b> Expenses that were capitalized, like R& D <sup>(2)</sup>	N/A
	<b>Invested Capital</b>	58,950

**Note :**

1. Only applies if company uses LIFO inventory accounting
2. This is an important idea: if the firm expensed R&D, we want to capitalize it as an asset. This simply treats the money spent as if it were spent on a long-term asset like a manufacturing plant.

See how our adjustments to invested capital matched our adjustments to get to NOPAT. In both cases, we adjusted for the allowance for bad debt because it is a paper reserve that does not reflect cash received. In both cases, we treated operating leases like capital leases by adding back the interest component and putting the obligation back onto the balance sheet.

Our worksheet above shows two 'N/As' because, although they do not apply in W & D's case, they are often significant in the EVA calculation. First, if W & D had a **LIFO** reserve, we would add that to the invested capital base. Second, if **research and development** were expensed, we would capitalize it, that is, add it to the balance sheet and thereby treat it as an asset with a long-term payoff.

Invested capital, which we calculated here, reflects an estimate of the total funds held on behalf of shareholders, lenders and any other financing sources. A key idea in economic profit is that, in the calculation, a company is charged "rent" for the use of these funds. Economic profit then represents all profit in excess of this rental charge.

Pulling It All Together - Calculating and Understanding Economic Value Added:

**The Formula**

As a reminder, here is the basic **EVA** calculation:

$$\text{EVA} = \text{NOPAT} - \text{Capital Charge (Invested Capital} \times \text{WACC)}$$

Economic profit is **NOPAT** minus a capital charge, which represents a sort of rental fee charged to the company for its use of capital. In other words, EVA is the profits (or returns) our company must generate in order to satisfy the lenders and shareholders who have "rented" capital to the company. Keep in mind that economic profit is a period metric, like earnings or cash flow.

The only step that we need to perform before the ultimate economic profit calculation is to estimate the capital charge.

**2.5.7 Capital Charge Equals Invested Capital Multiplied by WACC**

We already calculated invested capital, now we need to estimate Disney's weighted average cost of capital (WACC). This is the average return expected by the blended investor base. In order to calculate WACC, we need a cost of debt and a cost of equity.

**Cost of Debt**

We need to make an estimate because the company relies on several different types of debt. We can make this estimate by looking at its long-term debt rating (at the time of the annual report, Disney's Standard and Poor's long-term debt rating was 'BBB+', which is medium grade). Disney's debt rating corresponds to a debt cost of about 5%. (Note that this will be higher than the risk-free rate since it is a corporate bond with credit risk.)

This 5% rate, however, is a pretax cost of debt - companies can deduct interest expense from their tax bill, and reap a true cash benefit. The after-tax cost of debt is therefore lower. To obtain this number



we multiple the pretax cost of debt by the so-called **tax shield** or (1-tax rate). Disney's 2004 effective tax rate is 32%, so the tax shield is 68%, and the after-tax cost of debt equals 5% multiplied by 68%, or 3.4%.

### Cost of Equity

Unlike the cost of debt, which is explicit and can be referenced, the cost of equity is implicit: shareholders expect returns on their investment, but unlike interest rates, these returns are neither uniform nor decided or set.

Because of cost of equity's theoretical basis, there are several methods for calculating it. Here we use the **capital asset pricing model** (CAPM), which is a traditional method but subject to much criticism. In the CAPM, the expected return is a function of one factor only: the presumed risk of the stock as implied by the equity's **beta**. A higher beta implies greater risk which, in turn, increases the expected return - and the expected return is the same as the cost of equity. (Expected return is simply the view from the investor's perspective while cost of capital is the same number from the company's perspective.)

### The CAPM formula says the following: Cost of Equity = Risk-Free Rate + (Beta x Equity Premium)

Let's look briefly at the different elements of the equation. Beta, as a measure of risk, is a measure of the stock's sensitivity to the overall market. A beta of 1.0 implies the stock will track closely with the market. A beta greater than 1.0 implies the stock is more volatile than the market. W & D's beta at the end of the fiscal year was 1.15. This implies slightly more risk than the overall market, on both the upside and downside.

The equity premium is the overall average excess return that investors in the stock market expect above **that of a risk-less investment** like Treasury bonds, which for our calculation is 4%. There is always vigorous debate over what the correct equity premium is (for more on the calculation and debate. We will use an equity premium of 4%, which is middle of the road as some would argue this is too high and some might argue it is too low.

By using the CAPM formula, we add 4.6% (a 4% equity premium x 1.15 beta) to a risk-less rate of 4%. Our estimate for Disney's cost of equity capital therefore equals 8.6%.

The calculations for both Disney's cost of debt and cost of equity are illustrated below in Figure

$$\frac{\text{Pre tax cost of Debt}}{5.00\%} \times \frac{(1 - \text{Tax Rate})}{(1 - 32\%)} = \frac{\text{After Tax Cost of Debt}}{3.4\%}$$

$$\frac{\text{Risk Free Rate}}{4.00\%} \times \frac{(\text{Equity Premium} \times \text{Beta})}{(4.00 \times 1.15)} = \frac{\text{Cost of Debt}}{8.60\%}$$

### 2.5.8 The Weighted Average Cost of Capital

Now we can calculate the WACC. To do this, we simply multiply the cost of debt and equity by their respective proportions of invested capital, and then add the two resulting numbers together.

The proportion of debt and equity depends on the total amount of each, and this information we can find on W & D's balance sheet. If we add up the debt (i.e. long-term debt plus short-term debt plus other liabilities), we get ₹17.11 billion. The market value of the equity (market capitalization) is ₹ 56.962 billion. Debt is therefore 23% of invested capital and equity is 77%. (Note we used the book value of debt - debt from the balance sheet - but we used the market value of equity. Theoretically, we want the market value of both. But it is much easier to get the book value of debt, and it typically tracks very closely to the market value, so we were satisfied to use book value.)

Below, we multiply each type of cost of capital by its respective proportion of total capital. Then we add the two weighted costs together to arrive at WACC.

## The Weighted Average Cost of Capital

Cost		Share Capital		Weighted Cost
3.40%	X	23%	=	0.79%
8.60%	X	77%	=	+6.61%
<b>WACC</b>				<b>7.40%</b>

### 2.5.9 The WACC and Debt-to-Equity Relationship

You may have already noticed that debt is cheaper than equity. There are two reasons for this: first, the pretax cost of debt is lower because it has a prior claim on the company's assets. Second, it enjoys the tax shield (i.e. it is a tax-deductible charge), which is why a balance sheet totally devoid of debt may be suboptimal. Because debt is cheaper, by swapping some equity for debt, a company may be able to reduce its WACC.

So why not swap all equity for debt? Well, that would be too risky; a company must service its debt, and a greater share of debt increases the risk of default and/or bankruptcy. In Figure below, we graph estimates of WACC for Disney at different **debt-to-equity ratios**. At a debt-to-equity ratio of 0.9, the graph plots a minimum value. In theory, this would be Disney's optimal capital structure because it minimizes their cost of capital - after 0.9; higher ratios begin to produce a higher WACC. But, this is merely theoretical and depends on our assumptions.

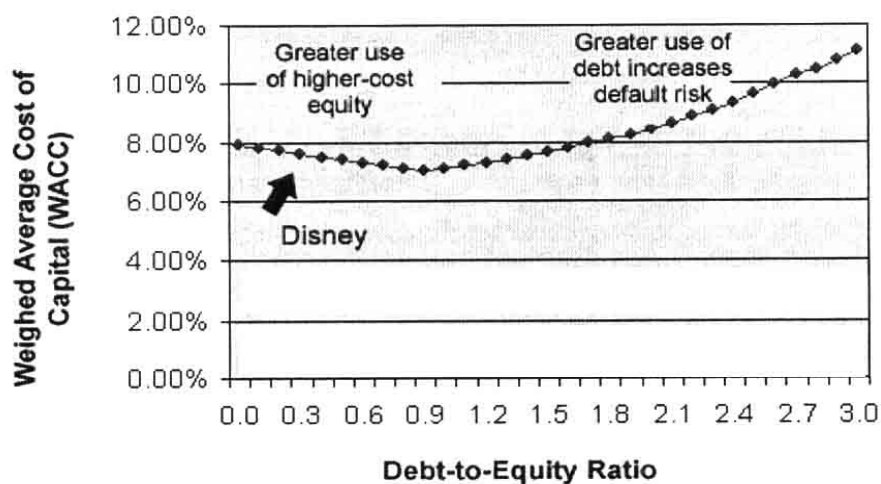

### 2.5.10 The EVA

We now have all of the elements to perform the final EVA calculation, which is the subtraction of a capital charge from NOPAT. The capital charge is invested capital multiplied by WACC (a percentage). This is all shown below:

W & D Company

Particulars	Amount (₹)
Net Operating Profit After Tax (NOPAT)	3,597
Invested Capital x WACC ( 58950 × 7.4% ) =	
<b>Capital Charge</b>	4,362
<b>EVA ( NOPAT – Capital charge)</b>	(765)

The EVA number tells us that, despite generating ₹ 3.597 billion in after-tax net operating profits, W & D did not quite cover its cost of capital. Of course, it fully serviced its debt, but the point of economic profit is to charge the company for the use of equity capital – when we incorporate this cost, we find that Disney lost (some would say “destroyed value”) ₹ 765 million in economic profits.

### What Does Economic Value Added Really Mean?

Now that you've viewed economic profit in action, you've likely observed that most of its perceived complexity results from *two types of adjustments* that convert accounting earnings into Net Operating Profit After Tax (NOPAT). The goal of these adjustments is to translate an accounting profit into an economic profit that more accurately reflects cash invested and cash generated. The illustration below recaps the process.

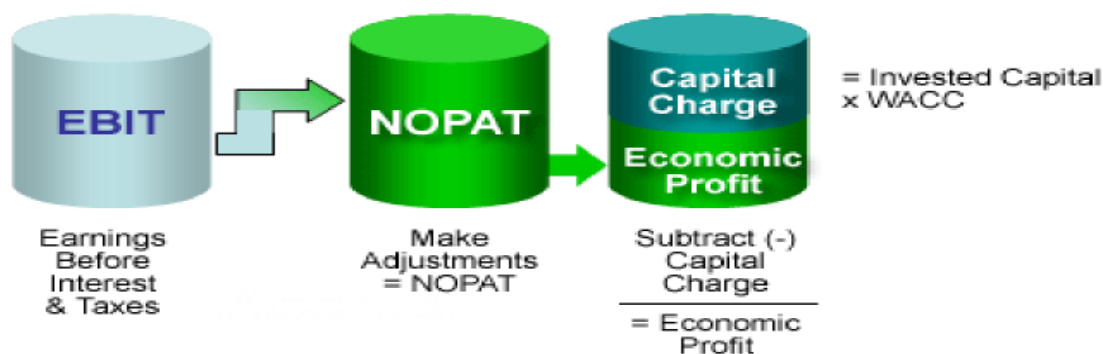

Copyright © 2005 Investopedia.com

To make the conversion, we can start with any income statement line, but it is easiest to start with **earnings before interest and taxes (EBIT)**. Then we make two types of adjustments in order to convert EBIT into NOPAT. First, we reverse **accruals** to capture cash flows, and second, we **capitalize** expenses that ought to be treated like investments. Once we have NOPAT, we need only to subtract the capital charge, which is equal to total invested capital - which we find by making appropriate adjustments to invested book capital, found on the balance sheet - multiplied by the **weighted average cost of capital (WACC)**.

### The Core Adjustments

Remember the importance of being consistent throughout the course of your calculations: always match an income statement adjustment - in getting NOPAT - to a corresponding balance sheet adjustment - in getting invested capital. This is more important than the number of your adjustments!

The “perfect” economic profit calculation is fully loaded; that is, it captures every rupees of invested capital and makes every adjustment to determine the precise level of **cash flow**. But the need for a perfect economic profit number is questionable. Many academic studies have demonstrated that the incremental information gained beyond a handful of key adjustments is minimal. You are therefore okay to use a few adjustments to arrive at an approximation.

The table below shows a list of selected core adjustments. Each income statement adjustment in the left-hand column helps to convert EBIT to NOPAT; each corresponding balance sheet adjustment in the right-hand column helps convert book capital to invested capital.



Income Statement Adjustment (EBIT → NOPAT)	Balance Sheet Adjustment (Book Capital → NOPAT)
Add: Increase in LIFO Reserve	Add: LIFO Reserve
Add: Increase in allowance for bad debt	Add: Bad debt Reserve
Add: Implied Interest on Operating Lease	Add: Present value of future operating lease obligations.
Add: Increase in capitalized research & development (R&D) costs	Add: Capitalized R&D Investment
Add: Minority Interest provision (if not already included)	Add: Minority Interest
Add: Increase in deferred income tax reserve	Add: deferred tax liability

### Let us now illustrate another example

Sriram computers; an export oriented firm in software. Sriram Computers had Profit Before Tax of ₹70.00 crore during F.Y. 2012–13. The tax obligation was nominal ₹5.00 crore being 100% export unit exempt from tax. The firm had average debt of ₹200.00 crore (60% of capital employed) with an interest outgo of ₹30.00 crore. NOPAT was derived as below:

#### Step 1 : Arriving at NOPAT

Particulars	(₹ crore)
Profit Before Tax	70.00
Less: Taxes	5.00
Add: Actual Interest	30.00
NOPAT	95.00

**Note that** while arriving at NOPAT the tax shield of interest must be subtracted. Since Sriram had no tax (small outgo of tax of ₹5.00 due to other reasons notwithstanding) due to its export status, it had no tax shield available and therefore no adjustment is made.

NOPAT can also be equated as  $EBIT \times (1 - \text{tax rate})$ , and EVA can be state as:

$EBIT \times (1 - \text{Tax rate}) - \text{Capital Employed} \times \text{WACC}$

#### Step 2: Computing Weighted Average Cost of Capital

Particulars	(₹ crore)
Assumed rate of risk free return	12.08%
Expected Risk Premium on Equity (for Software exporters)	10.00%
Beta Variant of Sriram	1.215
Cost of Equity (Using CAPM) = $(12.08 + 1.215 \times 10)$	24.23%
WACC for Sriram = $24.23\% \times 0.40 + 15.00\% \times 0.60$	18.70%
Capital Employed = $\frac{\text{Debt}}{\text{debt ratio}} = \frac{200}{0.60}$	₹333.33 crore

$$\begin{aligned}\text{Equity} &= \text{Capital employed} \times \text{Equity ratio} \\ &= 333.33 \times 0.40 = ₹133.33 \text{ crore}\end{aligned}$$

$$\text{Cost of capital (18.70\%} \times 333.33) = ₹62.33 \text{ crore}$$

Here again note that we have considered cost of debt at 15% the actual cost born by the firm. While computing WACC we must take after tax cost of debt. Since Sriram was tax exempt, pre-tax cost as well as post-tax cost of debt will be same.

Cost of equity has been arrived at by CAPM model with the assumed risk free rate of 12.08% and a risk premium of 10%. The observed beta of Sriram for the period was 1.215.

### Step 3: Finding EVA

$$\text{EVA} = \text{NOPAT} - \text{Cost of capital}$$

$$= 95.00 - 62.33 = ₹32.67 \text{ crore}$$

The EVA of ₹32.67 crore implies that during the year 2012-13 the firm added economic value of ₹32.67 crore, i.e., it earned a return of ₹32.67 crore after providing for the cost of the capital. Thus, the firm was a value creator. If this figure is negative, the firm would be termed as value destroyer.

Computation of EVA for another firm, Dewan Ltd. is shown as follows:

	2013	2012	2011	2010	2009
<b>Cost of Capital</b>					
Risk-free rate (%)	6.80	5.20	6.00	7.30	10.30
Market premium (%)	7.00	7.00	7.00	7.00	7.00
Beta Variant	1.00	1.20	1.50	1.40	1.60
<b>Cost of equity(%)</b>	<b>13.80</b>	<b>13.60</b>	<b>16.50</b>	<b>17.10</b>	<b>21.50</b>
Debt	-	-	-	-	-
Cost of Debt	-	-	-	-	-
<b>WACC (%)</b>	<b>13.80</b>	<b>13.60</b>	<b>16.50</b>	<b>17.10</b>	<b>21.50</b>
Average capital employed	4,330.00	3,120.00	2,490.00	1,730.00	1,110.00
<b>Economic Value Added</b>					
Operating profit (excluding extra-ordinary income)	2,050.00	1,350.00	1,070.00	950.00	700.00
Less: Tax	615.00	405.00	321.00	285.00	210.00
Less: Cost of Capital	597.54	424.32	410.85	295.83	238.65
<b>Economic Value Added</b>	<b>837.46</b>	<b>520.68</b>	<b>338.15</b>	<b>369.17</b>	<b>251.35</b>

### 2.5.11 Steps in Implementing EVA

The implementation of EVA is a four stepped process which include: (a) Measurement, (b) Management System, (c) Motivation, and (d) Mindset.

- Measurement** – Any company that wishes to implement EVA should institutionalize the process of measuring the metric, regularly. This measurement should be carried out after carrying out the prescribed accounting adjustments.
- Managements System** – The company should be willing to align its management system to the EVA process. The EVA based management system is the basis on which the company should take decision related to the choice of strategy, capital allocation, merger and acquisitions, divesting business and goal setting.

- (c) **Motivation** – The company should decide to implement EVA only if it is prepared to implement the incentive plan that goes with it. An EVA based incentive system, however, encourages managers to operate in such a way as to maximize the EVA, not just of the operations it oversees but of the company as whole.
- (d) **Mindset** – The effective implementation of EVA necessitates a change in the culture and mindset of the company. All constituents of the organization need to be taught to focus on one objective-maximizing EVA. This singular focus leaves no room for ambiguity and also it is not difficult for employees to know just what actions of their will create EVA, and what will destroy it.

### 2.5.12 Different Ways to Improve EVA

There are three variables that determine the EVA:

- (1) Net operating profit after taxes (NOPAT)
- (2) Weighted average cost of capital (WACC)
- (3) Total capital employed

The EVA of the firm will improve with increased earnings for same levels of cost and capital employed. The EVA will also increase if the same level of earnings is maintained with reduced cost or lesser capital. The broad strategies for enhancing EVA can be put in following three categories:

- (1) **Process improvements:** It focuses on increasing the efficiency of operations, thereby increasing the spread between the returns on capital employed and cost of capital. This includes better management of net working capital.
- (2) **Exploiting growth potential:** This denotes increasing the total capital employed by undertaking all positive NPV projects; since the spread between returns and cost of capital is positive it will enhance EVA.
- (3) **Managing assets and restructuring:** This emphasises on decreasing the exposure from the projects that are not yielding returns in excess of cost of capital. MVA at any point of time is equal to the discounted present value of all the EVA. If the market and investors can accurately foresee all the potential of the firm, EVA and MVA will be identical.

### 2.5.13 Limitation of EVA

Though EVA represents a novel approach to assess a value the firm creates, many believe that it is no different than the residual income approach. It merely states the excess profits over WACC, which has been underlying theme in all capital budgeting and valuation concepts. Hence, EVA is an addition to the dictionary of finance, which has many synonyms already existing. The underlying concept is not substantially different than the used in the valuation exercise by analysts.

Not only disputing its novelty, some of them may find the EVA approach as self-defeating in the sense that its computation starts from accounting profits only. As discussed earlier the cash flows of the firm are considered to be the main driver of the value of the firm. Due to the distortion, the accounting profits have for the cash flows, adjustments are required to be made for cash flows. Emphasis on NOPAT seems a contradiction to cash flows as basic determinant of value especially in regard to treatment of depreciation. The markets are intelligent to arrive at real cash flows from the accounting profit. Markets intuitively account for it through P/E Ratios, and do not need another measure of value. The collective judgment of value by the market is deemed superior to the complex computation of EVA.

In any case, the lack of financial disclosures and accounting adjustments of various expense and revenue items that are not consistent and uniform across firms, make the computation of EVA difficult. The accuracy of calculation will always remain a suspect due to inadequate disclosures.

Another problem that the EVA faces is with regard to its use as a measure of comparative performance. As different firms have different capital structures and different costs of capital, two firms in the same

line of business with same level of profit will have a different EVA depending upon the cost of capital. The one with lesser cost of capital due to the use of higher debt will show a greater EVA. Here the value is driven increased financial leverage and not by more efficient utilization of assets, the parameter EVA is supposed to measure. Faced with the same business risk and same level of profit the two firms must rank equal. To overcome it may be suggested to use a single WACC which could be an industry average to assess the EVA of the firms in the same business line.

Again, the EVA is not comparable across industries due to differing efficiencies of capital in different industries. Capital intensive projects would reflect lower EVA as compared to its true potential, and as compared to firms engaged in projects of small capital such as trading activities and consumer products.

#### 2.5.14 Residual Income

Residual income is based on the concept of economic profit, but it relies closely on accounting conventions for both income and value calculations. Residual income is defined as:

Residual income = Earnings – Cost of capital

where, the cost of capital is the product of the cost of equity,  $r$ , and the book value of equity at the beginning of the period,  $B_{t-1}$ :

Cost of capital =  $r \times B_{t-1}$

Let  $E_t$  represent the earnings for period  $t$ , then the value of equity today,  $V_0$ , is:

$$V_0 = B_0 + \sum_{t=1}^{\infty} \frac{E_t - rB_{t-1}}{(1+r)^t}$$

The key to residual income is the relation between the ability of the firm to generate residual income and its cost of equity: the firm creates value from residual income as long as it can generate return in excess of its cost of equity.

#### 2.5.15 Assumptions

Like a dividend valuation model or any other cash flow model of valuation, there are different assumptions that can be made regarding residual income in the future. An analyst could characterize a firm's future residual income as constant, growing constantly, growing at different rates depending on the period in the future, or converging upon zero. The latter is likely the most reasonable regarding residual income because it is generally the case that a firm can maintain a comparative or competitive advantage in the short-term, but in the long term the return that a company can earn converges upon a normal level – hence, no economic profits.

Consider an example in which a company has a cost of equity of 10 percent and a current book value of equity of ₹100 million. If the company has a current return on equity of 15 percent, but this return on equity is expected to decline linearly so that the company earns its cost of equity after five years,

1. What is its residual income for each year?
2. What is the value of its equity?

The calculations are as follows:

Year	Beginning period book value of equity $B_{t-1}$	Return on equity ROE	Earnings based on ROE $E_t$	Cost of capital in monetary terms $r \times B_{t-1}$	Residual income $E_t - rB_{t-1}$	$(1+r)^t$	Present value
1	100.0000	15%	15.0000	10.0000	5.0000	1.1000	1.0450
2	115.0000	14%	16.1000	11.5000	4.5000	1.2100	3.7190
3	131.1000	13%	17.0430	13.1000	3.9430	1.3310	2.9620
4	148.1430	12%	17.7772	14.8143	2.9629	1.4641	2.0370
5	165.9202	11%	18.2512	16.5920	1.6592	1.6105	1.0302
6	184.1714	10%	18.4171	18.5171	0		0.0000
Sum							10.7932
Add $B_0$							100.0000
$V_0$							110.7932

Therefore, the present value of residual income is ₹ 10.7932 million which, when added to the current book value, results in a value of equity of ₹110.7932 million.

How is this different than economic value added? Economic value added is calculated using the cost of capital for the firm, the market value of equity, and operating income, whereas residual income is calculated using the cost of equity, the book value of equity, and net income. But are these differences significant? It depends on a number of factors, including:

1. Whether the book value of equity is a good representation of the value of equity without future opportunities incorporated, and
2. Whether the accounting net income is an adequate measure of period performance.

## CASE STUDY

### 1. EVA Based Performance Management: A Case Study of SBI and HDFC Bank

#### Introduction

Economic Value Added. EVA for short is primarily a benchmark to measure earnings efficiency. Though the term "Economic Profit" was very much there since the inception of "Economics". Stern Stewart & Co., of USA has got a registered Trade Mark for this by the name "EVA". An acronym for Economic Value Added. EVA as a residual income measure of financial performance is simply the operating profit after tax less a charge for the capital, equity as well as debt, used in the business. Because EVA includes profit and loss as well as balance sheet efficiency as well as opportunity cost of investor capital-it is better linked to changes in shareholder wealth and is superior to traditional financial metrics such as PAT or percentage rate of return measures such as ROCE or ROE. In addition EVA is a management tool to focus managers on the impact of their decisions in increasing shareholder wealth. These include both strategic decisions such as what investments to make, which business to exist, what financing structure is optimal as well as operational decisions involving trade-offs between profit and asset efficiency such as whether to make in house or outsource, repair or replace a piece of equipment, whether to make short or long production runs etc.

Most importantly the real key to increasing shareholder wealth is to integrate the EVA framework in four key areas: to measure business performance : to guide managerial decision making : business literacy throughout the organization. To better align managers interests with Shareholders- the EVA framework needs to be holistically applied in an integrated approach- simply measuring EVA is not enough it must also become the basis of key management decisions as well as be linked to senior management's variable compensation.



### Calculation of EVA

Just earning profit is not enough. a business should earn sufficient profit to cover its cost of capital and create surplus to grow, Stated simply, any profit earned over and above the cost of capital is Economic Value Added. Traditionally the methods of measurement of corporate performance are many. Common bases used are: - Net Profit Margin (NPM), Operating Profit Margin (OPM). Return on Investment (ROI), Return on Net Worth (RONW) etc. Profit After Tax (PAT) is an indicator of profit available to the shareholder and Profit Before Interest After Tax [PBIAT) is an indicator of the surplus generated using total funds. ROI is still recognized as the most popular yardstick of profitability measurement. However, the traditionally used profit indicators are ineffective parameters in explaining whether the reported profit covers the cost of capital. Old profit concept fails to indicate clear surplus. The basic proposition is that the Return on Capital Employed should be greater than the Cost of Capital (i.e. ROCE > KO). Capital Employed highlights long term capital and cost of capital represents weighted average cost of capital.

Traditionally, Profit after Tax is shown in the Profit & Loss Account to indicate the profit available to the shareholders, both preference and equity. Ability to maintain dividend is not a test of profit adequacy. Ability to generate Economic Value Added is the only test of profit adequacy. Any surplus generated from operating activities over and above the cost of capital is termed as EVA. It is a new measure of corporate surplus that should be shared by the employees, management and shareholders. EVA focuses on clear surplus in contradiction to the traditionally used profit available to the shareholders. It is used by companies as a performance indicator and also as a basis for executive compensation. Surplus should be derived by deducting cost of capital from profit before interest but after tax.

#### **EVA = NOPAT – WACC x Capital Employed.**

Where, NOPAT means Net Operating Profit before Interest and after Tax.

WACC represents Weighted Average Cost of Capital.

Capital Employed = Net Block + Trading Investment + Net Current Assets.

It is free from subjective assumption that needs to be adopted while identifying profit and cost of capital. Cost of equity is derived on the basis of Capital Assets Pricing Model (CAPM). The founders of EVA traditionally use CAPM. Under CAPM Cost of Equity ( $K_e$ ) is given by the following:-

$$K_e = R_f + \beta(R_m - R_f)$$

Where,  $R_f$  = Risk free return.

$R_m$  = Market expected Rate of Return

$\beta$  = Risk Co-efficient.

Both market return and Beta are highly volatile, and if annual market return and yearly beta of a company are chosen for finding cost of equity, abnormally high or low market related cost of equity may be obtained. To avoid this difficulty, one may apply "Long run approach". While deriving EVA it becomes necessary to make certain accounting adjustments, which are required only for corporate reporting purposes. It is sometimes alleged that EVA talks too much about the shareholders value added rather than focusing on the interest of all stakeholders. But EVA is a powerful performance measurement tool and it is argued that if a company is able to serve its shareholders then it can better serve all other stakeholders also.

#### **Benefits of EVA for Banks**

As banks become 'capital hungry' to meet their growth expectations and simultaneously meeting the regulatory requirements in the Basel-II era, they would have to remain responsive to the expectations of the market on a risk adjusted basis to ensure continued supply of financial capital from the shareholders and human capital from the ultimate stakeholders. One of the fundamental limitations in the existing business growth strategies of Indian banks, especially public sector banks, is its virtual, if not complete,



disconnect with riskiness. 'Profit rich but Risk poor' strategies are doomed for failure in the long-run! Finalization of business targets should no longer remain a mundane 'volume-mix' targeting exercise but should built-in inherent risk-return dimensions. Business strategies that ensure 'Risk & Return by Choice and not by Chance' are key to ensure continuing success of banks in the emerging market. In order to align the performance of individual zones/regions/branches to the overall corporate expectations in terms of EVA, the vocabulary of risk management has to percolate down the hierarchy of banks to the individual unit level. New performance benchmarks in the form of EVA should naturally form the unifying cord/link in every bank. EVA can be all important tool that bankers can use to measure and improve the financial performance of their bank. Since EVA takes the interest of the bank's shareholders into consideration, the use of EVA by bank management may lead to different decisions than if management relied solely on other measures. As mentioned earlier an important difference between banks and others is the role of debt. For other firms debt is a part of the financing operations and interest expenses are excluded from Net Operating Profit After Taxes (NOPAT) so that returns are unlevered. A bank's debt funding is effectively the raw material which is intermediated into higher yielding assets. Interest expense on this view, is equivalent of the cost of goods sold. This has an important consequence. In our analysis NOPAT for each year was therefore arrived at after adding interest on RBI loans and other loans to Profit before Depreciation and Taxes less Cash Taxes. The component of cash taxes represented as if banks were debt free. In order to calculate cash taxes, tax shield on the interest paid on RBI loans and others were added back to Tax Provision and tax paid on other incomes were deducted from tax provision of the year. A tax rate of 30 percent per year was assumed for maintaining consistency over years in our analysis. The economic capital of a bank is defined as the shareholders funds plus reserves excluded from equity, such as loan losses or contingency reserve which in economic terms function as capital. In this fund total long term borrowings of the bank are added to arrive at the Invested Capital (IC). In our analysis we have first attempted to critically evaluate bank's performance in generating Return on Invested Capital (ROIC) over years. We have taken two most critical indicators viz. Return on Invested Capital (ROIC) and Incremental ROIC.

### **EVA a Superior Performance Measure**

First let us look into the claim of EVA being superior- than the conventional measures such as ROI, ROE and ROA, which are based on the accounting figures. Most of these measures give us the rate of return earned by the bank with respect to capital invested in the bank. The most important limitation of these measures is derived from limitations inherent in the measurement of accounting profit. As per current accounting practices, while historical-cost-based accounting measures are being used to carry most of the assets in the balance sheet, revenue and expenses (other than depreciation) are recognized in the Profit and Loss Account at their current value. Therefore accounting rate of returns do not reflect the true return from an investment and tend to be biased downwards in the 10 initial years and upwards in the latter years. Similarly as noted by Malkelainen (Esa Malkelainen 1998), distortion occurs basically due to the historical cost and straight line depreciation schedule used by most businesses to value their assets. This leads to a bias in these measures due to the composition of assets of a bank at any given point in time. By composition he refers to the current nature of the assets. More current the assets are, the accounting rate of return is closer to the true rate of return. This distortion will not be significant if there is a continuous stream of investments in assets i.e. the value of the mix of assets is nearer to the current value of the assets. But the probability, that at any point of time, a bank should have such a composition of assets is rare. In most cases either the assets are old or relatively new. This precludes these accounting measures from being used to reach any meaningful conclusion regarding the true performance of the bank. The other important limitation of accounting measures is that they ignore the cost of equity and only consider the borrowing cost. As a result it ignores the risk inherent in the project and fails to highlight whether the return is commensurate with the risk of the underlying assets. This might result in selecting projects that produce attractive rate of return but destroys bank value because their cost of capital is higher than the benchmark return established by the management. On the other hand accounting measures encourage managers to select projects that will improve the current rate of return and to ignore projects even if their return is higher than their cost of capital.

Selection of projects with returns higher than the current rate of return does not automatically increase shareholders' wealth. Taking up only those projects, which provide returns that are higher than the hurdle rate (cost of capital) results in increasing the wealth of the shareholder. Therefore use of ROE, ROA or similar accounting measures as the benchmark, might result in selection of those projects that though provide rate of return higher than the current rate of return destroys bank-value. Similarly use of these measures result in continuing with activities that destroys bank value until the rate of return falls below the benchmark rate of return.

EVA proponents claim that because of these imperfections, the accounting based measures are not good proxies for value creation. Managerial compensation based on *these measures* does not encourage value enhancement actions by managers. Value enhancement and earnings are two different things and might be at cross-purposes because short-term performance might be improved at the cost of long term health of the bank. Activities involving enhancement of current earnings may be short term in nature. Whereas any value enhancing activities should focus on long term well being of the bank.

Avoidance of discretionary costs improves current performance while destroying value of the bank. The question arises whether EVA is an improvement over conventional measures and serves the purpose of motivating managers to pay attention to shareholders value even if that results in compromising current performance. The answer may be negative because all the above limitations are also associated with EVA. As shown in equation, the calculation of EVA entails the usage of an accounting rate of return. The difference lies only in the fact that the cost of equity is also factored in to arrive at the residual income figure. Though incorporation of the cost of equity capital is the virtue of EVA. Because it measures economic surplus. It does not remove the limitations of the accounting profit that forms the basis for computing EVA. Moreover the virtue might not be realized in practice since it is not easy to calculate the cost of equity. Market returns cannot be used as a proxy for cost of equity that supports assets in place because market discounts the expectations. Similarly it is difficult to use CAPM in measuring cost of equity because it is difficult to measure risk-free-rate of return, beta and market premium. Difficulties get compounded in an economic environment like India, where interest rates fluctuate frequently. The capital market is volatile and the regulators are yet to have a complete grip on the capital market to enhance its efficiency. Empirical studies show that the volatility in the Indian capital markets, like capital markets in other developing economies, is higher than capital markets in developed economies. Therefore even if for the sake of argument it can be said that the potential of EVA as a measure of performance can be realized fully in an advanced economy. The argument that EVA is a better measure is not tenable in the Indian context.

The study is mainly based on secondary data, all the data of two Indian public and private sector banks i.e. SBI and HDFC Bank that are listed on the National Stock Exchange are collected from respective annual reports, publications of RBI and from the various websites. The data from the reports have been analyzed by using various tools and techniques with a view to evaluate the performance of the banks. The calculation is the indicator of overall analysis of two bank's financial performance for the period of 2005-06 to 2007-08.

### **DATA ANALYSIS AND INTERPRETATION**

#### **Net Operating Profit after Tax (NOPAT)**

The NOPAT curriculum includes Interest Income, Other Income deducting interest on deposit and other operating expenses less tax so as to give an overall emphasis for Operating Profit. Net Operating Profit is considered instead of Net Profit so as to highlight the economic value of a firm.

(Net Profit + Provisions and contingencies + Interest on Borrowings) less (Taxes)

### Net Operating Profit

Banks/Years	2007-08	2006-07	2005-06
SBI	17963	13478	14058
HDFC	4269	3048	2348

### Tax

Banks/Years	2007-08	2006-07	2005-06
SBI	5389	4043	4217
HDFC	1281	914	704

### NOPAT

Banks/Years	2007-08	2006-07	2005-06
SBI	12574	9435	9841
HDFC	2988	2134	1644

### Incremental NOPAT

The Incremental NOPAT shows the change in the overall NOPAT in the year 2007-08 when compared to 2006-07.

### NOPAT (t) – NOPAT (t-1)

#### Incremental NOPAT

Banks/Years	2007-08	2006-07
SBI	3139	-406
HDFC	854	490

### Invested Capital

The invested capital includes Total Equity and Reserves and borrowings excluding Total Deposits because these are the prime essentials for undermining the operations of a business unit.

Total equity & Reserves + Total borrowings

#### Invested capital

Banks/Years	2007-08	2006-07	2005-06
SBI	1 00760	71002	58285
HDFC	15976	9248	8158

### Incremental Invested Capital

The incremental Invested capital determines the overall change in the invested capital as compared to the previous year.

Invested capital (t) - Invested Capital (t-1)

Incremental Invested Capital

Banks/Years	2007-08	2006-07
SBI	29758	12717
HDFC	6728	1090

**Return on Invested Capital (ROIC)**

The return on invested capital signifies the return that the firm earns on the capital invested for a given period of time.

NOPAT / Invested Capital

**Return on Invested Capital**

Banks/Years	2007-08	
	NOPAT	Capital employed
SBI	12574	100760
HDFC	2988	15976
Banks/Years	2006-07	
	NOPAT	Capital employed
SBI	9435	71002
HDFC	2134	9248
Banks/Years	2005-06	
	NOPAT	Capital employed
SBI	9841	58285
HDFC	1644	8158

ROIC

Banks/Years	2007-08	2006-07	2005-06
SBI	0.12	0.13	0.17
HDFC	0.19	0.23	0.20

**Beta( $\beta$ )**

Beta can be defined as a risk measuring factor for different capital allotments. Higher the Beta, higher the risk. Beta here has been calculated based on stock prices vis a vis NIFTY for each year separately.

$$n \sum xy - (\sum x) (\sum y) \div n \sum x^2 - (\sum x)^2$$

**BETA ( $\beta$ )**

Banks/Years	2007-08	2006-07	2005-06
SBI	0.91	1.22	1.10
HDFC	0.93	1.22	1.03

2007-2008	NIFTY (X)			HDFC (Y)			X <sup>2</sup>	XY	BETA (b)
	CLOSING PRICE	CHANGE (Rs.)	CHANGE (%)	CLOSING PRICE	CHANGE (Rs.)	CHANGE (%)			
Mar	3,821.55			942.47					0.93
Apr	4,087.90	266.35	6.97	1,011.61	69.14	7.34	48.58	51.13	
May	4,295.80	207.90	5.09	1,141.27	129.66	12.82	25.86	65.18	
Jun	4,318.30	22.50	0.52	1,140.42	-0.85	-0.07	0.27	-0.04	
Jul	4,528.85	210.55	4.88	1,193.97	53.55	4.70	23.77	22.89	
Aug	4,464.00	-64.85	-1.43	1,163.54	-30.43	-2.55	2.05	3.65	
Sep	5,021.35	557.35	12.49	1,428.07	264.53	22.73	155.89	283.86	
Oct	5,900.65	879.30	17.51	1,657.80	229.73	16.09	306.64	281.70	
Nov	5,762.75	-137.90	-2.34	1,708.52	50.72	3.06	5.46	-7.15	
Dec	6,138.60	375.85	6.52	1,707.47	-1.05	-0.06	42.54	-0.40	
Jan	5,137.45	-1,001.15	-16.31	1,541.44	-166.03	-9.72	265.99	158.59	
Feb	5,223.50	86.05	1.67	1,440.80	-100.64	-6.53	2.81	-10.94	
Mar	4,734.50	-489.00	-9.36	1,312.71	-128.09	-8.89	87.64	83.23	
Σ			26.21			38.90	967.50	931.70	
2006-2007	NIFTY (X)			HDFC (Y)			X <sup>2</sup>	XY	BETA (b)
	CLOSING PRICE	CHANGE (Rs.)	CHANGE (%)	CLOSING PRICE	CHANGE (Rs.)	CHANGE (%)			
Mar	3,402.55			759.94					1.22
Apr	3,508.10	105.55	3.10	808.97	49.03	6.45	9.62	20.01	
May	3,185.30	-322.80	-9.20	740.92	-68.05	-8.41	84.67	77.40	
Jun	3,128.20	-57.10	-1.79	786.21	45.29	6.11	3.21	-10.96	
Jul	3,143.20	15.00	0.48	785.27	-0.94	-0.12	0.23	-0.06	
Aug	3,413.90	270.70	8.61	841.62	56.35	7.18	74.17	61.80	
Sep	3,588.40	174.50	5.11	914.02	72.40	8.60	26.13	43.97	
Oct	3,744.10	155.70	4.34	992.3	78.28	8.56	18.83	37.16	
Nov	3,954.50	210.40	5.62	1,108.07	115.77	11.67	31.58	65.56	
Dec	3,966.40	11.90	0.30	1,054.88	-53.19	-4.80	0.09	-1.44	
Jan	4,082.70	116.30	2.93	1,065.40	10.52	1.00	8.60	2.92	
Feb	3,745.30	-337.40	-8.26	923.55	-141.85	-13.31	68.30	110.03	
Mar	3,821.55	76.25	2.04	942.47	18.92	2.05	4.14	4.17	
Σ			13.27			24.97	329.57	410.58	
2005-2006	NIFTY (X)			HDFC (Y)			X <sup>2</sup>	XY	BETA (b)
	CLOSING PRICE	CHANGE (Rs.)	CHANGE (%)	CLOSING PRICE	CHANGE (Rs.)	CHANGE (%)			
Apr	1,902.50			520.74					1.03
May	2,087.55	185.05	9.73	529.58	8.84	1.70	94.61	16.51	
Jun	2,220.60	133.05	6.37	624.3	94.72	17.89	40.62	114.00	
Jul	2,312.30	91.70	4.13	686.52	62.22	9.97	17.05	41.16	
Aug	2,384.65	72.35	3.13	628.42	-58.10	-8.46	9.79	-26.48	
Sep	2,601.40	216.75	9.09	672.49	44.07	7.01	82.62	63.74	
Oct	2,370.95	-230.45	-8.86	595.44	-77.05	-11.46	78.48	101.50	
Nov	2,652.25	281.30	11.86	674.21	78.77	13.23	140.76	156.95	
Dec	2,836.55	184.30	6.95	695.65	21.44	3.18	48.29	22.10	
Jan	3,001.10	164.55	5.80	748.36	52.71	7.58	33.65	43.96	
Feb	3,074.70	73.60	2.45	723.53	-24.83	-3.32	6.01	-8.14	
Mar	3,402.55	327.85	10.66	759.94	36.41	5.03	113.70	53.66	
Σ			61.32			42.34	665.58	578.95	

**Cost of Equity ( $K_e$ )**

It determines the expected rate of return for the investors. We have calculated the cost of equity for the following banks using CAPM model and taking inputs such as  $R_f$  (365 days T-bills rate -same for each year i.e. 4.55%),  $R_m$  (3 years market monthly return of NIFTY) and  $b$ .

$$R_f + \beta(R_m - R_f)$$

<b>2007-08</b>	<b>Closing Price</b>	<b>Change</b>	<b>Change (%)</b>
Mar - 07	3,821.55		
April - 07	4,087.90	266.35	6.97
May - 07	4,295.80	207.90	5.09
June - 07	4,318.30	22.50	0.52
July - 07	4,528.85	210.55	4.88
Aug - 07	4,464.00	-64.85	-1.43
Sep - 07	5,021.35	557.35	12.49
Oct - 07	5,900.65	879.30	17.51
Nov - 07	5,762.75	-137.90	-2.34
Dec - 07	6,138.60	375.85	6.52
Jan - 08	5,137.45	-1,001.15	-16.31
Feb - 08	5,223.50	86.05	1.67
Mar - 08	4,734.50	-489.00	-9.36

$$R_m = 2.18 \quad K_e(\text{SBI}) = 6.7 \quad K_e(\text{HDFC}) = 6.75$$

<b>2006-07</b>	<b>Closing Price</b>	<b>Change</b>	<b>Change (%)</b>
Mar - 06	3,402.55		
April - 06	3,508.10	105.55	3.1
May - 06	3,185.30	-322.80	-9.2
June - 06	3,128.20	-57.10	-1.79
July - 06	3,143.20	15	0.48
Aug - 06	3,413.90	270.70	8.61
Sep - 06	3,588.40	174.50	5.11
Oct - 06	3,744.10	155.70	4.34
Nov - 06	3,954.50	210.40	5.62
Dec - 06	3,966.40	11.90	0.3
Jan - 07	4,082.70	116.30	2.93
Feb - 07	3,745.30	-337.40	-8.26
Mar - 07	3,821.55	76.25	2.04

$$R_m = 1.11 \quad K_e(\text{SBI}) = 8.75 \quad K_e(\text{HDFC}) = 8.75$$

<b>2005-06</b>	<b>Closing Price</b>	<b>Change</b>	<b>Change (%)</b>
Mar - 05	1,902.50		
April - 05	2,087.55	185.05	9.73
May - 05	2,220.60	133.05	6.37



June - 05	2,312.30	91.7	4.13
July - 05	2,384.65	72.35	3.13
Aug - 05	2,601.40	216.75	9.09
Sep - 05	2,370.95	-230.45	-8.86
Oct - 05	2,652.25	281.30	11.86
Nov - 05	2,836.55	184.30	6.95
Dec - 05	3,001.10	164.55	5.8
Jan - 06	3,074.70	73.60	2.45
Feb - 06	3,402.55	327.85	10.66
Mar - 06	1,902.50	185.05	9.73

$R_m = 5.57$ ,  $K_e(\text{SBI}) = 3.42$ ,  $K_e(\text{HDFC}) = 3.49$

### Cost of Debt (Kd)

It can be defined as the total interest paid divided by the total borrowings by a firm. (Total Interest Expense - Interest on Deposit) / Total Borrowings

Bank/ Year	2007-08		2006-07		2005-06	
	Interest Paid	borrowings	Interest Paid	borrowings	Interest Paid	borrowings
SBI	4856	51727	3479	39703	2758	30641
HDFC	504.39	4478.86	484.13	2815.39	30.07	2858.48
Kd (SBI)	0.065120419		0.061344821		0.063	
Kd (HDFC)	0.078830997		0.12037089		0.090624738	

### Weighted Average Cost of Capital (WACOC)

The Weighted Average Cost of Capital (WACOC) is the minimum rate of return on capital required to compensate debt and equity investors for bearing risk.

Weighted cost of Equity ÷ Weighted cost of Debt

Banks/ Years	Cost of Equity			Cost of Debt		
	2007-08	2006-07	2005-06	2007-08	2006-07	2005-06
SBI	0.0670	0.0875	0.0342	0.0657	0.0613	0.0630
HDFC	0.0675	0.0875	0.0349	0.0788	0.1204	0.0906
	Weight of Equity			Weight of Debt		
SBI	0.49	0.44	0.47	0.51	0.56	0.53
HDFC	0.72	0.7	0.65	0.28	0.30	0.35

### Capital Charge

Capital Charge is the total cost of the bank to pay interest and dividend for fulfilling the criteria's of equity holders and debt-borrowers.

Cost Of Capital x Capital Invested



Banks	WACC	Capital Invested	Capital Charge
<b>2007-08</b>			
SBI	0.066337	1,00,760	6,684
HDFC	0.070664	15,976	1,129
<b>2006-07</b>			
SBI	0.049464	71,002	3,512
HDFC	0.054395	9,248	503
<b>2005-06</b>			
SBI	0.034328	58,285	2,001
HDFC	0.03612	8,158	295

**Economic Value Added (%)**

(EVA – As a measure of value creation through Management of Profits)

Economic Value Added Statement of SBI

Particulars / Years	2007-08	2006-07	2005-06
Average Capital Employed	15,976	9,248	8,158
Weight of Debt	0.28	0.30	0.35
Weight of Equity	0.72	0.70	0.65
Beta ( $\beta$ )	0.93	1.22	1.03
Risk free rate ( $R_f$ )	4.55%	4.55%	4.55%
Market Risk Premium ( $R_m$ )	2.18	1.11	5.57
Cost of equity ( $K_e$ )	6.75	8.75	3.49
Cost of debt ( $K_d$ )	0.078830997	0.12037089	0.090624738
WACOC	0.070664	0.054395	0.03612
ROIC (NOPAT/ CAP EMPLOYED)	0.19	0.23	0.20
EVA (ROIC- WACOC)	0.1193	0.1756	0.1639

Economic Value Added Statement of HDFC

Particulars / Years	2007-08	2006-07	2005-06
Average Capital Employed	1,00,760	71,002	58,285
Weight of Debt	0.51	0.56	0.53
Weight of Equity	0.49	0.44	0.47
Beta ( $\beta$ )	0.91	1.22	1.1
Risk free rate ( $R_f$ )	4.55%	4.55%	4.55%
Market Risk Premium ( $R_m$ )	2.18	1.11	5.57
Cost of equity ( $K_e$ )	6.7	8.75	3.42
Cost of debt ( $K_d$ )	0.065120419	0.061344821	0.063
WACOC	0.066337	0.049464	0.039328
ROIC (NOPAT/ CAP EMPLOYED)	0.12	0.13	0.17
EVA (ROIC- WACOC)	0.0537	0.0805	0.1357

## Economic Value Added (in ₹)

(EVA - As a measure of value creation through Management of Capital)

This scenario is used by the following consequence:- NOPAT including net operating profit less tax subtracting capital charge comprising of cost of capital multiplied by capital employed gives the title at a substantial exposure.

NOPAT - (WACC x Invested Capital)

Banks/Year	NOPAT			Capital Charge			EVA		
	2007-08	2006-07	2005-06	2007-08	2006-07	2005-06	2007-08	2006-07	2005-06
SBI	12,574	9,435	9,841	6,684	3,512	2,001	5,890	5,923	7,840
HDFC	2,988	2,134	1,644	1,129	503	295	1,859	1,631	1,349

After the detailed analysis of financial data and information of SBI & HDFC bank following findings have been derived.

- It was seen during the analysis that in Public Sector SBI ruled the market in terms of creating shareholders value in terms of amount where in the Private Sector HDFC was at the top spot in terms of percentage.
- After bearing all the expenditures including firms' return to all stakeholders, the remaining wealth i.e. EVA is accumulated by the shareholders after being reinvested so as to create an increment in its wealth resources.
- All SBI and HDFC Bank have been creating an EVA and value addition for its shareholders throughout 3 years.
- All banks are creating shareholders' value in terms of capital gain as well as reinvestment of the remaining profit into the business which will surely influence the stock prices in future.
- It was found that the reinvestment criteria and its impact will be a great deal for the firm's expected success and value creations for the firm in the near future.

Banking industry in India is undergoing a rapid metamorphosis. Their role of a traditional banker has been replaced with financial services provider for the clients. Most of the PSU and private sector banks in our country have already started looking at their portfolio of services offered and what they should do in the future for remaining competitive in the industry. As public sector banks are likely to undergo major consolidation, suddenly for many Indian banks things have changed. The following factors of interpretation serve the purpose of analyzing the overall concern of proving the study. The public sector banks lead the private banks when NOPAT is emphasized in terms of the analysis where SBI was in the front spot for each year respectively as it is the leading bank of India. The capital charge factor determines the impact that SBI Banks have a greater focus than HDFC banks in each year respectively. As being a public bank, they have to increase their image in market by giving higher return to their shareholders. As seen that ROIC is higher in all the three year's in HDFC bank than SBI bank. It has *greater* impact. The EVA in *percentage* terms was higher for private banks because the amount of invested capital is low compared to public sector banks. The EVA in rupees terms was higher for public sector banks compared to private sector banks in each of the years due to their invested capital gives higher return to public' sector banks so as to generate a consistent amount of NOPAT.

**(2) Hindustan Lever Limited, renamed Hindustan Unilever Limited****What is EVA?**

Traditional approaches for measuring shareholders' value creation have used parameters such as earnings capitalisation, market capitalisation and present value of estimated future cash flows. Extensive equity research has now established that it is not earnings per se, but value which is important. A new measure called 'Economic Value Added' (EVA) is increasingly being applied to understand and evaluate financial performance.

$EVA = \text{Net operating profit after taxes (NOPAT)} - \text{Cost of capital employed (COCE)}$

NOPAT = Profits after depreciation and taxes but before interest costs. NOPAT, thus, represents the total pool of profits available on an ungeared basis to provide a return to lenders and shareholders; and

$COCE = \text{Weighted average cost of capital (WACC)} \times \text{Average capital employed.}$

Cost of debt is taken as the effective rate of interest applicable to an 'AAA' rated company like HLL with an appropriate mix of short, medium and long-term debt, net of taxes. We have considered pre-tax rate of 14% after taking into account the trends over the years. Cost of equity is the return expected by the investors to compensate them for the variability in returns caused by fluctuating earnings and share prices.

Cost of Equity = Risk-free return equivalent to yield on long-term Government bonds (taken at 12.5%)  
(+)

Market-risk premium (taken at 9%) x Beta variant for the company (taken at 0.8), where the beta is a relative measure of risk associated with the company's shares as against the market as a whole.

Thus, HLL's cost of equity = 12.50% + 9.00% x 0.80 = 19.70%.

**What does EVA show?**

EVA is the residual income after charging the company for the cost of capital provided by lenders and shareholders. It represents the value added to the shareholders by generating operating profits in excess of the cost of capital employed in the business.

**When will EVA increase?**

EVA will increase if:

- (1) operating profits can be made to grow without employing more capital, i.e. greater efficiency;
- (2) additional capital is invested in projects that return more than the cost of obtaining new capital, i.e. profitable growth; and
- (3) capital is curtailed in activities that do not cover the cost of capital, i.e. liquidate unproductive capital.

**EVA in practice at Hindustan Lever Ltd.**

Hindustan Lever, the goal of sustainable long-term value creation for the shareholders is well understood by all the business groups. Following table shows the EVA trend of the company from 1997 to 2005 —

(₹ in crore)	1997	1998	1999	2000	2001	2002	2003	2004	2005
Cost of Capital Employed									
Average Debt	160	165	162	93	50	45	881	1,588	360
Average Equity	1,127	1,487	1,908	2,296	2,766	3,351	2,899	2,116	2,200



Average Capital Employed	1,287	1,652	2,070	2,389	2,816	3,396	3,780	3,704	2,560
Cost of Debt, post-tax %	8.82	9.10	8.61	8.46	7.72	6.45	4.88	5.19	3.38
Cost of Equity %	19.70	19.70	19.70	19.70	16.70	14.40	12.95	14.77	15.50
WACC	18.34	18.64	18.83	19.27	16.54	14.30	11.07	10.66	13.80
COCE	236	308	390	460	466	486	418	395	353
EVA									
PAT before exceptional items	580	837	1,070	1,310	1,541	1,716	1,804	1,199	1,355
Add: Interest after taxes	21	19	14	8	5	6	43	82	12
NOPAT	601	856	1,084	1,318	1,546	1,722	1,847	1,282	1,367
Less: COCE	236	308	390	460	466	486	418	395	353
EVA	365	548	694	858	1,080	1,236	1,429	887	1,014

(Data are taken from Annual Report of HLL)

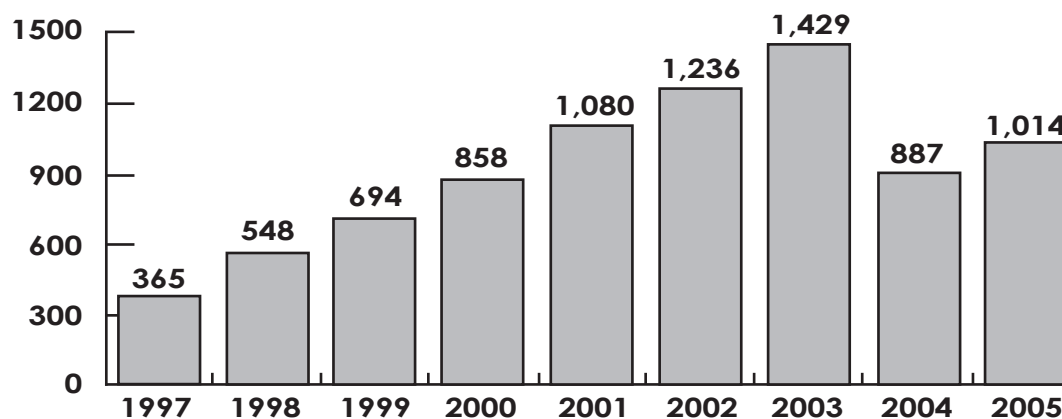

## 2.6 TRANSFER PRICING

Large businesses today are usually organized into different divisions for effective management control. In case of large multi-product companies each of the divisions may be a large manufacturing unit in their own right. When a company is organized into more than one division and if one division supplies its finished output as an input to another division, there raises the question of transfer pricing. **Transfer pricing is the price at which the supplying division prices its transfer of output to the user division.** It is different from the normal price in that both divisions are a part of same organization and therefore it is only an internal transfer and not a sale.

Transfer pricing refers to the pricing of flows of physical goods and services among the divisions of the same company. As the pricing of these flows is likely to have an impact **on** the performance evaluation of the divisions, the setting of transfer pricing policies within the company has great significance. It is possible that any given policy may favour some division and disfavour others.

The issue of transfer pricing acquires added significance when accounting is to be used for the purpose of divisional performance measurement. The major significance of transfer pricing is that it will be used to measure notional sales of one division, which uses the transferred output as its input. Thus transfer price used in the organization will **have** significant effect on the financial performance of, different divisions. This brings forth the need for establishing a transfer price free from all biases. It has to be equitable as possible as to the different divisions in the organization.

The determination of an appropriate transfer price is one of the major problems of responsibility centres. The implication of the transfer price is that for the selling division (the division goods/services are being transferred) it is a source of revenue, whereas, for the buying division (the division which is receiving/acquiring the goods/services) it is **an** element of cost. It will, therefore, have significant bearing on the revenues, costs, **and** profits of responsibility centres.

### 2.6.1 Any Transfer Pricing System Should Aim To

- Ensure that resources are allocated in an optimal manner
- Promote goal congruence
- Motivate divisional managers
- Facilitate the assessment of management performance
- Retain divisional autonomy.

There are varieties of transfer pricing methods but in order to assess the validity **and** acceptability of different transfer pricing methods, the criteria generally used are -

**In the first place** the transfer price should be objectively determinable.

**Secondly**, it should be equal to the value of the intermediate products being transferred that is the transfer price should compensate the transferring division and charge the buying/acquiring division in keeping with the value of the functions performed and/or the value of the product exchanged.

**Finally**, it should be compatible with the policy that maximizes attainment of company goals and evaluation of segment performance.

Although different approaches will result in different figures the limits within which the transfer price should fall can be summarized as follows:

#### **Minimum:**

The sum of the selling division's marginal cost and the opportunity cost of the resources used.

**Maximum:**

The lowest market price at which the buying division could acquire the goods or services externally, less any internal cost savings in packaging and delivery.

The difference between the two limits represents the savings made by producing internally as opposed to buying in from outside.

**2.6.2 Transfer Pricing System**

Introduction and operation of an effective system of transfer pricing in an organization is entangled with at least three major aspect of corporate policy of the organization. They are:

- (1) Divisional autonomy,
- (2) Transfer pricing, and
- (3) Performance evaluation.

**The first two aspects** are specific ingredients of general area of corporate control. In most of the large divisionalised organizations the divisional manager's freedom of action is not absolute. Divisional managers are to make periodic reports to the corporate office. The corporate policy on this may include: -

- The level of details in these reports,
- The accountability of decisions and actions,
- The frequency of overruling of the divisional managers decisions, and so on.

The corporate office closely controls those aspects, which affect the operations of other divisions. This includes quantities of output transferred among the divisions and also the prices at which the transfers take place (the transfer price).

**2.6.3 Transfer price policies:**

Transfer price policies refer to the selection of policies/methods that govern the calculations of such prices under various circumstances. The concern of transfer price policies with developing a transfer pricing system that allows:

- I. A measure of performance to reflect the use of resources by a division, and
- II. The optimal allocation of the organization resources.

**2.6.4 Methods of Transfer Prices**

Transfer pricing methods are broadly classified into the three categories –

- Cost-based prices
- Market-based prices, and
- Negotiated prices.

**(1) Cost-Based Methods**

**Cost price:** According to this transfer price is equal to the cost price. This means the goods or services transferred will be priced on the basis of the selling division's unit cost of production. The cost could be either actual cost of production or, where available, standard cost of production.

The merit of this method is simplicity and convenience because all the required information is available in the cost accounting records. But it is inappropriate for profit centre analysis. The reason is that the prices based on cost would distort the profit figures. For the selling division, the profit figures

would underestimate, as it will not earn any profit on goods/services sold to the sister divisions. The profit for the purchasing department would be inflated to the extent the cost of purchases of goods would be: because there is no element of profit for the selling divisions. If profit figures were distorted, the profit analysis would not be of much value.

**Standard Cost:**

Under this method, all the transfers are valued at standard cost. The variances from the standard cost are normally absorbed by the **supplying division**. In certain cases variances from the standard cost are transferred to the user **division and** therefore inventories are carried both by the supplying and receiving division at **standard cost**. Once the standards are properly set, operation of this system is simple. However the responsibility of the profit performance is centralized. Profit performance of each **division** cannot be measured,

**Cost Plus a Normal Mark-up :**

This type of transfer price is an improvement over the first category. It includes, besides unit cost of production, some profit margin or normal mark-up. Thus, the price received/ paid by the selling and the purchasing departments respectively will contain an element of profit. There are two ways in which the normal mark-up/profit margin is determined. First, the management of the organization set a target profit. Alternatively, the normal mark-up may be equivalent to the profit margin that a competing organization might reasonably be expected to realize. If the second basis is adopted, the transfer pricing approximate a market value. Depending upon its closeness to the real market value, it may be useful for the profit centre analysis. But if the basis is the managerial predetermined target, the mark-up is an artificial margin dictated by policy. Therefore, its validity as performance measurement of a division/ divisional manager is open to question. On the whole, therefore, this type of transfer price has no unique value of its own for profit 'centre analysis.

**Incremental cost:**

Another basis of transfer prices is the incremental cost of the selling division. Depending upon the circumstances, incremental cost can be computed in two ways. The first situation may be such that the entire production of the selling division is transferred to the sister divisions, and there are no independent outside customers for the goods. In that case, incremental cost includes all variable plus any fixed costs directly and exclusively attributable to the internal transfer/internal divisional transfer. Transfer pricing at incremental cost defined in this sense is inconsistent with the objectives of measurement divisional profit as performance measurement.

An alternative market situation arises when there may be outside customers for the goods and the division is unable to produce the full demand (from the outside customers as well as sister divisions). The incremental cost to selling division in that case would be the revenue lost on sales to outside customers be foregone to make the internal transfer to a sister division. Then, the incremental cost would be market price for those goods/services. This version of the incremental cost data could be useful for profit centre analysis. The incremental cost data related to the internal production costs is not of much value.

**Two-part tariff:**

Under this variant, the selling division transfers at marginal cost (including any opportunity cost), but raises a fixed annual fee on the buying division for the privilege of receiving transfers at that price. The theory underlying this approach is that profit maximization will be facilitated in the buying division if it uses the appropriate marginal cost in its calculations of optimal output levels. The fixed fee is designed to cover a share of the selling division's fixed costs and provide a return on the capital employed in it, and thus both selling and buying divisions should be able to record a profit on intra-company transfers.

## (2) Market Price-based Methods

Another approach to transfer pricing is the market price based approach. There are three ways to arrive at the market price.

**First**, through the prevailing market price if there is an active market for the goods/services transferred between divisions. The prevailing price would require adjustment for discounts as well as for certain selling cost that are not involved in inter-divisional exchange. The merits of this basis of transfer price are:

- (i) Market prices represent the alternatives to the divisions. That is to say, if the selling division sells the outside customers, or if the buying division purchases the goods from outside suppliers, the market price will be the basis.
- (ii) They are neither arbitrary nor artificial; rather they reflect the collective values of buyers and sellers. In operational terms, a market price-based approach implies that the selling division will receive equal to what it would get by selling the goods to outside customers, while the purchasing division will pay what it would pay to outside suppliers. Yet, both the selling and the buying divisions would derive some special benefits. The advantages to the selling division include:
  - (a) No risk of bad debt, and
  - (b) No direct promotional expenses on sale to a sister division.

The special benefit of the buying department will be in the form of assured delivery schedules and full customer service. Therefore where divisions have the alternative to buy/sell to/from the open market, they would prefer to buy and sell to the sister division.

**Secondly** in cases where easily identified market prices are not available, costs plus a normal profit will be a reasonable approximation of the market price.

**Finally** in a situation in which market price is not readily available, bids from several different manufacturers form the basis. The low bid may be taken as the market price and used for internal transfer pricing. This alternative of market price suffers from two limitations: either spurious bid would be submitted by the bidders, or bids will not be submitted. This is likely because the bidders would come to know that the firm will not buy the goods but will only use the bid for internal pricing.

### **Market price less saving:**

Under this method the goods/services transferred between divisions are priced on the bases of prevailing market price less saving in form of discounts, certain selling expenses and direct promotional expenses that are not involved in inter-divisional transfer of goods and services.

## (3) Negotiated prices

The inter-divisional transfer pricing can also be based on a price mutually agreed upon by the buying as well as the selling divisions through negotiation. The advantage of this approach is that it will lead to a transfer price mutually advantageous to both, the divisions as well as the organization as a whole. The limitation is that it can be applied only in situations in which the selling division has a choice of customers and the purchasing division has a choice of suppliers.

## (4) Dual (two way) prices

Under this method of transfer pricing for segment performance evaluation, the transferring division is credited with one price but the acquiring division is charged at different price. The merit of this method is that it eliminates the possibility of conflict caused by a single transfer price in which case one segment receives relatively less contribution of profit because the price setting process entitles the segment to receive relatively more.



The price to be charged to the acquiring division should be based on what it costs the firm as a whole to produce and distribute the intermediate product internally under normal conditions, the appropriate incremental costs in nonrecurring situations, and full standard costs for long-run continuous situations. These prices reflect the effective cost of the resources consumed by the firm and by the segment.

For this reason, this is an appropriate basis for evaluating the performance of the user of those resources. The transferring division, on the other hand, should receive the market price for the intermediate products and if no market price exists, a negotiated price based on the market price of the final product should be used approximate the net realizable value of intermediate product. This price represents the best possible assessment of the exchange value of the intermediate product.

### 2.6.5 Transfer Pricing Practices

There is a large amount of documented sources on the transfer pricing policies used by companies all over the world. These studies have documented various aspects of transfer pricing policies such as –

- (a) Its role as an overall component of reporting and control system in companies
- (b) The effect of transfer pricing on intra corporate conflicts, and
- (c) Variations in transfer pricing policies across the world.

A brief summary of transfer pricing practices is as follows:

- i. Companies tend to look at transfer pricing not just as a mere accounting exercise, but as a tool in policy formulation towards achievement of corporate objectives.
- ii. Transfer pricing acts as a major source of political conflict within the organization and this takes place in respect of the method used for this purpose; different methods may, however, increase or decrease the possibility of conflict.
- iii. Companies, tend to use a variety of transfer pricing methods. However, the dominant among them are the market prices or the methods based modification of market prices.
- iv. International companies use conscious manipulation of transfer pricing as an instrument of maximizing achievement of corporate goals. An explicit example is the transfer of profit from subsidiaries to the parent companies or other companies in the group through the transfer pricing policies relating to supply of capital equipment or input by multinational companies.

### 2.6.6 Criteria

In assessing a system of transfer pricing, three criteria have to be, considered:

- 1) **Neutrality:** A system should not distort the way in which the business behaves; a control system that reduces the efficiency of the process is clearly unsatisfactory.
- 2) **Equity:** A system should not prevent the divisions from reporting meaningful profit figures; the whole idea of divisional organization is debased if the system prevents this from happening.
- 3) **Administrative convenience:** A system should not be so clumsy and expensive to operate that it starts to cost more than the benefits it provides.

#### Illustration 4

ABC Ltd has two divisions A and B. A division is currently operating at full capacity. It has been asked to supply its product to division B. Division A sells its product to its regular customers for ₹30 each. Division B (currently operating at 50 per cent capacity) is willing to pay ₹ 20 each for the component produced by division A (this represents the full absorption cost per component at division A). The components will be used by division B in supplementing its main product to



conform to the need of special order. As per the contract terms of sale, the buyer calls for reimbursement of full cost to division B, plus 10 per cent.

Division A has a variable cost of ₹ 17 per component. The cost per unit of division B subsequent to the buying part from division A is estimated as follows:

Particulars	₹
Purchased parts - outside vendors	90.00
Purchased part - division A	20.00
Other variable costs	50.00
Fixed overheads and administration	40.00
	200.00

The company uses return on investment in the measurement of divisional and division manager's performance.

*Required:*

- As manager of division A would you recommend sales of your output to division B at the stipulated price of ₹ 20?
- Would it be in the overall interest of the company for division A to sell its output to division B?
- Suggest an alternative transfer price and show how could it lead to goal congruence?

**Solution:**

- As manager of division A, I would not recommend sales at ₹ 20 per unit to division B. The division is already operating at its full capacity and the market is presumably absorbing all its output at ₹ 30 per unit. The internal transfer made to division B, hence, would reduce its profit (by ₹ 10 per unit) as well as the ROI.
- Decision Analysis (whether to transfer part from division A to division B at ₹ 20 per unit or not).

Particulars	Sold externally	Transferred to division
Sale price (Division A)	30.00	
Sale price (Division B) (₹ 200 + 10%)		220.00
<b>Less relevant/incremental cost:</b> For part of Division A	17.00	17.00
Purchased parts from outside		90.00
Other variable costs		50.00
Profit per unit	13.00	63.00

Yes it will be in the overall interest of the company that transfer takes place, as it would augment the company's profit by ₹ 50 per unit.

- (C) Dual price basis of effecting transfer is the most appropriate. In this case, the relevant transfer price will be ₹ 30.00 (sale) so far as division A is concerned, and ₹ 20 (purchase) so far as division B is concerned. It will keep the profits of division unaffected and will facilitate the utilization of the idle capacity of division B, as also increase its profit:

Particulars	₹
Sale price (₹ 210 + 10 per cent)	231.00
Less: costs (₹ 90 + ₹ 30 + ₹ 50)	170.00
	61.00

**Illustration 5**

The Best Industries Ltd has two divisions, A and B. Division A manufactures product X which it sells in outside market as well as to division B which processes it to manufacture Z. The manager of division B has expressed the opinion that the transfer price is too high.

The two divisional managers are about to enter into discussions to resolve the conflict, and the manager of division to supply him with some information prior to the discussions.

Division A has been selling 40000 units to outsiders and 10000 units to division B, all at ₹ 20 per unit. It is not anticipated that these demand will change. The variable cost is ₹ 12 per unit and the fixed costs are ₹ 2 lakh.

The manager of division A anticipates that division B will want a transfer price of ₹ 18. If he does not sell to division B ₹ 30000 of fixed costs and ₹ 175000 of assets can be avoided. The manager of division A would have no control over the proceeds from the sale of the assets and is judged primarily on his rate of return.

- Should the manager of division A transfer its products at ₹ 18 to division B?
- What is the lowest price that the division A should accept? Support your decision.

**Solution:**

- Comparative statement of Profit of Division A

Particulars	Alternative situations		
	Sell at ₹ 20	Transfer at ₹ 18	Do not transfer
<b>Sales revenue:</b>			
Market sales (40,000 units x ₹ 20)	8,00,000	8,00,000	8,00,000
Transfer to division B (10,000 units)	2,00,000	1,80,000	-
<b>Total (a)</b>	10,00,000	9,80,000	8,00,000
Variable cost ₹ 12 per unit	6,00,000	6,00,000	4,80,000
Fixed cost	2,00,000	2,00,000	1,70,000
<b>Total (b)</b>	8,00,000	8,00,000	6,50,000
<b>Total profit (a-b)</b>	2,00,000	1,80,000	1,50,000
<b>Total assets</b>	8,00,000	8,00,000	6,25,000
<b>ROI (percentage)</b>	25 %	22.50%	24 %

The manager of division A should not agree to sell at ₹ 18 per unit as it lowers down its rate of return.

- The lowest transfer price acceptable to division A is one, which maintains its rate of return of 24% (the ROI without selling to division B):

$$= (\text{Total sales revenue} - \text{Total cost}) / \text{Total assets}$$

$$= (8,00,000 + 10,000 \text{ TP} - 8,00,000) / 8,00,000 = 0.24$$

Where TP is transfer price per unit

10,000 TP = 1,92,000

TP = ₹ 19.20

The lowest transfer price acceptable to division A is ₹ 19.20 per unit.

### Illustration 6

A company AB Ltd. has two divisions, Division X manufactures a special type of electrical component and Division Y sells a finished product for which it requires one component per unit from X division. Division X sells the component in the external market @ ₹ 180 per unit and division X is also working at almost full capacity. The variable cost of manufacturing per component is ₹ 102.

Division Y is now operating at 50 % capacity. It has received a special order for its product. As Y is keen to get this order. Division Y will meet the special order at a price of ₹ 1200 per unit and it offers a price of ₹ 120 per component to division X. The cost per unit of Division Y is as:

Particulars	₹
Other purchased component	500
Component supplied by Division X	120
Other variable overheads	320
Fixed overheads	180
Total cost per unit	1120

- (i) As a manager of division X what decisions would you like to take on B's request for the supplies @ ₹ 120?
- (ii) Would it be any short-term economic advantage for AB Ltd. to make Division X transfer to Division Y at the price of ₹ 120?
- (iii) What would be the behavioural difficulties of the managers?

### Solution:

- (i) Since Division X is operating to near full capacity and has an external market at a price of ₹ 180 per unit as a manager of the division it would not be in the interest of the divisional profitability to supply at a price of ₹ 120. The offer is refused.
- (ii) Since Division Y is working below the capacity it would be in its interest to get the special order. The fixed cost of ₹ 180 included in the cost is not pertinent. This is a sunk cost. Thus if Division Y were to buy the component even at the market price of ₹ 180 its overall variable cost would be  $500+180+320 = 1000$  and a contribution of ₹ 200 per unit can be earned from the special order. Therefore Division Y should buy the component at the price of ₹ 180 per component and accept its special order and when the price paid for the component is ₹ 180, Division Y will be indifferent as to the buyer.
- (iii) Since the interest of AB Ltd. is best served by accepting the special order, Division Y should accept the special order, but the request of Division Y for the special price of the component should be turned down. If forced to sell then Division X will appear to lose for no fault of it, and Division Y profit appear to be more than normal for no special effort on its part.

### Illustration 7

A company has two divisions one producing an intermediate for which there is external market and another using this intermediate in finished product and it sells in the market. Each unit of finished product uses one unit of intermediate. The sales quantity is sensitive to the price charged and the selling division has developed the following sales schedule:

Selling price per unit (₹)	500	450	400	350	300	250
Sales units (No)	1,000	2,000	3,000	4,000	5,000	6,000

**Cost details are as:**

Particulars	Production Division	Selling Division
Variable Cost Per unit (₹)	55	35
Fixed Cost Per annum (₹)	3,00,000	4,50,000

The transfer price is ₹ 175 based on the a full cost basis.

- Prepare a statement of profit for each division and the company as a whole.
- Determine the selling price that will maximize the selling division profit and the price that will maximize the company's profit.
- Determine the which transfer price policy will maximize the overall company's profit.

**Solution:**

**(i) Profit statements**

₹ Thousand

Selling division					Production division		
Sales (units)	Revenue	Variable cost	Transfer price	Profit	Revenue	Variable cost	Profit
1000	500	35	175	290	175	55	120
2000	900	70	350	480	350	110	240
3000	1200	105	525	570	525	165	360
4000	1400	140	700	560	700	220	480
5000	1500	175	875	450	875	275	600
6000	1500	210	1050	240	1050	330	720

**Overall company's profitability = selling division profit + production division profit**

Sales units (No.)	1,000	2,000	3,000	4,000	5,000	6,000
Profit in (₹ '000)	410	720	930	1,040	1,050	960

- It may be seen that the selling division has the maximum profit at a volume of sales at 3000 @ ₹ 400 per unit and whereas overall company's profit is maximum at 5000 units @ ₹ 300 per unit.
- When there is no market for the intermediate and there is no capacity constraint the correct transfer price is the marginal cost of the supplying division for that output at which the marginal cost equals the receiving department's net marginal revenue from converting the intermediate. When unit variable cost is constant and fixed cost do not change the marginal cost will be the same as the variable cost of supplying division viz. ₹ 55 per unit. The selling division will have the following marginal cost and revenue schedule at the transfer price of ₹ 55 per unit.



in ₹ thousand

Output units)	Marginal cost	Marginal Revenue
1,000	90	500
2,000	90	400
3,000	90	300
4,000	90	200
5,000	90	100
6,000	90	Nil

**Marginal cost** = transfer price + own variable cost =  $55+35 = ₹ 90$

Thus it is seen that at an output of 5000 units (approximate) (price ₹ 300 per unit) the marginal cost equals the marginal revenue and this is the price - volume that will maximize the overall company's profitability.

#### Illustration 8

Division A is a profit centre that produces three products X, Y and Z and each product has an external market.

**The relevant data is as:**

Particulars	X	Y	Z
External market price per unit (₹)	48	46	40
Variable cost of production (Division A) (₹)	33	24	28
Labour hours per unit (Division A)	3	4	2
Maximum external sales units	800	500	300

Up to 300 units of Y can be transferred to an internal Division B.

Division B has also the option of purchasing externally at a price of ₹ 45 per unit. Determine the transfer price for Y. The total labour hours available in division A is:

- (a) 3800 hours
- (b) 5600 hours

**Solution:**

Labour hours requirement to meet potential external demand =  $800 \times 3 + 500 \times 4 + 300 \times 2 = 5000$  hours

**Contribution per unit**

Sl No.	Particulars	X	Y	Z
a.	Selling price per unit (₹)	48	46	40
b.	Variable cost per unit (₹)	33	24	28
c.	Contribution per unit (a - b)	15	22	12
d.	Labour hours per unit	3	4	2
e.	Contribution per labour hour (₹) (c / d)	5	5.50	6
	Ranking	III	II	I

**(a)** When labour hour is limited to 3800 hours

- First            300 units of Z @ 2 hours = 600 hours  
 Second        500 units of Y @ 4 hours = 2000 hours  
 \* Third        400 units of X @ 3 hours = 1200 hours

\* This is determined from the balance hours

If 300 units of Y has to be transferred to division B then an additional 300 units of Y will have to be produced using  $300 \times 4 = 1200$  hours. Thus no production X will be possible. Transfer price = variable cost of Y = ₹ 24

Since Division A is working at full capacity then there will be an opportunity loss from not being able to meet all the demand.

Opportunity loss = contribution foregone by not producing X = 4 hours  $\times$  ₹ 5 per hour = ₹ 20.

Since the transfer price should be = ₹ 24 + ₹ 20 = ₹ 44.

**(b)** When labour hour is limited to 5600 hours

The maximum time required to all external demand

= 3800 hours as calculated above +  $400 \times 3$  (for the extra A)

5000 hours, leaving a balance of 600 hours to meet internal demand of Y.

With the surplus 600 hours  $600/4 = 150$  units of Y can be produced within available capacity. The transfer price for this will be just the variable cost @ ₹ 24 per unit. Thus total cost for 150 units is ₹ 3600.

To produce balance of 150 units of Y for internal consumption 600 labour hours will have to be released by curtailing of production of X. And contribution forgone on X =  $600 \times 5 = ₹ 3000$ .

Thus the total price for 300 units of Y internal demand

= variable cost of 300 units of Y + Opportunity loss of ₹ 3000 = 10,200

Transfer price per unit =  $10200/300 = ₹ 34$ .



### Illustration 9

Rana manufactures a product by a series of mixing of ingredients. The product is packed in company's made bottles and put into an attractive carton. One division of company manufactures the bottles while another division prepares the mix that does the packing.

The user division obtained the bottle from the bottle manufacturing division. The bottle manufacturing division has obtained the following quotations from an external source for supply of empty bottles.

No. of bottles	For 8,00,000 bottles	For 12,00,000 bottles
Total price offer (₹)	14,00,000	20,00,000

The estimated cost is:

No. of bottles	For 8,00,000 bottles	For 12,00,000 bottles
Total cost (₹)	10,40,000	14,40,000

The sales value and the end cost in the mixing / packing division are:

No. of bottles	For 8,00,000 bottles	For 12,00,000 bottles
Total Sales value (₹)	91,20,000	1,27,80,000
Total cost** (₹)	64,80,000	96,80,000

\*\* Excluding cost of bottles

There is a considerable discussion as to the proper transfer price from the bottle division to the marketing division.

The divisional manager's salary is an incentive bonus based on profits of the centres.

You are required to show for the given two levels of activity the profitability of the two divisions and the total organization based on appropriate transfer price determined on the basis of:

- Shared profit related to the cost
- Market price

#### Solution:

#### i. Profitability of the division related to the cost

Figures in thousand

	Activity level	
No of units	800	1200
Sales value of finished product (₹)	9120	12780
Less cost: (₹)		
(i) Product mixing / packing (₹)	6480	9680
(ii) Bottle manufacturing (₹)	1040	1440
Total cost (₹) (i)+(ii)	7520	11120
Profit (₹)	1600	1660
Divisional proportion of total profit (basis of relative cost) :		
Bottle manufacturing	13.83%	12.95%
Product mixing / packing	86.17%	87.05%



Profit apportionment :		
Bottle manufacturing (₹)	221.28	214.97
Product mixing/ packing (₹)	1378.7	1445.03
Transfer price for bottles (₹):		
Cost (₹)	1040	1440
Profit apportioned (₹)	221.28	214.97
Unit price of bottle (₹)	1.575	1.379

The profitability of the company as a whole = sum of the profit of the divisions

## ii. Profitability of the division based on market price

Figures in thousand

	Activity level	
No of units	800	1200
<i>Bottle manufacturing division</i>		
Market price (₹)	1400	2000
Less: cost (₹)	1040	1440
<b>Profit (A)</b>	<b>360</b>	<b>560</b>
<i>Product mix division</i>		
Market price (₹)	9120	12780
Less: bottle cost (₹) @ market price	1400	2000
Own manufacturing	6480	9680
<b>Profit (B)</b>	<b>1240</b>	<b>1100</b>
<b>Total Profit (A+ B)</b>	<b>1600</b>	<b>1660</b>

### Comparative profit summary

Figures in thousand

Division	Basis on Relative Cost (₹ )		Basis on Market Price	
No. of units	800	1200	800	1200
Bottle Manufacturing (₹)	221	215	360	560
Product Mixing (₹)	1,379	1,445	1,240	1,100

### Illustration 10

Fastener Limited is having production shops reckoned as Cost Centres. Each shop charges other shop for material supplied and services rendered.

The shops are motivated through goal congruence, autonomy and management efforts. Fastner Limited is having a welding shop and painting shop. The welding shop welds annually 75,000 purchased items with other 1,50,000 shop made parts into 12,000 assemblies. The assemblies are having total cost of ₹ 9.50 each and are sold in market at ₹ 12 per assembly. Out of the total production, 80% is diverted to painting shop at same price ruling in the market. Welding shop incurs a fixed cost of ₹ 25,000 per annum. The painting shop is having fixed cost of 30,000 and its cost of painting including transfer price from welding shop comes to ₹ 20 per unit. This shop sales all units transferred to it by welding shop at ₹ 25 per assembly.



**Your are required to:**

(a) Find out profit of individual cost centre and overall profitability of the concern.

**Solution:**

**Present Profitability:**

Particulars	Welding			Paints		
	Unit	Rate	Value (₹)	Unit	Rate	Value (₹)
Sales in Market	2,400	12	28,800	9,600	25	2,40,000
Transfer to paint	9,600	12	1,15,200	---	---	—
	<b>12,000</b>	<b>-</b>	<b>1,44,000</b>	<b>9,600</b>	<b>-</b>	<b>2,40,000</b>
Less: Variable Cost	12,000	9.50	1,14,000	9,600	20	1,92,000
Contribution			30,000			48,000
Less: Fixed Cost			25,000			30,000
<b>Profit</b>			<b>5,000</b>			<b>18,000</b>

Profit for the company as a whole will be ₹ 5000 + ₹ 18,000 = ₹ 23,000.

(b) Recommend courses of action if painting shop wishes to purchase its full requirement (at market price which is ₹ 10 per assembly) either from open market or from welding shop at market price of ₹ 10 per assembly.

Give reasons for your recommendations,

**Solution:**

**(i) Painting shop purchasing at ₹ 10**

Particulars	Welding			Paints		
	Unit	Rate	Value (₹)	Unit	Rate	Value (₹)
Sales in Market	2,400	12	28,800	9,600	25	2,40,000
Less: Variable Cost	2,400	9.50	22,800	9,600	18*	1,72,800
Contribution			6,000			67,200
Less: Fixed Cost			25,000			30,000
<b>Profit/( Loss)</b>			<b>(19,000)</b>			<b>37,200</b>

Overall profitability for the company as a whole ₹ (19,000) + 37,200 = 18,200.

\* It is given in the question that cost of painting including transfer price from welding shop is ₹ 20 per unit. The transfer price from welding shop is ₹ 12 per unit. Therefore, the variable cost of ₹ 8 (₹ 20 – 12) is incurred by painting shop exclusively. The painting shop will be purchasing its requirement from open market at ₹ 10 per unit. Therefore, the variable cost per unit in painting shop will be ₹ 18 (₹ 10 + 8). This point should be noted carefully.

**(ii) Transfer at market price at ₹ 18**

Particulars	Welding			Paints		
	Unit	Rate	Value (₹)	Unit	Rate	Value (₹)
Sales in Market	2,400	12	28,800	9,600	25	2,40,000
Transfer Value	9,600	10	96,000	-	-	-
	12,000	-	1,24,800			2,40,000
Less: Variable Cost	12,000	9.50	1,14,000	9,600	18	1,72,800
Contribution			10,800			67,200
Less: Fixed Cost			25,000			30,000
<b>Profit/( Loss)</b>			<b>(14,200)</b>			<b>37,200</b>

Overall Profit of the Company ₹ 37,200 + (14,200) = 23,000

Paint shop should be refrained from buying from the open market since this will reduce the overall profitability of the company.

Transfer to paint shop at market price (₹18) should be the decision since by the paint is not affected and overall profitability of the company remains the same.

**Illustration 11**

A large Company is organized into several manufacturing divisions. The policy of the company is to allow the Divisional managers to choose their sources of supply and when buying from or selling to sister divisions, to negotiate the prices just as they will for outside purchase or sales.

Division X buys all of its requirements of its main raw material R from Division Y. The full manufacturing cost of R for Division Y is ₹ 88 per kg at normal volume.

Till recently, Division Y was willing to supply R to Division X at a transfer price of ₹ 80 per kg. The incremental cost of R for Division Y is ₹ 76 per kg. Since Division Y is now operating at its full capacity, it is unable to meet the outside customers' demand for R at its market price of ₹ 100 per kg. Division Y therefore threatened to cut off supplies to Division X unless the latter agree to pay the market price for R.

Division X is resisting the pressure because its budget based on the consumption of 1,00,000 per kg per month at a price of ₹ 80 per kg. is expected to yield a profit at ₹ 25,00,000 per month and so a price increase to ₹ 100 per kg. will bring the Division X close to breakeven point.

Division X has even found an outside source for a substitute material at a price of ₹ 95 per kg. Although the substitute material is slightly different from R, it would meet the needs of Division X. Alternatively; Division X is prepared to pay Division Y even the manufacturing cost of ₹ 88 per kg.

**Required**

- (i) Using each of the transfer price of ₹ 80, ₹ 88, ₹ 95 and ₹ 100 show with supporting calculations, the financial results as projected by the
  - (a) Manager of Division X
  - (b) Manager of Division Y
  - (c) Company
- (ii) Comment on the effect of each transfer price on the performance of the Managers of Division X and Division Y.
- (iii) If you were to make a decision in the matter without regard to the view of the individual Divisional Managers, where should Division X obtain its material from and at what price?



**Solution:**

**(i) Statement showing impact on Divisional profit with different transfer prices**

Division X (Transferee)		Division Y (Transferor)	
<b>(a) Transfer Price ₹ 80</b>			
			₹
		Sales (1,00,000 x 80 )	80,00,000
		Less: VC(1,00,000 x 76)	76,00,000
Profit Budgeted	25,00,000	Profit	4,00,000
<b>Company's Profitability = (25,00,000 + 4,00,000) = 29,00,000</b>			

Division X (Transferee)		Division Y (Transferor)	
<b>(b) Transfer Price ₹ 88</b>			
			₹
		Sales (1,00,000 x 88 )	88,00,000
		Less: VC (1,00,000 x 76)	76,00,000
Profit Budgeted	25,00,000	Profit	12,00,000
Less: Addl Cost (1,00,000 x 8)	8,00,000		
Net Profit	17,00,000		
<b>Company's Profitability = (17,00,000 + 12,00,000) = 29,00,000</b>			

Division X (Transferee)		Division Y (Transferor)	
<b>(c) Transfer Price ₹ 95</b>			
			₹
		Sales (1,00,000 x 95 )	95,00,000
		VC (1,00,000 x 76)	76,00,000
Profit Budgeted	25,00,000	Profit	19,00,000
Less: Addl Cost (1,00,000 x 15)	15,00,000		
Net Profit	10,00,000		
<b>Company's Profitability = (10,00,000 + 19,00,000) = 29,00,000</b>			

Division X (Transferee)		Division Y (Transferor)	
<b>(d) Transfer Price ₹ 100</b>			
			₹
		Sales (1,00,000 x 100)	1,00,00,000
		VC (1,00,000 x 76)	76,00,000
Profit Budgeted	25,00,000	Profit	24,00,000
Less: Addl Cost (1,00,000 x 20)	20,00,000		
Net Profit	5,00,000		
<b>Company's Profitability = (5,00,000 + 24,00,000) = 29,00,000</b>			

**(ii) Comment on the different transfer prices**

- Transfer price of ₹ 80 given a good incentive to Manager of Div. X whether no incentive to Manager of Div. Y even though he can sell outside and show better profits.
- Transfer prices of ₹ 88 reduce the profit of Division X and boosts the performance of Div.Y.
- Transfer prices of ₹ 95 further reduced the profits of Division X and improve the profit of Div. Y.
- Transfer price of ₹ 100 put Division X to stand on its own feet vis-à-vis market price and the performance of Div. Y improves.
- Regardless of the view of the individual managers, the position may be as under: X to buy substitute at ₹ 95 per kg. from market (additional cost ₹ 15 per unit), Y to sell entire quantity of R at the market price of ₹ 100 to outsiders.

X	₹	Y	₹
Budgeted Profit	25,00,000	Sales (1,00,000 x 100)	1,00,00,000
Addl. Cost (1,00,000 x 15)	15,00,000	VC (1,00,000 x 76)	76,00,000
Net Profit	10,00,000	Profit	24,00,000
<b>Company's Profitability = (10,00,000 + 24,00,000) = 34,00,000</b>			

**Illustration 12**

A Company is organized into two large divisions. Division A produces a component which is used by division B in making a final product. The final product is sold for ₹ 400 each. Division A has a capacity to produce 2,000 units and the entire quantity can be purchased by division B.

Division A informed that due to installation of new machines, its depreciation cost had gone up and hence wanted to increase the price of the component to be supplied to Division B to ₹ 220. Division B however, can buy the component from the outside market at ₹ 200 each. The variable costs of Division A are ₹ 190 and fixed costs ₹ 20 per component. The variable costs of Division B in manufacturing the final product by using the component are ₹ 150 (excluding the component cost).



Present statements indicating the position of each Division and the company as a whole taking each of the following situations separately:

- (i) If there are no alternative uses for the production facilities of A, will the company benefit if Division B buys from outside suppliers at ₹ 200 per component?
- (ii) If internal facilities of A are not otherwise idle and the alternative use of the facilities will give an annual cash operating saving of ₹ 30,000 to Division A, should Division B purchase the component from outside suppliers?
- (iii) If there are no alternative uses for the production facilities of Division A and the selling price for the component in the outside market drops by ₹ 15 should Division B purchase from outside suppliers?
- (iv) What transfer price would you fix for the component in each of the above three circumstances?

**Solution:**

(i)

Division A		Division B	
<b>If purchase from Outside suppliers</b>			
			₹
		Sales (2,000 x 400)	8,00,000
		VC - Purchase (2,000 x 200)	4,00,000
		- Mfg. (2,000 x 150)	3,00,000
		Profit	1,00,000
<b>Company's contribution as a Whole = 1,00,000</b>			

Division A		Division B	
<b>If purchase from Division A</b>			
			₹
Sales (2,000 x 220)	4,40,000	Sales (2,000 x 400)	8,00,000
VC (2,000 x 190)	3,80,000	VC – Div A (2,000 x 220)	4,40,000
		- Div B (2,000 x 150)	<u>3,00,000</u>
			7,40,000
Contribution	60,000	Contribution	60,000
<b>Company's contribution as a Whole = (60,000 + 60,000) = 1,20,000</b>			

(ii) **Alternative use of facilities by Division A and Div B purchased from Outside Markets**

Division A		Division B	
			₹
Contribution from use of facilities	30,000	Sales (2,000 x 400)	8,00,000
		VC - Purchase (2,000 x 200)	4,00,000
		- Div B (2,000 x 150)	<u>3,00,000</u>
			7,00,000
Contribution	30,000	Contribution	1,00,000
<b>Company's contribution as a Whole = (1,00,000 + 30,000) = 1,30,000</b>			

(iii)

Division A		Division B	
			₹
		Sales (2,000 x 400)	8,00,000
		VC - Purchase (2,000 x 185)	3,70,000
		- Div B (2,000 x 150)	<u>3,00,000</u>
			6,70,000
		Contribution	1,30,000
<b>Company's contribution as a Whole = 1,30,000</b>			

(iv) Computation of Transfer price

(a) If alternative use of facilities are not available for A:	
Charge Variable Cost	₹ 190
(b) If A's facilities can be used	
Variable Cost	₹ 190
Opportunity cost 30,000 / 2,000	₹ 15
Total Transfer Price	₹ 205

(c) If market price is reduced to ₹ 185 and alternative use of facilities are not available for A Charge variable Cost ₹ 190

## 2.7 INTERACTION OF TRANSFER PRICING AND TAXATION- POST EVALUATION OF STRATEGIC BUSINESS ARRANGEMENTS

There is no legal or universally accepted definition of business restructuring. In the context of this discussion, business restructuring is defined as the cross-border redeployment by a multinational enterprise (MNE) of functions, assets and/or risks. A business restructuring may involve cross-border transfers of valuable intangibles, although this is not always the case. It may also or alternatively involve the termination or substantial renegotiation of existing arrangements. Business restructurings that are within the scope of this discussion primarily consist of internal reallocation of functions, assets and risks within an MNE, although relationships with third parties (e.g. suppliers, sub-contractors, customers) may also be a reason for the restructuring and/or be affected by it.

Since the mid-90's, business restructurings have often involved the centralisation of intangible assets and of risks with the profit potential attached to them. They have typically consisted of:

- ❖ Conversion of full-fledged distributors into limited-risk distributors or commissionnaires for a foreign associated enterprise that may operate as a principal,
- ❖ Conversion of full-fledged manufacturers into contract-manufacturers or toll-manufacturers for a foreign associated enterprise that may operate as a principal,
- ❖ Transfers of intangible property rights to a central entity (e.g. a so-called "IP company") within the group.

There are also business restructurings whereby more intangibles and/or risks are allocated to operational entities (e.g. to manufacturers or distributors). Business restructurings can also consist of the rationalisation, specialisation or de-specialisation of operations (manufacturing sites and / or

processes, research and development activities, sales, services), including the downsizing or closing of operations. The arm's length principle and guidance here apply in the same way to all types of business restructuring transactions that fall within the definition irrespective of whether they lead to a more centralised or less centralised business model.

Business restructurings are typically accompanied by a reallocation of profits among the members of the MNE group, either immediately after the restructuring or over a few years. The implementation of integrated business models and the development of global organisations, where they are done for bona fide commercial reasons, highlight the difficulty of reasoning in the arm's length theoretical environment which treats members of an MNE group as if they were independent parties. There is certain conceptual difficulty with applying the arm's length principle in practice.

### **Part I : Special considerations for risks**

Risks are of critical importance in the context of business restructurings. An examination of the allocation of risks between associated enterprises is an essential part of the functional analysis. Usually, in the open market, the assumption of increased risk would also be compensated by an increase in the expected return, although the actual return may or may not increase depending on the degree to which the risks are actually realized. Business restructurings often result in local operations being converted into low risk operations (e.g. "low risk distributors", or "low risk contract manufacturers") and being allocated relatively low (but generally stable) returns on the grounds that the entrepreneurial risks are borne by another party to which the residual profit is allocated. It is therefore important for tax administrations to assess the reallocation of the significant risks of the business that is restructured and the consequences of that reallocation on the application of the arm's length principle to the restructuring itself and to the post-restructuring transactions.

#### **2.7.1 Contractual terms**

Contractual arrangements are the starting point for determining which party to a transaction bears the risk associated with it. Accordingly, it would be a good practice for associated enterprises to document in writing their decisions to allocate or transfer significant risks before the transactions with respect to which the risks will be borne or transferred occur, and to document the evaluation of the consequences on profit potential of significant risk reallocations. Where no written terms exist, the contractual relationships of the parties must be deduced from their conduct and the economic principles that generally govern relationships between independent enterprises.

A tax administration is entitled to challenge the purported contractual allocation of risk between associated enterprises if it is not consistent with the economic substance of the transaction. Therefore, in examining the risk allocation between associated enterprises and its transfer pricing consequences, it is important to review not only the contractual terms but also the following additional questions:

- ❖ Whether the conduct of the associated enterprises conforms to the contractual allocation of risks,
- ❖ Whether the allocation of risks in the controlled transaction is arm's length, and
- ❖ What the consequences of the risk allocation are.

#### **2.7.2 Whether the conduct of the associated enterprises conforms to the contractual allocation of risks**

In transactions between independent enterprises, the divergence of interests between the parties ensures that they will ordinarily seek to hold each other to the terms of the contract, and that contractual terms will be ignored or modified after the fact generally only if it is in the interests of both parties. The same divergence of interests may not exist in the case of associated enterprises, and it is therefore important to examine whether the conduct of the parties conforms to the terms of the contract or whether the parties' conduct indicates that the contractual terms have not been followed or are a sham. In such cases, further analysis is required to determine the true terms of the transaction.

The parties' conduct should generally be taken as the best evidence concerning the true allocation of risk.



**Example 1:**

Assume a business in which a manufacturer sells property to an associated distributor in another country and the distributor is claimed to assume all exchange rate risks, but the transfer price appears in fact to be adjusted so as to insulate the distributor from the effects of exchange rate movements. In such a case, the tax administrations may wish to challenge the purported allocation of exchange rate risk.

**Example 2:**

It is relevant to business restructurings is where a foreign associated enterprise assumes all the inventory risks by contract. When examining such a risk allocation, it may be relevant to examine for instance where the inventory write-downs are taken (*i.e.* whether the domestic taxpayer is in fact claiming the write-downs as deductions) and evidence may be sought to confirm that the parties' conduct supports the allocation of these risks as per the contract.

**Example 3:**

The determination of which party bears credit risk in a distribution arrangement. In full-fledged distribution agreements, the bad debt risk is generally borne by the distributor who books the sales revenue (notwithstanding any risk mitigation or risk transfer mechanism that may be put in place). This risk would generally be reflected in the balance sheet at year end. However, the extent of the risk borne by the distributor at arm's length may be different if the distributor receives indemnification from another party (*e.g.* from the supplier) for irrecoverable claims, and/or if its purchase price is determined on a resale price or commission basis that is proportionate to the cash (rather than invoiced) revenue. The examination of the actual conditions of the transactions between the parties, including the pricing of the transactions and the extent, if any, to which it is affected by credit risk, can provide evidence of whether in actual fact it is the supplier or the distributor (or both) who bear(s) the bad debt risk.

Determining whether the allocation of risks in the controlled transaction is arm's length. Relevant guidance on the examination of risks in the context of the functional analysis is an important parameter, which is based on the following factors:

**2.7.3 Role of comparables**

Where data evidence a similar allocation of risk in comparable uncontrolled transactions, then the contractual risk allocation between the associated enterprises is regarded as arm's length. In this respect, comparables data may be found either in a transaction between one party to the controlled transaction and an independent party ("internal comparable") or in a transaction between two independent enterprises, neither of which is a party to the controlled transaction ("external comparable"). Generally, the search for comparables to assess the consistency with the arm's length principle of a risk allocation will not be done in isolation from the general comparability analysis of the transactions with which the risk is associated.

The comparables data will be used to assess the consistency with the arm's length principle of the controlled transaction, including the allocation of significant risks in said transaction.

**2.7.4 Cases where comparables are not found**

Of greater difficulty and contentiousness is the situation where no comparable is found to evidence the consistency with the arm's length principle of the risk allocation in a controlled transaction. Just because an arrangement between associated enterprises is one not seen between independent parties should not of itself mean the arrangement is non-arm's length. However, where no comparables are found to support a contractual allocation of risk between associated enterprises, it becomes necessary to determine whether that allocation of risk is one that might be expected to have been agreed between independent parties in similar circumstances.

This determination is by nature subjective, and it is desirable to provide some guidance on how to make such a determination in order to limit to the extent possible the uncertainties and risks of double taxation it can create. One relevant, although not determinative factor that can assist in this

determination is the examination of which party(ies) has (have) relatively more control over the risk. In arm's length transactions, another factor that may influence an independent party's willingness to take on a risk is its financial capacity to assume that risk. Beyond the identification of these two relevant factors, it is not possible to provide prescriptive criteria that would provide certainty in all situations. The determination that the risk allocation in a controlled transaction is not one that would have been agreed between independent parties should therefore be made with great caution considering the facts and circumstances of each case.

### **2.7.5 Risk allocation and control**

Relevance of the notion of "control"

The question of the relationship between risk allocation and control as a factor relevant to economic substance is addressed at paragraph 1.49. The statement in that paragraph is based on experience. In the absence of comparables evidencing the consistency with the arm's length principle of the risk allocation in a controlled transaction, the examination of which party has greater control over the risk can be a relevant factor to assist in the determination of whether a similar risk allocation would have been agreed between independent parties in comparable circumstances. In such situations, if risks are allocated to the party to the controlled transaction that has relatively less control over them, the tax administration may decide to challenge the arm's length nature of such risk allocation.

### **2.7.6 Meaning of "control" in this context**

"Control" should be understood as the capacity to make decisions to take on the risk (decision to put the capital at risk) and decisions on whether and how to manage the risk, internally or using an external provider. This would require the company to have people – employees or directors – who have the authority to, and effectively do, perform these control functions. Thus, when one party bears a risk, the fact that it hires another party to administer and monitor the risk on a day-to-day basis is not sufficient to transfer the risk to that other party.

While it is not necessary to perform the day-to-day monitoring and administration functions in order to control a risk (as it is possible to outsource these functions), in order to control a risk one has to be able to assess the outcome of the day-to-day monitoring and administration functions by the service provider (the level of control needed and the type of performance assessment would depend on the nature of the risk). This can be illustrated as follows.

Assume that an investor hires a fund manager to invest funds on its account. Depending on the agreement between the investor and the fund manager, the latter may be given the authority to make all the investment decisions on behalf of the investor on a day-to-day basis, although the risk of loss in value of the investment would be borne by the investor. In such an example, the investor is controlling its risks through three relevant decisions: the decision to hire (or terminate the contract with) that particular fund manager, the decision of the extent of the authority it gives to the fund manager and objectives it assigns to the latter, and the decision of the amount of the investment that it asks this fund manager to manage. Moreover, the fund manager would generally be required to report back to the investor on a regular basis as the investor would want to assess the outcome of the fund manager's activities. In such a case, the fund manager is providing a service and managing his business risk from his own perspective (e.g. to protect his credibility). The fund manager's operational risk, including the possibility of losing a client, is distinct from his client's investment risk. This illustrates the fact that an investor who gives to another person the authority to make all the day-to-day investment decisions does not necessarily transfer the investment risk to the person making these day-to-day decisions.

As another example, assume that a principal hires a contract researcher to perform research on its behalf. Assume the arrangement between the parties is that the principal bears the risk of failure of the research and will be the owner of the outcome of the research in case of success, while the contract researcher is allocated a guaranteed remuneration irrespective of whether the research is a success or a failure, and no right to ownership on the outcome of the research.

Although the day-to-day research would be carried on by the scientific personnel of the contract researcher, the principal would be expected to make a number of relevant decisions in order to control its risk, such as: the decision to hire (or terminate the contract with) that particular contract researcher, the decision of the type of research that should be carried out and objectives assigned to it, and the decision of the budget allocated to the contract researcher. Moreover, the contract researcher would generally be required to report back to the principal on a regular basis, e.g. at predetermined milestones. The principal would be expected to be able to assess the outcome of the research activities. The contract researcher's own operational risk, e.g. the risk of losing a client or of suffering a penalty in case of negligence, is distinct from the failure risk borne by the principal.

As a third example, suppose now that a principal hires a contract manufacturer to manufacture products on its behalf, using technology that belongs to the principal. Assume that the arrangement between the parties is that the principal guarantees to the contract manufacturer that it will purchase 100% of the products that the latter will manufacture according to technical specifications and designs provided by the principal and following a production plan that sets the volumes and timing of product delivery, while the contract manufacturer is allocated a guaranteed remuneration irrespective of whether and if so at what price the principal is able to re-sell the products on the market. Although the day-to-day manufacturing would be carried on by the personnel of the contract manufacturer, the principal would be expected to make a number of relevant decisions in order to control its market and inventory risk, such as: the decision to hire (or terminate the contract with) that particular contract manufacturer, the decision of the type of products that should be manufactured, including their technical specifications, and the decision of the volumes to be manufactured by the contract manufacturer and of the timing of delivery. The principal would be expected to be able to assess the outcome of the manufacturing activities, including quality control of the manufacturing process and of the manufactured products. The contract manufacturer's own operational risk, e.g. the risk of losing a client or of suffering a penalty in case of negligence or failure to comply with the quality and other requirements set by the principal, is distinct from the market and inventory risks borne by the principal.

It should be borne in mind that there are also, as acknowledged at paragraph 1.49, risks over which neither party has significant control. There are risks which are typically beyond the scope of either party to influence (e.g. economic conditions, money and stock market conditions, political environment, social patterns and trends, competition and availability of raw materials and labour), although the parties can make a decision whether or not to expose themselves to those risks and whether and if so how to mitigate those risks. As far as risks over which neither party has significant control are concerned, control would not be a helpful factor in the determination of whether their allocation between the parties is arm's length.

### **2.7.7 Financial capacity to assume the risk**

Another relevant, although not determinative factor that can assist in the determination of whether a risk allocation in a controlled transaction is one which would have been agreed between independent parties in comparable circumstances is whether the risk-bearer has, at the time when risk is allocated to it, the financial capacity to assume (*i.e.* to take on) the risk.

Where risk is contractually assigned to a party (hereafter "the transferee") that does not have, at the time when the contract is entered into, the financial capacity to assume it, e.g. because it is anticipated that it will not have the capacity to bear the consequences of the risk should it materialise and that it also does not put in place a mechanism to cover it, doubts may arise as to whether the risk would be assigned to this party at arm's length. In effect, in such a situation, the risk may have to be effectively borne by the transferor, the parent company, creditors, or another party, depending on the facts and circumstances of the case, irrespective of the contractual terms that purportedly assigned it to the transferee.

This can be illustrated as follows. Assume that Company A bears product liability towards customers and enters into a contract with Company B according to which the latter will reimburse A for any claim that A may suffer in relation to such liability. The risk is contractually transferred from A to B. Assume now

that, at the time when the contract is entered into, Company B does not have the financial capacity to assume the risk, *i.e.* it is anticipated that B will not have the capacity to reimburse A, should a claim arise, and also does not put in place a mechanism to cover the risk in case it materialises. Depending on the facts and circumstances of the case, this may cause A to effectively bear the costs of the product liability risk materialising, in which case the transfer of risk from A to B would not be effective. Alternatively, it may be that the parent company of B or another party will cover the claim that A has on B, in which case the transfer of risk away from A would be effective (although the claim would not be reimbursed by B).

The financial capacity to assume the risk is not necessarily the financial capacity to bear the full consequences of the risk materialising, as it can be the capacity for the risk-bearer to protect itself from the consequences of the risk materialising. Furthermore, a high level of capitalisation by itself does not mean that the highly capitalised party carries risk.

### **2.7.8 Consequences of risk allocation**

In general, the consequence for one party of being allocated the risk associated with a controlled transaction, where such a risk allocation is found to be consistent with the arm's length principle, is that such party should:

- a) Bear the costs, if any, of managing (whether internally or by using associated or independent service providers) or mitigating the risk (*e.g.* costs of hedging, or insurance premium),
- b) Bear the costs that may arise from the realisation of the risk. This also includes, where relevant, the anticipated effects on asset valuation (*e.g.* inventory valuation) and / or the booking of provisions, subject to the application of the relevant domestic accounting and tax rules; and
- a) Generally be compensated by an increase in the expected return.

The reallocation of risks amongst associated enterprises can lead to both positive and negative effects for the transferor and for the transferee: on the one hand, potential losses and possible liabilities may, as a result of the transfer, shift to the transferee; on the other hand, the expected return attached to the risk transferred may be realised by the transferee rather than the transferor.

One important issue is to assess whether a risk is economically significant, *i.e.* it carries significant profit potential, and, as a consequence, whether the reallocation of that risk may explain a significant reallocation of profit potential. The significance of a risk will depend on its size, the likelihood of its realisation and its predictability, as well as on the possibility to mitigate it. If a risk is assessed to be economically insignificant, then the bearing or reallocation of that risk would not ordinarily explain a substantial amount of or decrease in the entity's profit potential. At arm's length a party would not be expected to transfer a risk that is perceived as economically insignificant in exchange for a substantial decrease in its profit potential.

For instance, where a buy-sell distributor which is converted into a commissionaire transfers the ownership of inventory to an overseas principal and where this transfer leads to a transfer of inventory risk, the tax administration would want to assess whether the inventory risk that is transferred is economically significant. It may want to ask:

- ❖ What the level of investment in inventory is,
- ❖ What the history of stock obsolescence is,
- ❖ What the cost of insuring it is, and
- ❖ What the history of loss in transit (if uninsured) is.

Accounting statements may provide useful information on the probability and quantum of certain risks (*e.g.* bad debt risks, inventory risks), but there are also economically significant risks that may not be recorded as such in the financial accounts (*e.g.* market risks).

Can the use of a transfer pricing method create a low risk environment?

The question of the relationship between the choice of a particular transfer pricing method and the level of risk left with the entity that is remunerated using that method is an important one in the context of business restructuring. It is quite commonly argued that because an arrangement is remunerated using a cost plus or TNMM that guarantees a certain level of gross or net profit to one of the parties, that party operates in a low risk environment. In this regard, one should distinguish between, on the one hand, the pricing arrangement according to which prices and other financial conditions of a transaction are contractually set and, on the other hand, the transfer pricing method that is used to test whether the price, margin or profits from a transaction are arm's length.

With respect to the former, the terms on which a party to a transaction is compensated cannot be ignored in evaluating the risk borne by that party. In effect, the pricing arrangement can directly affect the allocation of certain risks between the parties and can in some cases create a low risk environment. For instance, a manufacturer may be protected from the risk of price fluctuation of raw material as a consequence of its being remunerated on a cost plus basis that takes account of its actual costs. On the other hand, there can also be some risks the allocation of which does not derive from the pricing arrangement. For instance, remunerating a manufacturing activity on a cost plus basis may not as such affect the allocation of the risk of termination of the manufacturing agreement between the parties.

Concerning the transfer pricing method used to test the prices, margins or profits from the transaction, it should be the most appropriate transfer pricing method to the circumstances of the case. In particular, it should be consistent with the allocation of risk between the parties (provided such allocation of risk is arm's length), as the risk allocation is an important part of the functional analysis of the transaction. Thus, it is the low (or high) risk nature of a business that will dictate the selection of the most appropriate transfer pricing method, and not the contrary.

### **Part II: Arm's length compensation for the restructuring itself**

A business restructuring may involve cross-border transfers of something of value, e.g. of valuable intangibles, although this is not always the case. It may also or alternatively involve the termination or substantial renegotiation of existing arrangements, e.g. manufacturing arrangements, distribution arrangements, licenses, service agreements, etc.

Under Article 9 of the OECD Model Tax Convention, where the conditions made or imposed in a transfer of functions, assets and/or risks, and/or in the termination or renegotiation of a contractual relationship between two associated enterprises located in two different countries differ from those that would be made or imposed between independent enterprises, then any profits which would, but for those conditions, have accrued to one of the enterprises, but, by reason of those conditions, have not so accrued, may be included in the profits of that enterprise and taxed accordingly.

Understanding the restructuring itself

The determination of whether the conditions made or imposed in a business restructuring transaction are arm's length will generally be informed by a comparability analysis, and in particular by an examination of the functions performed, assets used and risks assumed by the parties, as well as of the contractual terms, economic circumstances and business strategies.

Where uncontrolled transactions that are potentially comparable to the restructuring transactions are identified, the comparability analysis will also aim at assessing the reliability of the comparison and, where needed and possible, at determining reasonably accurate comparability adjustments to eliminate the material effects of differences that may exist between the situations being compared.

It may be that comparable uncontrolled transactions for a restructuring transaction between associated enterprises are not found. This does not of itself mean that the restructuring is not arm's length, but it is still necessary to establish whether it satisfies the arm's length principle. In such cases, determining whether independent parties might be expected to have agreed to the same conditions in comparable circumstances may be usefully informed by a review of:

- ❖ The restructuring transactions and the functions, assets and risks before and after the restructuring;
- ❖ The business reasons for and the expected benefits from the restructuring, including the role of synergies;
- ❖ The options realistically available to the parties.

### **1) Identifying the restructuring transactions: functions, assets and risks before and after the restructuring**

Restructurings can take a variety of different forms and may involve only two or more than two members of an MNE group. For example, a simple pre-restructuring arrangement could involve a full-fledged manufacturer producing goods and selling them to an associated full-fledged distributor for on-sale into the market. The restructuring could involve a modification to that two-party arrangement, whereby the distributor is converted to a limited risk distributor or commissionnaire, with risks previously borne by the full-fledged distributor being assumed by the manufacturer. Frequently, the restructuring will be more complicated, with functions performed, assets used and/or risks assumed by either or both parties to a pre-restructuring arrangement shifting to one or more additional members of the group.

In order to determine the arm's length compensation payable upon a restructuring to any restructured entity within an MNE group, as well as the member of the group that should bear such compensation, it is important to identify the transaction or transactions occurring between the restructured entity and one or more other members of the group. This analysis will typically include an identification of the functions, assets and risks before and after the restructuring. It may be important to perform an evaluation of the rights and obligations of the restructured entity under the pre-restructuring arrangement (including in relevant circumstances those existing under contract and commercial law) and of the manner and extent to which those rights and obligations change as a result of the restructuring.

Obviously, any evaluation of the rights and obligations of the restructured entity must be based upon the requirement that those rights and obligations reflect the economic principles that generally govern relationships between independent enterprises. For example, a restructured entity may legally be under a short term or "at will" contractual arrangement at the time of the restructuring. However, the actual conduct of the entity in the years or decades prior to the restructuring may be indicative of a longer-term arrangement, and hence greater rights than those indicated by the legal contractual arrangement.

In the absence of evidence of rights and obligations in a comparable situation, it may be necessary to determine what rights and obligations would have been put in place had the two parties transacted with each other at arm's length. In making such an evaluation, care must be taken to avoid the use of hindsight.

### **2) Understanding the business reasons for and the expected benefits from the restructuring, including the role of synergies**

Business representatives who participated in the OECD consultation process explained that multinational businesses, regardless of their products or sectors, increasingly needed to reorganize their structures to provide more centralized control and management of manufacturing, research and distribution functions. The pressure of competition in a globalised economy, savings from economies of scale, the need for specialization and the need to increase efficiency and lower costs were all described as important in driving business restructuring. Where anticipated synergies are put forward by a taxpayer as an important business reason for the restructuring, it would be a good practice for the taxpayer to document, at the time the restructuring is decided upon or implemented, what these anticipated synergies are and on what assumptions they are anticipated. This is a type of documentation that is likely to be produced at the group level for non-tax purposes, to support the decision-making process of the restructuring. It would be a good practice for the taxpayer to document how these anticipated synergies impact at the entity level in applying the arm's length principle. Furthermore, while anticipated synergies may be relevant to the understanding of a business restructuring, care must be taken to avoid the use of hindsight in *ex post* analyses.

The fact that a business restructuring may be motivated by anticipated synergies does not necessarily mean that the profits of the MNE group will effectively increase after the restructuring. It may be the case that enhanced synergies make it possible for the MNE group to derive additional profits compared to what the situation would have been in the future if the restructuring had not taken place, but there may not necessarily be additional profits compared to the pre-restructuring situation, for instance if the restructuring is needed to maintain competitiveness rather than to increase it. In addition, expected synergies do not always materialise – there can be cases where the implementation of a global business model designed to derive more group synergies in fact leads to additional costs and less efficiency.

### **3) Other options realistically available to the parties**

The application of the arm's length principle is based on the notion that independent enterprises, when evaluating the terms of a potential transaction, will compare the transaction to the other options realistically available to them, and they will only enter into the transaction if they see no alternative that is clearly more attractive. In other words, independent enterprises would only enter into a transaction if it does not make them worse off than their next best option. Consideration of the other options realistically available may be relevant to comparability analysis, to understand the respective positions of the parties.

Thus, in applying the arm's length principle, a tax administration evaluates each transaction as structured by the taxpayer, unless such transaction is not recognised. However, alternative structures realistically available are considered in evaluating whether the terms of the controlled transaction (particularly pricing) would be acceptable to an uncontrolled taxpayer faced with the same alternatives and operating under comparable circumstances. If a more profitable structure could have been adopted, but the economic substance of the taxpayer's structure does not differ from its form and the structure is not commercially irrational such that it would practically impede a tax administration from determining an appropriate transfer price, the transaction is not disregarded. However, the consideration in the controlled transaction may be adjusted by reference to the profits that could have been obtained in the alternative structure, since independent enterprises will only enter into a transaction if they see no alternative that is clearly more attractive.

At arm's length, there are situations where an entity would have had one or more options realistically available to it that would be clearly more attractive than to accept the conditions of the restructuring (taking into account all the relevant conditions, including the commercial and market conditions going forward, the profit potential of the various options and any compensation or indemnification for the restructuring), including possibly the option not to enter into the restructuring transaction. In such cases, an independent party may not have agreed to the conditions of the restructuring.

At arm's length, there are also situations where the restructured entity would have had no clearly more attractive option realistically available to it than to accept the conditions of the restructuring, e.g. a contract termination – with or without indemnification. In longer-term contracts, this may occur by invoking an exit clause that allows for one party to prematurely exit the contract with just cause. In contracts that allow either party to opt out of the contract, the party terminating the arrangement may choose to do so because it has determined, subject to the terms of the termination clause, that it is more favourable to stop using the function, or to internalise it, or to engage a cheaper or more efficient provider (recipient) or to seek more lucrative opportunities (provider).

The arm's length principle requires an evaluation of the conditions made or imposed between associated enterprises, at the level of each of them. The fact that the cross-border redeployment of functions, assets and/or risks may be motivated by sound commercial reasons at the level of the MNE group, e.g. in order to try to derive synergies at a group level, does not answer the question whether it is arm's length from the perspectives of each of the restructured entities.

The reference to the notion of options realistically available is not intended to create a requirement for taxpayers to document all possible hypothetical options realistically available. It may be noted that,

when undertaking a comparability analysis, there is no requirement for an exhaustive search of all possible relevant sources of information. Rather, the intention is to provide an indication that, if there is a realistically available option that is clearly more attractive, it should be considered in the analysis of the conditions of the restructuring.

#### **4) Reallocation of profit potential as a result of a business restructuring**

##### **a) Profit potential**

An independent enterprise does not necessarily receive compensation when a change in its business arrangements results in a reduction in its profit potential or expected future profits. The arm's length principle does not require compensation for a mere decrease in the expectation of an entity's future profits. When applying the arm's length principle to business restructurings, the question is whether there is a transfer of something of value (rights or other assets) or a termination or substantial renegotiation of existing arrangements and that transfer, termination or substantial renegotiation would be compensated between independent parties in comparable circumstances.

Here, "profit potential" means "expected future profits". In some cases it may encompass losses. The notion of "profit potential" is often used for valuation purposes, in the determination of an arm's length compensation for a transfer of intangibles or of an ongoing concern, or in the determination of an arm's length indemnification for the termination or substantial renegotiation of existing arrangements, once it is found that such compensation or indemnification would have taken place between independent parties in comparable circumstances.

In the context of business restructurings, profit potential should not be interpreted as simply the profits/losses that would occur if the pre-restructuring arrangement were to continue indefinitely. On the one hand, if an entity has no discernable rights and/or other assets at the time of the restructuring, then it has no compensable profit potential. On the other hand, an entity with considerable rights and/or other assets at the time of the restructuring may have considerable profit potential, which must ultimately be appropriately remunerated in order to justify the sacrifice of such profit potential.

In order to determine whether at arm's length the restructuring itself would give rise to a form of compensation, it is essential to understand the restructuring, including the changes that have taken place, how they have affected the functional analysis of the parties, what the business reasons for and the anticipated benefits from the restructuring were, and what options would have been realistically available to the parties.

##### **b) Reallocation of risks and profit potential**

Business restructurings often involve changes in the respective risk profiles of the associated enterprises.

Take the example of a conversion of a full-fledged manufacturer into a contract manufacturer. In such a case, while a cost plus reward might be an arm's length remuneration for undertaking the post-restructuring contract manufacturing operations, a different question is whether there should be indemnification at arm's length for the change in the existing arrangements which results in the surrender of the riskier profit potential by the manufacturer, taking into account its rights and other assets.

As another example, assume a distributor is operating at its own risk under a long term contractual arrangement for a given type of transaction. Assume that, based on its rights under the long term contract with respect to these transactions, it has the option realistically available to it to accept or refuse being converted into a low risk distributor operating for a foreign associated enterprise, and that an arm's length remuneration for such a low risk distribution activity is estimated to be a stable profit of +2% per year while the excess profit potential associated with the risks would now be attributed to the foreign associated enterprise. Assume for the purpose of this example that such a restructuring would be implemented solely via a renegotiation of the existing contractual arrangements, with no transfer of assets taking place. From the perspective of the distributor, the question arises as to whether the new



arrangement (taking into account both the remuneration for the post-restructuring transactions and any compensation for the restructuring itself) would make it as well off as or better off than its realistic – albeit riskier – alternatives. If not, this would imply that the post-restructuring arrangement is mis-priced or that additional compensation would be needed to appropriately remunerate the distributor for the restructuring. From the perspective of the foreign associated enterprise, the question arises whether and if so to what extent it would be willing to accept the risk at arm's length in situations where the distributor continues to perform the same activity in a new capacity.

At arm's length, the response is likely to depend on the rights and other assets of the parties, on the profit potential of the distributor and of its associated enterprise in relation to both business models (full-fledged and low risk distributor) as well as the expected duration of the new arrangement. The perspective of the distributor can be illustrated with the following example.

In case no. 1, the distributor is surrendering a profit potential with significant uncertainties for a relatively low but stable profit. Whether an independent party would be willing to do so would depend on its anticipated return under both scenarios, on its level of risk tolerance, on its options realistically available and on possible compensation for the restructuring itself. In case no. 2, it is unlikely that independent parties in the distributor's situation would agree to relocate the risks and associated profit potential for no additional compensation if they had the option to do otherwise. Case no. 3 illustrates the fact that the analysis should take account of the profit potential going forward and that, where there is a significant change in the commercial or economic environment, relying on historical data alone will not be sufficient.

## **5) Transfer of something of value (e.g. an asset or an ongoing concern)**

### **a) Tangible assets**

Business restructurings can involve the transfer of tangible assets (e.g. equipment) by a restructured entity to a foreign associated enterprise. Although it is generally considered that transfers of tangible assets do not raise any significant transfer pricing difficulty, one common issue relates to the valuation of inventories that are transferred upon the conversion by a restructured manufacturer or distributor to a foreign associated enterprise (e.g. a principal), where the latter takes title to the inventories as from the implementation of the new business model and supply chain arrangements.

#### **Illustration**

Note: The following example is solely intended to illustrate the issue around valuation of inventory transfers. It is not intended to say anything about whether or not a particular restructuring should be recognised by tax authorities or whether or not it is consistent with the arm's length principle, nor is it intended to suggest that a particular transfer pricing method is always acceptable for restructured operations.

Assume a taxpayer, which is a member of an MNE group, used to operate as a "fully-fledged" manufacturer and distributor. According to the pre-restructuring business model, the taxpayer purchased raw materials, manufactured finished products using tangible and intangible property that belonged to it or was rented/licensed to it, performed marketing and distribution functions and sold the finished products to third party customers. In doing so, the taxpayer was bearing a series of risks such as inventory risks, bad debt risks and market risks.

Assume the arrangement is restructured and the taxpayer now operates as a so-called "toll-manufacturer" and "stripped distributor". As part of the restructuring, a foreign associated enterprise is established that acquires various trade and marketing intangibles from various affiliates including the taxpayer. Further to the restructuring, raw materials are to be acquired by the foreign associated enterprise, put in consignment in the premises of the taxpayer for manufacturing in exchange for a manufacturing fee. The stock of finished products will belong to the foreign associated enterprise and be acquired by the taxpayer for immediate re-sale to third party customers (*i.e.* the taxpayer will only purchase the finished products once it has concluded a sale with a customer). Under this new business

model, the foreign associated enterprise will bear the inventory risks that were previously borne by the taxpayer.

Assume that in order to migrate from the pre-existing arrangement to the restructured one, the raw materials and finished products that are on the balance sheet of the taxpayer at the time the new arrangement is put in place are transferred to the foreign associated enterprise. The question arises how to determine the arm's length transfer price for the inventories upon the conversion. This is an issue that can typically be encountered where there is a transition from one business model to another. The arm's length principle applies to transfers of inventory among associated enterprises situated in different tax jurisdictions. The choice of the appropriate transfer pricing method depends upon the comparability (including functional) analysis of the parties. The functional analysis may have to cover a transition period over which the transfer is being implemented. For instance, in the above example:

- ❖ One possibility could be to determine the arm's length price for the raw material and finished products by reference to comparable uncontrolled prices, to the extent the comparability factors can be met by such comparable uncontrolled prices, *i.e.* that the conditions of the uncontrolled transaction are comparable to the conditions of the transfer that takes place in the context of the restructuring.
- ❖ Another possibility could be to determine the transfer price for the finished products as the resale price to customers minus an arm's length remuneration for the marketing and distribution functions that still remain to be performed.
- ❖ A further possibility would be to start from the manufacturing costs and add an arm's length mark-up to remunerate the manufacturer for the functions it performed, assets it used and risks it assumed with respect to these inventories. There are however cases where the market value of the inventories is too low for a profit element to be added on costs at arm's length.

The choice of the appropriate transfer pricing method depends in part on which part of the transaction is the less complex and can be evaluated with the greater certainty (the functions performed, assets used and risks assumed by the manufacturer, or the marketing and sales functions that remain to be performed taking account of the assets to be used and risks to be assumed to perform these functions).

## **b) Intangible assets**

Transfers of intangible assets raise difficult questions both as to the identification of the assets transferred and as to their valuation. Identification can be difficult because not all valuable intangible assets are legally protected and registered and not all valuable intangible assets are recorded in the accounts. Relevant intangible assets might potentially include rights to use industrial assets such as patents, trademarks, trade names, designs or models, as well as copyrights of literary, artistic or scientific work (including software) and intellectual property such as know-how and trade secrets. They may also include customer lists, distribution channels, unique names, symbols or pictures. An essential part of the analysis of a business restructuring is to identify the significant intangible assets that were transferred (if any), whether independent parties would have remunerated their transfer, and what their arm's length value is.

The determination of the arm's length price for a transfer of intangible property right should take account of both the perspective of the transferor and of the transferee. It will be affected by a number of factors among which are the amount, duration and riskiness of the expected benefits from the exploitation of the intangible property, the nature of the property right and the restrictions that may be attached to it (restrictions in the way it can be used or exploited, geographical restrictions, time limitations), the extent and remaining duration of its legal protection (if any), and any exclusivity clause that might be attached to the right. Valuation of intangibles can be complex and uncertain. The general guidance on intangibles and on cost contribution arrangements that is found in Chapters VI and VIII can be applicable in the context of business restructurings.

**(i) Disposal of intangible rights by a local operation to a central location (foreign associated enterprise)**

Business restructurings sometimes involve the transfer of intangible assets that were previously owned and managed by one or more local operation(s) to a central location situated in another tax jurisdiction (e.g. a foreign associated enterprise that operates as a principal or as a so-called “IP company”). The intangible assets transferred may or may not be valuable for the transferor and/or for the MNE group as a whole. In some cases the transferor continues to use the intangible transferred, but does so in another legal capacity (e.g. as a licensee of the transferee, or through a contract that includes limited rights to the intangible such as a contract manufacturing arrangement using patents that were transferred; or a “stripped” distribution arrangement using a trademark that was transferred); in some other cases it does not.

MNE groups may have sound business reasons to centralize ownership and management of intangible property. An example in the context of business restructuring is a transfer of intangibles that accompanies the specialisation of manufacturing sites within an MNE group. In a pre-restructuring environment, each manufacturing entity may be the owner and manager of a series of patents – for instance if the manufacturing sites were historically acquired from third parties with their intangible property. In a global business model, each manufacturing site can be specialised by type of manufacturing process or by geographical area rather than by patent. As a consequence of such a restructuring the MNE group might proceed with the transfer of all the locally owned and managed patents to a central location which will in turn give contractual rights (through licences or manufacturing agreements) to all the group’s manufacturing sites to manufacture the products falling in their new areas of competence, using patents that were initially owned either by the same or by another entity within the group.

The arm’s length principle requires an evaluation of the conditions made or imposed between associated enterprises, at the level of each of them. The fact that centralisation of intangible property rights may be motivated by sound commercial reasons at the level of the MNE group does not answer the question whether the disposal is arm’s length from the perspectives of both the transferor and the transferee.

Also in the case where a local operation disposes of its intangible property rights to a foreign associated enterprise and continues to use the intangibles further to the disposal, but does so in a different legal capacity (e.g. as a licensee), the conditions of the transfer should be assessed from both the transferor’s and the transferee’s perspectives, in particular by examining the pricing at which comparable independent enterprises would be willing to transfer and acquire the property. See paragraph 9.81. The determination of an arm’s length remuneration for the subsequent ownership, use and exploitation of the transferred asset should take account of the extent of the functions performed, assets used and risks assumed by the parties in relation to the intangible transferred. This is particularly relevant to business restructurings as several countries have expressed a concern that relevant information on the functions, assets and risks of foreign associated enterprises is often not made available to them.

Where the business restructuring provides for a transfer of an intangible asset followed by a new arrangement whereby the transferor will continue to use the intangible transferred, the entirety of the commercial arrangement between the parties should be examined in order to assess whether the transactions are at arm’s length. If an independent party were to transfer an asset that it intends to continue exploiting, it would be prudent for it to negotiate the conditions of such a future use (e.g. in a license agreement) concomitantly with the conditions of the transfer. In effect, there will generally be a relationship between the determination of an arm’s length compensation for the transfer, the determination of an arm’s length compensation for the post-restructuring transactions in relation to the transferred intangible, such as future license fees that may be payable by the transferor to be able to continue using the asset, and the expected future profitability of the transferor from its future use of the asset. For instance, an arrangement whereby a patent is transferred for a price of 100 in Year N and a license agreement is concomitantly concluded according to which the transferor will continue to use the patent transferred in exchange for a royalty of 100 per year over a 10-year period is unlikely to be consistent with the arm’s length principle.

### **(ii) Intangible transferred at a point in time when it does not have an established value**

Difficulties can arise in the context of business restructuring where an intangible is disposed of at a point in time when it does not yet have an established value (e.g. pre-exploitation), especially where there is a significant gap between the level of expected future profits that was taken into account in the valuation made at the time of the sale transaction and the actual profits derived by the transferee from the exploitation of the intangibles thus acquired. When valuation of intangible property at the time of the transaction is highly uncertain, the question is raised how arm's length pricing should be determined. The question should be resolved, both by taxpayers and tax administrations, by reference to what independent enterprises would have done in comparable circumstances to take account of the valuation uncertainty in the pricing of the transaction.

Following that guidance, the main question is to determine whether the valuation was sufficiently uncertain at the outset that the parties at arm's length would have required a price adjustment mechanism, or whether the change in value was so fundamental a development that it would have led to a renegotiation of the transaction. Where this is the case, the tax administration would be justified in determining the arm's length price for the transfer of the intangible on the basis of the adjustment clause or re-negotiation that would be provided at arm's length in a comparable uncontrolled transaction. In other circumstances, where there is no reason to consider that the valuation was sufficiently uncertain at the outset that the parties would have required a price adjustment clause or would have renegotiated the terms of the agreement, there is no reason for tax administrations to make such an adjustment as it would represent an inappropriate use of hindsight. The mere existence of uncertainty at the time of the transaction should not require an *ex-post* adjustment without a consideration of what third parties would have done or agreed between them.

### **(iii) Local intangibles**

Where a local full-fledged operation is converted into a "limited risk, limited intangibles, low remuneration" operation, the questions arise of whether this conversion entails the transfer by the restructured local entity to a foreign associated enterprise of valuable intangible assets such as customer lists and whether there are local intangible assets that remain with the local operation.

In particular, in the case of the conversion of a full-fledged distributor into a limited risk distributor or commissionaire, it may be important to examine whether the distributor has developed local marketing intangibles over the years prior to it being restructured and if so, what the nature and the value of these intangibles are, and whether they were transferred to an associated enterprise. Where such local intangibles are found to be in existence and to be transferred to a foreign associated enterprise, the arm's length principle should apply to determine whether and if so how to compensate such a transfer, based on what would be agreed between independent parties in comparable circumstances. On the other hand, where such local intangibles are found to be in existence and to remain in the restructured entity, they should be taken into account in the functional analysis of the post-restructuring activities. They may accordingly influence the selection and application of the most appropriate transfer pricing method for the post-restructuring controlled transactions, and / or be remunerated separately, e.g. via royalty payments made by the foreign associated enterprise which will exploit them as from the restructuring to the restructured entity over the life-span of the intangibles.<sup>4</sup>

### **(iv) Contractual rights**

Contractual rights can be valuable intangible assets. Where valuable contractual rights are transferred (or surrendered) between associated enterprises, they should be remunerated at arm's length, taking account of the value of the rights transferred from the perspectives of both the transferor and the transferee.

Tax administrations have expressed concerns about cases they have observed in practice where an entity voluntarily terminates a contract that provided benefits to it, in order to allow a foreign associated enterprise to enter into a similar contract and benefit from the profit potential attached to it. For instance, assume that company A has valuable long-term contracts with independent customers that

carry significant profit potential for A. Assume that at a certain point in time, A voluntarily terminates its contracts with its customers under circumstances where the latter are legally or commercially obligated to enter into similar arrangements with company B, a foreign entity that belongs to the same MNE group as A. As a consequence, the contractual rights and attached profit potential that used to lie with A now lie with B. If the factual situation is that B could only enter into the contracts with the customers subject to A's surrendering its own contractual rights to its benefit, and that A only terminated its contracts with its customers knowing that the latter were legally or commercially obligated to conclude similar arrangements with B, this in substance would consist in a tri-partite transaction and it may amount to a transfer of valuable contractual rights from A to B that may have to be remunerated at arm's length, depending on the value of the rights surrendered by A from the perspectives of both A and B.

## **6) Transfer of activity (ongoing concern)**

### **(a) Valuing a transfer of activity**

Business restructurings sometimes involve the transfer of an ongoing concern, *i.e.* a functioning, economically integrated business unit. The transfer of an ongoing concern in this context means the transfer of assets, bundled with the ability to perform certain functions and bear certain risks. Such functions, assets and risks may include, among other things: tangible and intangible property; liabilities associated with holding certain assets and performing certain functions, such as R&D and manufacturing; the capacity to carry on the activities that the transferor carried on before the transfer; and any resource, capabilities, and rights. The valuation of a transfer of an ongoing concern should reflect all the valuable elements that would be remunerated between independent parties in comparable circumstances. For example, in the case of a business restructuring that involves the transfer of a business unit that includes, among other things, research facilities staffed with an experienced research team, the valuation of such ongoing concern should reflect, among other things, the value of the facility and the value (if any) of the workforce in place that would be agreed upon at arm's length.

The determination of the arm's length compensation for a transfer of an ongoing concern does not necessarily amount to the sum of the separate valuations of each separate element that comprises the aggregate transfer. In particular, if the transfer on an ongoing concern comprises multiple contemporaneous transfers of interrelated assets, risks, or functions, valuation of those transfers on an aggregate basis may be necessary to achieve the most reliable measure of the arm's length price for the ongoing concern. Valuation methods that are used, in acquisition deals, between independent parties may prove useful to valuing the transfer of an ongoing concern between associated enterprises.

An example is the case where a manufacturing activity that used to be performed by M1, one entity of the MNE group, is re-located to another entity, M2 (e.g. to benefit from location savings). Assume M1 transfers to M2 its machinery and equipment, inventories, patents, manufacturing processes and know-how, and key contracts with suppliers and clients. Assume that several employees of M1 are relocated to M2 in order to assist M2 in the start of the manufacturing activity so relocated. Assume such a transfer would be regarded as a transfer of an ongoing concern, should it take place between independent parties. In order to determine the arm's length remuneration, if any, of such a transfer between associated enterprises, it should be compared with a transfer of an ongoing concern between independent parties rather than with a transfer of isolated assets.

### **(b) Loss-making activities**

Not every case where a restructured entity loses functions, assets and / or risks involves an actual loss of expected future profits. In some restructuring situations, the circumstances may be such that, rather than losing a "profit-making opportunity", the restructured entity is actually being saved from the likelihood of a "loss-making opportunity". An entity may agree to a restructuring and a loss of functions, assets and / or risks as a better option than going out of business altogether. If the restructured entity is forecasting future losses absent the restructuring (e.g. it operates a manufacturing plant that is uneconomic due to increasing competition from low-cost imports), then there may be in fact no loss of any profit-making opportunity from restructuring rather than continuing to operate its existing business.

In such circumstances, the restructuring might deliver a benefit to the restructured entity from reducing or eliminating future losses if such losses exceed the restructuring costs.

The question was raised of whether the transferee should in fact be compensated by the transferor for taking over a loss-making activity. The response depends on whether an independent party in comparable circumstances would have been willing to pay for getting rid of the loss-making activity, or whether it would have considered other options such as closing down the activity; and on whether a third party would have been willing to acquire the loss-making activity (e.g. because of possible synergies with its own activities) and if so under what conditions, e.g. subject to compensation. There can be circumstances where an independent party would be willing to pay, e.g. if the financial costs and social risks of closing down the activity would be such that the transferor finds it more advantageous to pay a transferee who will attempt to reconvert the activity and will be responsible for any redundancy plan that may be needed.

The situation might however be different where the loss-making activity provided other benefits such as synergies with other activities performed by the same taxpayer. There can also be circumstances where a loss-making activity is maintained because it produces some benefits to the group as a whole. In such a case, the question arises whether at arm's length the entity that maintains the loss-making activity should be compensated by those who benefit from it being maintained.

### **(c) Outsourcing**

In outsourcing cases, it may happen that a party voluntarily decides to undergo a restructuring and to bear the associated restructuring costs in exchange for anticipated savings. For instance, assume a taxpayer that is manufacturing and selling products in a high-cost jurisdiction decides to outsource the manufacturing activity to an associated enterprise situated in a low-cost jurisdiction. Further to the restructuring, the taxpayer will purchase from its associated enterprise the products manufactured and will continue to sell them to third party customers. The restructuring may entail restructuring costs for the taxpayer while at the same time making it possible for it to benefit from cost savings on future procurements compared to its own manufacturing costs. Independent parties implement this type of outsourcing arrangement and do not necessarily require explicit compensation from the transferee if the anticipated cost savings for the transferor are greater than its restructuring costs.

### **7) Indemnification of the restructured entity for the termination or substantial renegotiation of existing arrangements**

Where an existing contractual relationship is terminated or substantially renegotiated in the context of a business restructuring, the restructured entity might suffer detriments such as restructuring costs (e.g. write-off of assets, termination of employment contracts), re-conversion costs (e.g. in order to adapt its existing operation to other customer needs), and/or a loss of profit potential. In business restructurings, existing arrangements are often renegotiated in such a way that the respective risk profiles of the parties are changed, with consequences on the allocation of profit potential among them. For instance, a full-fledged distribution arrangement is converted into a low-risk distribution or commissionaire arrangement; a full-fledged manufacturing arrangement is converted into a contract-manufacturing or toll-manufacturing arrangement. In these situations, the question arises of whether independent parties in similar circumstances would have agreed for an indemnification to be paid to the restructured entity (and if so how to determine such an indemnification).

The renegotiation of existing arrangements is sometimes accompanied by a transfer of rights or other assets. For instance, the termination of a distribution contract is sometimes accompanied by a transfer of intangibles.

For the purpose of this chapter, indemnification means any type of compensation that may be paid for detriments suffered by the restructured entity, whether in the form of an up-front payment, of a sharing in restructuring costs, of lower (or higher) purchase (or sale) prices in the context of the post-restructuring operations, or of any other form.

There should be no presumption that all contract terminations or substantial renegotiations should give a right to indemnification at arm's length. In order to assess whether an indemnification would be warranted at arm's length, it is important to examine the circumstances at the time of the restructuring, particularly the rights and other assets of the parties as well as, where relevant, the options realistically available to the parties. For this purpose, the following four conditions may be important:

- ❖ Whether the arrangement that is terminated, non-renewed or substantially re-negotiated is formalised in writing and provides for an indemnification clause;
- ❖ Whether the terms of the arrangement and the existence or non-existence of an indemnification clause or other type of guarantee (as well as the terms of such a clause where it exists) are arm's length;
- ❖ Whether indemnification rights are provided for by commercial legislation or case law; and
- ❖ Whether at arm's length another party would have been willing to indemnify the one that suffers from the termination or re-negotiation of the agreement.

**8) Whether the arrangement that is terminated, non-renewed or substantially renegotiated is formalised in writing and provides for an indemnification clause**

Where the terminated, non-renewed or re-negotiated arrangement is formalised in writing, the starting point of the analysis should be a review of whether the conditions for termination, non-renewal or renegotiation of the contract were respected (e.g. with regard to any required notice period) and of whether an indemnification clause or other kind of guarantee for termination, non-renewal or renegotiation is provided for. In transactions between independent enterprises, the divergence of interests between the parties ensures that they will ordinarily seek to hold each other to the terms of the contract, and that contractual term will be ignored or modified after the fact generally only if it is in the interests of both parties.

However, the examination of the terms of the contract between the associated enterprises may not suffice from a transfer pricing perspective as the mere fact that a given terminated, non-renewed or renegotiated contract did not provide an indemnification or guarantee clause does not necessarily mean that this is arm's length, as discussed below.

**9) Whether the terms of the arrangement and the existence or non-existence of an indemnification clause or other type of guarantee (as well as the terms of such a clause where it exists) are arm's length**

Between independent parties, there are cases of contracts that are terminated, non-renewed or substantially renegotiated with no indemnification. However, because the same divergence of interests that exists between independent parties may not exist in the case of associated enterprises, the question can arise whether the terms of a contract between associated enterprises are arm's length, *i.e.* whether independent parties in comparable conditions would have concluded such a contract (for instance a contract that contains no indemnification clause or guarantee of any kind in case of termination, non-renewal or renegotiation). Where comparables data evidence a similar indemnification clause (or absence thereof) in comparable circumstances, the indemnification clause (or absence thereof) in a controlled transaction will be regarded as arm's length. In those cases however where such comparables data are not found, the determination of whether independent parties would have agreed to such an indemnification clause (or absence thereof) should take into account the rights and other assets of the parties, at the time of entering into the arrangement and of its termination or renegotiation, and might be assisted by an examination of the options realistically available to the parties.

When examining whether the conditions of an arrangement are arm's length, it may be necessary to examine both the remuneration of the transactions that are the object of the arrangement and the financial conditions of the termination thereof, as both can be inter-related. In effect, the terms of a termination clause (or the absence thereof) may be a significant element of the functional analysis of the transactions and specifically of the analysis of the risks of the parties, and may accordingly need

to be taken into account in the determination of an arm's length remuneration for the transactions. Similarly, the remuneration of the transactions will affect the determination of whether the conditions of the termination of the arrangement are at arm's length.

In some situations, it may be the case that, in comparable circumstances, an independent party would not have had any option realistically available that would be clearly more attractive to it than to accept the conditions of the termination or substantial renegotiation of the contract. In some other cases, it may be that, on the basis of an examination of the substance of the arrangement and of the actual conduct of the associated enterprises, an implicit longer term contract should be implied whereby the terminated party would have been entitled to some indemnification in case of early termination.

One circumstance that deserves particular attention, because it could have influenced the terms of the contract had it been concluded between independent parties, is the situation where the now-terminated contract required one party to make a significant investment for which an arm's length return might only be reasonably expected if the contract was maintained for an extended period of time. This created a financial risk for the party making the investment in case the contract was terminated before the end of such period of time. The degree of the risk would depend on whether the investment was highly specialised or could be used (possibly subject to some adaptations) for other clients. Where the risk was material, it would have been reasonable for independent parties in comparable circumstances to take it into account when negotiating the contract.

An example would be where a manufacturing contract between associated enterprises requires the manufacturer to invest in a new manufacturing unit. Assume an arm's length return on the investment can reasonably be anticipated by the manufacturer at the time the contract is concluded, subject to the manufacturing contract lasting for at least five years, for the manufacturing activity to produce at least  $x$  units per year, and for the remuneration of the manufacturing activity to be calculated on a basis (e.g.  $y\$/unit$ ) that is expected to generate an arm's length return on the total investment in the new manufacturing unit. Assume that after three years, the associated enterprise terminates the contract in accordance with its terms in the context of a group-wide restructuring of the manufacturing operations. Assume the manufacturing unit is highly specialised and the manufacturer further to the termination has no other choice than to write off the assets. The question arises of whether in comparable circumstances, an independent manufacturer in the first place would have sought to mitigate the financial risk linked to the investment in case of termination of its manufacturing contract before the end of the five-year period it needed to obtain an arm's length return on its investment.

The general guidance in Part I of this chapter on how to determine whether a risk allocation is arm's length would be relevant in such a case. In case comparable uncontrolled transactions are found that evidence a similar allocation of risks in uncontrolled transactions (taking account in particular the conditions of the investment, the remuneration of the manufacturing activity and the conditions of the termination), then the risk allocation between the associated enterprises would be regarded as arm's length.

In case such evidence is not found, the question would be whether independent parties would have agreed to a similar allocation of risk. This will depend on the facts and circumstances of the transaction and in particular on the rights and other assets of the parties.

- ❖ At arm's length the party making the investment might not be willing to assume with no guarantee a risk (termination risk) that is controlled by the other. There can be a variety of ways in which such a risk might have been taken into account in contract negotiations, for instance by providing for an appropriate indemnification clause in case of early termination, or for an option for the party making the investment to transfer it at a given price to the other party in case the investment becomes useless to the former due to the early termination of the contract by the latter.
- ❖ Another possible approach would have been to factor the risk linked with the possible termination of the contract into the determination of the remuneration of the activities covered by the contract (e.g. by factoring the risk into the determination of the remuneration of the manufacturing activities



and using third party comparables that bear comparable risks). In such a case the party making the investment consciously accepts the risk and is rewarded for it; no separate indemnification for the termination of the contract seems necessary.

- ❖ Finally, in some cases, the risks might be shared between the parties, e.g. the party terminating the contract might bear part of the termination costs incurred by the terminated one.

A similar issue may arise in the case where a party has undertaken development efforts resulting in losses or low returns in the early period and above-normal returns are expected in periods following the termination of the contract.

In the case where the conditions made or imposed between associated enterprises with respect to the termination, non-renewal or substantial renegotiation of their existing arrangements differ from the conditions that would be made between independent enterprises, then any profits that would, but for those conditions, have accrued to one of the enterprises, but, by reason of those conditions, have not so accrued, may be included in the profits of that enterprise and taxed accordingly.

#### **10) Whether indemnification rights are provided for by commercial legislation or case law**

In the assessment of whether the conditions of the termination or non-renewal of an existing arrangement are arm's length, the possible recourse that may be offered by the applicable commercial law might provide some helpful insights. The applicable commercial legislation or case law may provide useful information on indemnification rights and terms and conditions that could be expected in case of termination of specific types of agreements, e.g. of a distributorship agreement. Under such rules, it may be that the terminated party has the right to claim before the courts an indemnification irrespective of whether or not it was provided for in the contract. Where the parties belong to the same MNE group, however, the terminated party is unlikely in practice to litigate against its associated enterprise in order to seek such an indemnification, and the conditions of the termination may therefore differ from the conditions that would be made between independent enterprises in similar circumstances.

#### **11) Whether at arm's length another party would have been willing to indemnify the one that suffers from the termination or re-negotiation of the agreement**

The transfer pricing analysis of the conditions of the termination or substantial renegotiation of an agreement should take account of both the perspectives of the transferor and of the transferee. Taking account of the transferee's perspective is important both to value the amount of an arm's length indemnification, if any, and to determine what party should bear it. It is not possible to derive a single answer for all cases and the response should be based on an examination of the facts and circumstances of the case, and in particular of the rights and other assets of the parties, of the economic rationale for the termination, of the determination of what party(ies) is (are) expected to benefit from it, and of the options realistically available to the parties. This can be illustrated as follows.

### **Part III: Remuneration of post-restructuring controlled transactions**

#### **1) Business restructurings versus "structuring"**

##### **a) General principle: no different application of the arm's length principle**

The arm's length principle and these Guidelines do not and should not apply differently to post-restructuring transactions as opposed to transactions that were structured as such from the beginning. Doing otherwise would create a competitive distortion between existing players who restructure their activities and new entrants who implement the same business model without having to restructure their business.

Comparable situations must be treated in the same way. The selection and practical application of an appropriate transfer pricing method must be determined by the comparability analysis, including the functional analysis of the parties and a review of the contractual arrangements. The same comparability standard and the same guidance on the selection and application of transfer pricing methods apply

irrespective of whether or not an arrangement came into existence as a result of a restructuring of a previously existing structure.

However, business restructuring situations involve change, and the arm's length principle must be applied not only to the post-restructuring transactions, but also to additional transactions that take place upon the restructuring and consist in the redeployment of functions, assets and/or risks. The application of the arm's length principle to those additional transactions is discussed in Part II of this chapter.

In addition, the comparability analysis of an arrangement that results from a business restructuring might reveal some factual differences compared to the one of an arrangement that was structured as such from the beginning, as discussed below. These factual differences do not affect the arm's length principle or the way the guidance in these Guidelines should be interpreted and applied, but they may affect the comparability analysis and therefore the outcome of this application. See Section D on comparing the pre- and post-restructuring situations.

**b) Possible factual differences between situations that result from a restructuring and situations that were structured as such from the beginning**

Where an arrangement between associated enterprises replaces an existing arrangement (restructuring), there may be factual differences in the starting position of the restructured entity compared to the position of a newly set up operation. Such differences can arise for example from the fact that the post-restructuring arrangement is negotiated between parties that have had prior contractual and commercial relationships. In such a situation, depending on the facts and circumstances of the case and in particular on the rights and obligations derived by the parties from these prior arrangements, this may affect the options realistically available to the parties in negotiating the terms of the new arrangement and therefore the conditions of the restructuring and / or of the post-restructuring arrangements. For instance, assume a party has proved in the past to be able to perform well as a "full-fledged distributor" performing a whole range of marketing and selling functions, employing and developing valuable marketing intangible assets and assuming a range of risks associated with its activity such as inventory risks, bad debt risks and market risks. Assume that its distribution contract is re-negotiated and converted into a "limited risk distribution" contract whereby it will perform limited marketing activities under the supervision of a foreign associated enterprise, employ limited marketing intangibles and bear limited risks in its relationship with the foreign associated enterprise and customers. The restructured distributor may be able to negotiate an arrangement that does not contain a trial period or other similar unfavourable conditions, while such a trial period or conditions may be common for new distributors.

Where there is an ongoing business relationship between the parties before and after the restructuring, there may also be an inter-relationship between on the one hand the conditions of the pre-restructuring activities and/or of the restructuring itself, and on the other hand the conditions for the post-restructuring arrangements, as discussed in Section C below.

Some differences in the starting position of the restructured entity compared to the position of a newly set up operation can relate to the established presence of the operation. For instance, if one compares a situation where a long-established "full-fledged distributor" is converted into a "limited risk distributor" with a situation where a "limited risk distributor" is established in a market where the group did not have any previous commercial presence, market penetration efforts might be needed for the new entrant which are not needed for the converted entity. This may affect the comparability analysis and the determination of the arm's length remuneration in both situations.

When one compares a situation where a long-established "full-fledged distributor" is converted into a "limited risk distributor" with a situation where a "limited risk distributor" has been in existence in the market for the same duration, there might also be differences because the "full-fledged distributor" may have performed some functions, borne some expenses (e.g. marketing expenses), assumed some risks and contributed to the development of some intangibles before its conversion that the long-existing

“limited risk distributor” may not have performed, borne, assumed or contributed to. The question arises whether at arm’s length such additional functions, assets and risks should only affect the remuneration of the distributor before its being converted, whether they should be taken into account to determine a remuneration of the transfers that take place upon the conversion (and if so how), whether they should affect the remuneration of the restructured “limited risk distributor” (and if so how), or a combination of these three possibilities. For instance, if it is found that the pre-restructuring activities led the “full-fledged distributor” to own some intangibles while the long-established “limited risk distributor” does not, the arm’s length principle may require these intangibles either to be remunerated upon the restructuring if they are transferred by the “full-fledged distributor” to a foreign associated enterprise, or to be taken into account in the determination of the arm’s length remuneration of the post-restructuring activities if they are not transferred.

Where a restructuring involves a transfer to a foreign associated enterprise of risks that were previously assumed by a taxpayer, it may be important to examine whether the transfer of risks only concerns the future risks that will arise from the post-restructuring activities or also the risks existing at the time of the restructuring as a result of pre-conversion activities, *i.e.* there is a cut-off issue. For instance, assume that a distributor was bearing bad debt risks which it will no longer bear after its being restructured as a “limited risk distributor”, and that it is being compared with a long-established “limited risk distributor” that never bore bad debt risk. It may be important when comparing both situations to examine whether the “limited risk distributor” that results from a conversion still bears the risks associated with bad debts that arose before the restructuring at the time it was full-fledged, or whether all the bad debt risks including those that existed at the time of the conversion were transferred.

The same remarks and questions apply for other types of restructurings, including other types of restructuring of sales activities as well as restructurings of manufacturing activities, research and development activities, or other services activities.

## **2) Application to business restructuring situations: selection and application of a transfer pricing method for the post-restructuring controlled transactions**

The selection and application of a transfer pricing method to post-restructuring controlled transactions must derive from the comparability analysis of the transaction. It is essential to understand what the functions, assets and risks involved in the post-restructuring transactions are, and what party performs, uses or assumes them. This requires information to be available on the functions, assets and risks of both parties to a transaction, *e.g.* the restructured entity and the foreign associated enterprise with which it transacts. The analysis should go beyond the label assigned to the restructured entity, as an entity that is labelled as a “commissionnaire” or “limited distributor” can sometimes be found to own valuable local intangibles and to continue to assume significant market risks, and an entity that is labelled as a “contract manufacturer” can sometimes be found to pursue significant development activities or to own and use unique intangibles. In post-restructuring situations, particular attention should be paid to the identification of the valuable intangible assets and the significant risks that effectively remain with the restructured entity (including, where applicable, local non-protected intangibles), and to whether such an allocation of intangibles and risks satisfies the arm’s length principle. Issues regarding risks and intangibles are discussed in Parts I and II of this chapter.

Post-restructuring arrangements may pose certain challenges with respect to the identification of potential comparables in cases where the restructuring implements a business model that is hardly found between independent enterprises.

There are cases where comparables (including internal comparables) are available, subject to possible comparability adjustments being performed. One example of a possible application of the CUP method would be the case where an enterprise that used to transact independently with the MNE group is acquired, and the acquisition is followed by a restructuring of the now controlled transactions. Subject to a review of the five comparability factors and of the possible effect of the controlled and uncontrolled transactions taking place at different times, it might be the case that the conditions of the pre-acquisition uncontrolled transactions provide a CUP for the post-acquisition controlled



transactions. Even where the conditions of the transactions are restructured, it might still be possible, depending on the facts and circumstances of the case, to adjust for the transfer of functions, assets and/or risks that occurred upon the restructuring. For instance, a comparability adjustment might be performed to account for a difference in what party bears bad debt risk.

Another example of a possible application of the CUP method would be the case where independent parties provide manufacturing, selling or service activities comparable to the ones provided by the restructured affiliate. Given the recent development of outsourcing activities, it may be possible in some cases to find independent outsourcing transactions that provide a basis for using the CUP method in order to determine the arm's length remuneration of post-restructuring controlled transactions. This of course is subject to the condition that the outsourcing transactions qualify as uncontrolled transactions and that the review of the five comparability factors provides sufficient comfort that either no material difference exists between the conditions of the uncontrolled outsourcing transactions and the conditions of the post-restructuring controlled transactions, or that reliable enough adjustments can be made (and are effectively made) to eliminate such differences.

Whenever a comparable is proposed, it is important to ensure that a comparability analysis is performed in order to identify material differences, if any, between the controlled and uncontrolled transactions and, where necessary and possible, to adjust for such differences. In particular, the comparability analysis might reveal that the restructured entity continues to perform valuable and significant functions and/or the presence of local intangibles and/or of significant risks that remain in the "stripped" entity after the restructuring but are not found in the proposed comparables. See Section A on the possible differences between restructured activities and start-up situations.

The identification of potential comparables has to be made with the objective of finding the most reliable comparables data in the circumstances of the case, keeping in mind the limitations that may exist in availability of information and the compliance costs involved. It is recognised that the data will not always be perfect. There are also cases where comparables data are not found. This does not necessarily mean that the controlled transaction is not arm's length. In such cases, it may be necessary to determine whether the conditions of the controlled transaction would have been agreed, had the parties transacted with each other at arm's length. Notwithstanding the difficulties that can arise in the process of searching comparables, it is necessary to find a reasonable solution to all transfer pricing cases.

### **3) Relationship between compensation for the restructuring and post-restructuring remuneration**

There may in some circumstances be an important inter-relationship between the compensation for the restructuring and an arm's length reward for operating the business post-restructuring. This can be the case where a taxpayer disposes of business operations to an associated enterprise with which it must then transact business as part of those operations.

Another example would be where a taxpayer that operates a manufacturing and distribution activity restructures by disposing of its distribution activity to a foreign associated enterprise to which the taxpayer will in the future sell the goods it manufactures. The foreign associated enterprise would expect to be able to earn an arm's length reward for its investment in acquiring and operating the business. In this situation, the taxpayer might agree with the foreign associated enterprise to forgo receipt of part or all of the up-front compensation for the business that may be payable at arm's length, and instead obtain comparable financial benefit over time through selling its goods to the foreign associated enterprise at prices that are higher than the latter would otherwise agree to if the up-front compensation had been paid. Alternatively, the parties might agree to set an up-front compensation payment for the restructuring that is partly offset through future lower transfer prices for the manufactured products than would have been set otherwise. See Part II of this chapter for a discussion of situations where compensation would be payable at arm's length for the restructuring itself.

In other words, in this situation where the taxpayer will have an ongoing business relationship as supplier to the foreign associated enterprise that carries on an activity previously carried on by the taxpayer,

the taxpayer and the foreign associated enterprise have the opportunity to obtain economic and commercial benefits through that relationship (e.g. the sale price of goods) which may explain for instance why compensation through an up-front capital payment for transfer of the business was foregone, or why the future transfer price for the products might be different from the prices that would have been agreed absent a restructuring operation. In practice, however, it might be difficult to structure and monitor such an arrangement. While taxpayers are free to choose the form of compensation payments, whether up-front or over time, tax administrations when reviewing such arrangements would want to know how the compensation for the post-restructuring activity was possibly affected to take account of the foregone compensation, if any, for the restructuring itself. Specifically, in such a case, the tax administration would want to look at the entirety of the arrangements, while being provided with a separate evaluation of the arm's length compensation for the restructuring and for the post-restructuring transactions.

#### **4) Comparing the pre- and post-restructuring situations**

A relevant question is the role if any of comparisons that can be made of the profits actually earned by a party to a controlled transaction prior to and after the restructuring. In particular, it can be asked whether it would be appropriate to determine a restructured entity's post-restructuring profits by reference to its pre-restructuring profits, adjusted to reflect the transfer or relinquishment of particular functions, assets and risks.<sup>11</sup>

One important issue with such before-and-after comparisons is that a comparison of the profits from the post-restructuring controlled transactions with the profits made in controlled transactions prior to the restructuring would not suffice given Article 9 of the OECD Model Tax Convention provides for a comparison to be made with uncontrolled transactions. Comparisons of a taxpayer's controlled transactions with other controlled transactions are irrelevant to the application of the arm's length principle and therefore should not be used by a tax administration as the basis for a transfer pricing adjustment or by a taxpayer to support its transfer pricing policy.

Another issue with before-and-after comparisons is the likely difficulty of valuing the basket of functions, assets and risks that were lost by the restructured entity, keeping in mind that it is not always the case that these functions, assets and risks are transferred to another party.

That being said, in business restructurings, before-and-after comparisons could play a role in understanding the restructuring itself and could be part of a before-and-after comparability (including functional) analysis to understand the changes that accounted for the changes in the allocation of profit / loss amongst the parties. In effect, information on the arrangements that existed prior to the restructuring and on the conditions of the restructuring itself could be essential to understand the context in which the post-restructuring arrangements were put in place and to assess whether such arrangements are arm's length. It can also shed light on the options realistically available to the restructured entity.

A comparability (including functional) analysis of the business before and after the restructuring may reveal that while some functions, assets and risks were transferred, other functions may still be carried out by the "stripped" entity under contract for the foreign associated enterprise. A careful review of the respective roles of the foreign associated enterprise and of the "stripped" entity will determine what the most appropriate transfer pricing method to the circumstances of the case is, for instance whether or not it is appropriate to allocate the whole residual profit to the foreign associated enterprise in view of the actual risks and intangibles of the "stripped" entity and of the foreign associated enterprise.

There will also be cases where before-and-after comparisons can be made because the transactions prior to the restructuring were not controlled, for instance where the restructuring follows an acquisition, and where adjustments can reliably be made to account for the differences between the pre-restructuring uncontrolled transactions and the post-restructuring controlled transactions.

## 5) Location savings

Location savings can be derived by an MNE group that relocates some of its activities to a place where costs (such as labour costs, real estate costs, etc.) are lower than in the location where the activities were initially performed, account being taken of the possible costs involved in the relocation (such as termination costs for the existing operation, possibly higher infrastructure costs in the new location, possibly higher transportation costs if the new operation is more distant from the market, training costs of local employees, etc.).

Where significant location savings are derived further to a business restructuring, the question arises of whether and if so how the location savings should be shared among the parties. The response should obviously depend on what independent parties would have agreed in similar circumstances. The conditions that would be agreed between independent parties would normally depend on the functions, assets and risks of each party and on their respective bargaining powers.

Take the example of an enterprise that designs, manufactures and sells brand name clothes. Assume that the manufacturing process is basic and that the brand name is famous and represents a highly valuable intangible. Assume that the enterprise is established in Country A where the labour costs are high and that it decides to close down its manufacturing activities in Country A and to relocate them in an affiliate company in Country B where labour costs are significantly lower. The enterprise in Country A retains the rights on the brand name and continues designing the clothes. Further to this restructuring, the clothes will be manufactured by the affiliate in Country B under a contract manufacturing arrangement. The arrangement does not involve the use of any significant intangible owned by or licensed to the affiliate or the assumption of any significant risks by the affiliate in Country B. Once manufactured by the affiliate in Country B, the clothes will be sold to the enterprise in Country A which will on-sell them to third party customers. Assume that this restructuring makes it possible for the group formed by the enterprise in Country A and its affiliate in Country B to derive significant location savings. The question arises whether the location savings should be attributed to the enterprise in Country A, or its affiliate in Country B, or both (and if so in what proportions).

In such an example, given that the relocated activity is a highly competitive one, it is likely that the enterprise in Country A has the option realistically available to it to use either the affiliate in Country B or a third party manufacturer. As a consequence, it should be possible to find comparables data to determine the conditions in which a third party would be willing at arm's length to manufacture the clothes for the enterprise. In such a situation, a contract manufacturer at arm's length would generally be attributed very little, if any, part of the location savings. Doing otherwise would put the associated manufacturer in a situation different from the situation of an independent manufacturer, and would be contrary to the arm's length principle.

As another example, assume now that an enterprise in Country X provides highly specialised engineering services to independent clients. The enterprise is very well known for its high quality standard. It charges a fee to its independent clients based on a fixed hourly rate that compares with the hourly rate charged by competitors for similar services in the same market. Suppose that the wages for qualified engineers in Country X are high. The enterprise subsequently opens a subsidiary in Country Y where it hires equally qualified engineers for substantially lower wages, and subcontracts a large part of its engineering work to its subsidiary in Country Y, thus deriving significant location savings for the group formed by the enterprise and its subsidiary. Clients continue to deal directly with the enterprise in Country X and are not necessarily aware of the sub-contracting arrangement. For some period of time, the well known enterprise in Country X can continue to charge its services at the original hourly rate despite the significantly reduced engineer costs. After a certain period of time, however, it is forced due to competitive pressures to decrease its hourly rate and pass on part of the location savings to its clients. In this case also, the question arises of which party(ies) within the MNE group should be attributed the location savings at arm's length: the subsidiary in Country Y, the enterprise in Country X, or both (and if so in what proportions).

In this example, it might be that there is a high demand for the type of engineering services in question and the subsidiary in Country Y is the only one able to provide them with the required quality standard, so that the enterprise in Country X does not have many other options available to it than to use this service provider. It might be that the subsidiary in Country Y has developed a valuable intangible corresponding to its technical know-how. Such an intangible would need to be taken into account in the determination of the arm's length remuneration for the sub-contracted services. In appropriate circumstances (e.g. if there are significant unique contributions such as intangibles used by both the enterprise in Country X and its subsidiary in Country Y), the use of a transactional profit split method may be considered.

#### **6) Example: implementation of a central purchasing function**

This section illustrates the application of the arm's length principle in the case of the implementation of a central purchasing function. It reflects the central importance of comparability analyses and in particular of the functional analysis in order to understand the role played by each of the parties in the creation of synergies, costs savings, or other integration effects. The list below is not intended to cover all the possible situations but only the most frequent ones. Which transfer pricing method is the most appropriate will depend on the facts and circumstances of the case. In particular, a determination of which party(ies) should be allocated the cost savings or inefficiencies created by the centralisation of the purchasing function will depend on the particular circumstances of each case.

Assume an MNE group puts in place a central purchasing entity that will negotiate with third party suppliers the purchases of raw materials used by all the manufacturing plants of the group in their manufacturing processes. Depending in particular on the respective functional analyses of the manufacturing plants and of the central purchasing entity and on the contractual terms they have agreed upon, a variety of remuneration schemes and transfer pricing methods could be considered.

First, there will be cases where the CUP method will be applicable. Assume the central purchasing entity purchases the raw materials from third party suppliers and sells them to the manufacturing plants. The CUP method might be applicable if the raw materials are traded on a commodity market (see paragraph 2.18). It may also be the case that the price that was paid by the manufacturing plants before the interposition of the central purchasing entity or the price paid by independent parties for comparable raw materials may, subject to a review of the facts and circumstances and of the effects of the controlled and uncontrolled transactions taking place at different times, be used as a comparable uncontrolled price to determine the price at which the manufacturing plants should acquire the raw materials from the central purchasing entity. However, such a CUP, if unadjusted, may well mean that all the costs savings would be attributed to the central purchasing entity. A determination of whether or not this would be an arm's length condition has to be made on a case by case basis. Should it be determined that in the circumstances of the case, a portion of the cost savings should be attributed to the manufacturing entities, then the question would arise whether the CUP should and could be adjusted accordingly.

Where the CUP method cannot be used, e.g. because the price of the raw materials fluctuates and the price paid by the manufacturing entities before the setting up of the central purchasing entity cannot serve as a reference, the cost plus method might be considered. For instance, the central purchasing entity might purchase the raw materials from third party suppliers and re-sell them to the manufacturing plants at cost plus, i.e. the new purchase price of the raw material by the central purchasing entity plus an arm's length mark-up. In such a case, the mark-up rate attributed to the central purchasing entity should be comparable to the mark-up rate earned in comparable uncontrolled trading activities.

In some cases, the central purchasing entity acts as an agent either for the suppliers or for the purchasers (or both) and is remunerated by a commission fee paid either by the suppliers or by the purchasers (or both). This might be the case where the central purchasing entity negotiates with the third party suppliers but does not take title to the inventories, i.e. the manufacturing plants continue to acquire the raw materials directly from the suppliers but at a discounted price obtained thanks to the activity of the central purchasing entity and to the participation of the group of manufacturing plants

in the arrangement. The commission fee might be proportional to the supplies (especially if paid by the supplier) or to the discounts obtained (especially if paid by the manufacturing plants). It should be comparable to the commission fee that would be charged by independent parties for comparable agency functions in similar circumstances.

It may happen that what would be *prima facie* regarded as an arm's length mark-up on costs or commission fee from the perspective of the central purchasing entity in effect leads to determining purchase prices for the manufacturing entities that are higher than the prices they could obtain by themselves. If the incremental costs that are created for the manufacturers are material (e.g. they materially affect, on a recurrent basis, the basket of products channelled through the central purchasing entity), the question arises whether independent manufacturers would have agreed to pay such higher prices and what the economic rationale would be, or whether at arm's length the central purchasing entity should bear part or all of the inefficiencies through a reduction of its sales prices to the manufacturers. The response will depend on the facts and circumstances of the case. Key to the analysis will be the determination of the benefits that could reasonably be expected by the parties (manufacturing entities and central purchasing entity) from the implementation of the central purchasing function, and of the options realistically available to them, including in appropriate cases the option not to participate in the central purchasing in case the expected benefits were not as attractive as under other options. Where benefits could reasonably have been expected by the parties, it will be key to analyse the reasons for the central purchasing entity's apparent inefficiency, the contractual terms under which the central purchasing entity operates and the functional analysis of the manufacturers and of the central purchasing entity, in particular their respective roles and responsibilities in the decisions that led to the inefficiencies. This analysis should make it possible to determine what party(ies) should be allocated the inefficiency costs and to what extent. Where this analysis indicates that inefficiencies should be allocated to the central purchasing entity, one way of doing so would be to price the sale transactions to the manufacturing entities by reference to CUP *i.e.* based on prices that the manufacturing entities could obtain on the free market for comparable supplies in comparable circumstances. No inference should be drawn however that any inefficiencies should be allocated by default to the central purchasing function, or that the positive effects of synergies should always be shared amongst the members of the group.

Finally, there might be some cases where the costs savings (or costs) generated by the centralisation of the purchasing function would be shared amongst the central purchasing entity and the manufacturing plants through a form of profit split.

## **7) Determining whether arrangements would have been adopted by independent enterprises**

The second circumstance explicitly refers to the situation where the arrangements adopted by the associated enterprises "differ from those which would have been adopted by independent enterprises behaving in a commercially rational manner..." Tax administrations should not ordinarily interfere with the business decisions of a taxpayer as to how to structure its business arrangements. A determination that a controlled transaction is not commercially rational must therefore be made with great caution, and only in exceptional circumstances lead to the non-recognition of the associated enterprise arrangements.

Where reliable data show that comparable uncontrolled transactions exist, it cannot be argued that such transactions between associated enterprises would lack commercial rationality. The existence of comparables data evidencing arm's length pricing for an associated enterprise arrangement demonstrates that it is commercially rational for independent enterprises in comparable circumstances. On the other hand, however, the mere fact that an associated enterprise arrangement is not seen between independent enterprises does not in itself mean that it is not arm's length nor commercially rational.

Business restructurings often lead MNE groups to implement global business models that are hardly if ever found between independent enterprises, taking advantage of the very fact that they are MNE groups and that they can work in an integrated fashion. For instance, MNE groups may implement



global supply chains or centralised functions that are not found between independent enterprises. It is therefore often difficult to assess whether such business models are of the kind that independent enterprises behaving in a commercially rational manner would have implemented. This lack of comparables does not mean of course that the implementation of such global business models should automatically be regarded as not commercially rational.

What is being tested is whether the outcome (the arrangement adopted) accords with what would result from normal commercial behaviour of independent enterprises; it is not a behaviour test in the sense of requiring the associated enterprises to actually behave as would independent enterprises in negotiating and agreeing to the terms of the arrangement. Thus, whether the associated enterprises actually engaged in real bargaining or simply acted in the best interests of the MNE group as a whole in agreeing to a restructuring does not determine whether the arrangement would have been adopted by independent enterprises behaving in a commercially rational manner or whether arm's length pricing has been reached.

The application of the arm's length principle is based on the notion that independent enterprises will not enter into a transaction if they see an alternative that is clearly more attractive. A consideration of the options realistically available can be relevant to determining arm's length pricing for an arrangement. It can also be relevant to the question of whether arrangements adopted by associated enterprises differ from those which would have been adopted by independent enterprises behaving in a commercially rational manner. There may be exceptional cases in which arm's length pricing cannot reliably be determined for the arrangement actually adopted, and it is concluded that the arrangement would not have been adopted in comparable circumstances by independent enterprises behaving in a commercially rational manner.

An independent enterprise would not enter into a restructuring transaction if it sees an alternative option that is realistically available and clearly more attractive, including the option not to enter into the restructuring. In evaluating whether a party would at arm's length have had other options realistically available to it that were clearly more attractive, due regard should be given to all the relevant conditions of the restructuring, to the rights and other assets of the parties, to any compensation or indemnification for the restructuring itself and to the remuneration for the post-restructuring arrangements (as discussed in Parts II and III of this chapter) as well as to the commercial circumstances arising from participation in an MNE group.

In assessing the commercial rationality of a restructuring, the question may arise whether to look at one transaction in isolation or whether to examine it in a broader context, taking account of other transactions that are economically inter-related. It will generally be appropriate to look at the commercial rationality of a restructuring as a whole. For instance, where examining a sale of an intangible that is part of a broader restructuring involving changes to the arrangements relating to the development and use of the intangible, then the commercial rationality of the intangible sale should not be examined in isolation of these changes. On the other hand, where a restructuring involves changes to more than one element or aspect of a business that are not economically inter-related, the commercial rationality of particular changes may need to be separately considered. For example, a restructuring may involve centralising a group's purchasing function and centralising the ownership of valuable intangible property unrelated to the purchasing function. In such a case, the commercial rationality of centralising the purchasing function and of centralising the ownership of valuable intangible property may need to be evaluated separately from one another.

There can be group-level business reasons for an MNE group to restructure. However, it is worth re-emphasising that the arm's length principle treats the members of an MNE group as separate entities rather than as inseparable parts of a single unified business. As a consequence, it is not sufficient from a transfer pricing perspective that a restructuring arrangement makes commercial sense for the group as a whole: the arrangement must be arm's length at the level of each individual taxpayer, taking account of its rights and other assets, expected benefits from the arrangement (*i.e.* consideration of the post-restructuring arrangement plus any compensation payments for the restructuring itself), and realistically available options.



Where a restructuring is commercially rational for the MNE group as a whole, it is expected that an appropriate transfer price (that is, compensation for the post-restructuring arrangement plus any compensation payments for the restructuring itself) would generally be available to make it arm's length for each individual group member participating in it.

### **8) Determining whether a transaction or arrangement has an arm's length pricing solution**

Under the second circumstance, a second cumulative criterion is that "the actual structure practically impedes the tax administration from determining an appropriate transfer price." If an appropriate transfer price (*i.e.* an arm's length price that takes into account the comparability – including functional – analysis of both parties to the transaction or arrangement) can be arrived at in the circumstances of the case, irrespective of the fact that the transaction or arrangement may not be found between independent enterprises and that the tax administration might have doubts as to the commercial rationality of the taxpayer entering into the transaction or arrangement, the transaction or arrangement would not be disregarded under the second circumstance. Otherwise, the tax administration may decide that this is a case for not recognising the transaction or arrangement under the second circumstance.

### **9) Relevance of tax purpose**

The fact that a business restructuring arrangement is motivated by a purpose of obtaining tax benefits does not of itself warrant a conclusion that it is a non-arm's length arrangement. The presence of a tax motive or purpose does not of itself justify non-recognition of the parties' characterisation or structuring of the arrangement.

### **10) Consequences of non-recognition**

Where the economic substance of a transaction differs from its form, the tax administration may disregard the parties' characterisation of the transaction and re-characterise it in accordance with its substance.

With respect to the second circumstance, an example of non-recognition of a sale and note that while it may be proper to respect the transaction as a transfer of commercial property, it would nevertheless be appropriate for a tax administration to conform the terms of that transfer in their entirety (and not simply by reference to pricing) to those that might reasonably have been expected had the transfer of property been the subject of a transaction involving independent enterprises. In such a case, the tax administration would seek to adjust the conditions of the agreement in a commercially rational manner.



# Study Note - 3

## STRATEGIC PERFORMANCE EVALUATION AND MANAGEMENT TOOLS



### This Study Note includes

- 3.1 Benchmarking
- 3.2 Business Process Re-engineering
- 3.3 Value Chain Analysis
- 3.4 Activity, Porter's Value Chain Management Evaluation and Performance Analysis of Strategic Decisions Executed through
  - (i) Target Costing - Profit Planning & Cost Management
  - (ii) Activity Based Management - Understand Cost to Improve Value
  - (iii) Life Cycle Costing
- 3.5 Lean Management & Process Mapping

### 3.1 BENCHMARKING

Benchmarking is the continuous process of measuring products, services or activities against the best levels of performance that may be found either inside or outside the organization. It is a process of comparing a firm's activities with best practices. The process involves establishment of benchmarks (targets or comparators), through use of which the levels of performance of the company is sought to be improved. Benchmarking is a tool for continuous improvement because after identifying a best practice performance, it becomes a target to beat.

There may be two types of benchmarking: *intra-group* and *inter-industry*. In the former case, groups of companies in the same industry agree that similar units within the co-operating companies will pool data on their processes. The processes are benchmarked against each other and improvement task forces are established to identify and report "best practice" to all members of the group so that each participating company can achieve it and beat it. In inter-industry benchmarking, non-competing firms with similar processes are identified and asked to participate in benchmarking exercise. The objective is to benefit from the experience of the other, and establish best practice in their common business processes. Benchmarking can be applied in any business process or activity for continuous improvement, e.g., quality, cost, productivity, process, customer service, and so on.

#### Definition:

The International Benchmarking Clearinghouse ("IBC") of American Productivity and Quality Center ("APQC") has given the following definition of Benchmarking.

"A systematic and continuous measurement process; a process of continuously comparing and measuring an organization's business processes against business leaders anywhere in the world, to gain information that will help the organization take action to improve its performance".

Benchmark: " A measure, "best - in - class" achievement; a reference or measurement standard for comparison, a performance level recognized as the standard of excellence for a specific business practice".

Rank Xerox, which pioneered this concept, defines Benchmarking as "A continuous systematic process of evaluating companies recognized as industry leaders, to determine business and work processes that represent "best practice and established rational performance goals".

At IBM Benchmarking is “the continuous process of enlisting the best practice in the world for the process goals and objectives leading to world class levels of achievement.

**3.1.1 The Steps in Benchmarking are as follows:**

This could be depicted as under:

Rank Xerox has given the following ten steps for Benchmarking:

<b>Planning</b>	1.	Identify benchmark outputs
	2.	Identify best competitors
	3.	Determine data collection method.
	4.	Determine current competitive “gap”
	5.	Project future performance level.
<b>Integration</b>	6	Establish functional goals; communication of data / acceptance of Analysis.
	7.	Develop functional action plan.
<b>Action</b>	8.	Implement specific actions
	9.	Monitor results / Report Progress
	10.	Recalibrate benchmarks

**3.1.2 Types of Benchmarking:**

Let us explain in detail below:

**A. Product Benchmarking (Reverse Engineering)**

This is an age old practice of product oriented reverse engineering. Every organization buys its rival's products and tears them down to find out the features and performances etc. compared with its products. This could be the starting point for improvement. When Ford Motor Company redesigned the Taurus in 1992, it benchmarked 209 features on the car against 7 competitors. The company then worked to match / excel the higher standard set by any of its rival, in each of these features with its own product.

Japanese seemed to have excelled at this practice but to their credit it must be said that they just do not imitate, but ingeniously innovate.

**B. Competitive Benchmarking**

“A Measure of organizational performance compared against competing organization; studies the target specific product designs, process capabilities or administrative methods used by a company's direct competitors”.

Competitive Benchmarking moved beyond product oriented comparisons to include comparisons of process with those of competitors. In this benchmarking, the process studied may include marketing, finance, human resource, R & D etc. A typical example would be the classical study the Rank Xerox performed with those of Canon and other photo copier manufacturers when it faced heightened competition from US and Japanese companies. By benchmarking Rank Xerox achieved significant performance improvements as given below:

- ❖ Unit manufacturing cost reduced to half; comparable to 1980 product costs
- ❖ Machine defects have improved by over 90%



- ❖ Incoming parts acceptance has improved to 99.5%
- ❖ Inventory methods of supply reduced by at least two thirds.
- ❖ Engineering drawings per person year more than doubled
- ❖ Marketing Productivity improved by one third.
- ❖ Service labour cost reduced by 30%
- ❖ Distribution productivity increased from 5% to 10%

Management Accountants are familiar with the technique of inter firm comparison of financial performance of companies through ratios to draw meaningful inferences. For instance Hindalco's power cost is lowest in the world, due to the captive power plant set up by them long back. Other aluminum producers while endeavoring to move closer to this standard must improve in other areas to have competitive parity.

### C. Process Benchmarking

"The activity of measuring discrete performance and functionality against organizations through performance in excellent analogous business processes".

To gain leadership position it is essential to look at a paradigm-shifting jump to a new way of managing a process; for this you may have to go beyond your industry and look at the "best-in-breed" to bring about a fundamental change and not just an incremental improvement.

When Airlines wanted to improve their turn around times they compared the performance with the Pit Crew of Formula I races since it is well known that they are best in class in that operation. Hospitals in U.S. compare their patient management systems with the guest management practice in hotels. American Express credit card division compares its document handling process with that of a courier company. Citibank (India) instituted a benchmarking exercise in respect of HR practices and public relations with those of Hindustan Lever Ltd. Cadbury India benchmarks its distribution and logistics function not with Nestle but with Hindustan Lever Ltd. For supply chain management the best practice would be that of Mumbai Dabbawallas, which has now won universal acclaim.

#### Certain similar types of benchmarking are noted below:

- D. Functional Benchmarking** - "An application of process benchmarking that compares a particular business function at two or more organizations.
- E. Generic Benchmarking** - "An application of functional process benchmarking that compares a particular business function at two or more organizations, selected without regard to their industry.
- F. Internal Benchmarking**

"An application of process benchmarking performed, within an organization by comparing the performance of similar business units or business processes".

Hewlett Packard through an extensive internal benchmarking exercise on the Best Scheduling Practice amongst its several product groups was able to cut its "time-to-market" by half. For a company like HP introduction of new products in time was a crucial performance metric. McKinsey study has shown that hi-tech products that were on budget, but six months behind schedule, sacrificed 33% of their potential profit over the first five years in the market. It might interest Management Accountants to know that the same study showed that on time project that were 50% over budget lost only 4% of the profits over the same period.

With 35 companies spanning seven different businesses, RPG Group is benchmarking the process and standards in each company against others in the group. Named the knowledge improvement process (KIP), benchmarking is a formal exercise to spread the best practice of one company horizontally across the group. Every company in the Group has been benchmarking itself against the others on

12 specific parameters; purchase management, value engineering, inventory management, energy saving, insurance optimization, demand forecasting, receivables management, make or buy decision market research, pricing strategy, logistics management, and financing options.

### **G. Strategic Benchmarking**

“The application of process benchmarking at the level of business strategy; a systematic process for evolving alternatives, implementing strategies, and improving performance by understanding and adapting successful strategy from external partners who participated in an on-going business alliance”.

It will be seen that strategic benchmarking differs from operational benchmarking in its scope; it helps to develop a vision of the changed organizations; it will develop core competencies that will help sustaining competitive advantage; targeting a specific shift in strategy such as entering new markets or develop new products, developing a new line of business or making an acquisition and creating an organization that is more capable of learning how to respond in an uncertain future because it has increased its acceptance of change.

In mid 1980's When Jack Welch of General Electric wanted to position his company for the coming decade, he asked his Strategic Planning Group to study how successful companies positioned themselves for continuous improvement. The results of the study provided operating definitions of a company that is World Class.

- It is one which knows its process better than its competitors knows their processes.
- Knows its industry competitors better than its competitors.
- Knows its customers better than its competitors.
- Responds more rapidly to customer behavior than competitors do.
- Competes for market share on a customer by customer basis.

The lessons learnt and successfully applied by G.E. resulted in its pole vaulting itself as the premier world organization.

GE applied benchmarking in the area of strategy which clearly shows the contribution of macro level benchmarking for developing long range plans. When Hindustan Lever Ltd., planned to penetrate into rural areas, it benchmarked its rural market against a beedi manufacturer.

### **H. Global Benchmarking:**

This is defined as “the extension of strategic benchmarking to include benchmarking partners on a global scale”. A classic example of global benchmarking is given by Michael Hammer in his book “Re-engineering the corporation”. He cites the example of Ford Company of US, which benchmarked its accounts payable function with that of Mazda in Japan and found to its astonishment that the entire function was managed by 5 persons as against 500 in Ford.

When Larsen & Toubro Ltd., the engineering and construction powerhouse wanted to enter the world market for projects, it deemed it fit to benchmark its project management skills with global rivals, Bechtel and Fluor Daniel Corporation of US, assisted by McKinsey Co., Draughtsman were benchmarked for their CAD/CAM proficiency as well as their ability to handle bill of materials. Once gaps were identified, L & T used a combination of training and external recruitment to close them.

WAITRO (World Association of Industrial and Technological Research Organization) in the year 1994 under took a global benchmarking exercise covering R & D organizations from Asian, African, European and American subcontinents. The exercise focused on organization processes and practices. The base idea was to deconstruct an organization in terms of its various activities, which were termed as processes and from different R&D organizations information was collected on how these activities were carried out, which were termed as practices. As a R & D organization is a knowledge generating organization, any practice that facilitates this objective was considered a good practice and the



ones which were deviating from the basic objective were considered as bad practice. In this way organizational processes and practices were analyzed and a set of practices for each of the processes were suggested as good / bad practices.

### **3.1.3 What to Benchmark?**

Any process or activity, strategic or operational can be benchmarked. Its scope encompasses the entire gaunt of management. Xerox for instance has identified 67 business processes to a major business unit involved with sales, service and business operation under 10 broad groups. Xerox has identified 76 processes at a higher company-wide or enterprise level to cover the full spectrum of operations from product inception, design, engineering, manufacturing as well as customer delivery under 14 broad sub groups.

The choice of what to benchmark must naturally be guided by the critical success factor relevant to the business, that can be leveraged most for business improvement. Prioritization is the vital first step in the whole exercise.

### **3.1.4 Sources for collecting information on Benchmarking**

- (i) Management consulting organization have set up data bases as mentioned below :
  - a. A.T. Kearney's Manufacturing Centre for Excellences.
  - b. Price Water Houses' Benchmarks Alliance
  - c. Arthur Andersons Global Best Practices Knowledge Base.
- (ii) American Productivity and Quality Centre's, International Benchmarking Clearing house.
- (iii) Industry Associations
- (iv) Govt. Publications
- (v) Business Magazines
- (v) Market survey findings etc.

### **3.1.5 Does Benchmarking tantamount to Industrial Espionage**

Benchmarking, it must be categorically stated is by no means synonymous with industrial espionage. The initiation of benchmarking study pre-supposes voluntary and willing co-operation between the benchmarking parties to open up their books on a reciprocal basis. It is implicitly understood that no information of proprietary or confidential nature will be parted and the sharing of information and experience is in total conformity with ethical conduct. In short, the benchmarking exercise should result in a win - win situation.

The APQC - IBC has drawn up a benchmarking code of conduct which sets forth the protocol of benchmarking - a set of conventions prescribing correct etiquette and procedures to be used in conducting benchmarking studies.

### **3.1.6 Benchtrending**

While the benefits of benchmarking are quite impressive, it results in the benchmarking partner to be forever in a catch up situation. The better partner will not stand still but will be booking continuously for ways to improve his own performance. To leapfrog it becomes imperative for an organization to continuously do a P.E.S.T Scan - monitor the developments in the political, economic social and technological fronts and identify future gaps that may be created by significant market changes, customer preferences, innovation, threats of new entrants and other environmental variables critical to the long term success of the firm. Such trend studies are known as "Benchtrending" which is similar to benchmarking, but with a structural dimension.



There are two types of bench trending- Strategic Bench Trending is used to set direction for a business unit and Operations or Process Bench trending which is used to identify technological trends and steps initiated to bridge the gaps in current performance levels.

### **3.1.7 The Steps in strategies bench trending are as follows:**

- (i) Firstly the market is defined by determining its size, customer preferences, competitors and relative business position of the company within the market.
- (ii) The industry direction, technology shifts, geopolitical changes, customer changes and potential threats from outside sources are assessed.
- (iii) The strongest current and potential competitors are then determined by evaluating the trends in industry.
- (iv) Data on performance of competitors is gathered and the current and future performance of the unit is compared with that of its competitor.
- (v) A performance baseline for the business units is then established and the relative performance of current and projected competition is estimated.
- (vi) A set of initiatives which form the basis of an improvement plan are identified to maintain strengths while reducing projected gaps.

For instance Indian Auto companies must plan to design their products to meet Euro III standards which will become the order of the day. Even a company like Microsoft was late in spotting the emergence of the Internet, though it woke up in time to change gear and adapt to the requirements of the new technology.

Pharma companies in US must take note of the changing demographic profile to develop medicines to meet the needs of ageing population.

To sum up, to effectively compete in the global market, companies should be adept at the techniques if not only benchmarking but more importantly, bench trending too.

### **3.1.8 Areas of Benchmarking in Cement Industry**

The most critical areas to be considered for benchmarking in cement industry are indicated below:

#### **(i) Optimum Utilization of Installed Capacity of Plant and Machinery**

The machinery and equipment installed in various sections of the plant are required to be stopped at periodical intervals for inspection, repairs and maintenance purposes. During such stoppages, there is loss of production besides the expenditure on account of repairs and maintenance work. Additionally, the unit incurs expenses for payment of wages to employees attached to such departments though there is no work for them during the period the machines are down for repairs.

As per generally accepted norms, the annual installed capacity of a Cement Plant is determined on the basis of the Kiln running for 330 days. Thus a Kiln with a rated output of 10,000 tonnes clinker per day will have an annual capacity of 3.30 million tonnes of clinker. Downtime of 35 days in a year is considered normal for brick lining and repairs, etc. If any Cement Plant is able to reduce the down time of kiln even by one day, it can produce an additional 10,000 tonnes of clinker, which is equivalent to 13000 tonnes of Portland Pozzolana Cement assuming the usage of fly ash at 25% and gypsum at 5%. There are cement plants, which run even for 345 days in a year, thus reducing the down time of kiln to 20 days only. Such plants have thus a distinct advantage over the other plants because by increasing the volume of cement production, they are able to reduce the overall cost of production and improve their profitability. By benchmarking the plant maintenance practices of such efficient Units, the other cement plants can also improve their volume of production leading to higher profitability.



The pyro-processing section including the kiln is considered the most critical section in a cement plant because the loss of clinker production is a loss for ever. It is customary to have some excess capacity for other machinery and equipment right from mining machinery to crusher, Raw mills, Coal Mills, etc. so that kiln operation is not hampered in any way and clinker production is not adversely affected. Similarly, some excess capacity is provided in cement mills and packing plant.

Information can be gathered without much difficulty about the running hours and the output per hour of the mills of various cement plants. After obtaining the data in respect of the most efficient plant, efforts should be made to ascertain the operating and maintenance practices followed by such plant and the same practices should be adopted to improve the plant performance of the enterprise. Such benchmarking practices should be followed on a regular basis as the competing units will continue to improve their operations.

The frequency of intervals at which the machines are required to be stopped for repairs and maintenance and the time required to carry out the repairs and maintenance work are, therefore, major factors affecting the production and profitability of the plant. It would, therefore, be advisable for cement plants to carry out benchmarking studies of the practices followed by the most efficient plant in the following important matters:

- (a) Number of days the critical sections of the plant run continuously without any stoppages.
- (b) Measures adopted to avoid break-downs or frequent stoppages for repairs and maintenance.
- (c) Quality of materials and parts used in the critical areas of the machines to ensure running for longer period, e.g., use of basic bricks in kilns.
- (d) Inspection and maintenance practices followed by the target plant.
- (e) Organizational set up for completing repairs and maintenance work satisfactorily and expeditiously.

## **(ii) Maximizing output from machinery**

Having ensured the optimum availability of the plant and machinery, a cement unit must critically look at the rates of output per day/hour for each production department. The output from the machines depends upon various factors, e.g.,

- (a) The required grade and quality of the product.
- (b) Proportionate usage of various materials forming part of the product, e.g., usage of fly ash in Portland Pozzolana Cement and blast furnace granulated slag in Portland Slag Cement.
- (c) Uninterrupted power supply.
- (d) Proper and continuous feed of the input materials.
- (e) Prompt measures to prevent choking of machines.
- (f) Rigorous quality inspection schedule.

Cement plants should necessarily devote full attention to the rate of output per day/hour in each production department and benchmark the same with the most efficient plant having similar machinery and equipment. Production is invariably the most limiting factor in cement plants as the entire cement production is sold out without much effort. Any increase in volume of production in a cement plant leads to improvement in profitability.

## **(iii) Improving productivity of manpower**

In any area of business activity, the optimum utilization of manpower is of paramount importance. In cement industry, the wage structure of workmen is governed by Wage Board awards and the unskilled/semi-skilled workmen are amongst the highest paid workers in the country. The old cement plants have a large labour force due to historical reasons and to that extent, they are at

a disadvantage as compared to large-sized modern plants. However, by a rational deployment of the workmen and by imparting proper training to them, their productivity can be improved. The workers can be encouraged to acquire multiple skills so that they are deployed for various functions as required.

It would be highly useful to carry out benchmarking exercises in this vital area by studying the practices followed by the most efficient plant operating under similar conditions so that such practices may be adopted by the cement unit.

**(iv) Enforcing safety regulations**

In a cement plant, heavy machinery and equipment are installed where material is processed at very high temperatures and with moving parts, e.g., conveyor belts and large capacity fans, etc. The persons attending to such equipment have to be protected from accidents. There are several statutory provisions relating to safety of workmen, which are required to be complied with. Cases are not uncommon where serious accidents, including fatal accidents, take place in cement plants due to non-observance of safety precautions. Such accidents not only make the plant management liable for payment of heavy compensation and even prosecution but also lead to stoppage of work in the plant causing heavy loss of production. It would, therefore, be highly useful for cement plants to adopt benchmarking practices in matters relating to safety of employees by studying the safety systems followed by the plant having the best safety record.

**(v) Controlling and reducing costs**

The management of a company has little or no control over the prices of materials and stores/spare parts purchased by them for various manufacturing operations. The wages of workmen are also governed by Wage Board awards and variable dearness allowance is linked with cost of living index. The various taxes levied by local authorities and State and Central Governments are also beyond the control of the management. However, a company has to fix the prices of its products in line with the market conditions and the prices of the competing products. Therefore, there is an imperative necessity of introduction of cost control measures in all activities of the organization so as to offset to the extent possible, the adverse impact on its profitability on account of rise in prices of inputs. Inefficiencies and wastes must be eliminated and all out efforts should be made to prune down the non-productive expenditure. The major items of expenditure could be benchmarked with the most efficient company and systematic efforts should be made to reduce the expenditure to the desired levels.

**Items of Costs for Benchmarking**

The following items of costs are incurred for manufacturing and selling cement. All these items of cost need focused attention of the management because in a competitive scenario, an inefficient plant will not have the liberty of fixing a price of its product, which will not only cover its cost of production but also allow it to make profit. Benchmarking with the most cost efficient plant with respect to the various cost components will enable the weaker units to improve their profitability and sail through the choppy market situations comfortably.

1. Limestone
2. Other raw materials, e.g., laterite, bauxite, iron-ore, etc.
3. Gypsum
4. Fly Ash for manufacturing Portland Pozzolona Cement
5. Blast Furnace Granulated Slag for manufacturing Portland Slag Cement
6. Kiln Fuel, e.g., Coal, Pet coke, Lignite, Furnace Oil, Natural Gas, etc.
7. Electrical energy



8. Consumable stores and spare parts
9. Packing materials
10. Manpower
11. Rail/Road/River/Ocean freight for movement of cement from the Cement Plant to customers.
12. Works Overhead, Administrative Overhead and Selling and Distribution Overhead excluding freight.

### **Limestone**

Cement Units invariably have captive limestone mines and raise limestone as per their requirements. The following areas of operations may be considered for benchmarking :

- (i) Powder factor for explosives used
- (ii) Cost per tonne of overburden removed
- (iii) Output per man shift
- (iv) Operating cost per running hour of Shovels, Rock breakers, Drilling machines, Dozers, Dumpers, Tractors, etc. The idle hours per day and the loss on that account for each machine may be recorded for comparison with the most efficient producer and appropriate action be taken to reduce such losses.

The nature of limestone deposits and extent of overburden to be removed differ from quarry to quarry and these factors may be taken into account while benchmarking the operations.

Limestone accounts for a large chunk of the cost of production of cement and, therefore, the importance of benchmarking the various operations relating to mining and transport of this material to the crusher and the crushed material to the factory cannot be over emphasized. The mining operations are largely mechanized but still the manpower cost associated with various operations is quite significant. Therefore, the levels of efficiency of the persons engaged for various processes need to be benchmarked with the most efficient producer to keep the cost of limestone mined and transported in line with the costs of the competitors.

The costs of consumable stores and spare parts for mining operations and maintenance of mining machinery and equipment and also the transport fleet, are required to be benchmarked with the most efficient cement producer. The most appropriate and cost effective explosives should be selected for blasting operations and the usage of explosives in terms of Kilograms per tonne of rock blasted should be benchmarked with the best cement plant. Similarly, the H.S. Diesel used in Heavy Earth moving equipment like dumpers, shovels, dozers, pay-loaders, etc. for transporting overburden as also limestone from the quarry pithead to the required places should be benchmarked with the most efficient plant to keep the costs comparable with the competitors. The utilization hours for each machine and transport vehicle need to be benchmarked so as to improve the productivity levels and reduce idle time of the machinery and vehicles. If the machinery is down, the workers operating the machinery will have no work to do and the idle hours of workers will increase. Wherever it is possible, the data about all aspects of mining operations of the most efficient cement plant may be obtained and benchmarking exercises may be carried out in order to achieve the same standards of efficiency.

### **Other Raw Materials**

Laterite, bauxite, Iron-ore, Red Okre, etc. are used as correcting materials. The sources of supply and the quality of material mainly determine the cost of these items and benchmarking is to be attempted accordingly.

### **Gypsum**

Mineral and Chemical Gypsum are used for regulating the setting time of cement. The usage of gypsum

is determined by each cement Unit on the basis of the chemical contents of clinker and quality of gypsum. The comparative costs of clinker and gypsum are also considered while determining the usage factor of gypsum. Mineral gypsum is available only at a few places in India and the transportation cost is a major expense for this material, which needs to be controlled through benchmarking exercises.

### **Fly Ash**

With the setting up of several coal-based Power Plants, large quantities of Fly Ash is available in the country. The production of fly-ash based Pozzolona Cement is increasing rapidly. The source of supply determines the cost of fly ash as freight is the main element of cost. B.I.S. allows the usage of fly ash to the extent of 35% in Portland Pozzolana Cement. However, the usage of fly ash depends upon the quality of clinker and the required quality of the end product, viz., cement.

In a highly competitive market, benchmarking for procurement, handling and processing of fly ash may be taken up to match the quality parameters and cost of the end product with the most efficient producer.

### **Blast Furnace Granulated Slag**

This is a waste product of Steel Mills but it is purchased by cement producers to manufacture Portland Slag Cement by inter-grinding with clinker or by grinding separately and mixing with Ordinary Portland Cement. The cost of Blast Furnace Slag is generally much lower than that of clinker and, therefore, higher usage of slag vis-à-vis clinker brings down the overall cost of production of Portland Slag Cement. Accordingly, by benchmarking the usage of slag with the most efficient cement producer, the overall cost of cement production can be reduced considerably. The B.I.S. 455 permits the usage of slag up to 70% in Portland Slag Cement.

### **Kiln Fuel**

Generally, Coal, Pet Coke, Lignite, Furnace Oil and Natural Gas are used as kiln fuel. In India, most of the cement producers either use coal only as kiln fuel or partly use Pet Coke, and Lignite along with coal. Kiln fuel is a major item of cost and accounts for nearly 25% of the total cost of cement production. The consumption of fuel in kiln depends upon various factors, e.g., the process employed, i.e., wet, semi-dry or dry, the production capacity of the kiln, the quality of coal in terms of its net calorific value, the composition of raw meal and thermal efficiency of the entire pyro-processing system.

Coal is the single most important item of fuel used in kilns. In India, coal is procured from Companies owned and controlled by the Government, on the basis of quantities determined by the authorities, which take care of only about two-thirds of the requirements of cement Companies. The balance requirement of coal is obtained either from the same State owned companies through e-auction at very high prices or by imports from other countries at still higher prices. It is, therefore, imperative that the fuel consumption for manufacturing clinker is reduced to the lowest possible levels. Even during the period of price control over cement industry, the various committees set up by the Central Government from time to time to examine the cost structure of the industry and recommend a fair retention price, adopted standard norms for coal and power consumption for wet process, semi-dry process and dry process cement plants. These standard norms were based on the performance of the most efficient plant and thus they served as benchmarks for the other cement plants. Benchmarking in this important area of operations will be highly beneficial to cement Units.

Kilns with capacity of 10,000 tonnes per day have been already set up in some countries, e.g., Japan and China and it is only a matter of time when kilns of similar capacities are set up in India and other cement producing countries. The fuel consumption will be lower in such large sized Kilns and benchmarking in respect of fuel for such Kilns is required to be undertaken accordingly.

### **Transit and Storage Losses**

Considerable losses occur while transporting coal over long distances from the collieries to the plant. The transit losses in coal are mainly due to evaporation of moisture and pilferage en-route. The storage



losses are due to spontaneous combustion and handling at various points. The transit and storage losses account for as much as 3% to 7% of the quantity of coal purchased and paid for. With the rising prices of coal, it is necessary to take proper steps to minimize the transit and storage losses. Benchmarking with the Company which has managed to reduce the transit and storage loss on coal to the lowest level, will be highly beneficial to a cement plant carrying out such exercises.

Transit and storage losses are generally accounted in the usage of coal in kilns or boilers as the case may be. The benchmarking for usage of kiln fuel in terms of K. cal per kilogram of clinker has to be constantly carried out to move to the level achieved by the target Company.

### **Electrical Energy**

Electrical energy also accounts for about 20% of the total cost of cement production. Like kiln fuel, the consumption of power depends upon various factors, e.g., the process employed, viz., wet, semi-dry or dry, the production capacity of the Equipment, the type of cement produced, viz., Ordinary Portland Cement, Portland Pozzolana Cement, Portland Slag Cement or any other variety of cement. The other factors affecting the power consumption are :

- (i) The proportion of various materials, viz., clinker, pozzolanic materials, blast furnace granulated slag, etc. used for cement grinding.
- (ii) The blaine, i.e., the fineness of the product required.
- (iii) The quality of the materials used for grinding, e.g., wet materials cause jamming of mills, which reduces the mill output and increases energy consumption.
- (iv) The maintenance of the mills.
- (v) The output per hour of the mills.

The benchmarking exercise for power consumption should cover each and every department, viz., Crusher, Raw Mills, pyro-processing section, Cement Mills and Packing Plant. Even service departments, e.g., compressor house and workshop, etc. should be covered by this exercise.

The size and vintage of the machinery and equipment has to be necessarily taken into account while undertaking the benchmarking exercise.

Due to production of different types of cement by various Cement Plants, it is advisable to consider the power consumption up to the stage of clinker production in terms of KWH per tonne of clinker. This would provide a more meaningful data for comparing the efficiencies of power consumption of integrated cement plants. There is a large scope of improvement in power consumption and cost in the various processes up to the stage of clinker production and benchmarking exercise should be undertaken for each of these processes. It may be necessary to make some adjustments in power consumption norms on account of the nature of raw materials and fuel used and the size and vintage of the equipment.

After establishing a benchmark for power consumption up to clinker stage, the benchmarking exercise should proceed to cement mills and packing plant. Here again, separate benchmarks should be established for each type of cement ground taking into account the blaine required and percentage of fly ash or slag added to clinker for producing Portland Pozzolana Cement and Portland Slag Cement as the case may be.

Several modern cement plants with an installed capacity of one million tonnes per annum and above, are already operating at much lower power consumption than the older plants. Some large and medium cement plants have already achieved the power consumption level of around 70 KWH per tonne of production of Ordinary Portland Cement. This is another important area where benchmarking exercises should be undertaken on a regular basis. Even a small reduction in electrical energy consumption will result in substantial savings to the cement plants.

Power purchased from State Electricity Boards is very expensive and, therefore, almost all the cement

manufacturing Companies are setting up captive thermal power generating plants. Power generated through captive thermal power plants is 40% to 50% cheaper than the power purchased from the State Electricity Boards. There are other disadvantages in depending upon grid power, e.g., frequent power cuts, power fluctuations, etc., which adversely affect the cement production.

Benchmarking exercises should be undertaken in the different operations of own power plants to improve the efficiencies in terms of optimum power generation, power consumption by auxiliaries, consumption of coal, pet coke, etc. per KWH of power generated, manpower cost per KWH of power generated, load factor and transmission losses, etc.

### **Consumable Stores and Spare Parts**

Several consumable stores and spare parts are required in the operation and maintenance of machinery and equipment in a cement plant. Some of the stores and spare parts, e.g., lubricants, bearings, grinding media, lining plates, firebricks and casting materials, conveyor belts and dumper tyres, etc. are high cost items. Similarly, the stores and spare parts used in the mining machinery and equipment, viz., shovels, rock breakers, drilling machines and dumpers, etc. are quite expensive. Benchmarking practices may be introduced in the maintenance of these equipments so as to get the highest running hours, lowest down time and maximum output per hour. Break-down of vital equipment halts production leading to stoppage of large sections of a plant causing huge losses.

The benchmarking for stores and spare parts will cover the following areas:

- i) Procurement planning
- ii) Establishment of purchase procedures
- iii) Identification of reliable suppliers and their performance rating
- iv) Negotiations of prices with suppliers
- v) Quality and technical specifications
- vi) Inspection of stores on receipt
- vii) Maintenance of performance record of important and costly items.

The cost of stores and spare parts is a significant item in the total cost of production of cement. Benchmarking for stores and spare parts should cover their delivered cost at the plant and the quality of material together with the rate of consumption and impact on cost of production of cement.

The stores and spare parts have a significant impact on the running of the machinery and equipment; it's down time, the output per hour and cost per tonne of cement produced. For instance, There is a wide choice of firebricks to be used in Kilns, e.g., high alumina bricks, basic bricks, etc. and also the casting materials, for relining of kilns. The use of the right mix of bricks in the kiln could prolong the running days of the kiln and reduce production loss on account of stoppage of kiln for relining purposes.

Similarly, the choice of grinding media for the mills can affect the down time of the mills and their hourly output considerably. The reduction in running hours and the output per hour of the mills will directly impact the power consumption and cost of production.

Accordingly, it is essential to find out the practices adopted by the most efficient plant in the matter of usage of firebricks for brick lining in the kilns and the grinding media used in the mills so as to obtain the best lining life of the kilns and the highest output of the mills.

The stores items indicated above, viz., firebricks and grinding media are only illustrative. There are many other items of consumable stores and spare parts, which are required to be considered carefully because they also have varying impact on the efficient running of the plant, the output of the machines and the overall cost of production. Benchmarking should be attempted for all important items of stores and spare parts so that the enterprise is able to compete with the most efficient producer.



## **Packing Materials**

In India, bulk loading of cement is insignificant and cement is despatched from the plants after packing in bags. Most of the plants use HDPE bags and only a few plants use paper bags.

The quality of bags is very important in the matter of proper carriage of material by rail, road, sea or river transport. The specifications in respect of quality of bags generally cover the following requirements:

- (i) Length and width of bags and size of valve
- (ii) Weight of bags
- (iii) Tensile and seam strength of bags
- (iv) Elongation of bags.

The basis of testing the bags is provided in the B.I.S. specification Nos. IS:11652-2000 and IS:1969:1985.

It is very important to ensure that the bags conform to the prescribed specifications as the bags undergo multiple handling from the time of despatch from the plant till they reach the customer. The labour handling the bags at various stages uses hooks, which may damage the bags if the bags do not conform to the prescribed specifications. Many cement producers engage Inspection Agencies, who inspect the quality of bags at the bag manufacturers' premises before despatch of the bags to cement plants.

Benchmarking is essential in the matter of procurement of bags, inspection procedure and handling of bags in the packing plant and en-route to the customer. It is important to ensure good appearance of bags at the time of delivery to the customer as it affects the brand equity of the cement producer. The practices followed by the most efficient cement producer in these matters may be adopted by the enterprise so as to be at par with the best producer in this vital area of cement business. Burstage of bags per tonne of cement despatched could also be a parameter for benchmarking.

## **Manpower**

The old cement plants with an annual production capacity of less than a million tonnes are burdened with a large number of employees, most of whom are covered by cement wage board award. The employees in cement industry are amongst the highest paid workmen in India. The minimum wage including incidentals payable to the lowest grade unskilled worker in cement industry effective from 1<sup>st</sup> September 2008 was Rupees 1,69,632/- per annum. This wage is applicable to an unskilled worker at the start of his employment in a cement Company. There is a clamour for further improvement in the wage structure by the workers' unions and their Federation.

The modern cement plants with large capacity kilns, mills and other equipment and high level of automation and computerization and also by outsourcing of non-process, non-core activities, are able to operate with substantially lower manpower than the older plant. This gives the modern plants a distinct cost advantage over the older plants.

In order to compete with the large plants, the older plants can take several steps, e.g., optimizing, debottlenecking, improving instrumentation and carrying out expansions of the existing capacity. Rationalization of manpower, productivity optimization, outsourcing the non core activities and similar other measures can be adopted by such plants to reduce the cost of manpower.

It is very important to take up benchmarking exercises, to ascertain the number of persons deployed in various departments of the plant by the most efficient cement unit. Thereafter, studies should be carried out to assess the surplus manpower, deployed for various jobs in all departments of the plant. By undertaking productivity studies and position analysis and outsourcing non-process and non-core activities, benchmarking in this important area will be facilitated. Surplus manpower could be encouraged to leave the plant by offering attractive compensation under voluntary retirement schemes. Training to acquire multi-skills may be imparted to the remaining workers so as to enrich their knowledge and competence and, in turn, utilize their services for a variety of jobs. It is essential to



enlist the support and cooperation of all the supervisory staff for making the benchmarking exercise a success. For benchmarking with the target plant, the man-days or man-hours per tonne of cement produced and cost of manpower per ton of cement produced may be considered.

### **Cement Transportation**

Cement is mainly despatched from the manufacturing plants by railway wagons or by road transport. In India, only a small quantity of cement is despatched in loose condition, i.e., without packing and bulk of the material is transported duly packed in HDPE bags. Wherever it is feasible to do so, cement despatches are also made through river or sea route.

Large quantities of cement are transported over long distances to markets located at far-off places. The cement plants are generally located in remote areas near the limestone mines and the freight on cement despatches is almost equal to 25% of the cost of sales. For such a crucial item of cost, it is of paramount importance for cement plants to carry out benchmarking exercises so as to match the transportation cost of the most efficient cement Unit. Such benchmarking exercises are undertaken on a continuous basis.

Logistics play a crucial role in keeping the incidence of freight at the lowest level. This will include, inter-alia, the following steps:

- (i) Selection of the most suitable markets.
- (ii) Location of sales depots at the most appropriate places.
- (iii) Choosing the most economical mode of transport.
- (iv) Negotiating the most favourable transportation rates with the transporters.
- (v) Minimizing the transit losses and damage to cement bags.
- (vi) Maintaining the optimal inventory of cement bags at the godowns.

Cement is a bulk material and it cannot be stored in large quantities. Further, the storage of cement beyond a period of 2/3 months leads to deterioration in its quality. It is, therefore, necessary to maintain a continuous flow of the material from the plant to the customers. The logistics and the marketing teams of the enterprise have to coordinate their functions properly to ensure a smooth flow of material from the plant to the godowns for onward dispatch to the dealers/customers. Transport of cement over long distances is generally arranged through railway wagons. Railway freight is invariably lower than road freight and larger quantities can be carried to various markets in lesser time. However, rail transport involves multiple handling of the material and higher incidence of damage to cement bags on account of use of hooks by labour while unloading the bags at the railway siding, loading into trucks, again unloading at the godowns and re-loading the bags into trucks for onward despatch to dealers/customers. At several railway sidings, covered sheds and platforms are not provided, which makes the unloading operations difficult and exposes the cement bags to risk of getting damaged particularly during the rainy season.

Road transport is costlier than rail transport due to lower load carrying capacity of trucks, poor road condition in smaller towns and delay occurring at various check posts, especially when inter-state movement of vehicles is involved. The advantage of road movement of cement is on account of savings in handling of material and damage to cement bags is minimized. The cement bags are loaded in trucks at the plant and are unloaded only at the godown at the destination or at customers' premises, thus reducing substantially the handling expenses and loss due to damage to bags.

The choice of rail or road transport for despatch of cement is to be made after considering several factors, e.g., availability of railway rakes and trucks for the desired destinations, the difference in rail and road freight, the chances of damage to material en-route or at destination due to rains, etc., the incidence of demurrage/ wharfage at the destination rail-head due to delay in unloading and removal of material from the railway siding within the time allowed by the railways, the expenses for



multi-handling of bags and the incidence of loss of material due to damage to bags during transit and unloading/loading operations.

If cement silos are full at the plant due to disruption in despatches, cement grinding will have to be stopped leading to heavy production loss. Therefore, the flow of cement despatches from the plant to the market must continue and to achieve that purpose, a proper despatch planning and arrangement for transport of material is essential.

In order to combat competition effectively, an enterprise must carry out detailed studies of the practices followed by the leading cement producer in the matter of organizing the logistics function, the marketing strategies, transport management and warehousing operations. Such studies are required to be undertaken on a continuous basis as several changes take place from time to time, e.g., new rail lines may be laid down, which may make available a different route from the plant to various markets making it more economical to transport the material through such a route; or a bridge may be constructed on a river at a place, which may open up new markets entailing lower freight; or some Special Economic Zone (SEZ) may be set up in an area, which may be away from the normal marketing Zone of the plant, but may yield higher price realization on account of excise duty exemption and other benefits. The markets, which are less profitable at one time due to high incidence of freight or any other reason, may turn highly lucrative at some other time on account of rise in demand for the product owing to large projects coming up in the area and consequent increase in selling prices. Therefore, the enterprise has to be constantly watchful of the ongoing developments and frame its policies as per the dynamics of the market situation.

#### **Works Overhead, Administrative Overhead and Selling and Distribution Overhead**

These are indirect expenses incurred for operating and managing the plant and selling the products. Various functions, e.g., engagement of workers, time-keeping, wage computation and payment, compliance of statutory provisions under Factories Act and various other enactments, including provisions relating to protection of environment, security, purchase of raw materials, bags, stores and spare parts, store-keeping, accounting, sampling and test checking the incoming materials and the products manufactured at the plant, rent, rates and taxes, insurance of assets, other services including maintenance of buildings, water supply, colony, etc. form part of Works Overhead. Formulation of policies, general management, supervision and control of the enterprise and various other functions, e.g., financing, audit, legal and secretarial matters, etc. comprise administrative overhead. The marketing functions including logistics, transport management, directing and controlling the sales force, collecting market intelligence and watching the activities of the competitors, setting up warehouses, supply chain management, fixing prices of products and dealing with customers on day-to-day basis, preparing invoices for products sold and recovery of the amounts due to the enterprise, advertisement for brand building and compliance with laws relating to excise duty, vat/sales tax, etc. are part of selling and distribution overhead. The overheads aggregate to a substantial amount and differ from Unit to Unit. In several cement Companies, these expenses account for 12% to 15% of the cost of sales excluding outward freight. Companies with old plants with large labour force have a still higher incidence of overheads. Budgetary control systems including Zero budgeting are some of the measures adopted by Companies to reduce the incidence of such expenses.

To combat competition, it is highly useful to carry out benchmarking exercises by closely studying the practices adopted by the most efficient enterprise in the matter of deployment of work force, automation of operations, computerization of work, outsourcing the non-process and non-core activities, maximizing productivity of men and machines, elimination of wastes, streamlining of systems and procedures, exercising strict control over cost and quality at each and every stage of production and toning up the administration at all levels. Detailed and in-depth studies are required to be undertaken to locate the weak areas and to improve the performance by adopting the best practices followed by the most efficient enterprise.

## 3.2 BUSINESS PROCESS RE-ENGINEERING

Business Process Reengineering involves changes in structures and in processes within the business environment. The entire technological, human, and organizational dimensions may be changed in BPR.

Information Technology plays a major role in Business Process Reengineering as it provides office automation, it allows the business to be conducted in different locations, provides flexibility in manufacturing, permits quicker delivery to customers and supports rapid and paperless transactions. In general it allows an efficient and effective change in the manner in which work is performed.

### What is the Business Process Re-engineering

The globalization of the economy and the liberalization of the trade markets have formulated new conditions in the market place which are characterized by instability and intensive competition in the business environment. Competition is continuously increasing with respect to price, quality and selection, service and promptness of delivery. Removal of barriers, international cooperation, technological innovations cause competition to intensify. All these changes impose the need for organizational transformation, where the entire processes, organization climate and organization structure are changed. Hammer and Champy provide the following definitions:

- Reengineering is the fundamental rethinking and radical redesign of business processes to achieve dramatic improvements in critical contemporary measures of performance such as cost, quality, service and speed.
- Process is a structured, measured set of activities designed to produce a specified output for a particular customer or market. It implies a strong emphasis on how work is done within an organization." (Davenport 1993).

Each process is composed of related steps or activities that use people, information, and other resources to create value for customers as it is illustrated in the following example.

### An example of a business process: Credit card approval in a bank.

An applicant submits an application. The application is reviewed first to make sure that the form has been completed properly. If not, it is returned for completion. The complete form goes through a verification of information. This is done by ordering a report from a credit company and calling references. Once the information is verified, an evaluation is done. Then, a decision (yes or no) is made. If the decision is negative, an appropriate rejection letter is composed. If the decision is positive, an account is opened, and a card is issued and mailed to the customer.

The process, which may take a few weeks due to workload and waiting time for the verifications, is usually done by several individuals

Business processes are characterized by three elements: the inputs, (data such customer inquiries or materials), the processing of the data or materials (which usually go through several stages and many necessary steps that turns out to be time and money consuming), and the outcome (the delivery of the expected result). The problematic part of the process is processing.

Business process reengineering mainly intervenes in the processing part, which is reengineered in order to become less time and money consuming.

BPR focuses on team building operations around processes and building a company mentality to personnel. The objective of the technique is to build customer-oriented effective organizations. The customer does not care if the accounting department works adequately or not, he wants to see his order processed as it should be.



## How can BPR be applied to an organization?

When British Telecom had announced their Business Plan, all competitors were eager to find out who would be the new CEO of the organization. To the surprise of all the new CEO was the customer. The company had decided to transform all the operations of the organization the way customers wanted them to operate. The most important action in applying BPR is the company's strategic goal to provide customer oriented services. BPR is a technique used to implement this type of organizational structure.

Having the management commitment for change, another very important factor for implementing BPR, is the enabling role of Information Technology. The way that businesses are organized around departments is very logical since, for instance, there were physical barriers in the communication of the accounting department with production department. (The warehouse could be in another location in another part of the city). So it wasn't possible for a cross-functional team to communicate efficiently. In the 90s telecommunication technologies were becoming abundant and low costing BPR was becoming a world-wide applicable managing technique for business upgrade, enabled by the technology. Employees can easily operate as a team using intranets/extranets, workflow and groupware applications, eliminating distances. We can work together even though we are located in different places.

**Empowering people.** Empowerment means giving people the ability to do their work: the right information, the right tools, the right training, the right environment, and the authority they need. Information systems help empower people by providing information, tools and training.

**Providing Information.** Providing information to help people perform their work is a primary purpose of most information systems although they provide information in many different ways. Some systems provide information that is essential in informing a business process, such as the prices used to create a customer's bill at a restaurant. Other systems provide information that is potentially useful but can be used in a discretionary manner, such as medical history information that different doctors might use in different ways.

**Providing Tools.** In addition to providing the right information, empowering people means giving them the right tools. Consider the way planning analysts produce consolidated corporate plans based on plans of individual divisions and departments. If the plans are submitted on paper, it is a major task to add up the numbers to determine the projected corporate bottom line. When the plan is changed during a negotiation process, the planning analyst has to recalculate the projected results. With the right tools, the numerical parts of the plans arrive in a consistent, electronic format permitting consolidation by a computer. This leaves the analyst free to do the more productive work of analysing the quality of the plan.

**Providing Training.** Since information systems are designed to provide the information needed to support desired work practices, they are often used for training and learning. As shown by an expert system and a decision simulator, they sometimes provide new and unique training methods. IBM developed an expert system for fixing computer disk drives. The expert system was

an organized collection of the best knowledge about fixing these disk drives, and it fostered rapid and efficient training. Before the system was developed, technicians typically took between 1 and 16 months to become certified, but with the expert system, training time dropped 3 to 5 months.

**Eliminating Unproductive Uses of Time.** Information systems can reduce the amount of time people waste doing unproductive work. A study of how professionals and managers at 15 leading U.S. corporations spent their time concluded that many professionals spent less than half of their work time on activities directly related to their functions. Although the primary function of salespeople is selling, the time breakdown for salespeople averaged 33 percent spent on selling, 39 percent spent on prospecting an selling, 3 percent on servicing accounts, 19 percent on doing administrative chores, and 6 percent on training. Better use of information systems could save much of their unproductive time performing chores such as collecting product or pricing information, determining order status for a customer, resolving invoice discrepancies, and reporting of time and expenses.

**Eliminating Unnecessary Paper.** One common way to improve data processing is to eliminate unnecessary paper. Although paper is familiar and convenient for many purposes, it has major disadvantages. It is bulky, difficult to move from place to place, and extremely difficult to use for analysing large amounts of data. Storing data in computerized form takes much less physical space and destroys fewer forests, but that is only the beginning. It makes data easier to analyze, easier to copy or transmit, and easier to display in a flexible format. Compare paper telephone bills with computerized bills for a large company. The paper bills identify calls but are virtually impossible to analyze for patterns of inefficient or excessive usage.

**Eliminating Unnecessary Variations in the Procedures and Systems.** In many companies, separate departments use different systems and procedures to perform essentially similar repetitive processes, such as paying employees, purchasing supplies, and keeping track of inventories. Although these procedures may seem adequate from a totally local viewpoint, doing the same work in different ways is often inefficient in a global sense. Whenever the systems must change with new technology, new regulations, or new business issues, each separate system must be analysed separately, often by someone starting from scratch.

**Minimizing the Burden of Record Keeping, Data Handling, and General Office Work.** Since processing data is included in most jobs, improving the way people process data is an obvious place to look for information system applications. Focus on basic data processing tasks : Reducing the burden of record keeping means being more efficient and effective with the six components of data processing. Those components are capturing, transmitting, storing, retrieving, manipulating, and displaying data. Capture data automatically when generated: Capturing data automatically at the time of data generation is especially important in minimizing the burden of record keeping.

In depth, BPR assumes that the current processes in a business are inapplicable and suggest completely new processes to be implemented by starting over. Such a perspective enables the designers of business processes to disassociate themselves from today's process, and focus on a new process.

The BPR characteristics - outcomes include the following:

- Several jobs are combined into one.
- Decision-making becomes part of the job of employees (employee empowerment).
- Steps in the processes are performed in natural order, and several jobs get done simultaneously.
- Processes have multiple versions. This enables the economies of scale that result from mass production, yet allows customization of products and services.
- Work is performed where it makes the most sense.
- Controls and checks and other non-value-added work are minimized.
- Reconciliation is minimized by cutting back the number of external contact points and by creating business alliances.
- A single point of contact is provided to customers.
- A hybrid centralized/decentralized operation is used.

BPR is achieving dramatic performance improvements through radical change in organizational processes, re-architecting of business and management processes. It involves the redrawing of organizational boundaries, the reconsideration of jobs, tasks, and skills. This occurs with the creation and the use of models. Whether those be physical models, mathematical, computer or structural models, engineers build and analyze models to predict the performance of designs or to understand the behavior of devices. More specifically, BPR is defined as the use of scientific methods, models and tools to bring about the radical restructuring of an enterprise that result in significant improvements in performance.



Redesign, retooling and re-orchestrating form the key components of BPR that are essential for an organization to focus on the outcome that it needs to achieve. The outcome pursued should be an ambitious outcome (as for instance, are a 24 hour delivery to any customer anywhere in the world, approval of mortgage loans within 60 minutes of application, or ability to have on-line access to a patient's medical records no matter where they are in any major city in the world). These types of visionary goals require rethinking the way most organizations do business, careful redesign. They will additionally need very sophisticated supporting information systems and a transformation from a traditional organizational structure to a network type organization.

In resuming, the whole process of BPR in order to achieve the above mentioned expected results is based on key steps-principles which include redesign, retool, and reorchestrate.

Each step-principle embodies the actions and resources as presented in the table below.

REDESIGN	RETOOL	REORCHESTRATE
<ul style="list-style-type: none"> <li>• Simplify</li> <li>• Standardize</li> <li>• Empowering</li> <li>• Employeeship</li> <li>• Groupware</li> <li>• Measurements</li> </ul>	<ul style="list-style-type: none"> <li>• Networks</li> <li>• Intranets</li> <li>• Extranets</li> <li>• Work-Flow</li> </ul>	<ul style="list-style-type: none"> <li>• Synchronize</li> <li>• Processes</li> <li>• IT</li> <li>• Human resource</li> </ul>

### 3 Rs of re-engineering

Creating the new enterprise involves considerable change in virtually everything to do with people's working lives. Rather than fixing the old, we set out to create the new. There is a fundamental transformation occurring in business - in terms of its structure, processes, people, and technology. The table following presents the changes in that occur in the business under BPR.

#### Changes in the World of Work

From Conventional	To BPR
Functional departments	Process Teams
Simple tasks (division of labor)	Empowered employees
Controlled people (by management)	Multidimensional work
Training of employees	Education of employees
Compensation for skill and time spent	Compensation for results
Pay raises based on promotions and seniority	Low pay plus high performance-related bonuses
Advancement based on ability	Advancement based on performance
Protective organizational culture	Productive organizational structure
Managers supervise and control	Managers coach and advise
Hierarchical organizational structure	Horizontal (flat) structure
Executives as scorekeepers	Executives as leaders
Separation of duties and functions	Cross-functional teams
Linear and sequential processes	Parallel process
Mass production	Mass customization

### Objectives of BPR

When applying the BPR management technique to a business organization the implementation team effort is focused on the following objectives:

**Customer focus.** Customer service oriented processes aiming to eliminate customer complaints.

**Speed.** Dramatic compression of the time it takes to complete a task for key business processes. For instance, if process before BPR had an average cycle time 5 hours, after BPR the average cycle time should be cut down to half an hour.

**Compression.** Cutting major tasks of cost and capital, throughout the value chain. Organizing the processes a company develops transparency throughout the operational level reducing cost. For instance the decision to buy a large amount of raw material at 50% discount is connected to eleven cross checkings in the organizational structure from cash flow, inventory, to production planning and marketing. These checkings become easily implemented within the cross-functional teams, optimizing the decision making and cutting operational cost.

**Flexibility.** Adaptive processes and structures to changing conditions and competition. Being closer to the customer the company can develop the awareness mechanisms to rapidly spot the weak points and adapt to new requirements of the market.

**Quality.** Obsession with the superior service and value to the customers. The level of quality is always the same controlled and monitored by the processes, and does not depend mainly on the person, who servicing the customer.

**Innovation.** Leadership through imaginative change providing to organization competitive advantage.

**Productivity.** Improve drastically effectiveness and efficiency.

In order to achieve the above mentioned adjectives the following BPR project methodology is proposed.

#### Methodology of a BPR project implementation

BPR is world-wide applicable technique of business restructuring focusing on business processes, providing vast improvements in a short period of time. The technique implements organizational change based on the close coordination of a methodology for rapid change, employee empowerment and training and support by information technology. In order to implement BPR to an enterprise the followings key actions need to take place:

- Selection of the strategic (added-value) processes for redesign.
- Simplify new processes - minimize steps - optimize efficiency - (modeling).
- Organize a team of employees for each process and assign a role for process coordinator.
- Organize the workflow - document transfer and control.
- Assign responsibilities and roles for each process.
- Automate processes using IT (Intranets, Extranets, Workflow Management)
- Train the process team to efficiently manage and operate the new process
- Introduce the redesigned process into the business organizational structure

Most reengineering methodologies share common elements, but simple differences can have a significant impact on the success or failure of a project. After a project area has been identified, the methodologies for reengineering business processes may be used. In order for a company, aiming to apply BPR, to select the best methodology, sequence processes and implement the appropriate BPR



plan, it has to create effective and actionable visions. Referring to 'vision' we mean the complete articulation of the future state (the values, the processes, structure, technology, job roles and environment) For creating an effective vision, five basic steps are mentioned below.

- the right combination of individuals come together to form an optimistic and energized team
- clear objectives exist and the scope for the project is well defined and understood
- the team can stand in the future and look back, rather than stand in the present and look forward
- the vision is rooted in a set of guiding principles.

All methodologies could be divided in general 'model' stages:

**The Envision stage** : the company reviews the existing strategy and business processes and based on that review business processes for improvement are targeted and IT opportunities are identified.

**The Initiation stage** : project teams are assigned, performance goals, project planning and employee notification are set.

**The Diagnosis stage** : documentation of processes and sub-processes takes place in terms of process attributes (activities, resources, communication, roles, IT and costs).

**The Redesign stage** : new process design is developed by devising process design alternatives and through brainstorming and creativity techniques.

**The Reconstruction stage** : management technique changes occur to ensure smooth migration to the new process responsibilities and human resource roles.

**The Evaluation stage** : the new process is monitored to determine if goals are met and examine total quality programs

### 3.2.2 Principles:

Hammer and Champy felt that the design of workflow in most large corporations was based on assumptions about technology, people, and organizational goals that were no longer valid. They suggested seven principles of reengineering to streamline the work process and thereby achieve significant levels of improvement in quality, time management, and cost:

1. Organize around outcomes, not tasks.
2. Identify all the processes in an organization and prioritize them in order of redesign urgency.
3. Integrate information processing work into the real work that produces the information.
4. Treat geographically dispersed resources as though they were centralized.
5. Link parallel activities in the workflow instead of just integrating their results.
6. Put the decision point where the work is performed, and build control into the process.
7. Capture information once and at the source.

By the mid-1990's, BPR gained the reputation of being a nice way of saying "downsizing." According to Hammer, lack of sustained management commitment and leadership, unrealistic scope and expectations and resistance to change prompted management to abandon the concept of BPR and embrace the next new methodology, enterprise resource planning (ERP).

Business Process Re-engineering is also known as Business Process Redesign, Business Transformation, or Business Process Change Management.



### 3.2.3 Steps of Business process Re- Engineering:

Assuming that a company has decided its processes are inefficient or ineffective, and therefore in need of redesign, how should it proceed? This is a straight forward activity, but *Davenport & Short (1990)* prescribe a five-step approach to BPR:

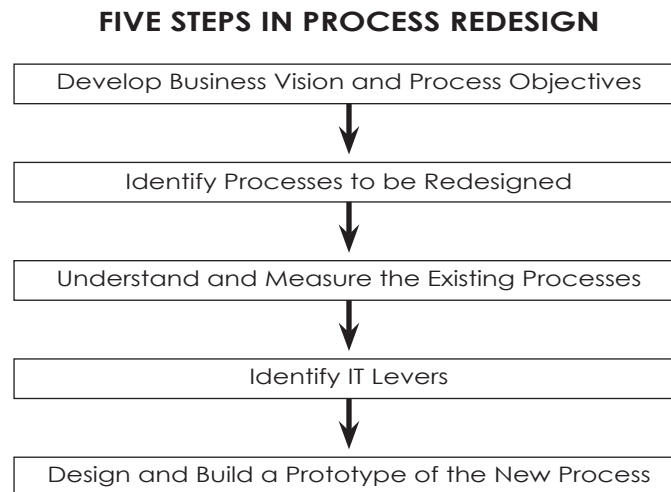

**(1) Develop Business Vision and Process Objectives:**

BPR is driven by a business vision which implies specific business objectives such as Cost Reduction, Time Reduction, Output Quality Improvement, Quality of Work life (QWL)/Learning/Empowerment.

**(2) Identify Processes to be Redesigned:**

Most firms use the *High-Impact* approach which focuses on the most important processes or those that conflict most with the business vision. Lesser number of firms use the *Exhaustive* approach that attempts to identify all the processes within an organization and then prioritize them in order of redesign urgency.

**(3) Understand and Measure the Existing Processes:**

Understanding and measuring the existing processes before redesigning them is especially important, because problems must be understood so that they are not repeated. On the other hand, accurate measurement can serve as a baseline for future improvements.

**(4) Identify IT Levers:**

In the broadest sense, all of IT's capabilities involve improving coordination and information access across organizational units, thereby allowing for more effective management of task interdependence. An awareness of IT capabilities can -and should- influence process design. Therefore, the role of IT in a process should be considered in the early stages of its redesign.

**(5) Design and Build a Prototype of the New Process:**

The actual design should not be viewed as the end of the BPR process. Rather, it should be viewed as a prototype, with successive iterations expected and managed. Key factors and tactics to consider in process design and prototype generation include using IT as a design tool, understanding generic design criteria, and creating organizational prototypes.

These prototypes of business process changes and organizational redesign initiatives, after agreement by owners and stakeholders, would be implemented on a pilot basis, examined regularly for problems and objective achievement, and modified as necessary. As the process approached final acceptance, it would be phased into full implementation.

Another views for BPR of pictorial description is given below:

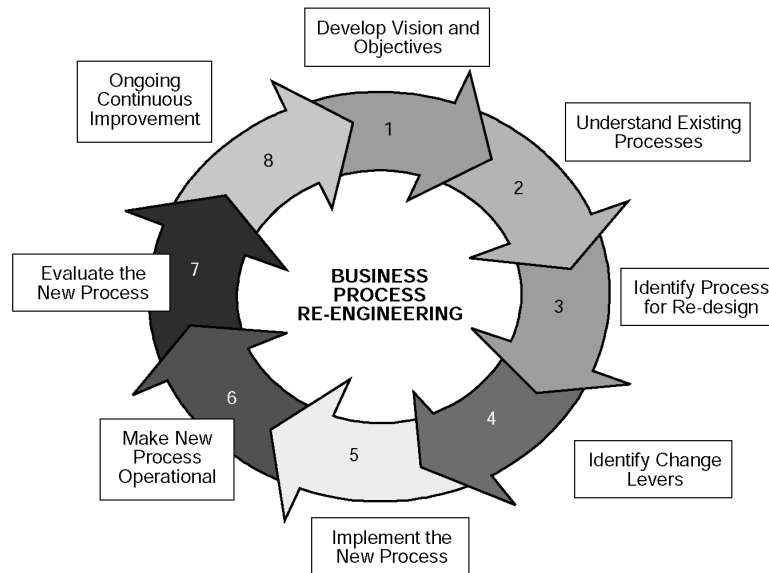

Source: Vakola *et al.* (1998)

### 3.2.4 BPR Tools and Techniques

The various definitions of BPR suggest that the radical improvement of processes is the goal of BPR. They do not, however, refer specifically to the tools and techniques used in reengineering business processes.

#### (i) Process visualization:

While many authors refer to the need to develop an ideal "end state" for processes to be reengineered, some suggest that the key to successful reengineering lies in the development of a vision of the process.

#### (ii) Process mapping /operational method study:

Process mapping and operational method studies have been incorporated into tools such as IDEF0 (Integrated Definition Method), DFD (Data Flow Diagrams), OOA (Object Oriented Analysis), and Prince2 (Process Based Project Management).

#### (iii) Change management:

Since management of change is the largest task in reengineering, the human side of reengineering, in particular the management of organizational change should not be neglected.

#### (iv) Benchmarking:

Benchmarking forms an integral part of reengineering, since it allows the visualization and development of processes which are known to be in operation in other organizations.

#### (v) Process and customer focus:

The primary aim of BPR, is to redesign processes with regard to improving performance from the customer's perspective.

It should be noted that few authors refer to any single technique when discussing BPR. Most incorporate a mixture of tools, although the nature of the mix depends on the application, whether it be hard (technological) or soft (management of people).

While some authors appear to suggest that tools and techniques are the key, most authors suggest that a strategic approach to BPR, and the development of a BPR strategy is the key to success. There seems

little doubt in either the literature or in practice that efforts on the scale of BPR must be strategically driven and supported by senior management if they are to succeed.

### 3.2.5 The Role of Information Technology

Information technology (IT) has historically played an important role in the reengineering concept. It is considered by some as a major enabler for new forms of working and collaborating within an organization and across organizational borders.

Early BPR literature identified several so called *disruptive technologies* that were supposed to challenge traditional wisdom about how work should be performed.

- Shared databases, making information available at many places
- Expert systems, allowing generalists to perform specialist tasks
- Telecommunication networks, allowing organizations to be centralized and decentralized at the same time
- Decision-support tools, allowing decision-making to be a part of everybody's job
- Wireless data communication and portable computers, allowing field personnel to work office independent
- Interactive videodisk, to get in immediate contact with potential buyers
- Automatic identification and tracking, allowing things to tell where they are, instead of requiring to be found
- High performance computing, allowing on-the-fly planning and revisioning

In the mid-1990s, especially workflow management systems were considered as a significant contributor to improved process efficiency. Also ERP (Enterprise Resource Planning) vendors, such as SAP, JD Edwards, Oracle, PeopleSoft, positioned their solutions as vehicles for business process redesign and improvement.

### 3.2.6 Research and methodology

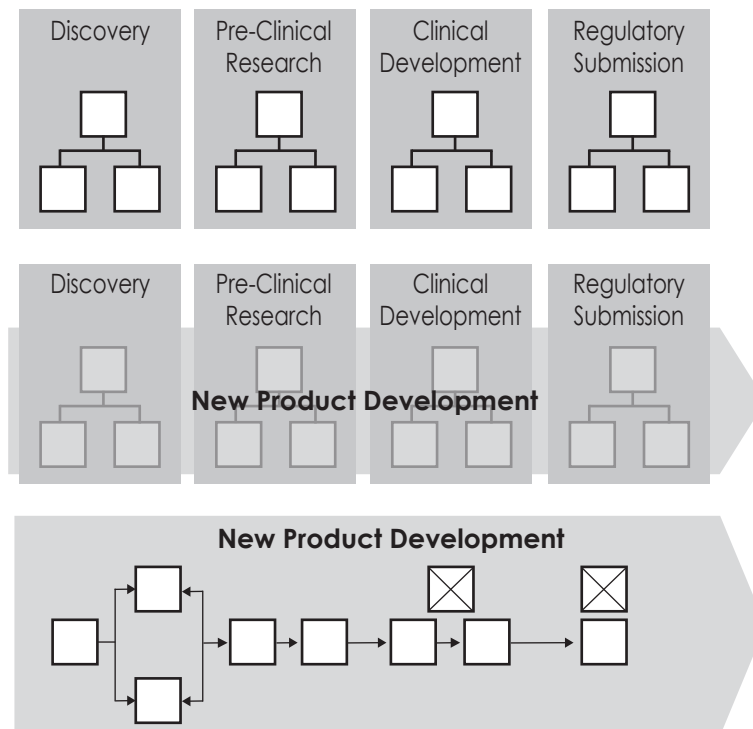



### Model Based on PRLC approach

Although the labels and steps differ slightly, the early methodologies that were rooted in IT-centric BPR solutions share many of the same basic principles and elements. The following outline is one such model, based on the PRLC (Process Re-engineering Life Cycle) approach developed by Guha. Simplified schematic outline of using a business process approach, exemplified for pharmaceutical R&D

1. Structural organization with functional units
2. Introduction of New Product Development as cross-functional process
3. Re-structuring and streamlining activities, removal of non-value adding tasks

Benefiting from lessons learned from the early adopters, some BPR practitioners advocated a change in emphasis to a customer-centric, as opposed to an IT-centric, methodology. One such methodology, that also incorporated a Risk and Impact Assessment to account for the impact that BPR can have on jobs and operations, was described by Lon Roberts (1994). Roberts also stressed the use of change management tools to proactively address resistance to change — a factor linked to the demise of many reengineering initiatives that looked good on the drawing board.

Some items to use on a process analysis checklist are: Reduce handoffs, Centralize data, Reduce delays, free resources faster, Combine similar activities. Also within the management consulting industry, a significant number of methodological approaches have been developed.

#### 3.2.7 Relationship between BPR and Information Technology

Information Technology (IT) refers to **“the capabilities offered by computers, software applications, and telecommunications”**. (Davenport & Short, 1990)

**Hammer (1990)** considers IT as the key enabler of BPR, which he considers as “radical change.” He prescribes the use of IT to challenge the assumptions inherent in the work processes that have existed since long before the advent of modern computer and communications technology.

**Davenport & Short (1990)** argue that BPR requires taking a broader view of both IT and business activity, and of the relationships between them. IT and BPR have recursive relationship. IT capabilities should support business processes, and business processes should be in terms of the capabilities IT can provide. *Davenport & Short (1990)* refer to this broadened, recursive view of IT and BPR as “the new industrial engineering”.

Business processes represent a new approach to coordination across the firm; IT's promise -and its ultimate impact- is to be the most powerful tool for reducing the costs of coordination. Finally, *Davenport & Short (1990)* outline the following capabilities that reflect the roles that IT can play in BPR: Transactional, Geographical, automatically, Analytical, Informational, Sequential, Knowledge Management, Tracking, and Disintermediation.

On the other hand, **Grover & Malhotra (1997)** note that conceptually, an organization should be able to redesign a business process without the aid of IT, and that, however many recent successes in reengineering would be difficult to consummate without the enabling IT. Application of shared computing resources and telecommunication technologies, workflow software, and CAD/CAM systems are powerful enablers of process change.

Finally, **Attaran (2003)** categorizes IT roles in BPR into three phases:

**Phase 1:** Before the process design (as an enabler)

- Create infrastructures and manage information that support evolving organization
- Foster process thinking in organizations
- Identify and select process for redesign

- Participate in predicting the nature of change and anticipate the information needs to support that change
- Educate IT staff in non-technical issues such as marketing, customer relationships, etc.
- Participate in designing measures of success/failures of reengineering

**Phase 2:** During the process design (as a facilitator)

- Bring vast amounts of information into the process
- Bring complex analytical methods to bear on the process
- Enhance employees' ability to make more informed decisions with less reliance on formal vertical information flows
- Identify enablers for process design
- Capture the nature of proposed change and match IT strategy to that change
- Capture and disseminate knowledge and expertise to improve the process
- Communicate ongoing results of the BPR effort
- Transform unstructured processes into routinized transactions
- Reduce/replace labor in a process
- Measure performance of current process
- Define clear performance goals and objectives to drive the implementation
- Define the boundaries and scope of the process

**Phase 3:** During the implementation (as an implementor)

- Create a digital feedback loop
- Establish resources for critical evaluation of the reengineered process
- Improve IT processes to meet increasing needs of those divisions that have gone under reengineering processes
- Institute a program of "cleanup" and damage control in case of failure
- Communicate ongoing results of the BPR effort
- Help to build commitment to BPR
- Evaluate the potential investment and return of reengineering efforts

### **3.2.8 Difference between TQM and BPR**

Total Quality Management (TQM) is an approach to improving the competitiveness, effectiveness and flexibility of a whole organization. It is essentially a way of planning, organizing and understanding each activity, and depends on each individual at each level. TQM involves placing the customer as the focal point of operations. Its aim is to continuously improve process performance in order to satisfy customer requirements. At the center of TQM is the concept of the management of processes, and the existence of internal suppliers and customers within organizations. **(O'Neill & Shoal, 1999)**

BPR also emphasizes focus on the process. However, BPR is much more radical than TQM. Quality approaches concentrate on improving existing processes; process reengineering starts from scratch to create new processes without the constraints of existing methods, people, technology, management systems, or organizational structures. **(Chang, 1994)**

The major differences between Quality Improvement and Process Reengineering approaches are provided by **Chang (1994)** in the following table:

<b>Differences Between Total Quality Management(TQM) and Business Process Reengineering (BPR)</b>		
<b>Major Factor</b>	<b>TQM Approach</b>	<b>BPR</b>
<b>Senior-management involvement</b>	Hands-on initially, and becoming more reinforcement-oriented	Hands-on, active involvement throughout the effort
<b>Intensity of team-member involvement</b>	Ongoing involvement on an as-needed, part-time basis	Ongoing involvement for a specified duration on a full-time basis
<b>Improvement goals</b>	Focus on incremental improvements over a period of time	Focus on dramatic improvements in a short time frame
<b>Implementation approach</b>	Emphasis on improving current work processes	Emphasis on creating new ways of doing things
<b>Magnitude of organizational change</b>	Limited disruption to existing systems and structures	Radical changes to existing systems and structures
<b>Breadth of focus</b>	Addresses narrowly defined work processes	Addresses processes that span entire business units
<b>Use of benchmark data</b>	Used after process improvement, to compare data	Used on front end, to assist with process selection
<b>Dependence on information systems</b>	Information systems used for data collection and interpretation	Information systems used as a central enabler with on-line access

Quality specialists tend to focus on incremental change and gradual improvement of processes, while proponents of reengineering often seek radical redesign and drastic improvement of processes. On the other hand, **Davenport & Short (1990)** suggest that TQM and BPR can -and should- form an integrated strategic management system within organizations.

### 3.2.9 Successful Examples of BPR

Until this section, we have examined the theoretical background of BPR. But what does reengineering look like in the real world? Here is how some mainstream companies such as Ford Motor and IBM Credit have done it.

#### **Case 1: Ford Motor Co. reengineering its accounts payable processes (adapted from Hammer, 1990)**

In the early 1980s, Ford Motors, America's leading motor company, put its Accounts Payable Department under the scanner. The department employed around 500 employees, only in the North America itself. The senior management wanted to reduce the head count by around 20%, by installation of new IT systems. A group of managers from Ford visited the Mazda office in Japan and found that the work done by 500 people in Ford was being done by just 5 employees in Mazda. While Ford was trying to make its head count come down to 400, the difference in absolute numbers was enormous. Taking into consideration the fact that even though Mazda is much smaller in size as compared to Ford, the Accounts payable Department of Ford was five times the size it should be. The managers of Ford started analyzing the As- Is process.

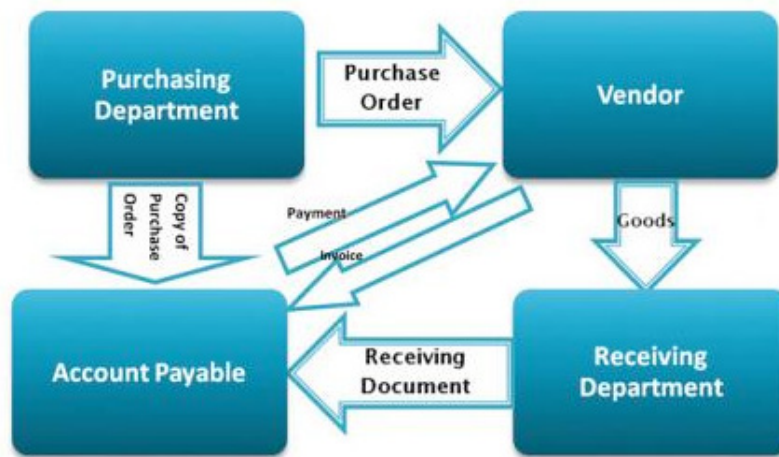

The As-Is process is shown in the figure above. The purchasing department sends the purchase order to the vendor, and also sends a copy of the same to the accounts payable department. When the goods are received by the material control department, it sends a copy of the receiving document to the accounts payable department. The vendor sends an invoice to the accounts payable department, which then matches the purchase order against the invoice and the receiving document, which is known as three-way matching. In case they match, the accounts payable department made the payment. In case of a mismatch, a clerk from the accounts payable department investigates the discrepancy, holds up payments, generates documents, and carries out all other necessary responsibilities. Under the As-Is process, it was the responsibility of the accounts payable department to match 14 data items between the invoice, the receipt record, and the purchase order, before the payment could be sent to the vendor.

When Ford management sat down to discuss the possible scope of process improvement, they contemplated a more efficient check by the accounts payable clerk. However, it was decided that preventing the mismatches is a better option. The To – Be process was designed and Ford instituted a process called “invoice-less processing.” Here the purchasing department would enter information into an online database as soon as an order is initiated. In the To-Be process, the copy of the purchase order would no longer be sent to anyone. As soon as the goods arrive at the receiving dock, the receiver clerk would check the online database and match if the received goods correspond to any outstanding purchase order. If it matches, the clerk would accept the consignment and would enter the transaction into the database. However, in case of a mismatch, i.e., if there is no corresponding database entry existing for the received goods, then the clerk would return the order.

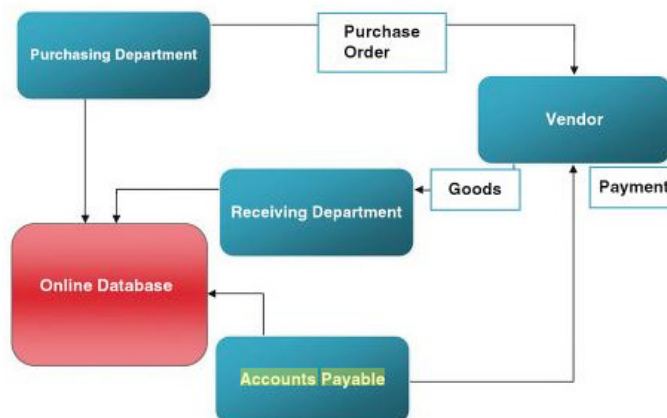



The To- Be process would require matching of three items, namely, the part number, supplier code, and unit of measure, between the receipt record and the purchase order. The matching would be done automatically and the check would be prepared by the IT system and the accounts payable department would send the check to the vendor. Ford Motor company would request its vendors not to send any invoices, so that all the time and cost incurred on matching could be removed and an invoices-less process could be launched.

Ford implemented the To- Be process and thus achieved a head count reduction of 75%, as compared to the 20% that it would have achieved through a conventional process improvement. The new process would also ensure data consistency across all the departments, as all of them would be using the same online database

### **Case 2: IBM Credit Co. reengineering its credit approval process (adapted from Hammer & Champy, 1993)**

IBM Credit Corporation is in the business of financing the computers, software, and services that the IBM Corporation sells. The IBM Credit's operation comprises of five steps as follows:

- (1)** When an IBM field sales representative called in with a request for financing, one of the operators in the central office wrote down the request on a piece of paper.
- (2)** The request was then dispatched to the credit department where a specialist checked the potential borrower's creditworthiness, wrote the result on the piece of paper and dispatched to the next link in the chain, which was the business practices department.
- (3)** The business practices department was in charge of modifying the standard loan covenant in response to customer request. The special terms to the request form would be attached to the request if necessary.
- (4)** Next, the request went to the price department where the appropriate interest rate to charge the customer is determined.
- (5)** Finally, the administration department turned all this information into quote letter that could be delivered to the field sales representative.

This entire process consumed six days on average. From the sales representative's point of view, this turnaround was too long that the customer could be seduced by another computer vendor. Furthermore, no one would tell where the request was and when it could be done.

To improve this process, IBM Credit tried several fixes. They decided, for instance, to install a control desk, so they could answer the sale representative's question about the status of the request. That is, instead of forwarding the request to the next step in the chain, each department would return the request to the control desk where an administrator logged the completion of each step before sending out the request again. This fix did indeed solve the problem, however, at the expense of adding more time to the turnaround.

Eventually, two senior managers at IBM Credit took a request and walked themselves through all five steps. They found that performing the actual work took in total only ninety minutes. Clearly, the problem did not lie in the tasks and the people performing them, but in the structure of the process itself.

In the end, IBM Credit replaced its specialists - the credit checkers, prices and so on - with generalists. Now, a generalist processes the entire request from beginning to end. But, how could one generalist replace four specialists? The old process design was, in fact, found on a deeply held (but deeply hidden) assumption: that every bid request was unique and difficult to process, thereby requiring the intervention of four highly trained specialists. In fact, this assumption was false; most requests were simple and straightforward: finding a credit rating in a database, plugging numbers into a standard model, pulling clauses from a file. These tasks fall well within the capability of a single individual when he or she is supported by an easy-to-use computer system. IBM Credit therefore developed a new, sophisticated computer to support the generalists. In most situations, the system provides guidance



and data to generalists. In really tough situations, he or she can get help from a small pool of real specialists who are assigned to work in the same team.

The new turnaround becomes four hours instead of six days. The company achieved a dramatic performance breakthrough by making a radical change to the process. IBM Credit did not ask, "How do we improve the calculation of a financing quote? How do we enhance credit checking?" It asked instead, "How do we improve the entire credit issuance process?" And the result was a 90% improvement in cycle time and 100 times (not 100%) increase in productivity (# of deals).

### **Failure of BPR Projects:**

#### **Barriers to effective implementation**

Downsizing and restructuring means doing less with less. Reengineering, in contrast, means doing more with less. It is a refreshing new approach to doing business and there is plenty of evidence that it works well -even spectacularly- at times. Performance gains of 50 to 100 percent are common for some reengineered processes.

However, despite all the energy, money, and efforts spent by companies trying to make their organizations' reengineering efforts successful, reengineering is still an unfulfilled promise. **Hammer & Champy (1993)** estimate (unscientifically) that 70% of organizations that undertake reengineering fail to achieve any results. This is true, not because the concept is flawed, but because of implementation problems. **Attaran (2003)** describes the common barriers to effective implementation of BPR projects as follows:

- **Misunderstanding of the concept:** Lack of understanding the concept cause managers label any organizational change as reengineering which results with a failure to appreciate the promise of reengineering.
- **Misapplication of the term:** Reengineering is not cheap, and it cannot be successful without a continuous improvement process.
- **Lack of proper strategy:** A major reason for the high failure rates of BPR efforts is that the efforts are not connected to the corporate goals.
- **Unrealistic objectives:** Reengineering always takes longer than expected, always involve more people resources than are available, and always presents problems no one anticipates.
- **Management failure to change:** Lack of leadership is a frequent cause for the high failure rate of BPR projects.
- **Failing to recognize the importance of people:** Many companies who attempt reengineering focus on process design and ignore or underestimate the importance of people.
- **IT failure to change:** IT can be one of the greatest barriers to BPR. Many reengineering efforts have been stopped because radical change would require IT redesign. Resistance on the part of IT personnel has more often been a failure in implementation than an enabler.

#### **The Myths about BPR**

Besides the common barriers to effective implementation of BPR described by **Attaran (2003)**, as time passes, some myths concerning the BPR concept also represent obstacles in front of BPR projects. The **seven myths** of BPR described by **Grover & Malhotra (1997)** are as follows:

**Myth 1:** "Reengineering is a radical one-time approach" is changing as many firms are not willing to invest the money and time to implement change from a "clean state".

**Myth 2:** "Reengineering involves breakthrough performance gains" is being challenged as benchmarking and measurement of these gains can prove elusive.

**Myth 3:** “Reengineering enables change primarily through IT” is being moderated by the numerous organizational innovations involving people, jobs, skills and structures that facilitate process-oriented behaviors.

**Myth 4:** “Reengineering should focus on cross-functional core business processes” is fine, but many piecemeal improvements within functions can also add up to significant change and have proven very successful.

**Myth 5:** “Reengineering enhances individual capacities through empowerment and teams” is all well and good but many process-change projects are being defended based on cost objectives achieved through downsizing with few opportunities for retraining.

**Myth 6:** “Reengineering can use a standardized set of methods touted by armies of consultants” is being questioned given that no standardized approach exists to date.

**Myth 7:** “Reengineering must be conducted from the top down” is being challenged since often detailed understanding of process design resides with people who do the work.

The concept of BPR has originated in the early 1990s and has achieved popularity amongst businesses in a very short period of time. Now it is going through its second wave with the great pace of the advent in telecommunications.

### 3.3 VALUE CHAIN ANALYSIS

If each business functions is expected to create a value to the products or services of the firm, we can look at the firm accordingly and make value chain analysis as part of value management approach.

Suppliers and customers are also essential parts of total value chain analysis and hence are included in it.

A value chain is the sequence of business functions in which utility is added to the products or services of the firm. Through proper analysis of each segment of the value chain, customer value is enhanced. No-value creating activities are eliminated.

In value chain analysis, each of the business functions is treated as an essential and value contributor and is constantly analyzed to enhanced value relative to the cost incurred. Like business functions, in value chain approach also, it is important that the efforts of all functions are integrated and co-ordinated to increase the value of the products or services to the customers.

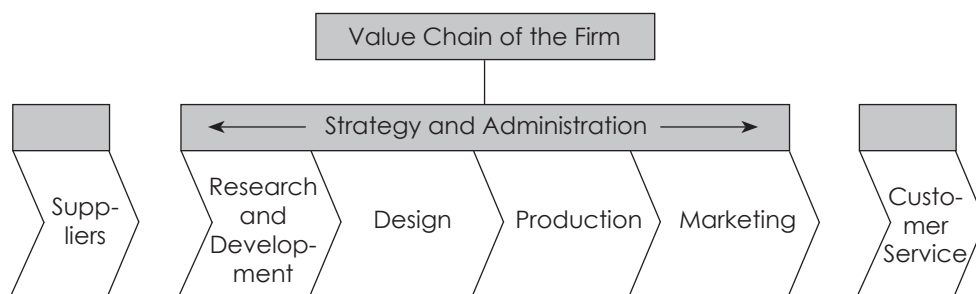

The value chain approach is an integral part of **strategic cost management**, which is an approach to Management Accounting that explicitly highlights **Strategic issues and concerns**. It sets cost analysis as a broader context in which cost information is used to develop superior strategies.

Modern cost accountant has an important role to play in analyzing cost information relating to each of the segments of the value chain and supplying the same to other functional managers for improved decisions.

### 3.3.1 Different views are given below about value chain:

- (i) **Porter's Definition:** Value chain is the series of internal processes or activities a Company performs, "to design, produce, market, deliver and support its products." "A firm's value chain and the way it performs individual activities are a reflection of its history, its strategy, its approach of implementing its strategy, and the underlying economics of the activities themselves."
- (ii) **Definition of John Shank and V.Govindarajan:** "The Value chain for any firm is the value – creating activities all the way from basic raw material sources from component suppliers through to the ultimate end-use product delivered into the final consumers' hands."

### 3.3.2 Industry Value Chain

1. Industry value chain refers to the series of activities, which add value to the product supplied to the industry.
2. It starts with the value creating processes of suppliers, who provide the basic raw materials and components.
3. It continues with the value creating processes of different classes of buyers or end-use consumers, and culminates in the disposal and recycling of materials.

### 3.3.3 Classification of Value Chain Analysis (Porter's View) :

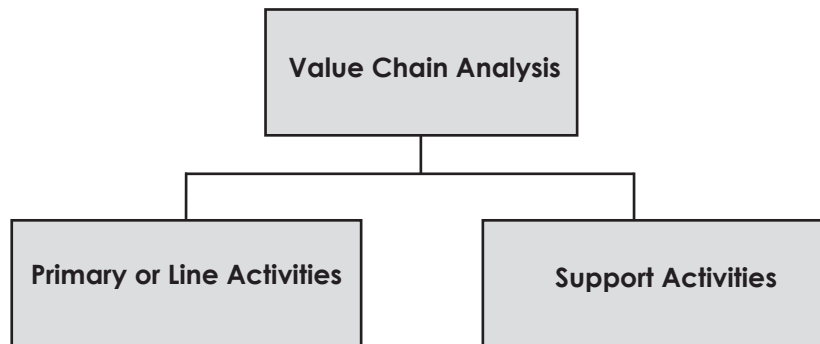

1. **Primary Activities** are directly involved in transforming inputs into outputs and delivery and after – sales support to output. They are handled by line functions in an organisation. They include-
  - a) Material handling and warehousing ;
  - b) Transforming inputs into final product ;
  - c) Order processing and distribution ;
  - d) Communication, pricing and channel management; and
  - e) Installation, Repair and parts replacement.
2. **Support Activities** are activities that support primary activities. They are handled by the organisation's staff functions & include –
  - a) **Procurement** – Purchasing of Raw material, supplies and other consumable items as well as Assets.
  - b) **Technology Development** – Know – how, procedures and Technological inputs needed in every value chain activity.
  - c) **Human Resource Management** – Selection, promotion and placement, appraisal, rewards; management development; and labour/employee relations.
  - d) **Administration** – General management, planning, finance, accounting, legal, government affairs and quality management.

### 3.3.4 Compare and Contrast the source of Competitive Advantage

A firm's overall Competitive Advantage is derived from the difference between Value Offered to Customers and cost of creating that customer value. This competitive advantage takes two possible forms – (i) Differentiation Advantage (ii) Low- cost Advantage. A comparative analysis of these forms is given below –

<b>Differentiation advantage</b>	<b>Low cost advantage</b>
It occurs when customers perceive that a Firm's product is of higher quality and /or outperforms competing products offered by competitors. Customers are thus willing to pay a premium price for this product	A firm enjoys a relatively low – cost advantage if its total costs are lower than the market average.
<b>Gained by-</b> <ol style="list-style-type: none"> <li>1. Ability to deliver goods in a timely manner,</li> <li>2. Better quality</li> <li>3. Provision of after –sales support services</li> <li>4. Offer a wider range of goods and services etc.</li> </ol>	<b>Gained by-</b> <ol style="list-style-type: none"> <li>1. Access to low –cost raw materials;</li> <li>2. Innovative process technology;</li> <li>3. Low –cost access to distribution channels</li> <li>4. Economies of scale,</li> <li>5. Superior operating management etc.</li> </ol>
<b>Can be exploited by-</b> <ol style="list-style-type: none"> <li>1. Increasing prices until it just offsets the improvements in customer benefits thus maintaining current market share; or</li> <li>2. Pricing below the 'full premium' level in order to build market share.</li> </ol>	<b>Can be exploited by-</b> <ol style="list-style-type: none"> <li>1. Pricing the products lower than its competitors' so as to gain market share and maintain current profitability ; or</li> <li>2. Matching with price of competing products and increase its profitability.</li> </ol>
Superior relative differentiation position offers the customers <b>better value for an equivalent price.</b>	Superior relative cost position offers the customers <b>equivalent value for a lower price.</b>

### 3.3.5 VCA can be used to assess Competitive Advantage

A company can gain competitive advantage not just by matching or surpassing its competitors, but discovering what the customers want and then profitably satisfying, and even exceeding, customers' expectations. This is done by concept called Value Chain Analysis (VCA).

VCA can be used to better understand which segments, distribution channels, price points, product differentiation, selling propositions and value chain configurations will yield the Firms the greatest competitive advantage.

To assess competitive advantage by using VCA involves the following analyses –

- Internal cost Analysis-** to determine the sources of differentiation (including the cost) within internal value creating processes; and
- Internal Differentiation Analysis-** to understand the sources of differentiation (including the cost) within internal value creating processes ; and
- Vertical Linkage Analysis –** to understand the relationships and associated costs among external suppliers and customers in order to maximise the value delivered to customers and minimise cost.

**3.3.6 The following actions and steps are involved in the above analyses**

Stage	Description
1.	<p><b>Internal Cost Analysis:</b></p> <ul style="list-style-type: none"> <li>• Identify the firm's value – creating processes.</li> <li>• Determine portion of the total cost of the product or services attributable to each value creating process.</li> <li>• Identify the cost driver for each process.</li> <li>• Identify the links between processes.</li> <li>• Evaluate the opportunities for achieving relative cost advantage.</li> </ul>
2	<p><b>Internal Differentiation Analysis:</b></p> <ul style="list-style-type: none"> <li>• Identify the customers' value –creating processes</li> <li>• Evaluate differentiation strategies for enhancing customer value.</li> <li>• Determine the best sustainable differentiation strategies.</li> </ul>
3	<p><b>Vertical Linkage Analysis:</b></p> <ul style="list-style-type: none"> <li>• Identify the industry's Value chain and assign costs, revenues and assets to value creating processes.</li> <li>• Diagnose the cost drivers for each value creating process.</li> <li>• Evaluate the opportunities for sustainable competitive advantage.</li> </ul>

**3.3.6.1 Features of these Analyses**

- a) **Not Mutually Exclusive:** Firms begin by focusing on their internal operations and gradually widening their focus to consider their competitive position within their industry.
- b) **Continuous:** VCA is a continuous process of gaining competitive advantage, not a one –time affair.
- c) **Part of Strategic Planning:** VCA is process of gathering, evaluating and communicating information for business – making.

### 3.3.6.2 Steps involved in Internal Cost Analysis:

<p><b>1. Identify the Firm's value-creating processes</b></p>	<p>(a) Traditionally, the Firm organizes itself into departments based on cost, revenue, profit and investment centres. These centres are useful for control but are not very useful for identifying value-creating Processes.</p> <p>(b) Adopting a process perspective requires a horizontal view of the Firm, beginning with product inputs and ending with outputs and customers.</p> <p>(c) Processes are structured and measured sets of activities designed to produce a specified output for a particular customer or market.</p> <p>(d) Emphasizing process means focusing not on what work is done but on how work is done within the Firm.</p> <p>(e) Process Structure differs from traditional hierarchical structure and shows how the Firm delivers customer value. Processes lend themselves to such measures as cost, time, and output quality and customer satisfaction.</p>
<p><b>2. Determine the portion of total cost of the product/service attributable to each value creating process:</b></p>	<p>(a) A full-cost approach provides the best estimate of life-cycle costs for evaluating the strategic cost advantage of a Firm's value-creating process.</p> <p>(b) For estimating the full cost of each value-creating activity, full utilisation of the capacity of the activity or its practical capacity is normally used. Facility managers and equipment vendors are useful sources of capacity estimates. When costs vary significantly, firms should seek more information for a more realistic long-term estimate of capacity.</p>
<p><b>3. Identify the cost drivers for each process:</b></p>	<p>(a) By listing Cost Drivers, a Firm can assign priorities among its cost improvement initiatives.</p> <p>(b) In order to determine its relative cost advantage, a Firm should also know the cost factors of its competitors.</p> <p>(c) Multiple Cost Drivers are identified for each value-creating process. These may be classified into – <b>(i) Structural Cost Drivers</b> (covering aspects like Scale, Scope, Learning, Technology, Complexity etc.) any <b>(ii) Executional Cost Drivers</b> (Capacity Utilization, Plant Layout, Product Design, Employee Participation, Supplier and Customer Liaison, etc.)</p>

<p><b>4. Identify the links between processes:</b></p>	<p>(a) Activities within a Value Chain are inter-dependent and hence Firms must identify Value Chain linkages among interdependent activities that may impact their total cost.</p> <p>(b) Cost improvement programs in one Value Chain process may lower or increase costs and/or revenues in other processes. Transfer of goods and services from one Value Chain process to another increases cost eliminating these transfers or costs has an impact on overall costs in the subsequent Chain.</p> <p>(c) Such linkages offer sustainable competitive advantage, because of their subtle, complex and inimitable nature.</p>
<p><b>5. Evaluate the opportunities for achieving relative cost advantage:</b></p>	<p>(a) Using the Value Chain approach, a Company attempts to lower cost and improve efficiency within each value-creating process, e.g. negotiate lower costs of process inputs such as wages or purchases. or evaluate make-or-buy options.</p> <p>(b) Reducing process input costs may consist of measures such as negotiating lower wages, moving production to countries with cheaper labour costs, entering into long term contracts with suppliers at reduced prices, etc. Companies also use buyer-seller partnerships to gain advantages in cost, quality, flexibility, delivery and technology.</p> <p>(c) Using Pareto Analysis, a Company should prioritise its value-creating processes since 20% of value creating processes often account for 80% of Total Costs.</p>

**3.3.6.3 Difference between Structural Cost Drivers and Executional Cost Drivers**

<p><b>Structural Cost Drivers</b></p>	<p><b>Executional Cost Drivers</b></p>
<ul style="list-style-type: none"> <li>• They consist of <b>organizational factors</b> that determine the economic structure driving the cost of Firm's products.</li> </ul>	<ul style="list-style-type: none"> <li>• They capture a Firm's <b>operational decisions</b> of how best to employ its resources to achieve its goal and objectives.</li> </ul>
<ul style="list-style-type: none"> <li>• These cost drivers reflect a Firm's <b>long-term decisions</b>, which position the Firm in its industry and marketplace.</li> </ul>	<ul style="list-style-type: none"> <li>• These Cost Drivers are determined by management policy, style and culture. They are comparatively <b>short-term</b>.</li> </ul>
<ul style="list-style-type: none"> <li>• Structural Cost Drivers <b>may change</b>.</li> </ul>	<ul style="list-style-type: none"> <li>• Executional Cost Drivers <b>may improve</b>.</li> </ul>
<ul style="list-style-type: none"> <li>• <b>Example:</b> Large pharmaceutical companies enjoy economies of scale that lower their unit costs for expensive R &amp; D.</li> </ul>	<ul style="list-style-type: none"> <li>• <b>Example:</b> Worker empowerment and flattened organizations help many Firms in their continuous improvement efforts.</li> </ul>

#### 3.3.6.4 Steps in Internal Differentiation Analysis:

1. Identify the customers' value-creating processes:

To pursue a superior differentiation strategy, a Firm's processes must enhance the value of its customers. Hence, a Firm should carefully study the value-creating processes of its customers.

2. Evaluate differentiation strategies for enhancing customer value:

This involves identification of the value-creating processes that distinguishes a Firm's products or services from those of its competitors. This can be achieved in the following areas -

**(a)** Product Features - that are aesthetically or functionally superior;

**(b)** Marketing Channels - that provide desired levels of responsiveness, convenience, variety and information;

**(c)** Service and Support - tailored to meet end-user and channel member sophistication and urgency of need;

**(d)** Brand / Image Positioning - that lends greater appeal to the Company's products on critical selection criteria;

**(e)** Price - including both net purchase price and cost savings available to the customer through the Financial Services Market.

3. **Determine the best sustainable differentiation strategies:** In order to prioritize its processes as sources of differentiation, a Company must determine what attributes of each process enhance customer value. The more unique a Firm's resources and skills, the more sustainable is its differentiation advantage over competitors

#### 3.3.6.5 Steps in Vertical Linkage Analysis:

Vertical Linkage Analysis is a much broader application of Internal Cost and Differentiation Analysis includes all upstream and downstream value-creating processes throughout the industry. It considers all links from the source of raw materials to the disposal and/or recycling of the product. It involves the following steps -

1. **Identify the industry's Value Chain and assign costs, revenues and assets to value-creating processes:**

(a) The Firm should identify the Vertical Linkages in the industry Value Chain, for example. the petroleum industry consists of numerous value creating processes or activities, including exploration, production, refining, marketing and distribution, which defines its Value Chain.

(b) Costs, Revenues and Assets of each value-creating process may be determined based on relevant cost approach, use of market prices, transfer prices, current replacement cost of assets, etc. The, Information Systems to identify and analyse these subtle relationships should be developed.

2. **Diagnose the Cost Drivers for each value-creating process:**

Different cost determinants should be identified for each value-creating process. Direct labour-based measures or operating hours or other suitable measure may be identified, for each value-creating process.

3. **Evaluate the opportunities for sustainable competitive advantage:**

a. Using benchmarking processes and by understanding how other companies compete in each area of the industry Value Chain, a Firm can use the qualitative analysis to seek out competitive niches, even if financial data are unavailable or unreliable.



- b. To evaluate the opportunities for competitive advantage in the global marketplace, firms need to consider aspects such as a country's values, political climate, environmental concerns, trade relations, tax laws, inflation rates and currency fluctuations.

### **3.3.7 Strategic Framework for Value Chain Analysis:**

- i. Value Chain analysis requires a strategic framework of focus for organising internal and external information, for analysing information, and for summarising findings and recommendations.
- ii. Recent concepts from strategists and organisation experts lead to three strategic framework for VCA-
  - a) Industry structure Analysis
  - b) Core Concepts Analysis; and
  - c) Segment Analysis.

#### **3.3.7.1 Industry Structure Analysis of Michael Porter**

It is a five-factor model to organise information about an industry structure to evaluate its potential attractiveness. Under this model, the profitability of an industry or market - measured by the long-term return on investment of the average Firm -- depends largely on the following five factors that influence profitability.

##### **1. Bargaining Power of Buyers:**

The degree of buyer power generally depends on –

- (a) Customer concentration (higher concentration of customers means greater negotiation leverage);
- (b) Propensity for customers to integrate backward (higher propensity for backward integration & greater bargaining leverage);
- (c) Costs of switching suppliers (lower switching costs means greater leverage for the buyer) and
- (d) Number of alternative suppliers (higher alternatives indicate greater customer leverage).

##### **2. Bargaining Power of Suppliers:**

- (a) Just as powerful buyers can squeeze profits by putting downward pressure on prices, suppliers squeeze profits by increasing input costs. The factors that determine the power of buyers (listed above) determine the power of suppliers.
- (b) The bargaining power of suppliers and buyers relative to the Firm depends on the relationships between their Value Chains.
- (c) Identifying the specific activities involved and the nature of their strengths and relationships can give important insights into the power balance between the buyer and seller, and how it may be altered in the Firm's benefit.

##### **3. Threat of Substitute Products or Services:**

- (a) Profit potential is determined by the maximum price that customers are willing to pay, which in depends on the availability of substitutes.
- (b) Products with few substitutes command higher prices than products with many close substitutes & customer will prefer switching in the latter case.
- (c) A thorough understanding of the Value Chains of buyers as they relate to the Firm's product can help assessing (and combating) the threat of substitution.

#### 4. Threat of New Entrants:

- (a) When an industry is earning a return on invested capital above the cost of capital, that industry will attract more Firms into it. Unless the entry of new Firms is barred, the rate of profit will fall to the competitive level.
- (b) Even the mere threat of entry may be sufficient to ensure that established Firms constrain their prices to the competitive level.

#### 5. Intensity of Competition:

Markets experiencing rapid growth have less intense competition. In such cases, rival companies can usually satisfy profitability and growth without having to take market shares from their competitors (due to increase in Market Size itself).

#### 3.3.7.2 Core Competencies Analysis:

Core Competencies are created by superior integration of technological, physical and human resources. They represent distinctive skills as well as intangible, invisible, intellectual assets and cultural capabilities. Cultural Capabilities refer to the ability to manage change, the ability to learn and team working. Organisations should be viewed as a bundle of a few Core Competencies, each supported by several individual skills.

Core Competence-based diversification reduces risk and investment; and increases the opportunities for transferring learning and best practice across business units.

#### A Core Competence is identified by the following tests -

- (a) **Leverage Test:** Does it provide potential access to a wide variety of markets?
- (b) **Value Enhancement Test:** Does it make a significant contribution to the perceived customer benefits of the end product?
- (c) **Imitability Test:** Can it be imitated? Does it reduce the threat of imitation by competitors?

#### Applying the VCA approach to core competencies for competitive advantage includes the following steps -

##### 1. Validate core competencies in current businesses:

Core Competencies should tie together the portfolio of end products and help a Firm excel in dominating its industry. Core Competencies need to be continually validated, due to continuous technological developments taking place over a period of time.

##### 2. Export or leverage core competencies to the Value Chains of other existing businesses:

The same set of Core Competencies can be exploited in multiple businesses by **exporting** Core Competencies to the Value Chains of other existing businesses.

##### 3. Use Core Competencies to reconfigure the Value Chains of existing businesses:

While Firms may manage their existing Value Chains better than their competitors, sophisticated Firms work harder on using their Core Competencies to reconfigure the Value Chain to improve payoffs. Otherwise, competitors may exploit opportunities.

##### 4. Use core competencies to create new Value Chains:

With strong Core Competencies in its existing businesses, a Firm can seek new customers by developing new Value Chains.

#### 3.3.7.3 Segmentation Analysis.

Industries are sometimes collections of different market segments. Vertically integrated industries are good examples of a string of natural businesses from the source of raw material to end use by the final consumer. Not All Firms in an industry participate in all segments.

Segmentation Analysis will reveal the competitive advantages and disadvantages of different segments. A Firm may use this information to decide whether to exit the segment, to enter a segment, reconfigure one or more segments, or embark on cost reduction differentiation programs.

Using the Value Chain approach for Segmentation Analysis, Grant recommended five steps -

- 1. Identify segmentation variables and categories:** The market may be divided into a number of segments using appropriate bases. Some approaches to define Market segments are-

Based on Customer Characteristics	Based on Product
Geographic	Use – type
Type of organization	Usage
Size of the Firm	Benefits sought
Life style of the customer	Price sensitivity
Age	Competition
Occupation	Brand Loyalty

- 2. Construct a Segmentation Matrix:** After customer and product-related variables have been selected identifying different segments, a Segmentation Matrix can be developed. Two or more dimensions may used to partition an industry. For example, restaurants could be divided into four dimensions; cuisine, price range, type of service (e.g., sit-down, buffet, cafeteria, take--out, fast food) and location.
- 3. Analyze Segment Attractiveness:** Competitive assessments using industry structure analysis or competencies analysis can also be used to evaluate the profitability of different segments. However, competitive focus shifts to an analysis of the different segments. In addition, the interrelationship of segments must be carefully considered.
- 4. Identify Key Success Factors for each segment:** Quality, delivery, customer satisfaction, market share, profitability and return on investment are common measures of corporate success. In this regard, each segment must be assessed using the most appropriate key success factors. Cost and Differentiation advantages should be highlighted by these measures. Examination of differences among segments in buyers' purchase criteria can reveal clear differences in key success factors.
- 5. Analyze attractiveness of Broad versus Narrow Segment Scope:** The competitive advantage of each segment may be identified in terms of low cost and/or differentiation. Sharing the costs across different market segments may provide a competitive advantage. Taking a narrow segment focus may leave a Firm vulnerable to competitors. A segment justifying a unique strategy must be of worthwhile size to support a business strategy.

### 3.3.8 Limitations of Value Chain Analysis

1. <b>Non availability of Data</b>	Internal data on costs, revenues and assets used for Value Chain Analysis are derived from financial report of a single period. For long term strategic decision- making , changes in cost structures, market prices and capital investments etc. may not readily available.
2. <b>Identification of stages</b>	Identifying stages in an industry's value chain is limited by the ability to locate at least one firm that participates in a specific stage. Breaking a value stage into two or more stages when an outside firm does not compete in these stages is strictly judgemental.
3. <b>Ascertainment of costs of Revenues and Assets</b>	Finding the Costs, Revenues and Assets for each value chain activity poses/gives rise to serious difficulties. There is no specific approach and much depends upon trial and error and experiments methods.
4. <b>Identification of cost Drivers</b>	Isolating Cost Drivers for each value creating activity, identifying Value Chain Linkages across activities and computing supplier and customer profit margins present serious challenges.

5. <b>Resistance from employees</b>	Value Chain Analysis is not easily understandable to all employees and hence may face resistance from employees as well as managers.
-------------------------------------	--

### 3.3.9 Role of the Management Accountant in VCA.

The Management Accountant's role will be scant in the following areas-

#### 1. **Need for education, training and awareness:**

Management Accountants should bring the importance of customer value to the forefront of Management's strategic thinking. They should take the initiative to bring the Value Chain message to major players in the Firm through seminars, articles, Value Chain examples and Company-specific applications.

#### 2. **Exploring for information:**

VCA requires expertise in internal operations and information and also remands a great deal of external information. Management Accountants must seek relevant financial and non-financial information from sources outside the Firm.

#### 3. **Creativity:**

Management Accountants must integrate databases and potential sources of timely information on competitive forces confronting the business. This calls for innovation and creativity in gathering and analysing information for management decisions.

#### 4. **System design:**

Designing internal and external information systems to assist managers in planning, monitoring and improving value-creating processes is another challenge of Management Accountants.

#### 5. **Cooperation:**

Management Accountants should solicit support from all senior managers for allocating resources to develop and improve Value Chain-oriented Information Systems. The Management Accountant should ensure that the Top Management is committed to Value Chain Analysis and the organisational changes necessary for its successful implementation.

### 3.3.10 Difference between Traditional Management Accounting and Value Chain Analysis

Particulars	Traditional Management Accounting	Value Chain Analysis
1. Focus	Internal	External
2. Perspective	Seeks cost reduction in "value added" process , i.e. Sale Price less Cost of Raw material	Seeks competitive advantage based on entire set of linked activities from suppliers to end-use customer.
3. Number of cost Driver	Cost is generally based on volume of production and sales	Multiple Cost Drivers are adopted ,i.e. – <ul style="list-style-type: none"> <li>• <b>Structural Drivers</b> (e.g. scale, scope, experience, technology and complexity)</li> <li>• <b>Executorial drivers</b>(e.g. participative management and plant lay out)</li> </ul>
4. Use of cost Driver	Application at the overall firm level (Cost – Volume – Profit analysis)	A set of unique Cost Drivers is used for each value activity.
5. Cost Preferences	Focus on control of manufacturing costs.	Focus on gaining advantage and not only on cost control and cost reduction.
6. Nature of data	Internal Information.	External and internal Information.
7. Benchmarking	Partially present. Inter Firm comparison, if any is generally restricted to financial and not operational information.	Focus on full – fledge benchmarking , " Learning from competitors" , but exploiting one's own strengths to gain advantage.

**CASE STUDY:**

**(1) Value Chain Analysis in Paper Industry**

The value chain framework is a method for breaking down the chain—from basic raw materials to end-use customers—into strategically relevant activities in order to understand the behaviour of costs and the sources of differentiation. A firm is typically only one part of the larger set of activities in the value delivery system. Suppliers not only produce and deliver inputs used in a firm's value activities, but they importantly influence the firm's cost or differentiation position as well. Similarly, distribution channels have a significant impact on firm's value activities.

Therefore, gaining and sustaining a competitive advantage requires that a firm understands the entire value delivery system, not just the portion of the value chain in which it participates. Suppliers and distribution channels have profit margins that are important to identify in understanding a firm's cost or differentiation positioning, because end-use customers ultimately pay for all the profit margins throughout the value chain. Thus, value chain analysis, in contrast to the value added analysis, takes all opportunities for exploiting linkages with firm's suppliers (such opportunities may be dramatically important to the firm) and firm's customers.

The value chain analysis can be explained taking Paper Products Industry as an example (Shank and Govindarajan). This is shown in the following Figure

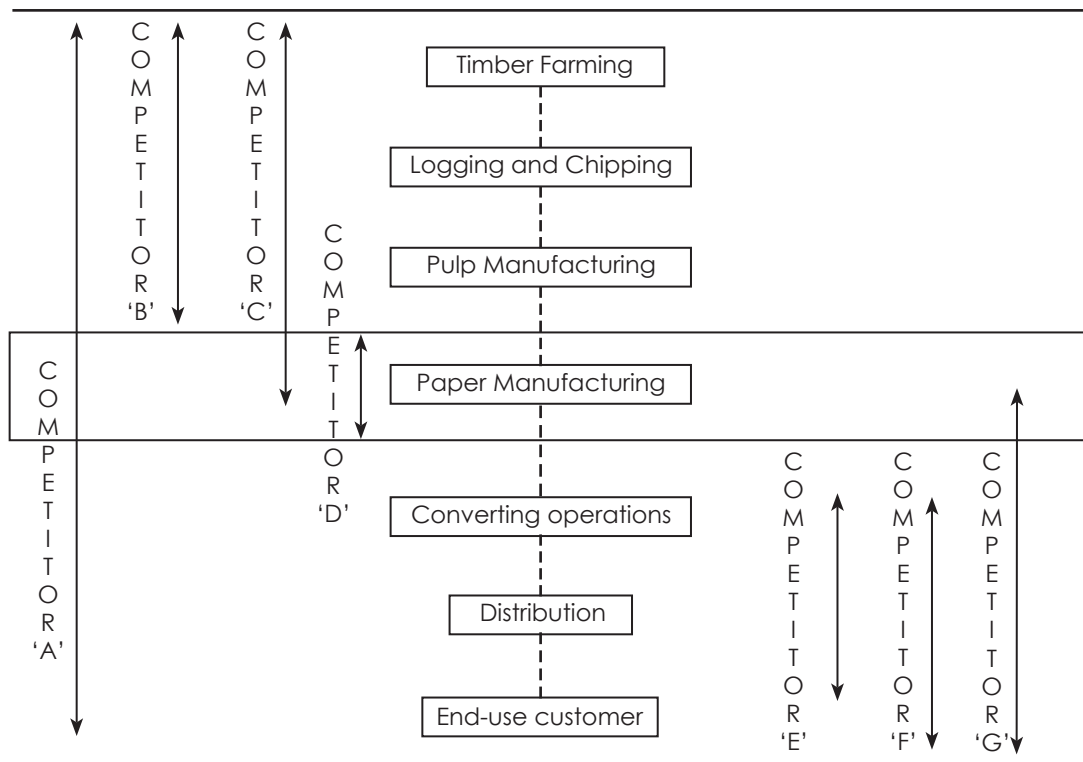

**Fig: Value chain in the Paper Products Industry.**

The distinct value activities (such as timber, logging, pulp mills, paper mills and conversion plants) are the building blocks by which the paper industry creates a product of value to buyers. It is possible to measure the economic value created at each stage by identifying the costs, revenues and assets for each activity. Each firm in the figure must construct a value chain analysis for the total paper industry (with the possibilities to integrate forward or backward in case of firms B, C, D, E, F and G) breaking the

total value in the chain into its fundamental sources of economic value. This has potential strategic implications for every competitor in the paper products industry. These firms must ask strategic questions for value activity relating to:

- make versus buy, and
- forward and backward integration.

They should quantify and assess 'supplier power' and 'buyer power' and exploit linkages with suppliers and buyers.

### **The Methodology**

Porter (1985) explained the steps involved in strategic cost analysis. Shank and Govindarajan (1989) developed them further. In short, it involves the following three major steps:

- define the firm's value chain and assign costs and assets to value activities;
- investigate the cost drivers regulating each value activity; and
- examine possibilities to build sustainable competitive advantage, either through controlling cost drivers or by reconfiguring the value chain.

### **We explain the above steps in somewhat greater detail.**

In identifying the value chain, the main thrust would be to gain competitive advantage, as competitive advantage cannot be meaningfully examined at the level of the industry as a whole. As stated earlier, a value disaggregates the firm into its distinct strategic activities. These activities are the building blocks by which a firm creates a product valuable to buyers. Activities should be isolated and separated if they satisfy any or all of the following conditions:

- (a) They represent a significant percentage of operating costs;
- (b) The cost behaviour of the activities or the cost drivers are different;
- (c) They are performed by competitors in different ways; and
- (d) They have a high potential of being able to create differentiation.

Each value activity incurs costs, generates revenues and ties up assets in the process. After identifying the value chain, operating costs, revenues and assets must be assigned to individual value activities.

The second step is to diagnose the cost drivers (*a cost driver is a cost allocation base*) that explain variations in costs in each value activity. In conventional cost and management accounting, cost is primarily a function of only one cost driver-output volume. In the value chain approach, multiple cost drivers are used for cost allocation and they differ across value activities. Recently, much interest has arisen over activity-based costing (ABC). The *ABC analysis* is largely a framework to operationalize complexity in the system.

The third step relates to developing sustainable competitive advantage about which we have made some observations earlier. Once a firm has identified the industry's value chain and diagnosed the cost drivers of each value activity, sustainable competitive advantage can be gained either by controlling cost drivers or by configuring the value chain. In achieving this goal, the key questions in respect of each value activity would be:

- (a) Can cost in this activity be reduced keeping value (revenue) constant?
- (b) Can value (revenue) be increased in the activity, keeping costs constant?

By scientific analysis of costs, revenues and assets in each activity, the firm can achieve both low cost and differentiation. One way to accomplish this goal is to compare the value chain of the firm with the value chains of one or more of its major competitors and then identify the actions needed to manage the firm's value chain better than their competitors. As we have mentioned earlier, the very process of

performing the value chain analysis can be quite instructive. Such an exercise forces each manager to ask: "How does my activity add value to the customers who use my product (or service)?"

## **(2) Value Chain Analysis in Procter and Gamble Industry**

A study by Dr. Richard Boateng

### **a. Value Chain Analysis of Procter and Gamble**

Value Chain Analysis describes the activities that take place in a business and relates them to an analysis of the competitive strength of the business. Value Chain Analysis is one way of identifying which activities are best undertaken by a business and which are best outsourced. It suggests that the activities of a business could be grouped under two headings: primary activities and supporting activities.

- I. Primary Activities** - those that are directly concerned with creating and delivering a product (e.g. component assembly).

#### **Sourcing and Procurement (sourcing, supply planning, materials procurement)**

Relating this model to P&G's case study, it could be implied that P&G's raw materials are sourced and/or procured from all over the world, wherever it would be cost-effective. It is thus no surprise that for a number of years it had focused on ways to improve supply chain efficiency and costs. It now has a powerful industrial network linking electronically to major suppliers and customers. This is to the extent that it changed companies when efforts to reduce inventory levels only produced marginal improvements. This led to the introduction of agent-based modeling.

#### **Operations (assembly, branch operations)**

P&G's operations had four business units: health and beauty, babies, snacks and beverages, and fabric and home care. It offered more than 300 products including major brands like Tide. It has been aggressively using product lifecycle management software since 2000 for new product development. The company uses Matrix One software for mechanizing and automating the knowledge components, and flow components, within the bringing-a-product-to market phases. In addition, the company is planning to expand its use of agent-based modeling to actually run important aspects of its operations so that end-to-end replenishment cycle for products could be shortened drastically.

#### **Outbound Logistics (warehousing, shipping, fulfillment)**

P&G's largest customer was Wal-Mart that had a reputation for requiring suppliers to coordinate their supply chain processes with its powerful just-in-time continuous inventory replenishment system. A database is used to hold information about work processes vital for creating, reviewing, approving, and distributing products. This enabled the company to lower its costs on items such as pigments and chemicals, and to reduce development time.

#### **Sales and Customer Service (sales, order processing, customer support)**

According to the case study, Wal-Mart was P&G's largest customer, accounting for nearly 20 percent of its sales. Wal-Mart capitalized on this position to force P&G to sell wares to them at the cheapest prices possible. With the coming of a new CEO in 2000, the company began to find new ways of selling its major brands in more flexible, innovative and cost-conscious ways. This was apparently because they were not meeting sales targets, and had to rely on price increase to do so.

- II. Support Activities**, whilst they are not directly involved in production, may increase effectiveness or efficiency (e.g. human resource management). It is rare for a business to undertake all primary and support activities.

#### **Financial Management (financing, planning, investor relations)**

The company's introduction of agent-based modeling saved them \$300 million annually on an investment less than 1 percent of that amount. This is because it was able to perform "what-if" analyses



on inventory levels, in-store stock outs, and transportation costs to find out alternate rules to existing ones being analyzed, such as ordering and shipping frequencies or product allocation in distribution centres. It was discovered that trucks should be often dispatched before fully loaded. Although transportation costs would be higher using partially loaded trucks because of both driver time and fuel to deliver fewer goods, the simulation showed that retail store stock outs would occur less often, thus reducing the amount of lost sales which would make up for the higher distribution costs.

### **Research and Development (product design, testing, process design, material research)**

P&G came to be seen as unimaginative, even stodgy. It seemed weak in developing new products, and had developed just one product in 15 years. This gave the chance for traditional competitors and makers of generic versions of their branded products to grab market share. It established an Intranet called Innovation Net, which was used to bring people together who are working on similar problems in order to generate synergy for new product ideas and product development. Using the same intranet, P&G allows outsiders like research scientists and entrepreneurs to search for new, innovative products worldwide. Further, it uses a very small information technology group called Virtual Learning @ Procter and Gamble to develop the concepts, designs, and packaging for potential new products.

### **Facilities Management (physical plant, IT services, office equipment)**

The case study shows the introduction of several information technology services and systems for the various departments of the company.

1. Matrix One; used to manage and integrate other IT systems and work processes.
2. Innovation Net, and intranet which is used to provide access to published information such as documents, reports, charts and videos.
3. to conduct market research and online surveys
4. Marketing resource management software to enable marketers "focus on creative results-oriented marketing"

### **Human Resource Management (recruiting, training, compensation)**

P&G began to use information systems to support how learning occurred within the company. It created an intranet through which new employees could network with experts, learn from projects and receive answers to pertinent questions. This system encouraged experts to share their knowledge with 'newbies' through an implicit compensation or reward system. Further, human resource was provided with tools they needed to enhance their trade. For example, marketing personnel were given a platform where they could access data, marketing principles and tools in order to make sound judgment about a situation.

### **Marketing and Advertising (market research, promotion, and advertising)**

The company employed the use of knowledge systems to manage marketing. It also uses a very small information technology group called Virtual Learning @ Procter and Gamble to develop the marketing for potential new products. Further, it works with marketing company called Cre8 to put together virtual presentations that demonstrate new concepts to rapidly prototype new features for current products, and even test how consumers react to alternative shelf-space designs. Using information technology in marketing had been ignored in the past because they saw it as complex. P&G's various brands, product lines, customers, and even different marketing groups each used their own independent software for some functions, including email and marketing campaign management. Currently, using z Telligence, P&G does much of its market research and surveying online.

### **Analysis of Procter and Gamble's Business Strategy using the Competitive Forces Model**

Numerous economic studies have affirmed that different industries can sustain different levels of profitability; part of this difference is explained by industry structure. Therefore to have a standard of measuring a firm's competitive urge, Michael Porter provided the Competitive Forces or Five Forces



framework that models an industry as being influenced by five forces. The strategic business manager seeking to develop an edge over rival firms can use this model to better understand the industry context in which the firm operates. The model (as could be deduced from its name) has five parameters called forces.

The first force in this model is **Entry of competitors**. The force describes how easy or difficult it is for new entrants to start competing, and which barriers do exist. P&G have established themselves over the past 166 years as an industry giant in consumer goods. Further, they have more than 300 products. This makes them well-positioned to ward off competition. They could even afford to buy out new start-ups into the industry. Therefore the barriers which exist for such start-ups is how they market their products to beat prices and quality of an industry giant like P&G which does \$40 billion in sales, and is investing in marketing resource development software on a continuous basis.

**Threat of substitutes** in the model refers to how easy a product or service can be substituted, especially if they are cheaper. It could be seen from the case that P&G faced some threat from their traditional competitors such as Kimberly Clark and Colgate Palmolive which had comparable branded products. Obviously, they were gradually taking away some market share~ To add to P&G's woes, makers of generic versions of soap, laundry detergent and toilet paper were selling their products for much less than their established brands. With the existence of cheaper local substitutes, the 'masses' were likely to patronize those ahead of the branded ones.

**Power of buyers:** In addition to the above, it is clear from the case that Wal-Mart had a very important position in the life of P&G. Wal-Mart accounted for nearly 20 percent of P&G's sales (\$40bn) and could be responsible for one-third of global sales in future. This is a whooping sum which could keep increasing if the relationship is harnessed and further explained. However, P&G's earnings are threatened because they have to beat down the prices at which they sell to Wal-Mart. They have not yet discovered any alternative to Wal-Mart and so they have to succumb to their pressure and yield to their demands. On the other hand, they could use this positively especially as Wal-Mart shops are easily accessible (even online) and would thus sell faster which will mean more production – more sales and sustainable profits over time, instead of big profits that could be short-lived.

**Bargaining power of suppliers** in the model is explained by the strength of the position of sellers; whether many potential suppliers exist or there is a monopoly because there are few potential suppliers. P&G according to the case seems to be a manufacturing company of consumer goods. They do their own research and development into new products. With over 300 products, and a new CEO who embarked on a plan to sell its major brands in a flexible, innovative and cost-conscious ways, it is likely they would look for alternative sources of raw materials. This is supported on the basis that P&G has many global brands.

**Rivalry among the existing players** considers whether there is a strong competition between the existing players in the industry. It also seeks to answer the question "is one player very dominant or all equal in strength and size". It may go without saying that, there are several companies which have brands comparable to that of P&G however the latter's are very well marketed and managed, hence popularly established with consumers. With their wide distribution and earnings, it is easier to beat players by slightly reducing prices and/or creating product bundles which would give buyers real value for their purchases.

**What is the role of knowledge management in supporting P&G's business strategy? Explain how knowledge management systems help P&G execute its business strategy.**

P&G uses the codification method in managing learning and knowledge. This could be seen from its use of AskMe Enterprise knowledge network software in addition to an intranet which is used to bring people together who are working on similar problems in order to general synergy for new product ideas and product development. AskMe allowed the addition of qualified experts to the pool of information resources on the intranet. The system, based on the amount of involvement of particular workers in certain subjects, creates a directory of subject-matter experts who can be called on to give advice or



to solve a problem. These experts are rewarded to provide such answers which could be referred to when a similar situation arises.

This removes the need for personal one-on-one training, but rather encourages new employees to learn on their own and become experts themselves later on in their careers. Rewards for answering questions would also encourage experts to share knowledge, ensuring that knowledge is shared, making the company grow. Furthermore, the marketing department lacked adequate information for a marketing campaign. This was solved by using a single software system that covers all of P&G's marketing to support all activities from strategic planning to research, and events.

### 3.4 ACTIVITY, PORTER'S VALUE CHAIN MANAGEMENT EVALUATION AND PERFORMANCE ANALYSIS OF STRATEGIC DECISIONS EXECUTED THROUGH

#### 3.4.1 Target Costing

Businesses have a number of objectives, including satisfying customers with high-quality goods and services, quickly and on time; achieving high levels of market penetration; providing a good working environment for employees; and being financially successful. The long-term financial success of any business depends on whether its prices exceed its costs by enough to finance growth, provide for reinvestment, and yield a satisfactory return to its stakeholders. If there are few competitors, and if demand exceeds supply, it may be possible to simply mark up costs to establish a price that yields a sufficient profit. However, as competition increases, and supply exceeds demand, market forces influence prices significantly more. To achieve a sufficient margin over its costs, a company must manage those costs relative to the prices the market allows or the price the firm sets to achieve certain market penetration objectives. In the context of these characteristics, the practice of target costing has evolved.

According to the CIMA Official Terminology a target cost is 'a product cost estimate derived by subtracting a desired profit margin from a competitive market price.'

Target costing is a technique which developed in the early 1970s in Japan's manufacturing industry. Consumers' demand for more diversified products and shorter product life cycles made the development and planning stages of new products more important. At the same time increased automation and decreased labour costs made standard costing less important as the main method of cost management within manufacturing companies. It was also recognised that the major part of product cost (around 80%) is determined at the design stage and that cost management needed to start earlier in the process. Sakurai (1989) defines target costing as a 'cost management tool for reducing the overall cost of a product over its entire life cycle with the help of the production, engineering, R&D, marketing, and accounting departments'. The use of target costing spread as increased competition, and shorter life cycles, in global markets meant that companies needed to manage costs from the design stage forward, and launch products at prices to attract customers and forestall imitation. Target costing as a technique to achieve these aims spread into other countries and industries.

**Target Costing and the Product Development Cycle**

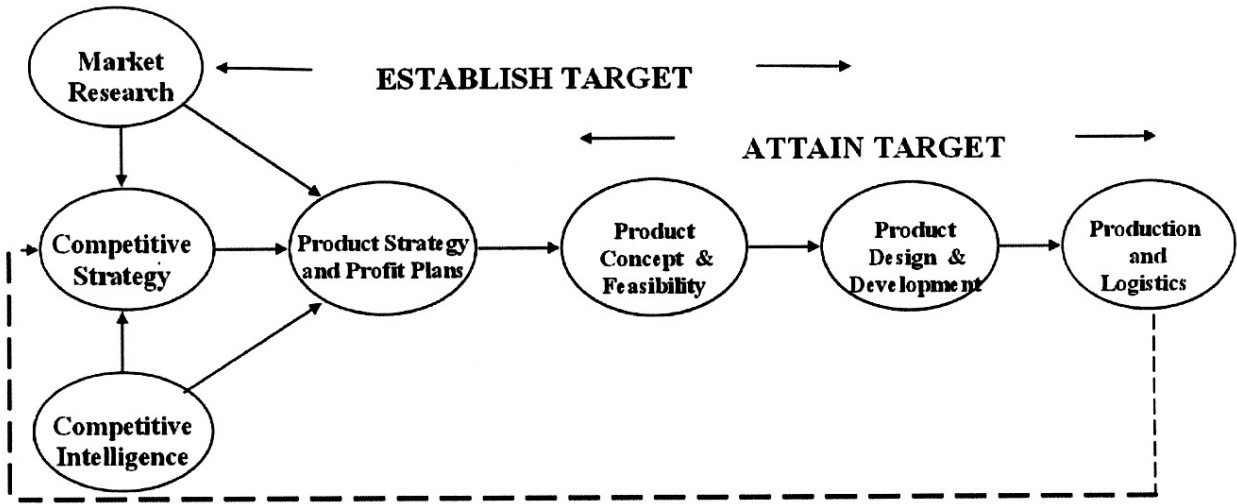

**The Establishment Phase of Target Costs**

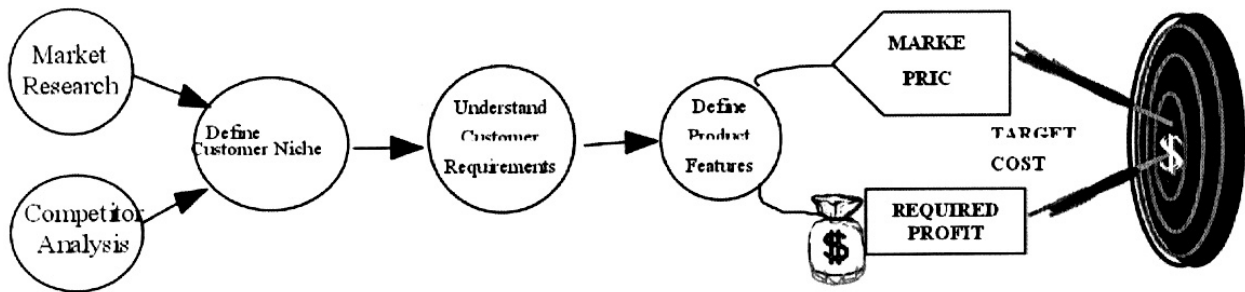

**The Attainment Phase of Target Costs**

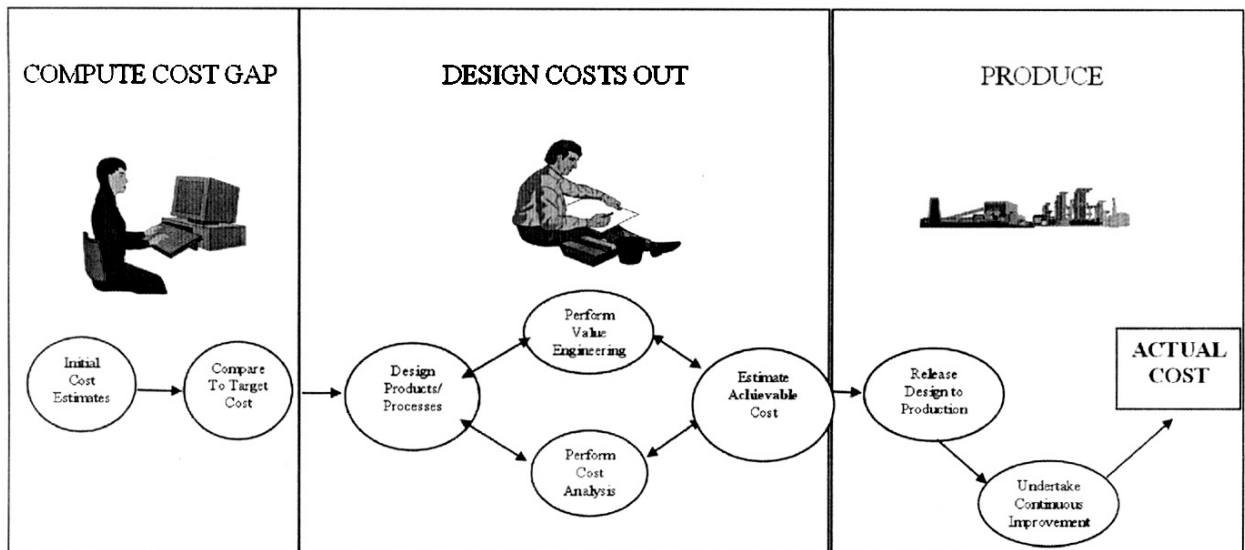

## The target costing process

Historically, target costing has been developed and used in manufacturing companies. There are a number of stages in the process of target costing, as described by Gagne and Discenza (1995) :

1. Establish a selling price for the new product and estimated sales volume from an analysis of the market, and a target profit.
2. Determine the target cost by subtracting the profit from the selling price.
3. Perform functional cost analysis for individual components and processes.
4. Determine the estimated cost for the product.
5. Compare estimate with target.
6. If estimated cost exceeds target cost, repeat cost analysis/value engineering to reduce estimated cost (an iterative process).
7. Make the final decision whether or not to introduce the product once cost estimate is on target.
8. Manage costs during production of the product.

## Determining estimated costs

Once an overall target cost has been established for the product, it is necessary to identify the gap between the target cost and the estimate of the cost to build the product based on current processes, suppliers, productivity levels and materials. The gap gives an estimate of the excess cost which must be taken out of the new product (Cooper and Chew, 1996)

## Achieving target costs

Once the gap has been identified between the target cost and the cost estimate, it is necessary to identify ways to close the gap. Target, or allowable, costs are identified for individual components or processes and cost improvement teams work to reduce the estimated costs to meet the target. However, cost-reduction requirements are not usually applied uniformly across all the components and subsystems of the product, but based on an informed assessment of how much cost can be removed from each component based on value to the customer, historical trends and other data. There may also be a process of negotiation between different production departments and between the company and its supplier to arrive at final target costs for the individual components. This process of cost reduction is an iterative one which continues until the target cost is reached or it is concluded that the overall target cost can not be reached and a decision is made not to launch the product.

Target costing obviously applies to new products. It also applies to product modifications or succeeding generations of products. NEC, for example, uses the point of time at which no further cost reductions can be realized as a cue to begin developing its next generation of products. The foundations of target costing—market-based prices, price-based costs, and cross-functional participation—may also be used for existing products, although costs are more difficult to reduce once a product is in production. The costs most typically emphasized in the target costing process are those most directly affected by it: material and purchased parts, conversion costs (such as labor and identifiable overhead expenses), tooling costs, development expenses, and depreciation. However, because target costing is a comprehensive cost planning, management, and reduction process, as well as a specific technique, all costs and assets that may be affected by early product planning decisions should be considered. This would include more indirect overhead expenses through the production stage, and beyond, such as service costs, and assets, such as inventory. Target costing is intended to get managers thinking ahead and comprehensively about the cost and other implications of the decisions they made.

### 3.4.1.1 Advantages of Target Costing

Obviously a primary reason why companies use target costing is to plan or project the costs of products before they are introduced, and to ensure that low-margin products are not introduced which do not

bring sufficient returns. There are, however, additional purposes for which companies have introduced target costing which vary from company to company. A number of other reasons are as outlined below.

**To reduce costs before they are locked in**

As previously mentioned, it is being increasingly recognised that the major proportion of product costs, around 70 to 80% (Cooper and Chew, 1996) are effectively fixed during the design stage. Target costing provides a means to manage costs from the design stage to maximise the potential for cost reduction.

**To control design specifications and production techniques**

Target costing is a tool which can be used to control decisions such as design specifications and production techniques. For this reason it tends to be oriented more towards management and engineering than accounting, and to be successful requires the use of cost engineering techniques such as value engineering (Sakurai, 1989)

**As an analysis which highlights other problems**

The discipline of target costing and the detailed review of costs can reveal more general managerial problems. For example, Chen and Chung (2002) cite a company which uncovered corrupt practices in the purchasing department as a result of the detailed examination of component prices.

**As a driver for cost improvement**

As already discussed, target costing was originally introduced into Japanese companies as a way to integrate the use of other tools such as JIT and TQC (total quality control) and promote their use (Sakurai, 1989).

**To encourage a focus on the customer**

Target costing is, by nature, market-driven. It therefore stimulates behaviour which is customer-focused and encourages all functions within the company to respond to market demand and competitive trends rather than internal performance indicators. In addition the marketing department is free to make product decisions without the costs being a given (Gagne and Discenza, 1995).

**3.4.1.2 Objectives of Target Costing**

The fundamental objective of target costing is very straightforward. It is to enable management to manage the business to be profitable in a very competitive marketplace. In effect, target costing is a proactive cost planning, cost management, and cost reduction practice whereby costs are planned and managed out of a product and business early in the design and development cycle, rather than during the latter stages of product development and production.

Target costing obviously applies to new products. It also applies to product modifications or succeeding generations of products. The foundations of target costing—market-based prices, price-based costs, and cross-functional participation—may also be used for existing products, although costs are more difficult to reduce once a product is in production.

The costs most typically emphasized in the target costing process are those most directly affected by it: material and purchased parts, conversion costs (such as labor and identifiable overhead expenses), tooling costs, development expenses, and depreciation. However, because target costing is a comprehensive cost planning, management, and reduction process, as well as a specific technique, all costs and assets that may be affected by early product planning decisions should be considered. This would include more indirect overhead expenses through the production stage, and beyond, such as service costs, and assets, such as inventory. Target costing is intended to get managers thinking ahead and comprehensively about the cost and other implications of the decisions they made.

Although the initial emphasis of target costing may be cost planning, management, and reduction, a number of other benefits result from its application. First, it requires a strong market and customer orientation. Product requirements are defined by market and customer needs, and competition.



Target costing starts with an understanding of the market and an intent to meet customer needs in terms of product features, quality, timeliness, and price.

Second, the cross-functional participation central to the process yields a sense of understanding and teamwork frequently absent in a more typical, sequential design and development process. Market-oriented design and development, and concurrent engineering and manufacturing, are aspects of the target costing process that facilitate cross-functional understanding.

Finally, the market understanding, cross-functional team participation, and use of some of the underlying tools (such as value engineering) can actually accelerate the product design, development, production, and introduction cycle by avoiding delays resulting from recycling, as one area's functional objectives conflict with others.

Target costing is as much a significant business philosophy as it is a process to plan, manage, and reduce costs. It emphasizes understanding the markets and competition; it focuses on customer requirements in terms of quality, functions, and delivery, as well as price; it recognizes the necessity to balance the trade-offs across the organization, and establishes teams to address them early in the development cycle; and it has, at its core, the fundamental objective to make money, to be able to reinvest, grow, and increase value.

### **The Role Of The Management Accountant**

The role of the management accountant in some companies (such as Boeing, Caterpillar, General Electric, Ford, Merck, Motorola, and Northern Telecom) is changing from historian, controller, and, often, nay-sayer to a more proactive, strategic, business partner and decision maker. Active involvement in target costing reinforces this shift in perspective and responsibility for the management accountant.

Target costing cannot be undertaken without the full support of senior management and the support and involvement of the other areas of the business, including marketing, product development, procurement, process development, and manufacturing. Once that support has been obtained, management accountants should be committed to the firm's target costing process.

Since management accountants are trained in gathering, analyzing, measuring, and reporting information, their expertise is a fundamental element to a successful target costing effort. Having management accountants involved in the target costing process also gives credibility to the financial implications of the various trade-offs and decisions made during the target costing process. Thus, the management accountant can be responsible for holding the whole process together. Management accountants should be involved in all stages of the target costing process.

The first step in the target costing process is to establish the target price. This involves assessing the market and individual customers' wants and/or needs, and what they might pay for the tentative new product; evaluating competing products, their prices, and estimated costs; and agreeing among the team members as to an appropriate target price. Evaluating customers' benefit/cost trade-offs and performing competitive price and cost comparisons are central financial analyses management accountants are qualified to perform. Companies such as Caterpillar have performed detailed cost analyses of their competitors' products. If management's pricing strategy is "preemptive"—that is, to lower prices to gain additional market penetration—the management accountant is also able to analyze the price, volume, cost, and profit relationships of such actions.

The second step in the target costing process is to establish the target profit margin. The starting point is the firm's overall strategic and financial goals, including return on sales (ROS), capital, and equity. These need to be disaggregated to product lines, and eventually to individual products. Not all product lines or products will have the same target margins. Some will have to be higher to support a higher level of investment directed toward those product lines or products; some may be lower because they require lower investment, or competitive prices and costs will not support a higher margin. As with the target price, setting the target margin requires business understanding and financial analysis skills that the management accountant brings to the process.

A very important role of the management accountant is to help determine what the proposed product's current costs would be, assuming similar product specifications and manufacturing processes to those presently used by the firm. Unfortunately, many companies' existing product cost determination (cost accounting) systems do not provide accurate up-to-date information. Direct material costs may be reasonably identified with specific products. Conversion costs, overhead, and even nonmanufacturing costs (such as outbound freight and product-specific sales costs) may be more difficult to identify with specific products. More companies are using activity-based costing (ABC) to improve their understanding of their existing costs. The management accountant has an important responsibility to introduce ABC to the firm and apply it to the firm's existing products and detailed processes, so a foundation for target costing can be established.

Once the allowable cost has been established and the current cost determined, the amount of cost reductions can be calculated. The target costing team's work really begins at this point, as it considers the possible trade-offs and makes the numerous decisions necessary to deliver a product that meets the markets' requirements at a price and a cost that achieves the firm's profit objectives. The myriad of design alternatives, buy versus make decisions, proposed manufacturing processes, and capital investment requirements all have cost implications that must be calculated, then tracked, separately and collectively. Management accountants assume a central role in this analysis and tracking process.

An important role for the management accountant is to create a systematic framework of financial and nonfinancial measures to assure that, as the target costing process unfolds, progress against the targets may be easily tracked, to make sure the targeted objectives are being reached. Such tracking systems are especially critical if many new products are being introduced and their significance on the firm's financial performance is great. Individual project costs, the cost impact of asset requirements, the ability to achieve the target cost and profit, and cash flows must all be tracked. In the case of multiple projects, their aggregate impact on the firm's overall profit, return, and cash should also be monitored.

Once a product reaches the production stage and it is being sold, there are still opportunities for the management accountant to contribute to the target costing process. First, actual costs should be tracked and related to allowable costs to determine whether allowable costs are being met. This information can be used in future target costing projects. Second, there may be more cost reduction opportunities to be achieved in the production phase. The Japanese call such initiatives to continue to pursue cost reductions during production "kaizen costing" or "continuous improvement costing."

Management accountants can and should play a number of important roles in the target costing process. They can become familiar with the process, talk with other management accountants who are already involved, visit companies already using target costing, and then take the lead in introducing target costing into their firms. This can include sharing their knowledge of target costing with senior management and other functional areas of the firm. Management accountants can champion the initiation of a target costing project. Then they can be an active part of a cross-functional target costing team, contributing their financial analysis skills to the effort. As target costing takes effect, the management accountant will have made another significant contribution to the long-term success of the firm.

#### 3.4.1.3 Principles

There are **six key principles** in target costing:

1. Price – led costing (i.e target price less desired mark-up = target costs);
2. Customer focus;
3. Focus on design of products and processes;
4. Cross- functional teams;
5. Life cycle cost reduction; and

## 6. Value chain involvement.

One has to start from the market and then work back finally to the production process through design and development of product (or the service) that the customer needs at an acceptable price (known as the target price). Target Costing is applied in the design and developing stages. In other words, target costing is effective in managing costs in the new product design and development.

Target costing thus helps control costs before they are locked – in or designed in (i.e., in the design stage). On the other hand, traditional costing methods of cost control focus on controlling costs while they are being incurred (e.g., variance analysis). Target costing is widely used by Japanese and American industries in automobiles (e.g., Toyota, Nissan), electronics (e.g., Panasonic, Sharp, etc), information technology (e.g., Apple, Compaq, etc) and many other areas.

Target Costs are derived from target selling price as follows:

**Target costs of a product (or service) = Target selling price less target profits.**

Using the formula, a firm can calculate backward from a product's selling price to arrive at target costs that the engineers' design cannot surpass. Target costs thus become goals for designers and production personnel. Target costs are standard costs but the significance of target costing is how those standards are developed. Target costs are market- driven standards. The following four steps are generally followed in determining and achieving target costs:

1. Design and develop a product that customers desire.
2. Determine the target price of the product based on customers' perceived value for it and competitive market prices.
3. Determine the desired (or target) profit margin.
4. Derive target costs by deducting desired margin from target selling price.
5. Perform value engineering to achieve target costs.

Value engineering is key to achieving target costs. It is the systematic evaluation of all aspects of production and marketing that starts from research and development, design of products, and ends with distribution of products to the customers and the customer service. Thus, it covers the entire value chain or business functions of a firm. Value engineering needs cooperation across different business functions. Otherwise, target costs cannot be achieved.

### 3.4.1.4 Kaizen Costing:

It refers to the ongoing continuous improvement program that focuses on the reduction of waste in the production process, thereby further lowering costs below the initial targets specified during the design phase. It is a Japanese term for a number of cost reduction steps that can be used subsequent to issuing a new product design to the factory floor.

#### **Need:**

The initial VE review may not be complete and perfect in all cost aspects. There may be further chances of waste reduction, cost and time reduction and product improvement. Such continuous cost reduction technique is called as Kaizen Costing.

The review of product costs under the target costing methodology is not reserved just for the period up to the completion of design work on a new product. There are always opportunities to control costs after the design phase is completed, though these opportunities are fewer than during the design phase.

#### **Process of Kaizen Costing:**

Activities in Kaizen Costing include elimination of waste in production, assembly, and distribution processes, as well as the elimination of unnecessary work steps in any of these areas. Thus Kaizen



Costing is intended to repeat many of the value engineering steps, continuously and constantly refining the process, thereby eliminating out extra costs at each stage.

#### **Multiple Versions of Products – Continuous Kaizen Costing:**

Multiple improved versions of products can be introduced to meet the challenge of gradually reducing costs and prices. The market price of products continues to drop over time, which forces a Company to use both target and kaizen costing to reduce costs to retain its profit margin.

However, prices eventually drop to the point where margins are reduced, which forces the Company to develop a new product with lower initial costs and for which kaizen costing can again be used to further reduce costs. This pattern may be repeated many times as a Company forces its costs down through successive generations of products.

The exact timing of a switch to a new product is easy to determine well in advance since the returns from kaizen costing follow a trend line of gradually shrinking savings. Since prices also follow a predictable downward track, plotting these two trend lines into the future reveals when a new product version must be ready for production.

#### **3.4.1.5 Target Costing vs. kaizen Costing**

It has been mentioned earlier that Kaizen costing can be used to achieve target costs. We thus make a brief comparison between the two as follows:

1. Target costing is effective in managing costs in design and development stages of value chain while Kaizen is effective in the rest of the value chain areas, i.e., production, marketing, customer service , etc.
2. Target costing is essentially a long–term strategy aimed at bringing in excellence in the organization. Kaizen stands for continuous improvement which is geared to short-term repetitive actions for cost reduction.
3. Kaizen is complementary to target costing to achieve the desired result. Used with target costing, Kaizen helps reduce costs through the entire value chain of the firm.

#### **3.4.1.6 Target costing versus cost-plus pricing**

The basic principle of target costing is that the cost of producing and distributing a product must not exceed: **(competitively realistic selling price minus acceptable profit margin)**. For example, if the product can be sold for ₹20 and a profit margin of ₹7 is required then the manufacturer cannot afford to spend more than ₹13 producing and distributing it. The amount of this required profit is likely to depend on how much capital has been invested in production and distribution facilities for the product. The logic behind target costing is essentially the reverse of the logic in cost-plus pricing. The logical error in cost-plus pricing is the idea that cost can be taken as a “given” and that a required profit margin can be added to arrive at a “fair” selling price.

In reality, the issue is not whether a proposed selling price is “fair” but rather whether it is competitively realistic and strategically appropriate. A price derived on a cost-plus basis takes no account of customers' willingness and ability to pay that price. Customers' incomes, price sensitivity of demand, competitors' prices for comparable products of similar functionality, and the market positioning of the product are all important variables which must be consciously considered as part of a strategic approach to pricing. Yet cost-plus pricing recognizes none of these factors. Target costing, by contrast, provides a means of taking explicit note of these factors and provides a framework for an integrated strategic approach to pricing and cost management. It is worth noting that, while target costing is often thought of as a cost reduction technique, some of its best-known users are companies which operate in high-cost economies such as Japan and Switzerland. This is partly because cost savings in a target costing framework are typically achieved by eliminating non-value-adding cost driver activities (thus reducing overhead costs) and not by reducing the direct materials content or manufacturing quality of the product. This point is explored further below.

## The “target cost gap”

In the example above, it was determined that the cost of producing and selling the product must not exceed ₹13. The next step is to predict the product cost which is likely given the existing product design, supply chain, and distribution channels. If this predicted cost is (for example) ₹15 then there is a “target cost gap” of  $₹15 - ₹13 = ₹2$ . Manufacture and distribution of the product cannot take place unless this target costing gap is “closed” by identifying sufficient cost savings. At this stage two points should be made. First, the target costing gap must be closed in full, otherwise the product must not be produced. It might be tempting to say that cost savings of (say) ₹1.50 would be “good enough” but that would be a mistake because it would mean that the minimum required rate of return on the investment would not be achieved. Second, opportunities for closing the target cost gap are typically greatest when the product is still at the design stage of its product lifecycle, is undergoing a fundamental redesign, or where major changes to the supply chain and/or distribution channels are being contemplated. The reason for this is that it is in these situations that there is maximum flexibility to make the changes necessary in order to achieve cost savings.

### Closing the target cost gap by reducing direct costs

One way to close a target cost gap is to reduce direct costs of the product (i.e., direct materials or direct labour). This can best be achieved by elimination of non-value-adding raw materials (such as packaging) or by improving labour productivity (e.g., by investing in training so as to accelerate learning effects). However, care must be exercised if the change involves substituting one type of value-adding raw materials with another.

If the replacement raw material is of obviously inferior quality then the amount which customers would be willing to pay for the product is likely to be reduced, thus cancelling out the profit effects of any cost saving.

However, it is sometimes possible to identify a replacement material which is both cheaper and better for the intended purpose. For example, while customers may prefer natural fabrics such as cotton and wool for major clothing items, synthetic microfibers offer many practical advantages (in terms of durability and cleaning) for smaller items such as socks.

#### 3.4.1.7 Using Activity-Based Cost Management (ABCM) to close the target cost gap

In practice the biggest potential for closing the target costing gap usually lies in applying ABCM so as to achieve savings in overhead costs. This is because ABCM often reveals opportunities for eliminating overhead-causing activities without reducing (and perhaps even increasing) the quality of the product and the customer service experience. Some examples are:

1. The use of common components in several products, so that the total *number (not quantity) of components used in a manufacturing facility is reduced*. Toyota is frequently cited as an example of a company which uses common components across several vehicles. This has delivered savings in supply chain costs (as there are fewer supplier relationships to be managed), manufacturing (since there is a less diverse range of operations to be performed) and quality (because the simplicity reduces failure rates).
2. Reduction in the incidence of cost drivers. For example, by eliminating its central warehouse and insisting that all suppliers deliver directly to each of its stores, a supermarkets chain can reduce the number of transport operations. US retailer Wal-Mart was a pioneer of this practice which is now extremely widespread.
3. To the extent that cost drivers cannot be reduced or eliminated, cost savings can be sought through efficiency improvements or outsourcing. In other words, if the activity cannot be eliminated, can it be done more cheaply?

Target costing is only possible if the organization has in place an Activity-Based Costing (ABC) system. The ABC system provides visibility as to which activities are causing overheads and (by implication) the

extent to which proposed changes are likely to contribute to closing the target cost gap. By contrast, if all overheads are allocated on a direct labour hour (DLH) basis then a manager may try to reduce the labour content of his products so as to be allocated less overhead. However, there will be no saving to the organization in overhead costs, unless DLH is a major activity cost driver.

#### 3.4.1.8 Value analysis in target costing

Value analysis refers to the organizational processes which a firm uses in order to generate the specific ideas for closing the target costing gap. Value analysis involves a “cross-functional team” subjecting a product (including its components, distribution channels, etc.) to detailed scrutiny to determine the relationship between (1) cost, (2) the practical functionality of the product, and (3) the value of the product to the customer. An example of the difference between (2) and (3) is that (2) may be a list of the technical features of a product (not all of which every customer necessarily desires) while (3) refers to each customer’s subjective assessment of what the product is worth to them and therefore what they would be willing to pay for it.

Even a fairly simple change to a product’s design characteristics has implications for (1), (2) and (3). A simple example may a proposal to change the type of battery used in a Smartphone which is being developed. Such a change clearly has implications for the manufacturing cost of the Smartphone, for its technical functionality (e.g., the length of time which the phone can operate without needing to be recharged), and the value of the Smartphone to the customer (e.g., if the battery is unusually heavy than customer value is likely to be adversely affected).

The need for the value analysis team to be cross-functional in its composition arises from the need to understand the relationship between (1), (2) and (3) in assessing design changes. For example, the particular expertise of marketing staff is in understanding what product features is actually willing to pay money for. Production staff understands the practical difficulties of producing products with a particular design. (For example, in manufacturing metal-based products, manufacturing the item in a range of colours – rather than just one standard colour – typically slows down production and increases cost). The accountant’s particular contribution is typically to keep the score – quantifying (insofar as possible) the cost and revenue implications of possible design modifications and assessing the likelihood that they will lead to the closing of the target cost gap.

#### 3.4.1.9 Target costing process tools

Target costing is as much a significant mindset change regarding the relationship of prices and costs, a discipline, and an integrative approach to decision making, as it is the application of a set of techniques and tools. However, a number of techniques and tools facilitate an effective and efficient target costing process.

Three externally-oriented analyses—**market assessment tools, industry and competitive analysis, and reverse engineering**—provide a firm with a foundation for defining the proposed new product and establishing its target price

##### (i) Market assessment tools

The first step in determining the target cost is to assess the market and customers’ wants and needs in regard to the proposed product. A first step to satisfying customers is to find out what they want. This can be accomplished either indirectly (via current or prospective customer surveys) or directly (by using focus groups that bring together groups of current or potential customers to ask them what they like and dislike about existing products, what they want from new products, and what they might be willing to pay for the various product features).

Although getting to know what the customer wants and needs, or may want and need in the future, seems so obvious, many companies do not do it well. Rather, they continue to develop products from an internal perspective. One of the best ways to determine market wants and needs is to ask former customers or noncustomers. These sources can provide insights regarding the shortcomings of existing or proposed products that are very different from the views of existing customers. If satisfied, the company can open up new markets.



Japanese companies have for years made a very strong effort to ascertain customers' needs and their reactions to current products. For example, the Japanese automobile companies have emphasized reliability, fit and finish, quietness of the ride, and little pleasantries such as electric mirrors and drink cup holders to gain market share. North American companies are beginning to do more of that. Prior to the development and introduction of its highly successful Taurus, Ford extensively surveyed existing and prospective customers about what they wanted and did not like in a new car. The Taurus has been one of the most successful cars in the company's history. Boeing builds mock-ups of its cabins and asks its airline customers, and their customers, to evaluate them; Caterpillar puts stereo radios into the cabs of its heavy equipment because that's what operators wanted; Gillette introduced a totally new design for its women's razor; Thermos introduced a highly successful electric grill after extensive market review and evaluation.

### **(ii) Industry and competitive analysis**

A whole body of knowledge has grown, primarily from the work of Michael E. Porter, on the subject of industry and competitive analysis. When companies operate in a near monopoly or oligopoly, understanding one's competitors in detail is less important. However, as the number and strength of competitors increase, understanding those competitors in great depth provides the opportunity to position one's firm and its products to advantage.

A number of leading companies have markedly increased the resources applied toward understanding the industry in which they operate and the competitors with whom they compete. In the late 1970s and early 1980s, Xerox began to realize that they were losing significant market share to a number of Japanese competitors whose product quality was higher and whose prices and costs were significantly lower. Xerox began to learn all they could about these competitors and their products in order to reestablish their market leadership. Similarly, Caterpillar during the early 1980s began to feel the competitive pressures of Komatsu. They assigned a team of executives to specifically study Komatsu.

One conclusion they reached was that Caterpillar's costs were significantly higher because of outdated manufacturing and other practices. That led Caterpillar to refurbish its facilities to markedly reduce their own product costs. General Electric, emanating from its commitment to be "Number One or Number Two" in any industry in which it operates, spends a great deal of its strategic planning efforts understanding its markets and competitors. One of the capstone requirements of GE's Financial Management Training Program (FMP) is for the participants to complete a competitive analysis of one of GE's major competitors. A visit to Honda's motorcycle plant in the early 1980s prompted Harley-Davidson to rethink its whole business approach. Harley-Davidson's turnaround is one of the true success stories of North American manufacturing in the last decade.

### **(iii) Reverse Engineering**

One of the tools that companies such as Xerox, Caterpillar, and the U.S. automobile companies are now using extensively is called reverse engineering or teardown analysis. These companies acquire competitors' products and disassemble them to investigate their design, material, likely manufacturing processes, product quality and attributes, and product costs. In this way, these companies really understand their competitors' products, how they differ from their own, and what they cost to produce. Some might argue that a number of companies have been doing reverse engineering for some time. The difference is the organization and degree to which it is being done by some companies, the resources that are committed to the process, and the pervasive use to which the analysis is put. Leading-edge companies such as Chrysler have built significant teardown facilities, committed sizable resources, and use the results of the analysis across the full spectrum of concept, design, procurement, process engineering, manufacturing, and post-sales activity. Rather than be a tangential exercise, which may or may not be used, in leading-edge companies reverse engineering has become central to a full understanding of the competitors' product and service offerings.

The objective of target costing is to assure that a firm achieves its product-specific and firm-wide profit objectives in a very competitive market environment. It is becoming increasingly essential as more firms

are realizing that they cannot increase prices to solve cost and profit squeeze problems. Target costing requires a major change in mindset for many companies, executives, and management accountants accustomed to operating for so many years in a business environment more accepting of regular price increases. Those industries most clearly affected by increasing global, competitive pressures could be expected to respond most quickly to the approach and benefits of target costing. Those seemingly less immediately affected may fail to react as quickly, and, as a result, may fail to achieve the benefits of earlier cost planning and stricter cost management, and their impact on profitability and market position. Implementing target costing will take time. It requires widespread education, the support of senior management, the involvement of all parts of the organization, and a strong, proactive role on the part of the management accountant.

## CASE STUDY

### Moonglow Electronics Company

The Moonglow Electronics Company a rapidly growing manufacturer of sophisticated electronic equipment for industrial application. Despite the intense competition of the industry, Moonglow has grown to over \$500 million per year in sales.

Several years ago, its management had become impressed with what it read about Japanese management practices including TQM, JIT, and, more recently, cost management. As a result, they made several trips to Japan to try to understand Japanese management practices better. On a recent trip they focused on Japanese finance and accounting practices. This included:

- frequent (six month) budgets with heavy involvement and commitment by line management;
- strategic cost management using target costing and cross-functional teams; and the role of finance in decision support and facilitation as contrasted with a more typical command and control orientation.

#### Figure. Moonglow Electronics Company Cost Management Analysis

- 15 products selected, representing \$113 M or 38% of '93 revenue
- '93 vs '92 cost comparison, for all 15 products:
  - '93 vs '92 cost trend :
    - 10 higher cost
    - 2 even
    - 3 lower cost
- Four of these products were introduced in the last 3 years:

#### Comparison of Average Unit Price/Cost to Development Target

Model	Sales Price			Cost		
	Target	'92 Actual	%	Target	'92 Actual	%
A	24	29	120.8%	16	20	125.0%
A	18	32	177.8%	3	15	500.0%
A	500	600	120.0%	275	440	160.0%
A	3,300	3,700	112.1%	1,350	2,250	166.7%
Weighted Avg.	3,842	4,361	<u>113.5%</u>	1,644	2,725	<u>165.8%</u>
Arithmetic Avg.			<u>132.7%</u>			<u>237.9%</u>

Management concluded that Moonglow Electronics could apply many of the finance and accounting practices that they encountered by visiting Japanese companies.

Moonglow has analyzed the price, cost, and volume history of some of their key products. The company concluded that for a select group of 15 products, representing nearly 40% of sales for one product line, most of the products' costs increased in the past year. Looking more specifically at four products introduced over the last three years, the company found that prices were usually above what they projected by 13%, while own initiative, costs will also be managed down and out of the business in order that market leadership and margins may be maintained. It was felt that three tasks were required to imbed target costing throughout the organization:

- Achieving a thorough understanding and agreement of the company's current cost management deficiencies;
- Gaining agreement as to what needed to be realized to make target costing a way of life.
- Developing the specific steps that would need to be taken to get there.

**Figure. Moonglow electronics company Air purifier system Price-cost-volume-history**

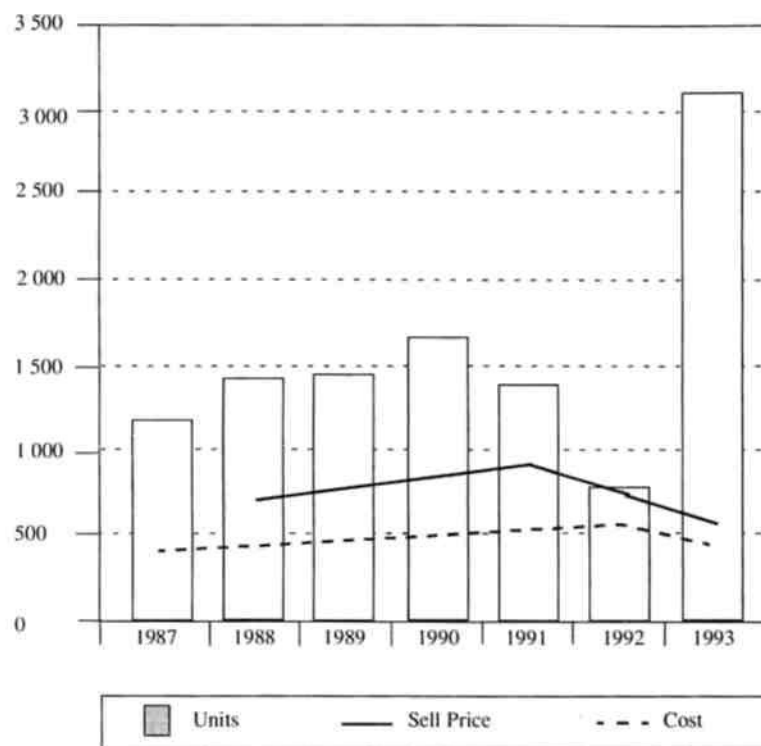

Moonglow financial management concluded that, when compared with leading Japanese companies visited, there was an inadequate concern for cost management and reduction throughout the company. Growth, price increases, and a history of strong profits masked the need for more rigorous cost management. It was concluded that a significant change in mindset would have to be affected whereby cost reduction would become a way of life throughout the company—virtually an obsession for the Moonglow people.

The second major conclusion that was reached was that cost management during design was not a priority; rather, most attention to cost issues occurred after products reached production. More attention to costs during design would be required and appropriate training and tools would need to be provided.

Finally, it was concluded that Moonglow's product introduction process, including the consideration of costs, was very sequential. Marketing passed off to Product Development, Product Development passed off to Engineering and Production, Finance got involved late in the development process. More concurrency would have to be achieved.

It was agreed by Moonglow management that cost management would have to receive much greater attention “every step of the way” in the development process. During product planning (marketing), as a part of product definition, the product’s selling price, projected volume, and initial “target” cost would be determined. In concept design, rough cost estimates would be assessed and assigned to component or functional blocks. By general design and prototype development, more rough cost estimates would be made to assess whether the target cost could still be achieved. Similarly, in detail design (drawings and specifications) and manufacturing system design (processes, tooling, etc.) detailed cost estimates would continue to be made to assure that the target cost could be met. During each and every step of the development cycle, cost estimates would be made to assure that the target cost was attainable.

The final step in Moonglow’s plans to increase cost management practices and results was to outline a specific list of action steps. They included:

- Plan price and cost reductions;
- Develop a formal “estimated cost system”;
- Demand “estimated cost reviews” at each step;
- Continue to develop “team” approach to new product development;
- Measure and learn from experience;
- Develop “value engineering” skills and process throughout the organization;
- Use nontraditional targets and measures to manage cost management process improvements.

To demonstrate the importance that the company was beginning to place on target costing, and his support, the CEO wrote in the company’s 1993 Annual Report. “Our financial executives studied the disciplines in use at a number of leading Japanese companies during the past year. As a result we have instituted a *Target Costing* program to formalize our cost reduction efforts.”

#### Illustration 1

The operation costs of a product produced by ABC Ltd are ₹53. Presently, the company produces only 600 units p.a. to sell at ₹55 per unit due to hard competition in the market. But with existing facilities, production can be increased to 1,000 units if additional production can be sold in the market. The company accordingly introduced target costing on market research, new design for the product and changes in the process so that costs are brought down substantially and market share can be increased. The estimates for the next year are:

Target selling price	₹ 50 per unit
Target profit margin	10% on sales
Target volume	900 units

#### Required:

- a) Calculate target costs per unit and target costs for the expected volume; and
- b) Compare existing profit with target profit.

#### Solution:

##### Statement of Target Costs

Particulars	Per Unit (₹)	For 900 units (₹)
Target selling price	50	45,000
<b>Less:</b> Target profit margin (10% of sales)	5	4,500
Target costs	45	40,500



## Comparative Profit Statement

Particulars	Existing Position		Proposed Position	
	Per unit (₹)	600 units (₹)	Per unit (₹)	900 units (₹)
Sales	55	33,000	50	45,000
Less: Costs	53	31,800	45	40,500
Profit	2	1,200	5	4,500

### Illustration 2

A manufacturing company "Bee" sells its product at ₹1,000 per unit. Due to competition, its competitors are likely to reduce price by 15%. Bee wants to respond aggressively by cutting price by 20% and expects that the present volume of 1,50,000 units p.a. will increase to 2,00,000. Bee wants to earn a 10% target profit on sales. Based on a detailed value engineering the comparative position is given below:

Particulars	Existing (₹)	Target (₹)
Direct material cost per unit	400	385
Direct manufacturing labour per unit	55	50
Direct machinery costs per unit	70	60
Direct manufacturing costs per unit	525	495
Manufacturing overheads :		
No. of orders (₹80 per order)	22,500	21,250
Testing hours (₹2 per hour)	4,500,000	3,000,000
Units reworked (₹100 per unit)	12,000	13,000

Manufacturing overheads are allocated using relevant cost drivers. Other operating costs per unit for the expected volume are estimated as follows:

Research and Design	₹50
Marketing and customer service	₹130
	₹180

### Required:

1. Calculate target costs per unit and target costs for the proposed volume showing break up of different elements.
2. Prepare target product profitability statement.

### Solution:

#### (a)

Target selling price : ₹1,000 less 20%	₹ 800
Less: Target profit margin (10%)	₹ 80
Target costs per unit	₹ 720



The break-up of ₹ 720 per unit is as follows:

### Target Costs per unit

Particulars	Per unit (₹)	
Direct materials		385
Direct manufacturing labour		50
Direct machining costs		60
Direct manufacturing costs		495
<b>Add: Manufacturing overheads:</b>		
Ordering and receiving	8.50	
(21,250 x ₹80) ÷ 2,00,000		
Testing and inspection	30.00	
(30,00,000 x ₹2) ÷ 2,00,000		
Rework	6.50	
(13,000 x ₹100) ÷ 2,00,000		45
Total manufacturing costs		540
Other operating costs:		
Research and Design	50	
Marketing and Customer service	130	180
Full Product Costs		720

### (b) Target Product Profitability

Particulars	Per unit (₹)	2,00,000 units (₹)
1. Sales	800	16,00,00,000
2. Costs of goods sold:		
Direct materials	385	7,70,00,000
Direct labour	50	1,00,00,000
Direct machining costs	60	1,20,00,000
	495	9,90,00,000
Manufacturing overheads	45	90,00,000
	540	10,80,00,000
3. Gross margin (1-2)	260	5,20,00,000
4. Operating costs:		
Research and Design	50	1,00,00,000
Marketing and customer service	130	2,60,00,000
	180	3,60,00,000
5. Operating profit (3-4)	80	1,60,00,000

### 3.4.2 Activity Based Management (ABM)

Activity-Based Management (ABM) manages activities to improve the value of products or services to customers and increase the firm's competitiveness and profitability. ABM draws on ABC as its major source of information and focuses on the efficiency and effectiveness of key business processes and



activities. Using ABM, management can pinpoint avenues for improving operations, reducing costs, or increasing values to customers. By identifying resources spent on customers, products, and activities, ABM improves management's focus on the firm's critical success factors and enhances its competitive advantage.

ABM applications can be classified into two categories: operational ABM and strategic ABM. Operational ABM enhances operation efficiency and asset utilization and lowers costs; its focuses are on doing things right and performing activities more efficiently. Operational ABM applications use management techniques such as activity management, business process reengineering, total quality management, and performance measurement.

Strategic ABM attempts to alter the demand for activities and increase profitability through improved activity efficiency. Strategic ABM focuses on choosing appropriate activities for the operation, eliminating nonessential activities and selecting the most profitable customers. Strategic ABM applications use management techniques such as process design, customer profitability analysis, and value chain analysis.

Some of the key tools of ABC/M are activity analysis, activity-based costing, performance measurement, and several contemporary management techniques: benchmarking, total quality management, business process improvement, and reengineering. Another technique, value-added analysis, is explained here. We take a look now at activity analysis and value-added analysis.

### **Activity Analysis**

To be competitive a firm must assess each of its activities based on its need by the product or customer, its efficiency, and its value content. A firm performs an activity for one of the following reasons:

- It is required to meet the specification of the product or service or satisfy customer demand.
- It is required to sustain the organization.
- It is deemed beneficial to the firm.

Examples of activities required to sustain the organization are providing plant security and compliance with government regulations. Although these activities have no direct effect on the product or service or customer satisfaction, they cannot be eliminated. Examples of discretionary activities deemed beneficial to the firm include a holiday party and free coffee.

### **Value-Added Analyses**

Eliminating activities that add little or no value to customers reduces resource consumption and allows the firm to focus on activities that increase customer satisfaction. Knowing the values of activities allows employees to see how work really serves customers and which activities may have little value to the ultimate customers and should be eliminated or reduced.

A high-value-added activity increases significantly the value of the product or service to the customers. Removal of a high-value-added activity decreases perceptively the value of the product or service to the customer. Inserting a flange into a part, pouring molten metal into a mold, and preparing a field for planting are examples of high-value-added activities. Installing software to protect a computer from spam is a high-value-added activity to customers annoyed

by bombardments of unwanted e-mail. Designing, processing, and delivering products and services are high-value-added activities.

For a television news broadcasting company a high-value-added activity is one that, if eliminated, would affect the accuracy and effectiveness of the newscast and decrease viewer satisfaction and ratings for that time slot. An activity that shortens delivery from three to two days is a high-value-added activity. Activities that verify story sources to ensure the story's accuracy are high-value-added activities. Activities to plan newscasts so that viewers can follow transitions from one story to the next are high-value-added activities.

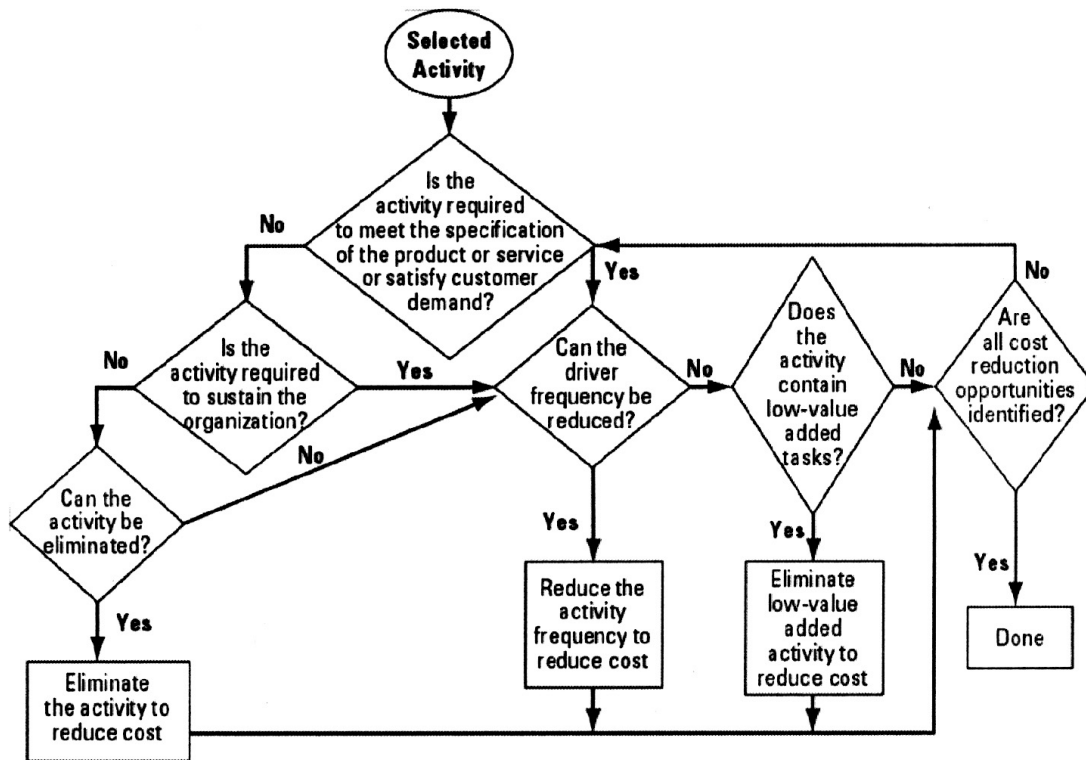

High-value-added activities are those:

- That are necessary or required to meet customer requirements or expectations.
- That enhance purchased materials or components of a product.
- That contribute to customer satisfaction.
- That are critical steps in a business process.
- That are performed to resolve or eliminate quality problems.
- That are performed upon request of a satisfied customer.
- That you would do more of, if time permitted.

A low-value-added activity consumes time, resources, or space, but adds little in satisfying customer needs. If eliminated, customer value or satisfaction decreases imperceptibly or remains unchanged. Moving parts between processes, waiting time, repairing, and rework are examples of low-value-added activities. A low-value-added activity for a television news broadcasting company is one that, if eliminated, would have little or no effect on the accuracy and effectiveness of the newscast; the activity contributes little or nothing to the quest for viewer retention and improved ratings. Activities such as developing stories not used in a newscast or correcting prior stories are examples of low-value-added activities for a television broadcasting company. In fact, many would consider these activities as non-value-added. Inventory, transportation, waiting, and correction are examples of low-value-added activities.

Reduction or elimination of low-value-added activities reduces cost. Low-value-added activities are those that:

- Can be eliminated without affecting the form, fit, or function of the product or service.
- Begin with prefix "re" (such as rework or returned goods).

- Result in waste and add little or no value to the product or service.
- Are performed due to inefficiencies or errors in the process stream.
- Are duplicated in another department or add unnecessary steps to the business process.
- Are performed to monitor quality problems.
- Are performed due to a request of an unhappy or dissatisfied customer.
- Produce an unnecessary or unwanted output.
- If given the option, you would prefer to do less of.

### 3.4.2.1 Activity Based Management Model

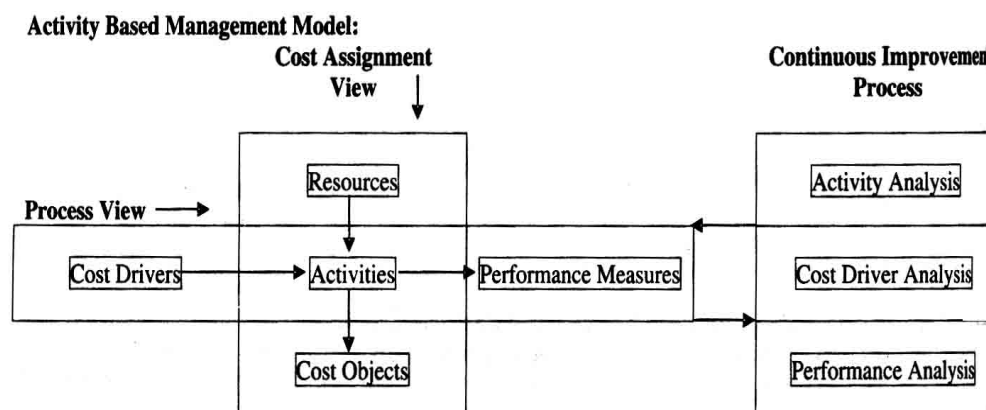

The use of ABC as a costing tool to manage costs at activity level is known as Activity Based Cost Management (ABM). ABM utilizes cost information gathered through ABC.

Through various analyses, ABM manages activities rather than resources. It determines what drives the activities of the firm and how these activities can be improved to increase the profitability.

ABM is a discipline that focusses on the management of activities as the route to improving the value received by the customer and the profit achieved by providing this value. This discipline includes - **(a) Cost Driver Analysis, (b) Activity Analysis, and (c) Performance Analysis**

ABM seeks to satisfy the following customer needs while making fewer demands for resources - (a) Lower Costs, (b) Higher Quality, (c) Faster Response Time, and (d) Greater Innovation.

### 3.4.2.2 Stages in Activity Based Cost Management

Stages	Activities
1	Identification of the activities that have taken place in the Firm.
2	Assigning costs to cost pool for each activity.
3	Spreading of Support Activities costs across the Primary Activities.
4	Determining Cost Driver for each activity.
5	Managing the costs of activities.

### 3.4.2.3 Uses and Benefits of ABM

ABM refers to the entire set of actions that can be taken on a better information basis with activity-based cost information. Organizations implement ABM for different reasons. They believe ABM will help them make better decisions, improve performance, and earn more money on assets deployed. The following Figure shows how the companies can find the value in ABM Information in different situations.

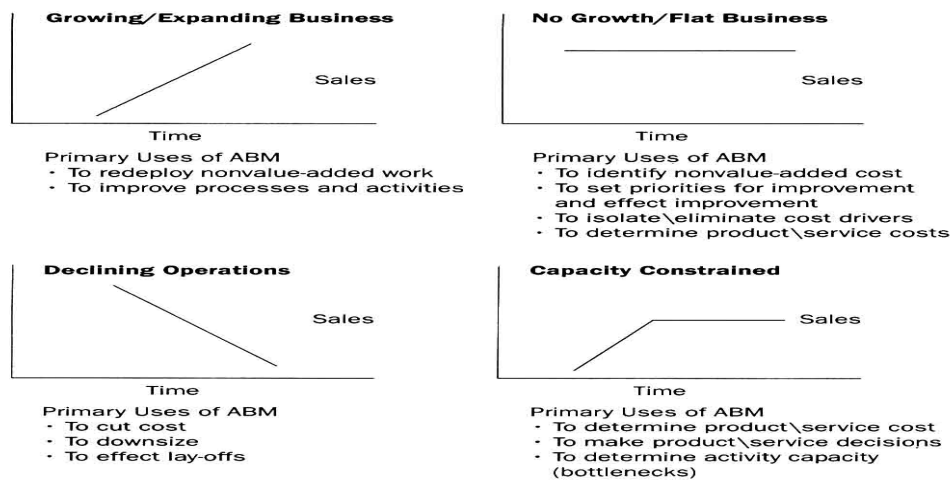

Source: Miller, 1996: 26.

Some of the specific uses of ABM in organizations today include attribute analysis, strategic decision making, benchmarking, operations analysis, profitability/pricing analysis, and process improvement.

**(i) Attribute analysis:** Classifies and combines cost and performance data into manageable, controllable clusters. ABC/ABM systems can use many different attribute or “data tags” for a specific cost. Data attributes allow a company to perform analysis on many different dimensions of a management problem using the same basic warehouse of data. Some common forms of attribute analysis are:

- Value analysis, which utilizes information collected about business processes and examines various attributes of the process (e.g., diversity, capacity, and complexity) to identify candidates for improvement efforts;
- Time variability analysis, which seeks to understand variances in the time needed to complete an activity or provide a service and to develop ways to reduce these variances; and
- Cost of quality, which is a management reporting technique that identifies and measures quality costs within an organization using four basic categories: prevention, detection, internal failure, and external failure.

**(ii) Strategic Analysis:** Explores various ways a company can create and sustain a competitive advantage in the marketplace. Emphasizing longterm objectives and challenges, strategic analysis seeks to impact future costs and improve future profitability by clarifying the cost of various cost objects such as products, customers, and channels. Strategic analysis emphasizes future opportunities and challenges, using a combination of both physical and financial measures to explore the impact of alternative strategic positions. Ways in which ABM supports strategic analysis include:

- Strategic planning;
- Consolidation of operations analysis;
- Acquisition analysis; and
- Analysis of revenue and profitability growth potential.

For example, the ABM initiative at Hewlett-Packard-North American Distribution Organization provides both strategic and operational information including full customer segment costing, full product costing, simple product costing, and targeting of improvement opportunities.

**(iii) Benchmarking:** It is a methodology that identifies an activity as the standard, or benchmark, by which a similar activity will be judged. It is used to assist managers in identifying a process or technique



to increase the effectiveness or efficiency of an activity. ABM supports different types of benchmarking, including:

- Internal benchmarking;
- Industry/competitive benchmarking; and
- Best-in-class benchmarking.

For example, ABM has been successfully applied within AT&T's Business Communications Services (BCS) to support its benchmarking efforts. Unit costs are used as metrics for benchmarking internal work groups as well as comparing the BCS to other billing centers. Work groups that are more cost efficient at performing an activity can share information with other internal groups and billing centers. By having access to reliable cost data, management can investigate cost discrepancies and more effectively plan process improvements to achieve cost reductions.

**(iv) Operations analysis:** It seeks to identify, measure, and improve current performance of key processes and operations within a firm. Areas where ABM is useful include:

- "What-if" analysis;
- Project management;
- Creation and use of activity-based performance measures;
- Capacity management;
- Constraint analysis; and
- Process-based costing.

**(v) Profitability/pricing analysis:** It is a key area for any company. ABM assists a company in analyzing the costs and benefits of products and processes in both the "as is" and post-improvement "to be" scenarios. ABM also supports prelaunch analysis and improvement of product profitability. Areas in which ABM has proven useful in adopting organizations include:

- Product/Service profitability analysis;
- Business process reengineering;
- Distribution channel profitability analysis;
- Market segment profitability analysis; and
- Target and life-cycle costing.

ABM is used in a target costing program at AT&T Paradyne to project future activity and product costs. An ABM target costing process was established for all new and major existing products to facilitate life-cycle cost management. The target costing process begins with specified features and functionality that can be sold to achieve a significant market position. From there, product and manufacturing associate teams interlock on a targeted product cost that is a buildup of material and activity cost.

**(vi) Process Improvement:** It lies at the heart of modern management techniques. Focused on identifying the causes of variation, waste, and inefficiency, process improvement includes both incremental and quantum change efforts that seek to increase the value created per resources consumed by an organization. Uses being made of ABM for process improvement include:

- Business process modeling;
- Total quality initiatives;
- Business process reengineering; and
- Analysis of outsourcing and shared service opportunities.

The Pennzoil Production and Exploration Company (PEPCO) used ABM as a key measurement tool to identify costs by process and to support its reengineering efforts. To keep pace with lower crude and natural gas prices and slowing North American operation, PEPCO needed to find ways to reengineer existing processes to streamline and improve efficiency.

ABM provided the data for PEPCO to change the cost structure of its exploration and production efforts. It achieved this by determining what resources were actually required to support its properties based on current operation. In addition, the reengineering link enabled the company to consider those same properties and determine how it could best meet its economic objectives with fewer resources through a variety of operations improvement analyses.

ABM is used to support a broad array of management initiatives to help organizations create more value for their customers while reducing the cost of operations. Benefits derived from ABM's use include:

- Identification of redundant costs;
- Analysis of value-added and non value-added costs;
- Quantification of the costs of quality by element;
- Identification of customer-focused activities;
- Analysis of the cost of complexity;
- Identification of process costs and support of process analysis;
- Measurement of the impact of reengineering efforts;
- Better understanding of cost drivers;
- Evaluation of manufacturing flexibility investments; and
- Activity-based budgeting.

**3.4.2.4 Distinguish between ABC and ABM.**

ABC	ABM
1. ABC refers to the technique of determining the cost of activities and the cost of output produced by those activities.	It refers to the management philosophy that focusses on the planning, execution and measurement of activities as the key to competitive advantage.
2. The aim of ABC is to generate improved cost data for use in managing a Company's activities.	ABM is a much broader concept and aims to use information given by ABC, for effective business processes and profitability.
3. ABC is the operational segment of ABM.	It is a conceptual aspect, i.e. management attitude.

**3.4.2.5 The Various Analyses under ABM:**

The various analyses under ABM are -

1. **Cost Driver Analysis:** This identifies the factors that cause activities to be performed, in order to manage activity costs. An activity may be performed inefficiently due to a particular reason. Managers have to address this cost driver to correct the root cause of the problem.
2. **Activity Analysis:** It involves identification of the activities of the Firm and the activity centres (or activity cost pools) that should be used in an ABC system. Activity analysis also identifies Value Added (VA) and Non Value Added (NVA) activities. The number of activity centres is likely to change over time, as organizational needs for activity information evolve.
3. **Performance Analysis:** This involves the identification of appropriate measures to report the performance of activity centres or other organizational units, consistent with each unit's goals and objectives. This aims to identify the best ways to measure the performance of factors that are important to organizations, in order to stimulate continuous improvement.

### 3.4.2.6 Business Applications of ABM

1. **Cost Reduction:** ABM helps the Firm to identify opportunities in order to streamline or reduce the costs or eliminate the entire activity, especially NVA activities. It is useful in identifying and quantifying process waste, leading to continuous process improvement through continuous cost reduction.
2. **Activity Based Budgeting:** Activity based budgeting analyses the resource input or cost for each activity. It provides a framework for estimating the amount of resources required in accordance with the budgeted level of activity. Actual results can be compared with budgeted results to highlight (both in financial and non-financial terms) those activities with major discrepancies for potential reduction in supply of resources. It is a planning and control system, which supports continuous improvement.
3. **Business Process Re-Engineering (BPR):** BPR is the analysis and redesign of workflows and processes in a Firm, to achieve dramatic improvement in performance, and operational excellence. A business process consists of linked set of activities, e.g. purchase of materials is a business process consisting of activities like Purchase Requisition, Identifying Suppliers, preparing Purchase Orders, mailing Purchase Orders and follow up. The process can be reengineered by sending the production schedule direct to the suppliers and entering into contractual agreement to deliver materials according to the production schedule.
4. **Benchmarking:** It involves comparing the Firm's products, services or activities with other best performing organizations, either internal or external to the Firm. The objective is to find out how the product, service or activity can be improved and ensure that the improvements are implemented.
5. **Performance measurement:** Activity performance measures consist of measures relating to costs, time quality and innovation. For achieving product quality, some illustrative performance measures are :

Area	Measures
• Quality of purchased component	• Zero defects
• Quality of output	• Percentage yield
• Customer awareness	• No. of orders, no. of complaints

### 3.4.2.7 The Role of the Management Accountant

The Management Accountant plays a central role in creating and maintaining activity-based cost information to support activity-based management. Serving as the financial expert on cross functional work teams, Management Accountants support analysis of current performance, identification of improvement efforts, and prioritization of potential projects. The role of Management Accountants in ABM efforts comprises the following activities:

- Creation of the ABC database;
- Maintenance of the ABM data warehouse;
- Assurance and monitoring of data integrity within the warehouse;
- Analysis of the costs and benefits of improvement projects;
- Ongoing audit and analysis of project performance against goals;
- Creation and support of management reporting structures;
- Provision of cost estimates and reports to meet management's decision-making needs;



- Participation on cross-functional teams at all levels of the organization;
- Education of line managers on the economics of business within process settings;
- Participation in the development of desktop decision support tools for line managers;
- Creation and revision of cost estimates as process changes are made;
- Target and life-cycle cost and profit analysis;
- Strategic and operational budget and planning support; and
- Tracking the results/benefits of the ABC/ABM initiative.

In some organizations, Management Accountants are driving process management efforts, but this can result in ABM being seen as another accounting tool rather than as a management technique to improve profitability and performance against customer expectations. If management accounting does drive the ABM project, it is critical that a strong champion outside the finance group be recruited to support the implementation

### 3.4.2.8 Activity Based Management (ABM) and Enterprise Performance Management (EPM)

The term Enterprise Performance Management (EPM) also termed in different ways, EPM, PM etc. Sometimes it is also used interchangeably with the individual performance and organizational performance. Performance Management is the process of managing the execution of an organization's strategy. It integrates the business improvement methodologies with technology. So it is neither the methodologies only nor the technology in isolation.

Activity Based Management (ABM) is the way to manage business by managing the activities to provide improved value to the customer or organizational performance.

The EPM starts with the definition of the strategy. Let us have a look at the following figure:

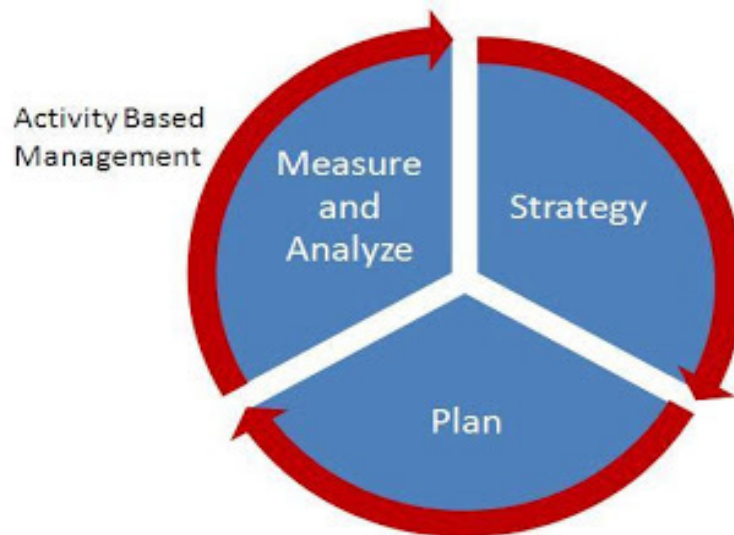

### Enterprise Performance Management

Defining the strategy of an organization, preparing business plan according to the strategy and then measuring the performance and analyzing the variances with reasons to modify the internal processes or strategy is a cyclic process. ABM fits into the 'Measure and Analyze' part of the cycle. Here the ABM model based on the business plan can provide the information on the resource requirement in the future as well measure the actual performance. Once you analyze the actual performance against the planned one, the same can be analyzed using various techniques like root cause analysis,

continuous improvement etc. The analysis will tell whether one has to manage the processes to improve the customer value or organizational performance.

The performance management is also seen as the operational performance management or strategic performance management, as it is mentioned in the earlier part.



Operational performance management is looking at the processes to improve organizational performance and strategic performance management is looking at the processes to improve the value to the customer. The ABM model can be designed to manage the performance at both the levels. It can also be used for some tactical purposes as managing a customer segment or a product group etc.

Looking at all those things the tool vendors have combined their software solutions into one group as Enterprise Performance Management (EPM) suite. This suite generally includes the solutions for Strategy Management, Business Planning and Profitability & Cost Management.

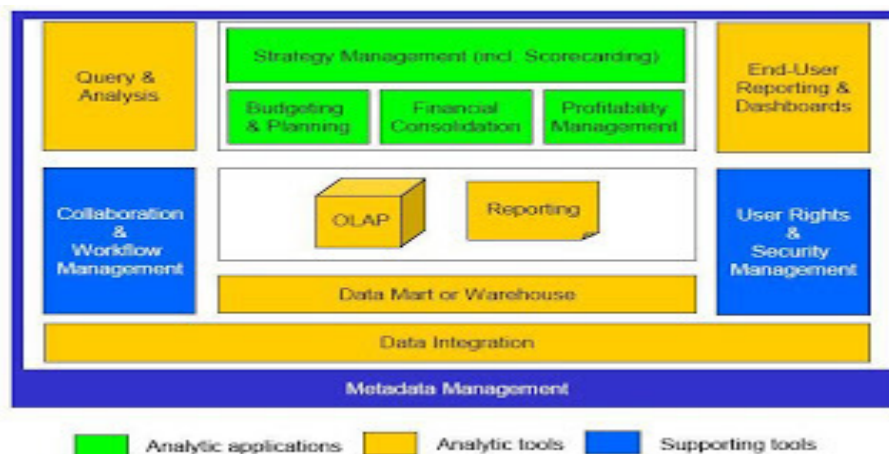

In a very simple way, explained this diagram. It shows three different parts. Analytical tools as in the technological part that helps us to analyze the results. One may argue as to reporting is not exactly same as analytics. The second part is the analytical applications which are actually the software solutions based on the various business improvement methodologies. The third part is supporting tools which help us to integrate the data and perform the administrative part for those solutions. All these solutions work on the same data mart or warehouse so as to provide one view of the data and these solutions use and provide data to the other solutions through this data mart or warehouse.

The Strategy Management methodology creates a strategy map, the Key Performance Indicators (KPIs) and corresponding action plans. Based on the strategic plan the budgeting and planning solution can create the business plan. It can also use the Profitability management solution (ABM) to create a driver based planning. ABM can also provide the actual values for various KPIs defined. The Activity analysis using the cost drivers and performance measures can provide information the performance of the organization vis-à-vis the planned one.

As we saw ABM fits into Enterprise Performance Management (EPM), conceptually as well as technologically and helps the organization to manage the performance at the strategic level as well as operational level (including the tactical one).

### **Case Studies**

#### **Activity-based management in a small company:**

The analysis and cost of activities provide financial and non-financial information which is the basis for Activity-Based Management (ABM). ABM makes this cost and operational information useful by providing a value analysis, cost drivers and performance measures to initiate, drive or support improvement efforts, and hence to improve the decision-making processes. Cost Accounting Management-International (CAM-I) defines ABM as a discipline that focuses on the management of activities as the route to improving the value received by the customer and the profit achieved by providing this value. This discipline includes cost drivers analysis, activity analysis and performance measurements. ABM draws on Activity-Based Costing (ABC) as its major source of information (Berliner and Brimson 1988).

The goals of ABC can be achieved by managing the activities. It is important to realize that managing activities is not a custodial task. Rather, it is a process of relentless and continuous improvement of all aspects of a business. This involves a continual search for opportunities to improve which in turn involves a careful and methodical study of activities (Kaplan 1984).

Here, a real life example of the photo framing industry, G. E. Mustill (GEM), has been considered to explain the application of ABM in a small company. In this project, an ABC system is used to accurately calculate the cost of the company's main product (four-head foiler) and cost of different subassemblies to a make or buy decision. ABC helps to analyze different activities in the company and to differentiate between value-added and non-value-added activities. The aim of ABM is to guide improvement efforts of management in the right direction by providing accurate information about activities.

#### **Activity-Based Management**

Each organization requires information to make decisions, set priorities, allocate resources and monitor the actions taken. ABC performs the arithmetic to provide accurate cost information, and ABM is focused on using this information to manage activities. Improving business based on the information obtained from ABC is called as ABM. ABM is a management analysis that brings the full benefits of ABC to an organization. A conceptual model developed as shown in the following figure is used to describe ABM.

#### **Analysis of activities**

The analyses of activities involve: (i) identification of value-added and non-value-added activities; (ii) analysis of critical activities; and (iii) comparison of the performance of those activities with that of benchmarked.

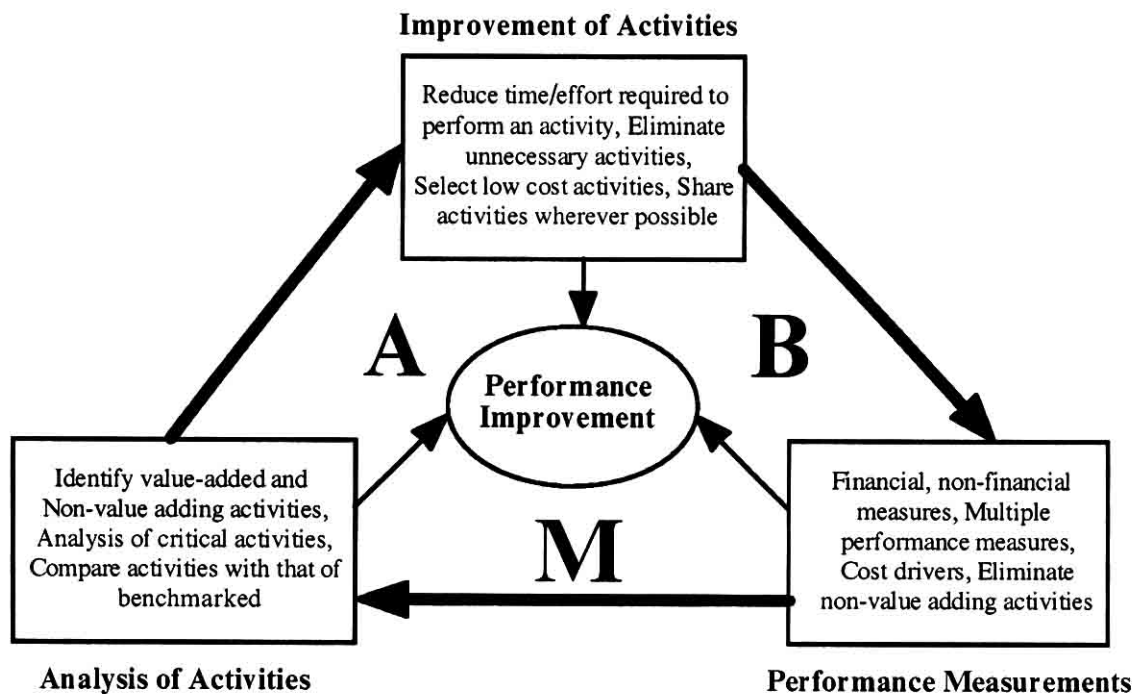

### Identify value-added and non-value-added activities

Once activities are specified and the cost of each activity is calculated, the next step is to identify value-added and non-value-added activities. This judgement should be made within the context of company-wide and well-understood definitions for the terms. A non-value-added activity is often defined as 'an activity that can be eliminated with no deterioration of product attributes (e.g. performance, functionality, quality, perceived value)' (Miller 1992).

Making non-value-added cost visible is one of the major benefits of ABM, but also the most difficult to achieve (David and Robert 1995). Also, defining what value is added versus what non-value is added can be problematic. Definition of a value-added and non-value-added activity is often confused and misunderstood. Some think that non-value-added activity means waste, to others it might mean the cost of quality and to others it might mean everything other than the labour. The reporting of non-value-added activities and costs can quickly become a people's issue because no one wants to be labeled as performing non-value-added activities, e.g. labeling can easily be considered a threat to job security. Therefore, ABM should focus on the activities, not on the people who perform the activities.

Clarity and understanding between value-added and non-value-added activities are achieved when people understand and accept the reasons why an activity is classified as non-value added or value added (Miller 1996). Most people perform their value-added analysis by simply designating an activity value added or non-value added. This level of analysis is insufficient because every value-added activity includes non-value-added steps or tasks. A more thorough analysis should be under-taken to identify the potential for improvement in value-added activities. The following are a few examples of non-value-added activities in an organization.

- Machine setup is a non-value-added activity (as the machine is not producing anything while being setup).
- Logistics in the factory is another non-value-added activity (moving a product does not make it more valuable).
- Inspection is a non-value-added activity.

- Stock holding is a non-value-added activity (inventories do not add value to a product or customers).

Rework is one of the non-value-added activities that can be found in any industry. Nevertheless, this activity is a value-added activity for an operator who performs rework on a job because he/she increases the value of a product by rework. Therefore, all aspects of an organization should be considered while identifying value-added and non-value-added activities.

### **Analysis of critical activities**

In a SME, generally the number of activities in a business may range from 10 to 200. It is not possible to analyze all of them at once due to limited time and resources. The key is then to focus on the most critical activities that will add value to customers or help the effective operation of the business. Moreover, these are the activities that provide the significant opportunities for improvement. The Pareto Analysis can be used to determine the critical activities. This analysis should be carried out separately for both the value-added and non-value-added activities. The activities can be ranked in descending order of cost and the cumulative percentage of the cost of all the activities can be calculated. Then, it can be found that 20% of the activities causes 80% of the total cost, and those activities are worth analyzing.

### **Compare activities with benchmarking**

All activities should be compared with similar activities in another company or within the organization which performs the best in class. Benchmarking should be carried out for both value-added and non-value-added activities. Comparing an activity with a benchmarked of good practice helps to determine the scope for further improvement. The activities should be measured based on factors, e.g. quality, lead-time, flexibility, and cost and customer satisfaction. Then, each activity should be rated against an identified best practice (Coburn *et al.* 1995).

A company with a number of different departments can improve the efficiency and effectiveness of each activity by comparing similar activities of different departments. Obtaining information from other companies is quite difficult. Therefore, benchmarking within the company or with the best practice is mostly used in real-life situations. For example, on-time delivery of customer orders is an essential activity and it can be performed manually. The best practice, however, uses Electronic Data Interchange (EDI) that costs less per transaction, has a lower error rate and provides a faster service. This clearly shows that there is room for improvement over manual order taking (Turney 1992).

Example, the time to set up a machine can be reduced by improved training, eliminating conflicts in employee assignments, placing tools and dies in convenient location, and changes in the product design. For example, a reduction of 90% in setup time is not unusual (Turney 1996). Reduction in time and effort may come not from the activity in question, but may be from the preceding activity. For example, the defect rate of parts received by a machining activity is a cost driver for that activity. Improving quality in the preceding activity reduces the quantity of this cost driver and hence the overall efforts required by the machining process.

### **Eliminate Unnecessary Activities**

Some activities are candidates for elimination because they are not valued by customers or not essential to running the organization. It is possible, e.g. to eliminate material handling activities through changes to the process or products, e.g. reducing the number of components, using GT cells or even by outsourcing (Turney 1996).

There are a number of different options to eliminate any unnecessary activities. In any organization, steps should be taken to ensure that all incoming materials and parts are fit for use. The parts can then be delivered directly to the shop floor as needed. For instance, changes can be requested in the vendors production process to improve quality, flexibility and increase the responsiveness. The parts that cause quality problems can be eliminated by instilling the responsibility of delivering quality products onto suppliers. Once these changes have been made, all the activities of a storeroom can be

eliminated. Activities, e.g. material handling and inspection will be reduced automatically. Eliminating these activities will reduce the overall cost and the cost of products that no longer use these activities.

### **Select Low Cost Activities**

Designers of products and processes often have choices among competing activities. This offers a means for reducing cost by picking the lowest cost activity (Miller 1996). A designer of a product may be able to specify the type of activity required for the assembly of a product. Depending on the design of components, several automatic assembly lines can be used for the assembly of a product instead of manual assembly of a product. Each of these activities has a different set of resources associated with it. Manual assembly is a direct labour activity. An automatic assembly, however, requires equipment, software, skilled workers, and additional process engineering and training. Because these activities have different costs, the selection of an activity has an important impact on the cost.

The process designer faces similar choices. For example, a part designed for machine insertion might also be inserted manually. A process designer may choose to have the part inserted manually because a reduction in the batch size makes it uneconomical to program and setup an insertion machine.

### **Sharing of activities**

If a customer has unique needs, it is necessary to perform activities specific to that customer. However, if customers have common needs, it is wasteful not to serve those needs with the same activities. For example, product designers can use the common parts in new product designs. A common part is one which is used in several products to perform the same function (e.g. a gasket used in several car models). The only parts that need to be unique are those that add product differentiating functions as valued by the customers (Turney 1996).

The activities associated with the common parts, e.g. part number maintenance, scheduling and vendor relations, are shared by all products that use them. This sharing increases the volume of parts produced each time when an activity is carried out, thus reducing the cost per part.

The process designer can also cut costs by grouping of products into work cells. This is possible when products have similar designs (members of a product family) and when the manufacturing process is sufficiently flexible to handle any differences in parts. The cost has decreased because the products in the cell share activities, e.g. supervision, testing, training, scheduling, material handling, storage and documentation.

### **Performance Measurements**

In an ABM system, performance measures include both financial and non-financial measures, and are designed to influence the behaviour of cost management. A fundamental issue is that a single performance measure will not reflect all the aspects of a company. Managers may require multiple performance measures even from individuals (Innes *et al.* 1994). Generally, activities involve groups of employees, and the performance measures therefore usually relate to the group rather than the individual and to the process as well as the output or result.

The ABM system uses cost drivers of a company's activities as a basis for changing the performance measurement system. In particular, some companies are concentrated on non-financial operational performance measures to monitor the improvements in their business processes. It is important to appreciate those performance measures which not only attempt to measure the performance, but also control and evaluate the performance, and motivate the people. The behavioural impact of performance measures is one of the most significant aspects of ABM.

Cost drivers, e.g. the number of purchase orders or the number of engineering changes, are used as a part of the performance measurement system. Some companies use physical measures, but others monitor the unit cost per driver, e.g. the cost of a purchase order. Performance measures should be selected carefully and tailored to the individual processes or organization. Each company must consider the activities which are critical to its business success. Greene and Flentov (1991) suggest certain general guidelines for selecting performance measures.

- The performance measures chosen should assist in monitoring the progress of controlling activity costs. These include throughput time, and the number of engineering changes and production schedule changes.
- The performance measures selected should be reviewed periodically. As the business and the internal and external environments of a business change, performance measures may have to also change accordingly.
- Everyone should be able to understand the performance measures. These not only must be clearly defined, but also the relationship to the company's strategic objectives must be explained.
- The performance indicators relevant for one individual or group should not be too many.
- Daily operations should be managed on the basis of these key measures.
- The evaluation of employees should be linked to the performance indicators selected.
- The selection of these performance indicators is a critical process and the success of this process depends upon a sound analysis of the critical activities for that particular business.
- Whilst activities-based approaches are not a panacea nor even an end in themselves, they do at least recognize the need to effectively manage the activities of a business. This should be rectified in the way the costs are reported and performance measures are employed (Marrow 1992). The analysis of activities as value added and non-value added is the basis of ABM.

### **Activity-based management at G. E. Mustill- a case study**

G. E. Mustill (GEM) is a small company with £0.5 million annual turnover. It employs about 20 people and is located in Essex, England. The main products of GEM are four types of machines (viz. sander, splitter, shaper and foiler) for the picture framing industry. The foiler and sander machines are produced in different numbers of heads varying from 1 to 6. They produce machines in standard specifications and according to customers' requirements. The company manufactures only 22% of parts of the machine in-house and purchases 78% of parts from subcontractors and suppliers. The assembly of all these parts is the main activity of the company. The company works in a traditional way and all activities are performed manually.

Information provided by an ABC system is used to find the opportunities of improvement in organization at the activity level. The analysis of activities involves classification of activities into value added and non-value added, and then compares these with that of the world class company or the best practices. Benchmarking with the best practice offers avenues for improvement in value-added activities. This also explains how management can use the cost drivers as the performance measures and control the volume of cost drivers. The ideal cost object is 'products' that are sold to customers. The cost of all activities is calculated in a similar way to that of parts. The total cost of a four-head foiler is shown in table 1.

- Marketing. The annual cost of marketing is £23,330 which is divided equally between four types of machines. Then, this amount is divided by eight because the annual sale of a four-head foiler is eight machines. Therefore, the marketing cost for this product is £ 729.06.
- Inventory carrying cost. The cost driver for inventory carrying is the stock value. The total stock value in GEM is £20,000. For a four-head foiler, the stock value is £ 1600. Hence, the inventory carrying cost for this machine is £491.20.
- Engineering support. The cost driver for this activity is the time spent by the engineering support staff for a particular product. For this machine, a total of 80 h is spent by the engineering staff and hence the cost of engineering support activity is £ 1480.
- Assembly. The assembly of the machine is performed manually. The cost driver for assembly activity is the labour hours and the volume of the cost driver is 82 h. This leads to the total assembly cost as £ 886.42.

**Table 1. Cost of a four-head foiler.**

Activity	Cost driver	Cost driver rate £	Cost driver volume	Cost £
Assembly	labour hours	10.81	82 h	886.42
Material handling	no. of movements	0.2	1020 movements	204.00
Inspection	no. of inspection	0.41	450 inspection	184.50
Purchasing	no. of orders	20.65	16 orders	330.40
Marketing	no. of product	729.06	1	729.06
Inventory	stock value	0.307	£ 1600	491.20
Engineering support	staff hours	18.5	80 h	1480.00
Personnel	labour hours	0.64	470 h	300.80
Misc. overhead	labour hours	1.6	520 h	832.00
Manufactured parts				1306.88
Direct material				9773.0
<b>Total cost</b>				<b>16,518.3</b>

### Analysis of Activities

ABC provides detailed information about the company and its activities. This detailed information can be used by the management to initiate improvements and decision-making. The percentage cost of all activities is shown in figure below. This shows that engineering support activities carry 22.21% of the total cost of all activities. In the traditional costing system, there is no such information available on this.

Once the cost of each activity is calculated, the next step is to identify the value-added and non-value-added activities. According to the definition of a non-value added activity (an activity that can be eliminated with no deterioration of product attributes), all activities are non-value added except activities, e.g. assembly, machining and engineering support. Activities, e.g. marketing, personnel and purchasing do not add value to the product, but these are necessary and cannot be eliminated. Therefore, there are three non-value-added activities, viz. inspection, material handling and inventory. Figure below shows the percentage of value-added and non-value-added activities. It indicates that non-value-added activities are 16.18% of the total cost of activities. These activities can be eliminated without deterioration of product attributes, e.g. quality, performance and function. By using different quality assurance methods, e.g. TQM, ISO9000 and dynamic process control, quality can be maintained during production and hence there is no need for an inspection. Similarly, material handling and inventory-related activities can be eliminated using different methodologies and techniques, e.g. JIT, EDI, CIM and BPR.



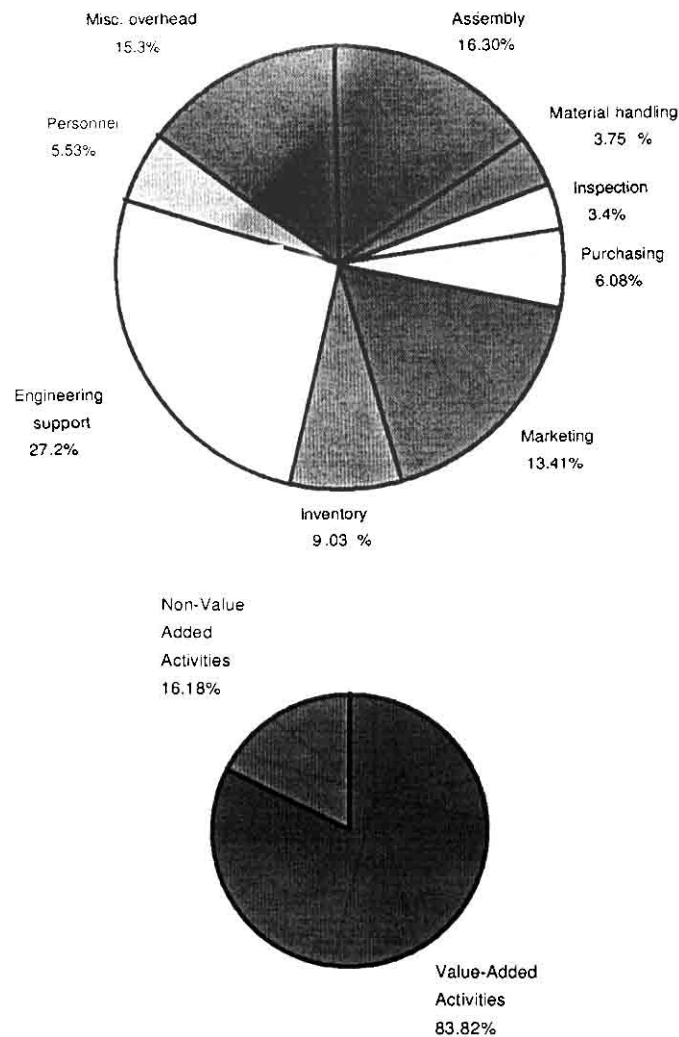

It may not be possible to eliminate or reduce all no value-adding activities at the same time. The key is then to focus on the critical activities which form a major portion of the total cost. Below shows that the inventory carrying cost is 55.81% of the total cost of non-value-added activities. Therefore, activities related to carrying inventory should be eliminated first.

The cost driver for inventory carrying activity is the value of stock. The company should not maintain any stock in order to eliminate related activities. This could be possible by the introduction of just-in-time purchasing. At the same time, the cost of purchasing should be closely monitored. The purchasing department will place more purchasing orders to maintain the minimum stock level. If the company eliminates inventory-related activities and increases the cost of purchasing activity, then there are no benefits in eliminating non-value-added activities.

Similarly, the cost of maintaining quality in processes should be considered in eliminating the inspection activity. Material handling activities cannot be eliminated at the cost that is difficult to justify. Sometime, non-value added activities can be clearly identified, but difficult to eliminate completely. However, it is always possible to reduce the cost of these activities.

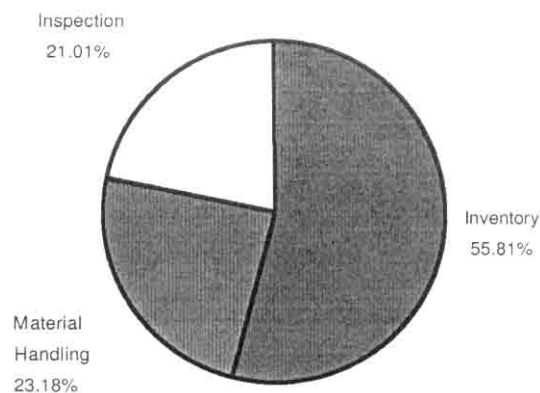

### Compare activities with Benchmarking

All activities related to the manufacturing of a four-head foiler should be compared to similar activities in other companies or within the organization. Benchmarking should be carried out for both value-added and non-value-added activities because value added activities include non-value-added tasks. The comparison of some of the activities of the company with the best in class company's activities is presented below.

- **Purchasing.** World-class companies have a direct link with suppliers and subcontractors by the electronic data exchange (EDI) system, and it places orders automatically whenever materials are required. This leads to a reduction in ordering cost, lead time and overall purchasing cost as compared with that of manual order processing. Hence, there is room for improvement in the purchasing activity of GEM.
- **Assembly.** The assembly activity is performed manually in GEM. Compared to an automatic assembly activity, there are many chances of improvements. The cost of automation should be justified based on the labour cost and response time including tangible and intangible costs and benefits.
- **Material handling.** There are a number of machining stations in GEM, e.g. drilling, milling and turning. The movement of materials between these stations is the cost driver. It is possible to reduce this movement by using multipurpose machines (AS/RS, robots, AGVs) to perform various operations. The movement of materials can also be reduced by changing the layout of machines.
- **Machining operations (drilling, milling, turning, etc.).** GEM uses very old machines to perform these activities and these are labour intensive. Therefore, these machining operations can be compared with that of the CNC machine tools. Similarly, all the activities can be compared with the best practices. Benchmarking at each activity level helps to determine the scope of improvements.

### Performance measurements

In ABM, performance of GEM should be measured at an activity level, and performance measures include both financial and non-financial measures. The volume of the cost driver indicates the performance level of each activity.

For example, the cost driver for an assembly activity is labour hours. If labour hours required performing the assembly activity increases, then this indicates that the performance of the assembly activity is poor. If labour hours decrease, then the performance of the assembly activity improves which in turn leads to a reduction in the cost of the product and hence an increase in the profit level. Similarly, appropriate cost drivers are performance measures for all identified activities in the company.

From the analysis of activities, the value-added and non-value-added activities are clearly identified. In GEM, the inventory carrying activity is the major non-value-added activity which should be eliminated.

However, it is difficult because the purchasing cost of the present system will increase as the company places more purchased orders with the objective to reduce inventories. Therefore, it indicates that the purchasing activity should also improve. The comparison of this purchasing activity with the best practice (purchasing using EDI) indicates the scope for improvements. ABM uses ABC information to motivate the people in improving and monitoring the performance of their activities.

Management practices and methods have been changed over the last decade, and organizations are moving from managing vertically to manage horizontally. Activity-Based Costing and Activity-Based Management provide cost and operating information that mirror the horizontal view. ABC provides accurate cost information and ABM uses this information to initiate improvements. ABC systems produce a large amount of information that is used by the ABM. The costing at part level or sub-assembly level helps the management in a make or buy decision. The analysis of activities to identify value-added and non-value-added activities and benchmarking at the activity level direct improvement efforts in the right direction.

The benefits of ABC and ABM can only be achieved if it is applied for the whole organization. Therefore, GEM should use activity-based analysis to identify non-value-added activities (e.g. inventory carrying, material handling and inspection), and then try to eliminate these activities by using the number of available management methods and techniques. Also, there are possibilities to improve value-added activities. The cost driver of activities should be used to measure the performance of activities.

### 3.4.3 Life Cycle Costing

Many products generally have characteristic of perishable distinctiveness. The distinctiveness of a product degenerates over a period into a common commodity. This process by which the distinctiveness gradually disappears as the product merges with other competitive products has been rightly termed by Joel Dean as 'the cycle of competitive degeneration'. The cycle begins with the identification of new consumer need and the invention of a new product and is often followed by patent protection and further development to make it saleable. This is usually followed by a rapid expansion in its sales as the product gains market acceptance. Then competitors enter the field with imitation and rival products and the distinctiveness of the new product starts diminishing. The speed of degeneration differs from product to product. The innovation of a new product and its degeneration into a common product is termed as the life cycle of a product.

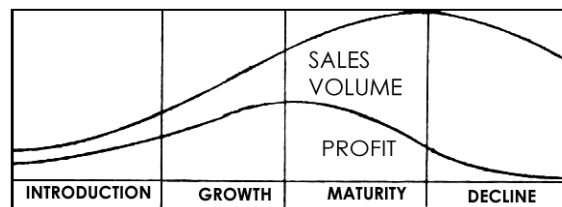

- (i) **Introduction Phase** - Research and engineering skill leads to product development. The product is put on the market and its awareness and acceptance are minimal. Promotional costs will be high, sales revenue low and profits probably negative. The skill that is exhibited in testing and launching the product will rank high in this phase as critical factor in securing success and initial market acceptance. Sales of new products usually rise slowly at first.
- (ii) **Growth Phase** - In the growth phase product penetration into the market and sales will increase because of the cumulative effects of introductory promotion, distribution. Since costs will be lower than in the earlier phase, the product will start to make a profit contribution. Following the consumer acceptance in the launch phase it now becomes vital or secure wholesaler/retailer support. But to sustain growth, consumer satisfaction must be ensured at this stage. If the product is successful, growth usually accelerates at some point, often catching the innovator by surprise.
- (iii) **Maturity phase** - This stage begins after sales cease to rise exponentially. The causes of the declining percentage growth rate is the market saturation – eventually most potential customers have tried

the product and sales settle at a rate govern by population growth and the replacement rate of satisfied buyers. In addition there were no new distribution channels to fill. This is usually the longest stage in the cycle, and most existing products are in this stage. The period over which sales are maintained depends upon the firm's ability to stretch the cycle by means of market segmentation and finding new uses for it.

**(iv) Decline phase** - Eventually most products and brands enter a period of declining sales. This may be caused by the following factors:

- Technical advances leading to product substitution.
- Fashion and changing tastes.
- Exogenous cost factors will reduce profitability until it reaches zero at which point the product's life is commercially complete.

It can be described by the following table:

The 4 identifiable phases in the Product Life Cycle are - (a) Introduction (b) Growth (c) Maturity and (d) Decline.

A comparative analysis of these phases is given below

Particulars	Introduction	Growth	Maturity	Decline
Phases	I	II	III	IV
<b>Sales Volumes</b>	Initial stages, hence low	Rise in sales levels at increasing rates.	Rise in sales levels at decreasing rates.	Sales level off and then start decreasing
<b>Prices of products</b>	High levels to cover initial costs and promotional expenses.	Retention of high level prices except in certain cases	Prices fall closer to cost, due to effect of competition	Gap between price and cost is further reduced.
<b>Ratio of promotion expenses to sales</b>	Highest, due to effort needed to inform potential customers, launch products, distribute to customers etc.	Total expenses remain the same, while ratio of S&D OH to sales is reduced due to increase in sales	Ratio reaches a normal % of sales. Such normal % becomes the Industry standard.	Reduced sales Promotional efforts as the product are no longer in demand.
<b>Competition</b>	Negligible and Insignificant.	Entry of a large number of competitors.	Fierce Competition.	Starts disappearing due to withdrawal of products.
<b>Profits</b>	Nil, due to heavy initial costs	Increase at a rapid pace.	Normal rate of profits since costs and prices are normalized.	Declining profits due to price competition, new products etc.

### 3.4.3.1 Characteristics of product life-cycle

The major characteristics of product life-cycle concept are as follows:

- The products have **finite lives** and pass through the cycle of development, introduction, growth, maturity, decline and deletion at **varying speeds**.
- Product cost, revenue and profit patterns tend to **follow predictable courses** through the product life-cycle. Profits first appear during the growth phase and after stabilizing during the maturity phase, decline thereafter to the point of deletion.
- **Profit per unit** varies as products move through their life-cycles.

- Each phase of the product life-cycle poses **different threats and opportunities** that give rise to different strategic actions.
- Products require **different functional emphasis** in each phase-such as an R &D emphasis in the development phase and a cost control emphasis in the decline.

### 3.4.3.2 Importance

Product Life Cycle Costing is considered important due to the following reasons-

1. **Time based analysis:** Life cycle costing involves tracing of costs and revenues of each product over several calendar periods throughout their life cycle. Costs and revenues can be analyzed by time periods. The total magnitude of costs for each individual product can be reported and compared with product revenues generated in various time periods.
2. **Overall Cost Analysis:** Production Costs are accounted and recognized by the routine accounting system. However non-production costs like R&D, design, marketing, distribution, customer service etc. are less visible on a product-by-product basis. Product Life Cycle Costing focuses on recognizing both production and non-production costs.
3. **Effective Pricing Decisions:** Pricing Decisions, in order to be effective, should include market considerations on the one hand and cost considerations on the other. Product Life Cycle Costing and Target Costing help analyze both these considerations and arrive at optimal price decisions.
4. **Better Decision Making:** Based on a more accurate and realistic assessment of revenues and costs, at least within a particular life cycle stage, better decisions can be taken.
5. **Long Run Holistic view:** Product life cycle thinking can promote long-term rewarding in contrast to short-term profitability rewarding. It provides an overall framework for considering total incremental costs over the entire life span of a product, which in turn facilitates analysis of parts of the whole where cost effectiveness might be improved.
6. **Life Cycle Budgeting:** Life Cycle Budgeting, i.e. Life Cycle Costing with Target Costing principles, facilitates scope for cost reduction at the design stage itself. Since costs are avoided before they are committed or locked in the Company is benefited.
7. **Review:** Life Cycle Costing provides scope for analysis of long term picture of product line profitability, feedback on the effectiveness of life cycle planning and cost data to clarify the economic impact of alternatives chosen in the design, engineering phase etc.

### 3.4.3.3 Experience curve in product life-cycle costing

The essence of experience curve theory is that the real cost of generating products and service decline by between 20 and 30 percent whenever cumulative experience doubles. An important distinction needs to be drawn between the experience curve and the learning curve. The latter relates to labour hours and hence labour cost. As a consequence, the reduction in costs due to the learning curve is much lower than that due to the broader based experience curve. All costs and cost effects are reflected by the experience curve. Several causes of cost reduction act together within the experience curve, such as the learning experience, the effect of labour specialization and scale effects due to increased volume.

The experience curve is not derived from accounting costs but by dividing the cumulative cash inputs by the cumulative output of end products and the cost decline is shown by the rate of change in this ratio over a period of time. From this rate of change managers can see how and why their competitive costs are shifting. If estimates can be made of competitors' experience curve effects, this should reveal which are the low-cost competitors and which are not, and hence which are at risk and from whom.

The main strategic message from the experience curve is that if costs per unit in real terms decrease predictably with cumulative output, then the market leader has the potential to achieve the lowest costs and the highest profits.

It is relatively easy for management to recognize the profit implications of design changes, product obsolescence, price variations and so on in isolation for a particular product. Yet insufficient acceptance of the concept of the product life cycle as a basis for planning the overall strategy of a product seems to exist. A product life-cycle is a way of portraying the cash flow, profitability and sales level of a product. Product life cycle is represented in terms of funds flow. Prior to its launch all funds flows are negative due to R&D and related activities. Even after launch it takes some time for positive funds flows to counteract the heavy initial promotional and other launch outlays. When the product is deleted, funds cease flowing altogether.

#### **3.4.3.4 Project life – cycle costing**

Project life-cycle costing is a technique which takes account of the total cost of owning a physical asset, or making a product, during its economic life. In many instances, the purchase of equipment is decided solely on the criteria of initial acquisition costs. Operating plans do not usually spell out the implications for the cost of operating physical assets during the current or future financial periods. Maintenance policies may be only infrequently reviewed.

The term 'project life-cycle cost' has been defined as follows: ' it includes the costs associated with acquiring, using, caring for and disposing of physical assets, including the feasibility studies, research, design, development, production, maintenance, replacement and disposal, as well as support, training and operating costs generated by the acquisition, use, maintenance and replacement of permanent physical assets.'

#### **Project life-cycle costs**

Product life-cycle costs are incurred for products and services from their design stage through development to market launch, production and sales, and their eventual withdrawal from the market. In contrast project life-cycle costs are fixed assets, i.e., for capital equipment and so on.

The component elements of a project's cost over its life-cycle could include the following:

- (a) Acquisition cost, i.e., costs of research, design, testing, production, construction, or purchase of capital equipment.
- (b) Transportation and handling costs of capital equipment.
- (c) Maintenance costs of capital equipment.
- (d) Operations costs, i.e., the costs incurred in operations, such as energy costs, and various facility and other utility costs.
- (e) Training costs i.e., operator and maintenance training.
- (f) Inventory costs i.e., cost of holding spare parts, warehousing etc.
- (g) Technical data costs i.e., cost of purchasing any technical data.
- (h) Retirement and disposal costs at the end of life or the capital equipment life.

The costs in (c ) to (h) are, incurred over the project's life or the equipment life, and some of the costs will increase as the product or equipment gets older (for example maintenance costs). However, crucial decisions which will affect the level of these costs are taken at an early stage.

#### **3.4.3.5 Distribution of Costs over the Asset Life Cycle**

Life Cycle Costing can be carried out during any or all phases of an asset's life cycle. It can be used to provide input to decisions regarding asset design, manufacture, installation, operation, support and disposal.

By the end of the concept and definition phases of acquisition, more than half of the asset's life costs may be committed by decisions made with respect to asset features, performance, and reliability, technology, and support resources. By the end of design and development phases, even more of the

asset's life costs may be fixed. The interaction between potential savings and asset costs is shown in Figure below - Potential Savings and Cost Relationship.

Early identification of acquisition and ownership costs enables the decision-maker to balance performance, reliability, maintainability, maintenance support and other goals against life cycle costs. Decisions made early in a asset's life cycle have a much greater influence on Life Cycle Costing than those made late in a asset's life cycle, leading to the development of the concept of discounted costs.

**Figure: Potential Savings and Cost Relationship**

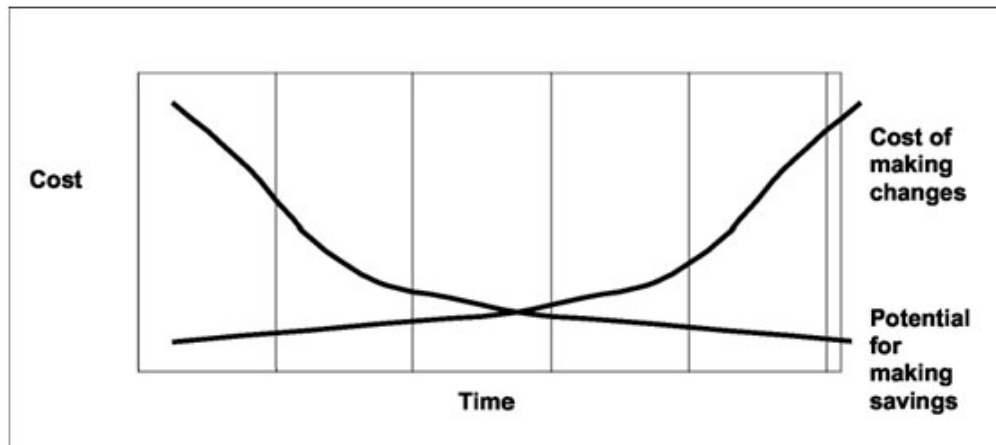

### 3.4.3.6 Linkages with Total Asset Management (TAM)

TAM reflects priorities for whole-of-life asset management, extended planning requirements for new works, and new relationships between services planning and asset procurement activities.

Costs may change and accumulate as a program or project progresses. Initial provisions made to manage whole-of-life costs should be evaluated and updated before committing to one alternative. A LCC model provides a mechanism to compare these costs.

### 3.4.3.7 Modeling life cycle costs

#### Life Cycle costing models

LCC model is an accounting structure containing terms and factors which enable estimation of an asset's component costs.

A number of commercially available models can be used for LCC analysis. However, in some cases it may be appropriate to develop a model for a specific application. In either case, the LCC model should:

- represent the characteristics of the asset being analyzed including its intended use environment, maintenance concept, operating and maintenance support scenarios and any constraints or limitations
- be comprehensive enough to include and highlight the factors relevant to the asset LCC
- be easily understood to allow timely decision- making, future updates and modification
- Provide for the evaluation of specific LCC elements independently of other elements.

Before selecting a model, the purpose of the analysis and the information it requires should be identified. The model should also be reviewed with respect to the applicability of all cost factors, empirical relationships, constants, elements and variables.

### 3.4.3.8 LCC breakdown into asset cost elements

Estimating the total LCC requires breakdown of the asset into its constituent cost elements over time. The level to which it is broken down will depend on the purpose and scope of the LCC study and requires identification of:

- significant cost generating activity components
- the time in the life cycle when the work/activity is to be performed
- Relevant resource cost categories such as labour, materials, fuel/energy, overhead, transportation/travel and the like.

Costs associated with LCC elements may be further allocated between recurring and non-recurring costs. LCC elements may also be estimated in terms of fixed and variable costs.

To facilitate control and decision-making and to support the Life Cycle Costing process, the cost information should be collected and reported in a manner consistent with the defined LCC breakdown structure.

#### Estimating asset cost elements

The method used to estimate asset cost elements in LCC calculations will depend on the amount of information needed to:

- establish asset use patterns and operational characteristics and hence expected asset life
- Understand the technology employed in the asset.

#### Sources of cost data

By definition, detailed cost data will be limited in the early stages of the asset life, particularly during the design/acquisition phase. Cost data during these early stages will need to be based on the cost performance of similar asset components currently in operation.

Where new technology is being employed, data can only be based on estimated unit cost parameters such as ₹/construction unit, construction unit/labour hours, specified or suggested by the technology.

More information on asset component costs will become available during use of the asset, enabling more complete and descriptive costs to be defined.

### 3.4.3.9 Methods of analyses

One or more of the following methods for analyzing cost data should be used.

#### I. Engineering cost method

The Engineering Cost Method is used where there is detailed and accurate capital and operational cost data for the asset under study. It involves the direct estimation of a particular cost element by examining the asset component-by-component.

It uses standard established cost factors (eg. firm engineering and/or manufacturing estimates) to develop the cost of each element and its relationship to other elements (known as Cost Element Relationships - CER).

#### II Analogous cost method

This method provides the same level of detail as the Engineering Cost Method but draws on historical data from components of other assets having analogous size, technology, use patterns and operational characteristics.

#### III Parametric cost method

The Parametric Cost Method is employed where actual or historical detailed asset component data is limited to known parameters.



This available data from existing cost analyses is used to develop a mathematical regression or progression formula that can be solved for the cost estimate required.

### 3.4.3.9 The Life Cycle costing process

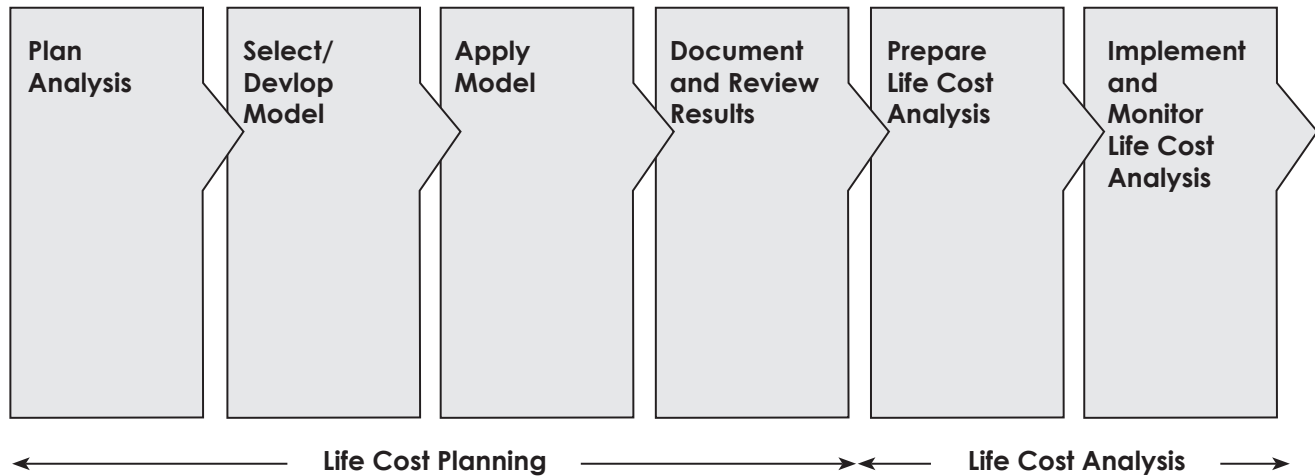

#### Overview

As shown in the above diagram, Life Cycle Costing is a six-staged process. The first four stages comprise the Life Cost Planning phase with the last two stages incorporating the Life Cost Analysis phase. The six stages are:

<b>Stage 1</b>	Plan LCC Analysis
<b>Stage 2</b>	Select/Develop LCC Model
<b>Stage 3</b>	Apply LCC Model
<b>Stage 4</b>	Document and Review LCC
<b>Stage 5</b>	Results/Prepare Life Cost Analysis
<b>Stage 6</b>	Implement and Monitor Life Cost Analysis

All stages may be performed iteratively as needed. Assumptions made at each stage should be rigorously documented to facilitate such iterations and to aid in interpretation of the results of the analysis.

LCC analysis is a multi-disciplinary activity. An analyst should be familiar with the philosophy, which underlies Life Cycle Costing (including typical cost elements, sources of cost data and financial principles), and should have a clear understanding of the methods of assessing the uncertainties associated with cost estimation.

Depending upon the scope of the analysis, it will be important to obtain cost inputs from individuals who are familiar with each of the phases of the asset life cycle. This may include representatives of both the supplier(s) and the user(s).

## Stage 1: Plan LCC Analysis

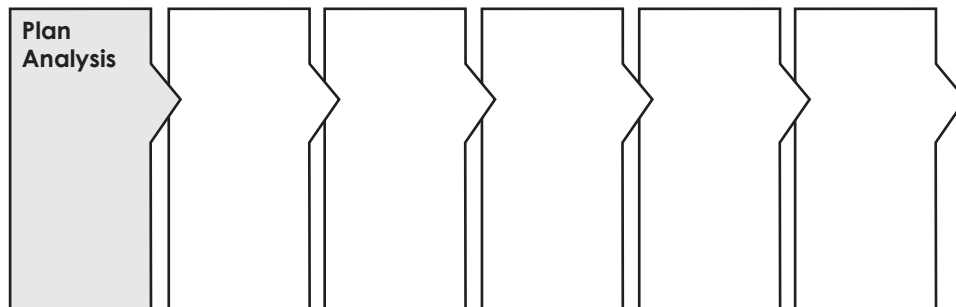

The Life Cycle Costing process begins with development of a plan, which addresses the purpose, and scope of the analysis. The plan should:

- define the analysis objectives in terms of outputs required to assist management decisions. Typical objectives are:
  - Determination of the LCC for an asset in order to assist planning, contracting, budgeting or similar needs
  - Evaluation of the impact of alternative courses of action on the LCC of an asset (such as Design approaches, asset acquisition, support policies or alternative technologies)
  - Identification of cost elements which act as cost drivers for the LCC of an asset in order to focus design, development, acquisition or asset support efforts.
- delineate the scope of the analysis in terms of the asset(s) under study, the time period (life cycle phases) to be considered, the use environment and the operating and maintenance support scenario to be employed.
- Identify any underlying conditions, assumptions, limitations and constraints (such as minimum asset performance, availability requirements or maximum capital cost limitations) that might restrict the range of acceptable options to be evaluated.
- Identify alternative courses of action to be evaluated. The list of proposed alternatives may be refined as new options are identified or as existing options are found to violate the problem constraints.
- Provide an estimate of resources required and a reporting schedule for the analysis to ensure that the LCC results will be available to support the decision-making processes for which they are required.

The plan should be documented at the beginning of the Life Cycle Costing process to provide a focus for the rest of the work. Intended users of the analysis results should review the plan to ensure their needs have been correctly interpreted and clearly addressed.

**Stage 2: Select/develop LCC model**

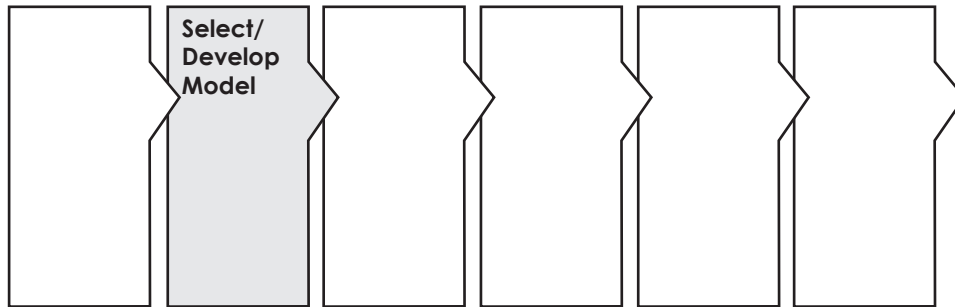

Stage 2 is the selection or development of an LCC model that will satisfy the objectives of the analysis.

**The model should:**

- Create or adopt a cost breakdown structure (CBS) that identifies all relevant cost categories in all appropriate life cycle phases. Cost categories should continue to be broken down until a cost can be readily estimated for each individual cost element. Where available, an existing cost breakdown structure may provide a useful starting point for development of the LCC breakdown structure.
- Identify those cost elements that will not have a significant impact on the overall LCC of the asset(s) under consideration or those that will not vary between alternatives. These elements may be eliminated from further consideration.
- Select a method (or methods) for estimating the cost associated with each cost element to be included in the model.
- Determine the data required to develop these estimates, and identify sources for the data.
- Identify any uncertainties that are likely to be associated with the estimation of each cost element.
- Integrate the individual cost elements into a unified LCC model, which will provide the LCC outputs required to meet the analysis objectives.
- Review the LCC model to ensure that it is adequate to address the objectives of the analysis.
- The LCC model including all assumptions should be documented to guide and support the subsequent phases of the analysis process.

**Stage 3: Apply LCC model**

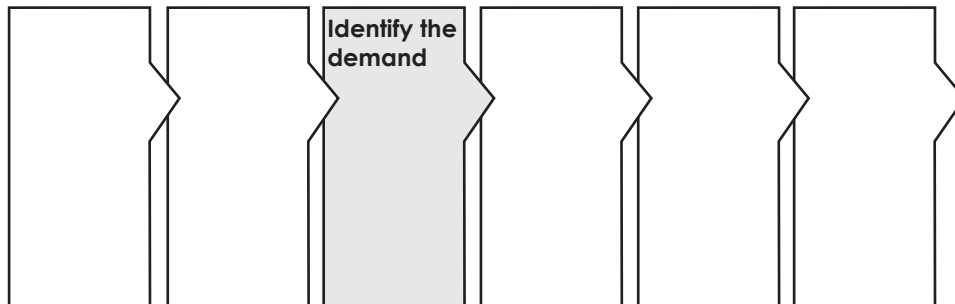

**Application of the LCC Model involves the following steps:**

- Obtain data and develop cost estimates and their timing for all the basic cost elements in the LCC model.
- Validate the LCC model with available historical data if possible.

- Obtain the LCC model results from each relevant combination of operating and support scenarios defined in the analysis plan.
- Identify cost drivers by examining LCC model inputs and outputs to determine the cost elements that have the most significant impact on the LCC of the asset(s).
- Quantify any differences (in performance, availability or other relevant constraints) among alternatives being studied, unless these differences are directly reflected in the LCC model outputs.
- Categorize and Summarize LCC model outputs according to any logical groupings, which may be relevant to users of the analysis results (eg. fixed or variable costs, recurring or non-recurring costs, acquisition or ownership costs, direct or indirect costs).
- Conduct sensitivity analyses to examine the impact of variations to assumptions and cost element uncertainties on LCC model results. Particular attention should be focused on cost drivers, assumptions related to asset usage and different discount rates.
- Review LCC outputs against the objectives defined in the analysis plan to ensure that all goals have been fulfilled and that sufficient information has been provided to support the required decision. If the objectives are not met, additional evaluations and modifications to the LCC model may be required.
- The LCC analysis (including all assumptions) should be documented to ensure that the results can be verified and readily replicated by another analyst if necessary.

#### Stage 4: Document and review LCC Results

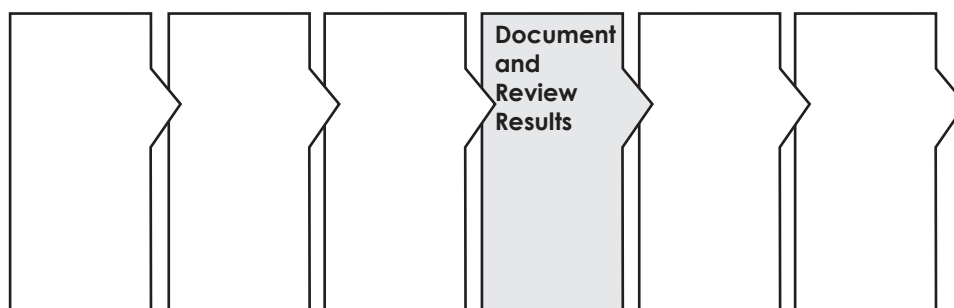

The results of the LCC analysis should be documented to allow users to clearly understand both the outcomes and the implications of the analysis along with the limitations and uncertainties associated with the results. The report should contain the following.

**Executive Summary:** a brief synopsis of the objectives, results, conclusions and recommendations of the analysis.

**Purpose and Scope:** a statement of the analysis objective, asset description including a definition of intended asset use environment, operating and support scenarios, assumptions, constraints and alternative courses of action considered.

**LCC Model Description:** a summary of the LCC model, including relevant assumptions, the LCC breakdown structure and cost elements along with the methods of estimation and integration.

**LCC Model Application:** a presentation of the LCC model results including the identification of cost drivers, the results of sensitivity analyses and the output from any other related analyses.

**Discussion:** discussion and interpretation of the results including identification of uncertainties or other issues which will guide decision makers and users in understanding and using the results.

**Conclusions and Recommendations:** a presentation of conclusions related to the objectives of the analysis and a list of recommendations along with identification of any need for further work or revision of the analysis.

A formal review of the analysis process may be required to confirm the correctness and integrity of the results, conclusions and recommendations presented in the report. If such a requirement exists someone other than the original analysts should conduct the review (to ensure objectivity). The following elements should be addressed in the review:

- the objectives and scope of the analysis to ensure that they have been appropriately stated and interpreted
- the model (including cost element definitions and assumptions) to ensure that it is adequate for the purpose of the analysis
- the model evaluation to ensure that the inputs have been accurately established, the model has been used correctly, the results (including those of sensitivity analysis) have been adequately evaluated and discussed and that the objectives of the analysis have been achieved
- all assumptions made during the analysis process to ensure that they are reasonable and that they have been adequately documented.

**Stage 5: Prepare life cost analysis**

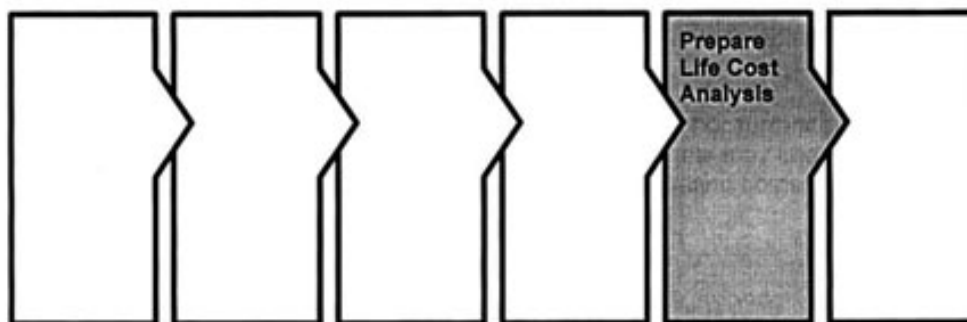

The Life Cost Analysis is essentially a tool, which can be used to control and manage the ongoing costs of an asset or part thereof. It is based on the LCC Model developed and applied during the Life Cost Planning phase with one important difference: it uses data on nominal costs.

The preparation of the Life Cost Analysis involves review and development of the LCC Model as a “real-time” cost control mechanism. This will require changing the costing basis from discounted to nominal costs. Estimates of capital costs will be replaced by the actual prices paid. Changes may also be required to the cost breakdown structure and cost elements to reflect the asset components to be monitored and the level of detail required.

Targets are set for the operating costs and their frequency of occurrence based initially on the estimates used in the Life Cost Planning phase. These targets may change with time as more accurate data is obtained, either from the actual asset operating costs or from benchmarking with other similar assets.

**Stage 6: Implement and monitor life cost analysis**

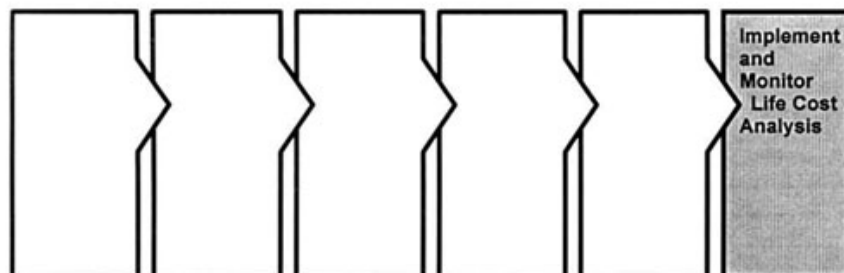

Implementation of the Life Cost Analysis involves the continuous monitoring of the actual performance of an asset during its operation and maintenance to identify areas in which cost savings may be made and to provide feedback for future life cost planning activities.

For example, it may be better to replace an expensive building component with a more efficient solution prior to the end of its useful life than to continue with a poor initial decision.

## **A Case Study of Life Cycle Cost based on a Real FRP Bridge**

### **1. INTRODUCTION**

FRP has some excellent properties as a structural material. Its application to bridges offers a possibility to solve problems that bridges made of conventional materials are facing today such as corrosion and damages incurred early in the life-cycle of a structure. Presently, FRP's unit price is usually rather more expensive than that of other conventional materials. This may increase the initial cost of the FRP superstructure and is one of the obstacles deterring widespread use of the material in FRP bridges.

In order to evaluate the benefit of using FRP in bridges, it is important to consider FRP's life cycle cost (LCC) including the cost for maintenance. There has been some research on the cost benefit of FRP structures; however, because some of those studies begin with the design of the structures and include many suppositions, the LCC estimates of FRP structures are not so reliable.

With this in mind, the authors tried to evaluate the LCC of an actual FRP footbridge, remaining as faithful to actual conditions as possible. The case study is based on an FRP footbridge constructed in Okinawa, Japan, in 2000. It is called "Okinawa Road Park Bridge".



**Figure: View of the Okinawa Road Park Bridge**

### **2. THE STRUCTURES FOR THE CASE STUDY**

A FRP footbridge and PC footbridge crossing a 4-lane road were considered as the case models. The bridges are located close to the seashore and severely affected by sea salt. The main girders of the FRP footbridge are made of hand lay-up FRP; pultruded FRP is used for the stiffeners, decks, and floor systems. Both types of FRP were made of glass fiber and vinylester resin. Parts of the FRP footbridge were made in several factories within the Tokyo area, assembled in a factory in Tokyo Bay, and then shipped to Okinawa. Wall type piers and steel pipe pile foundations were used in the substructure for both bridges.

Table : Model cases of FRP and PC bridges

	FRP bridges	PC bridges
<b>Concept</b>	Two span girder bridge with GFRP C-girders	Single span deck girder bridge with hollow post-tension concrete beams
<b>Length</b>	37.8m	36.0m
<b>Span</b>	19.7m+17.2m	35.0m
<b>Width</b>	4.3m	4.3m
<b>Live load</b>	350kgf/m <sup>2</sup> for main girders	
	500kgf/m <sup>2</sup> for decks	

### 3. Calculation Method of LCC

Direct construction costs of the initial cost and the maintenance cost for both FRP and PC bridges were calculated based on the design reports for both bridges. LCC was obtained by the equations

$$L_{FRP\ bri} = I_{FRP\ bri} + M_{FRP\ bri}$$

$$L_{PC\ bri} = I_{PC\ bri} + M_{PC\ bri}$$

Where,

**L: Life Cycle Costing**

**I: Initial cost**

**M: Maintenance cost**

We did not calculate the cost for disuse neither did we consider the discount rate to discount future costs to the base year. Initial costs were calculated for both the superstructure and substructure. Maintenance costs were calculated only for the superstructure.

### RESULTS

Initial costs

PC footbridges

Five types of superstructure were roughly designed for the PC footbridges. A deck girder footbridge with hollow post-tension concrete beams was selected after considering multiple viewpoints, including economy, workability, structure, view, and maintenance. The following Table shows the model cases of the PC footbridge. CASE-1 is the base case with two types of corrosive protected cases added. CASE-2 adopts epoxy resin coated reinforcing bar and PC tendon. CASE-3 also adopts coated bar and tendon, with the addition of a paint coating on the concrete surface. The calculated initial cost of each superstructure is: 48,240,000JPY, 50,620,000JPY and 54,370,000JPY respectively. As regards the substructure, two piers (Pier 1 and Pier 2) were roughly designed for each of three alternatives. The best results are shown in the following Table. The total cost of the substructure was 10,130,000JPY.

The initial cost of FRP bridges is roughly divided into three categories: (1) materials, (2) assembly, and (3) mold for hand lay-up. Table 3 shows the initial cost of FRP bridges. The initial cost of the FRP superstructure was 73,600,000JPY. The base model case (CASE-4) of the FRP footbridge has some special points, for example, it is the first real FRP footbridge in Japan and it is located on the seashore, suggesting that it may be possible to reduce its initial cost. We considered a modified case (CASE-5) for FRP bridges so as to reduce its initial cost. These modifications were: (1) change of handrail to aluminum, (2) change of design in the joint part of main girders, and (3) sharing of mold by two bridges. The result of the modified initial cost became 62,350,000JPY.

Table : Model cases of PC bridges and initial costs

(Unit: 1000JPY)

	CASE-1	CASE-2	CASE-3
Corrosion protection for the superstructure	None	Coated reinforcing bars Coated PC tendon	Coated reinforcing bars Coated PC tendon Surface coating
Initial cost for the superstructure	48,240	50,620	54,370
Substructure system	Pier 1: 6 Steel pipe piles (φ600mm-9mm, L=17.5m)		
	Pier 2: 4 Steel pipe piles (φ600mm-12mm, L=20.0m)		
Initial cost for the substructure	10,130		
Total Initial costs	58,370	60,750	64,500

Table : Model cases of FRP bridges and initial costs

(Unit: 1000JPY)

	CASE-4	CASE-5
Modified points for the superstructure	Standard FRP bridge based on the real bridge	(1) Aluminum handrail (2) Change of joint parts of the main girders (3) Sharing the mold by 2 bridges
Initial cost for the superstructure	73,600	62,350
Substructure system	Pier 1: 2 Steel pipe piles (φ500mm-9mm, L=15.0m)	
	Pier 2: 4 Steel pipe piles (φ500mm-9mm, L=18.0m)	
	Pier 3: 2 Steel pipe piles (φ500mm-9mm, L=12.0m)	
Initial cost for the substructure	6,910	
Total Initial costs	80,510	69,260

There are three piers (Pier 1, Pier 2, and Pier 3) for the substructure of the FRP footbridge. When comparing the two pile systems, driven steel pipe piles and PHC (Pretension Spun High Strength Concrete) piles with installation by inner excavation, the steel pipe piles substructure showed better results in this case.

Comparing the total costs including both the superstructure and substructure, the difference of the initial cost of the modified FRP footbridge (69,260,000JPY) was only 10% higher than the initial cost of the corrosion protected PC footbridge. This result suggests FRP bridges have significant competitive power even when considering the initial cost.

## Maintenance costs

### PC footbridge

Inspection and repair are the main maintenance considerations for bridges. We considered only the repair cost. The costs for inspection were omitted because it seems there are not large differences in the inspection of PC and FRP bridges.

For the PC bridges, it is estimated that the penetration of chloride ion into the concrete after the construction, and the repair was set when the concentration of chloride ion at steel reinforcing bars



reached 1.2 kg/m<sup>3</sup>. Replacement of covering concrete and surface coating was selected as the repair method for the PC bridges. The life of the surface coating which protects against chloride ion penetration was set at 15 years and 30 years, and repair of the surface coating was calculated in these intervals. The following Table shows the results of the repair costs.

### FRP footbridge

Since the Okinawa Road Park Bridge is relatively new, there is not enough information on its repair and maintenance requirements. However, five years after its construction, stainless steel bolts were replaced because of corrosion due to the severely corrosive environment. This amounted to 1,000,000JPY. We therefore considered the same scale of repair may be required at the same interval within a severely corrosive environment and the repair cost was also modified by adopting highly durable bolts. The cost is 3,500,000JPY and the repair interval was set at 40 to 50 years.

Repainting is the major repair concern for FRP footbridges. There will be no corrosion for FRP structures caused by weak points of painting such as edges or bolt parts like a painted steel structure because FRP does not corrode. Hence, we set the repainting interval based on the decrease of thickness caused by the deterioration of the painting material. The repainting interval was set at about 120 years based on the thickness (75  $\mu$ m) and the material (fluorine resin paint) of the paint. The repainting cost was calculated and the result was 5,600,000JPY including the scaffolding for repainting.

### LCC

The following Table shows the results of initial cost, maintenance cost and LCC for both PC and FRP footbridges. At 50 years, LCC of the FRP footbridge was 90,510,000JPY; this is lower than the 50-year LCC of the PC footbridge without corrosion protection. The lowest 50-year LCC was that of the PC footbridge with epoxy resin coated reinforcing bar and PC tendon (CASE-2). However, the modified FRP footbridge (CASE-5) showed the lowest 100-year LCC among our five cases. These results suggest that FRP footbridges are more efficient when longer life is required in severely corrosive environments.

The Table shows the results of initial cost, maintenance cost and LCC for both PC and FRP footbridges. At 50 years, LCC of the FRP footbridge was 90,510,000JPY; this is lower than the 50-year LCC of the PC footbridge without corrosion protection. The lowest 50-year LCC was that of the PC footbridge with epoxy resin coated reinforcing bar and PC tendon (CASE-2). However, the modified FRP footbridge (CASE-5) showed the lowest 100-year LCC among our five cases. These results suggest that FRP footbridges are more efficient when longer life is required in severely corrosive environments.

Table : LCC results of both PC and FRP footbridges

(Unit: 1000JPY)

	CASE-1	CASE-2	CASE-3		CASE-4	CASE-5
			Repair interval: 15 years	Repair interval: 30 years		
Initial cost for super-structures	48,240	50,620	54,370		73,600	62,350
Initial cost for sub-structures	10,130	10,130	10,130		6,910	6,910
Total the initial costs	58,370	60,750	64,500		80,510	69,260
Maintenance cost for 30 years	24,500	0	18,000	9,000	6,000	3,500

Maintenance cost for 50 years	42,500	0	27,000	9,000	10,000	3,500
Maintenance cost for 100 years	69,500	24,500	54,000	27,000	20,000	7,000
50 years LCC	100,870	60,750	91,500	73,500	90,510	72,760
100 years LCC	127,870	85,250	118,500	91,500	100,510	76,260

## 5. CONCLUSION

Here we calculated the LCC of FRP and PC footbridges, faithfully considering actual conditions based on a real FRP footbridge constructed in Japan. The result suggests that FRP bridges has a competitive edge over other types of construction in spite of its initial cost and that FRP footbridges are more efficient when longer life is required in severely corrosive environments.

### Illustration 3 :

'O' Ltd. is about to replace its old boiler equipment, either by a coal-fired system or by an oil-fired system. Finance costs 10% a year, and other estimated costs are as follows:

(₹ in '000)

Particulars	Coal	Oil
Initial cost of boiler	70	100
Annual operating costs	60 p.a	45 p.a.

If the company expected the new boiler system to last at least 10 years, which system should be chosen?

### Solution:

On the basis of initial cost only, the company would choose coal. But coal's lifetime costs are much higher than oils as we can see when we include the discounted annual operating costs of each system:

(₹ in '000)

Particulars	Coal	Oil
Initial cost of boiler	70	100
Annual operating costs*	368	276
Total life cycle costs	438	376

\*Annual costs X 6.144

On this basis, oil is clearly much cheaper than coal. Unless there are other overriding considerations favoring coal, oil fired Boiler should be chosen.

If the decision seemed closer, it might be useful to try sensitivity analysis. How much would fuel costs need to change to alter the decision? What difference would it make if the life were much shorter (or much longer) than 10 years? What if the discount rate were significantly different from 10% a year?

**Illustration 4**

S & C Ltd. is about to replace its rapidly deteriorating boiler equipment. Three types of boiler system are being considered as a suitable replacement:

**A.** Coal-fired, **B.** Gas-fired, and **C.** Oil-fired.

The associated costs are as follows:

(₹ in '000)

Boiler system	A	B	C
Cost of boiler (including installation and commissioning)	550	740	640
Annual Fuel cost	270	230	250
Annual operating labour costs	80	-	-
Annual maintenance cost	40	30	30
Annual Electricity cost	10	10	10
Total Operating Cost	400	270	290

The new boiler system is expected to last at least 10 years. The Company has an opportunity cost of finance of 10% per year. Which system should be chosen?

**Solution:**

If the decision is taken on the basis of initial cost only, then the coal-fired boiler system would be selected. However, over its life time (at least ten years) the annual operating costs are much higher than for the gas-fired and oil-fired systems. The life cycle costs for ten years are as follows:

(₹ in '000)

Boiler System	A	B	C
Cost of boiler	550	740	640
Operating costs (Annual costs X 10)	4,000	2,700	2,900
	4,550	3,440	3,540

However, we need to discount the annual costs at a 10% discount rate to arrive at the present value cost of each system. The discount factor for year 1-10 at 10% is 6.144.

**The present value of each system then is:**

(₹ In'000)

Boiler System	A	B	C
Cost of Boiler	550	740	640
Operating Costs (Annual Costs x 6.144)	2,458	1,659	1,782
Present Value of Costs	3,008	2,399	2,422

On the basis of financial considerations only, the gas-fired system is the most economical. Unless there are other important considerations the gas-fired system should be chosen. A more intricate analysis might attempt to forecast the likely changes in each of the annual operating costs (e.g., fuel costs, maintenance costs, etc.). It might be useful, to see how much each of the three fuel costs would need to change to alter the decision. In addition to looking at the importance of fuel costs to the decision, we can also check the sensitivity of the expected system life. For instance, if the expected life is reduced to five years, the oil-fired system (C) becomes the most economical, as follows :



(₹ in '000)

Particulars	A	B	C
Cost of boiler	550	740	640
Operating costs (Annual costs X 3.791)	1516	1,024	1,099
Present value of costs	2,066	1,764	1,739

If the expected life is reckoned to be six years or more, the decision is in favour of the gas-fired system.

### Illustration 5

IGF Ltd. supports the concept of the terotechnology or life cycle costing for new investment decisions covering its engineering activities.

The company is to replace a number of its machines and the Production Manager is to run between the 'X' machine, a more expensive machine with a life of 12 years, and the 'W' machine with an estimated life of 6 years. If the 'W' machines chosen it is likely that it would be replaced at the end of 6 years by another 'W' machine. The pattern of maintenance and running costs differs between the two types of machine and relevant data are shown below:

(₹ in '000)

Particulars	X	Y
Purchase Price	7,600	5,200
Trade in Value	1,200	1,200
Annual Repair Costs	800	1,040
Overhaul costs (p.a.)	1,600	800
Estimated Financing Costs averaged over machine life (p.a.)	10%	10%

You are required to recommend, with supporting figures, which machine to purchase, stating any assumptions made.

### Solution:

#### Machine X- Life 12 years

Particulars	Year	Cost (₹)	Discount factor	Discounted cost
Purchase Price	0	7,600	1.00	7,600
Overhaul Cost	8	1,600	0.47	752
Trade in value	12	(1,200)	0.32	(384)
Annual Repair Cost	1-12	800	6.81	5,448
				13,416

**Annualized Equivalent Cost:** ₹ 13,416/6.81 = ₹ 1,970

#### Machine W - Life 16 years

Particulars	Year	Cost (₹)	Discount factor	Discounted cost
Purchase Price	0	5,200	1.00	5,200
Overhaul Cost	4	800	0.68	544
Trade in value	6	(1,200)	0.56	(672)
Annual Repair Cost	1-6	1,040	4.36	4,534
				9,606

**Annualized Equivalent Cost:** ₹ 9,606/4.36 = ₹ 2,203

**Recommendation:** Purchase Machine 'X' Assumptions:

- Same performance, capacity and speed.
- No inflation.
- 12 year-estimates are as accurate as 6-year estimates.
- Cash flow at the year end.

### Illustration 6

A housewife is looking at ways of producing domestic hot water and considers two possibilities an electric immersion heater having an installation cost of ₹ 160 and estimated annual electrical charges of ₹ 200, and a gas boiler with an installation cost of ₹ 760 with annual fuel bills of ₹ 80.

Assuming yourself as a consultant to this cost-conscious-housewife, advice her suitably by comparing two systems, on the basis of (i) total expenditure, and (ii) present value, over a 5-years period. Take interest at 9 per cent.

What will be your recommendation if you consider both the equipments for an 8 years period?

### Solution:

The total cost consists of the Installation cost plus electrical charges for 5 years.

(i) So total cost for Electric immersion heater = ₹160 + ₹ 200 X 5 = 1,160

(ii) Total cost for a gas boiler = ₹ 760 + ₹ 80 X 5 = 1,160

Hence, on the total cost basis, both the equipments have equal preference, and the housewife can choose any one. Let us now calculate the present value of money for each of the two possibilities.

Year	PV factor @ 9% P.a.	Electric Immersion Heater		Gas Boiler	
		Operating Cost (₹)	Discounted Cost (₹)	Operating Cost (₹)	Discounted Cost (₹)
0	1.000	160	160.00	760	760.00
1	0.9174	200	183.48	80	73.39
2	0.8417	200	168.34	80	67.33
3	0.7722	200	154.44	80	61.78
4	0.7084	200	141.68	80	56.67
5	0.6499	200	129.98	80	51.99
		Total cost = 937.92 (₹ 938, say)		Total cost = 1071.16 (₹ 1071 say)	

On the basis of present value @ 9% p.a. over a period of five years, total cost of Electric Immersion heater is ₹ 938 and that of Gas Boiler is ₹ 1071. Hence, the house wife is advised to purchase an electric immersion heater.

If the equipment are to be considered for a period of 8 years, then

Total Cost for electric immersion heater	₹160 + 200 x 8 =	₹ 1,760
Total Cost of Gas Boiler	₹ 760 + 80 x 8 =	₹ 1,400

Hence, the house wife will be advised to purchase a gas boiler.

Year	PV factor @ 9% P.a.	Electric Immersion Heater		Gas Boiler	
		Operating Cost (₹)	Discounted Cost (₹)	Operating Cost (₹)	Discounted Cost (₹)
6	0.5963	200	119.26	80	47.70
7	0.5470	200	109.40	80	43.76
8	0.5019	200	100.38	80	40.15
		Total cost = 329.04 (₹ 329 say)		Total cost = 131.61 (₹ 132 say)	

Present Value in case of electric immersion heater

P.V. over five years + P.V. over next three years = ₹ 938 + ₹ 329 = ₹ 1,267

Present Value in case of Gas Boiler = ₹ 1,071 + ₹ 132 = ₹ 1,203

Hence, over an 8 years period, the present value of a gas boiler is less

On the basis of total cost as well as present value of money, gas boiler is cheaper over 8 year's period; hence the housewife is advised to purchase a gas boiler.

#### Illustration 7:

A machine used on a production line must be replaced at least every four years. The costs incurred in running the machine according to its age are:

(₹)

Particulars	Age of Machine (Years)				
	0	1	2	3	4
Purchase Price	3,000				
Maintenance	-	800	900	1,000	1,000
Repairs	-	-	200	400	800
Net Realizable Value	-	1,600	1,200	800	400

Future replacement will be identical machines with the same costs. Revenue is unaffected by the age of the machine. Assume there is no inflation and ignore tax. The cost of capital is 15%. Determine the optimum replacement cycle.

Present value factors at 15% for years 1, 2, 3 and 4 are 0.8696, 0.7561, 0.6575 and 0.5718 respectively. Present value of annuity at 15% for years 1, 2, 3 and 4 are 0.8696, 1.6257, 2.2832 and 2.8550 respectively.

**Solution:**

The possible replacement options of the machine are every one, two, three & four years.

The annual equivalent cost of each of these replacement policies are as follows:

**Replacement every year**

(₹)

Particulars	Year	
Cost	(3,000)	-
Maintenance	-	(800)
Resale Value	-	1,600
<b>Total</b>	<b>(3,000)</b>	<b>800</b>
DCF	1.000	0.8696
Present Value of cash flows	(3,000)	696
Total PV of costs	= ₹ 2,304	
Annual Equivalent costs	$\frac{2,304}{0.8696} = ₹ 2,649$	

**Replacement every 2 year**

(₹)

Particulars	Year		
	0	1	2
Cost	(3,000)	-	-
Maintenance	-	(800)	(900)
Repairs	-	-	(200)
Resale Value	-	-	1,200
<b>Total</b>	<b>(3,000)</b>	<b>(800)</b>	<b>100</b>
DCF @ 1%	1.000	0.8696	0.7561
Present Value of cash flows	(3,000)	(696)	76
Total PV of costs	= ₹ 3,620		
Annual Equivalent costs	$= \frac{3,620}{1.6257} = ₹ 2,227$		

**Replacement every 3 year**

(₹)

Particulars	Year			
	0	1	2	3
Cost	(3,000)	-	-	-
Maintenance	-	(800)	(900)	(1,000)
Repairs	-	-	(200)	(400)
Resale Value	-	-	-	800
<b>Total</b>	<b>(3,000)</b>	<b>(800)</b>	<b>(1,100)</b>	<b>(600)</b>
DCF @ 1%	1.000	0.8696	0.7561	0.6575
Present Value of cash flows	(3,000)	(696)	(832)	(395)
Total PV of costs	= ₹ 4,923			
Annual Equivalent costs	$= \frac{4,923}{2.2832} = ₹ 2,156$			



### Replacement every 4 year

(₹)

Particulars	Year				
	0	1	2	3	4
Cost	(3,000)	-	-	-	-
Maintenance		(800)	(900)	(1,000)	(1,000)
Repairs	-	-	(200)	(400)	(800)
Resale Value	-	-	-	-	400
<b>Total</b>	<b>(3,000)</b>	<b>(800)</b>	<b>(1,100)</b>	<b>(1,400)</b>	<b>(1,400)</b>
DCF @ 1%	1.000	0.8696	0.7561	0.6575	0.5718
Present Value of cash flows	(3,000)	(696)	(832)	(921)	(800)
Total PV of costs				= ₹ 6,249	
Annual Equivalent costs				= $\frac{6,249}{2.8550} = ₹ 2,189$	

### Illustration 8 :

Company has to replace one of its machines which has become unserviceable. Two options are available:

- I. A more expensive machine (EM) with 12 years of life;
- II. A less expensive machine (LM) with 6 years of life.

If machine LM is chosen, it will be replaced at the end of 6 years by another LM machine. The pattern of maintenance, running costs and prices are as under:-

Particulars	EM (₹)	LM (₹)
Purchase Price	10,00,000	7,00,000
Scrap value at the end of life	1,50,000	1,50,000
Overhauling is due at the end of	8 <sup>th</sup> year	4 <sup>th</sup> year
Overhauling costs	2,00,000	1,00,000
Annual Repairs	1,00,000	1,40,000

Cost of Capital – 14%

You are required to recommend with supporting calculations which of the machines should be purchased.

End of 4 <sup>th</sup> year	0.5921
End of 6 <sup>th</sup> year	0.4556
End of 8 <sup>th</sup> year	0.3506
End of 12 <sup>th</sup> year	0.2076
Years 1-6	3.8890
Year 1-12	5.660

### Solution:

Machine EM – 12 year Life

Particulars	Year	Cost (₹)	Disc. factor	Present Value(₹)
Purchase Price	0	10,00,000	1.000	10,00,000
Overhauling Costs	8	2,00,000	0.3506	70,120
Annual Repairs	1-12	1,00,000	5.6600	5,66,000
Scrap Value	12	1,50,000	0.2076	(31,140)
Total NPV of Outflows				16,04,980



Machine LM – 6 year Life

Particulars	Year	Cost (₹)	Disc. factor	Present Value(₹)
Purchase Price	0	7,00,000	1.000	7,00,000
Overhauling Costs	4	1,00,000	0.5921	59,210
Annual Repairs	1-6	1,40,000	3.8890	5,44,460
Scrap Value	6	1,50,000	0.4556	(68,340)
Total NPV of Outflows				12,35,330

**Annualized value:**

Name of Machine	Calculation	Amount (₹)
EM	16,04,980/5.660	= ₹ 2,83,565
LM	12,35,330/3.889	= ₹ 3,17,647

Hence, EM is recommended.

**Illustration 9**

A company is considering a cost saving project. This involves purchasing a machine costing ₹ 7,000, which will result in annual savings on wage costs of ₹ 1,000 and on material costs of ₹ 400.

The following forecasts are made of the rates of inflation each year for the next 5 years

Wages Cost	10%
Material Cost	5%
General prices	6%

The cost of capital of the company, in monetary terms is 15%.

Evaluate the projects, assuming that the machine has a life of 5 years and no scrap value.

**Solution:**

Calculation of net present value

Year	Labour cost Saving (₹)	Material Cost Saving (₹)	Total savings (₹)	Dcf @ 15%	Present Value (₹)
1	$1,000 \times (1.1) = 1,100$	$400 \times (1.05) = 420$	1,520	0.870	1,322
2.	$1,000 \times (1.1)^2 = 1,210$	$400 \times (1.05)^2 = 441$	1,651	0.756	1,248
3.	$1,000 \times (1.1)^3 = 1,331$	$400 \times (1.05)^3 = 463$	1,794	0.658	1,180
4.	$1,000 \times (1.1)^4 = 1,464$	$400 \times (1.05)^4 = 486$	1,950	0.572	1,115
5.	$1,000 \times (1.1)^5 = 1,610$	$400 \times (1.05)^5 = 510$	2,120	0.497	1,054
Present value of total savings					5,919
Less: Initial cash outflow					7,000
N.P.V(negative)					(-) 1,081

## 3.5 LEAN MANAGEMENT & PROCESS MAPPING

### 3.5.1 Lean Management

Lean management has been developed with the intention of reducing process wastes and maximizing the value of the product or the service to the customer. This is achieved through unique techniques like flow charts, total productive maintenance, just in time techniques, workplace redesigning techniques, and total quality management. Lean management is an important part of lean thinking. As we implement lean in any organization the traditional way of managing does not guarantee right focus nor help sustaining lean initiatives. If no action is taken to change the way we manage process, people and products we are likely to see failure of lean implementations. Many people on lean journey fail to apply lean in a holistic manner. Without proper guidance and leadership the company cannot move to the next level. Thus a management system that specifically meets the needs of a transforming organization is very much essential.

Lean is all about customer focus. Value is defined by the customer and we develop and maintain processes to provide this value. Processes are run by people. Only support and proper leadership and guidance can drive your people to continuously improve the processes that add value to the customer. The management system that helps you to achieve this is a Lean Management system. Lean Management system uses various tools to connect the purpose (Providing value to customer) to the process and people. Some of the lean management tools which are commonly used are Leader standard work, visual control boards, and daily accountability.

The tools itself are not effective unless used with right mindset. There is a lot of work needed to be done at individual level for the managers to become lean managers. To start with lean management we have to start developing managers in to “Lean Managers”.

#### 3.5.1.1 Principles of Lean

The five-step thought process for guiding the implementation of lean techniques is easy to remember, but not always easy to achieve:

1. Specify value from the standpoint of the end customer by product family.
2. Identify all the steps in the value stream for each product family, eliminating whenever possible those steps that do not create value.
3. Make the value-creating steps occur in tight sequence so the product will flow smoothly toward the customer.
4. As flow is introduced, let customers pull value from the next upstream activity.
5. As value is specified, value streams are identified, wasted steps are removed, and flow and pull are introduced, begin the process again and continue it until a state of perfection is reached in which perfect value is created with no waste.

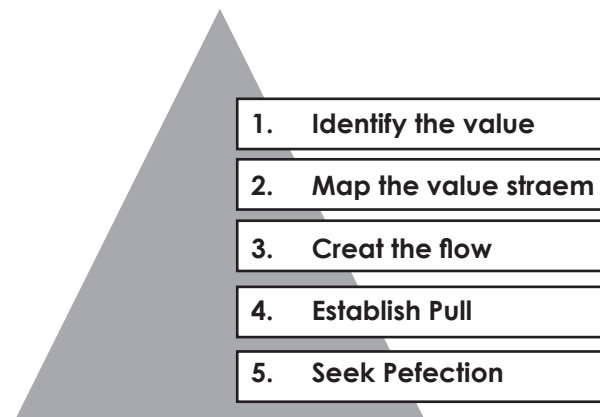

### 3.5.1.2 Benefits of Lean Management

“Lean manufacturing is a management philosophy that pursues the continuous elimination of waste in all business processes through kaizen, also known as small and incremental improvement.”

Many of us are familiar with this common definition of Lean. While it is certainly accurate, we often find that the specific benefits that Lean will have on individual processes and eventually entire companies are seldom discussed. While it makes sense that the elimination of waste will result in more efficient operations. Here we explore what is achieved after much waste has been eliminated from a shop floor, notably *single piece flow*.

Single Piece Flow:

Single piece flow can be described as an ideal state of efficient operations, where batch sizes and lost production are replaced by working on one product at a time. While not practical for operations which are having very low processing times and correspondingly high change-over times (both values defined by take time), it is nevertheless a Lean Manufacturing goal to achieve single piece flow in every operation possible.

Achieving one-piece flow requires the elimination of the following wastes.

1. Labour
2. Overproduction
3. Space
4. Defects
5. Unnecessary human motion
6. Inventory
7. Transportation

As a company reduces these wastes and strives for single piece flow, many other benefits will follow. Some of these benefits include (1) improved quality and fewer defects (2) reduced inventory (3) less space required to build product, (4) enhancement to overall manufacturing flexibility, (5) identification of future kaizen workshops, (6) ensures a safer work environment and (7) improves employee morale. We will review each of these benefits in more detail:

**(1) Improved quality and fewer defects:** When batching and lot production are eliminated, there is less opportunity to manufacture defects. Since the batch size will be just 1, there will not be mountains of inventory to count, move, store and pick.

Furthermore, single piece flow ensures that if there is a quality problem, we know that the defect has affected only that single part. We do not need to dedicate hours isolating and testing other material in the same production run to determine if it meets quality standards.

Of course, if a defect is caught in a single piece flow environment, this should not mean that we do not take the appropriate corrective actions to ensure that the problem will not reoccur. In this case, the manager or supervisor must determine if standard work was followed and if so, what changes need to be made to the standard in order to ensure that the problem will never resurface again.

**(2) Reduced Inventory:** Implementing single piece flow will require each operation to only produce what is needed by the next operation (in Lean jargon, we call this individual the *surgeon*). When followed properly, the process will eliminate any opportunity to build ahead. Consequently, inventories will not be allowed to build up.

**(3) Requires less space:** As inventory levels are reduced, less space and manpower will be required to manage (receive, count, stock, store, pick and deliver) it. In addition, single piece flow usually



results in manufacturing cells which squeeze machines close together so that a single operator can oversee many pieces of equipment with the least amount of walking motion.

- (4) **Enhances overall manufacturing flexibility:** We know from our value stream maps that the less inventory in a value stream, the shorter the lead-time will be from customer order to product delivery. In a single piece flow environment, since we operate with less inventory, lead-times will also drop, thereby giving us more time to react to customer orders (unless the strategic decision is made to pass off the lead-time gains to the customer in order to beat competitors!).
- (5) **Makes identifying future Kaizen simpler:** We have already discussed that in a single piece flow environment, defects and WIP inventories fall. As this happens, the shop floor will open up and it will become easier to see production problems. For example, if a particular process cannot keep up with take time and WIP is not allowed to be incurred, it will quickly become apparent to even the casual observer that something is wrong. In this case, it will be easy to decide where to focus the next improvement activity.
- (6) **Ensures a safer work environment:** Less inventory means less clutter, more light in the darkest corners of the factory and the opportunity to better lay out equipment and tools. Also, since manufacturing cells are occupied by a set number of employees who each know their repeating tasks (as defined by standard work), there is less opportunity for unexpected movements, which increase the chances of accidents.
- (7) **Improves employee morale:** Since single piece flow results in production problems being identified and (hopefully) solved right away, team members will receive immediate feedback on their work. This in turn will give everybody more ownership in their production area. Also, provided they lead problem solving efforts by focusing on processes and not individuals, more trust will be gained in managers.

#### 3.5.1.3 Issues Addressed by Lean Management

In any organization, the following five major problems are being addressed when **lean management** is being implemented:

1. **Low Productivity.** In the general sense, productivity means volume. It may be the number of calls handled in a call center, the number of products manufactured in a factory, the number of transactions resolved in a support group. Whatever kind of productivity it is, implementing **lean management** will help increase yields; enabling the organization to generate more satisfied customers and higher profit.
2. **Prolonged Cycle Time.** A complaint resolved beyond timeline gives birth to another complaint. It is integral for the organization to manage the handling time to any problem for resolution. Shorter cycle times not cycle lates must be delivered.
3. **Costly Organization.** Organizational expense must be carefully allotted to where it must be. Profit and Loss management must be clearly defined. Even if you have an increasing customer base but your company expenses are also increasing, you will not achieve a favorable cost report. You can reduce cost by maximizing the talents and saving resources.
4. **Rampant Wastage.** Time, resources, manpower, and cost are all subject to be wasted if not managed properly. Reducing or eliminating **wastes** will aid an organization to focus on the critical few. Focusing on essential things will create more room for improvement.
5. **Dissatisfied Customers and Employees.** The heart of the organization is in the employees and the soul is the customers. Companies must always have a program called "WOCAS" or What Our Customers Are Saying. It is also vital to capture the voice of the workforce via regular town hall cascades or focus group discussions.

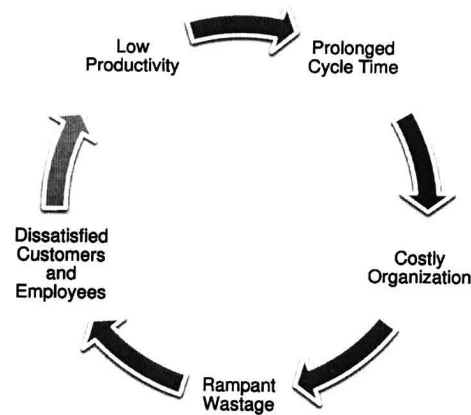

### 3.5.1.4 Lean Management Major Stakeholders

Practice of lean management principle targets three major stakeholders; Customers, Employees, and the Organization:

1. **Customers.** Nothing is more rewarding if we see our customers delighted. The delight may be due to the satisfaction to the product or may be because of an encompassing customer service. It's a cliché but, customers are always right. And even if they are not, they have to always feel that they are valued. All concerns and issues must be addressed upfront. Avoid false promises. Value added services are always a catcher preventing loss or decline in the number of customers.
2. **Employees.** This is the workforce. The rank and file level. They are the organization's wheelbarrow. A happy employee will merit a delighted customer. An employee who is well compensated, whose professional directions are defined, and who are empowered will surely make a star organization.
3. **Organization.** The organization is the board members, the CEO, and the business owners. The organization is also the processes, the house rules, and other implementations. They are the fuel of the company. An organization that is well managed, balanced and not biased, has heart for the customers are but model organizations these days. They are the echo of the **lean management** system.



### Advocates of Lean Management

When it comes to businesses, lean management is never selective. Any type of business; be it manufacturing, operations, customer service, and other types can adapt the principles of lean management. As long as the goal coincides with what lean management is teaching, applying lean management will never be a problem.



There is also no SPOC or single point of contact that everybody will rely on. Applying lean management must be a collaborative effort among departments, teams, and groups. Business improvements must not be focused to one department alone. At the end of the day, all groups must provide inputs on how to better performance, increase profit, reduce waste, and implement excellent processes.

### **3.5.2 Process Mapping**

Process mapping is a workflow diagram to bring forth a clearer understanding of a process or series of parallel processes.

Most organizations that want to move “up a notch” are process mapping using one or more of the following: Deming's Total Quality Management model, International Standard Organization criteria, Goldratt's Theory of Constraints, Baldrige Criteria for Excellence, or the Balanced Score Card.

#### **3.5.2.1 Constructing a Process Flowchart**

##### **Step 1: Determine the Boundaries**

1. Where does a process begin?
2. Where does a process end?

##### **Step 2: List the Steps**

1. Use a verb to start the task description.
2. The flowchart can either show the sufficient information to understand the general process flow or detail every finite action and decision point.

##### **Step 3: Sequence the Steps**

1. Use post-it notes so you can move tasks.
2. Do not draw arrows until later.

##### **Step 4: Draw Appropriate Symbols**

###### **Start with the basic symbols:**

1. Ovals show input to start the process or output at the end of the process.
2. Boxes or rectangles show task or activity performed in the process.
3. Arrows show process direction flow.
4. Diamonds show points in the process where a yes/no questions are asked or a decision is required.
5. Usually there is only one arrow out of an activity box. If there is more than one arrow, you may need a decision diamond.
6. If there are feedback arrows, make sure feedback loop is closed; i.e. it should take you back to the input box.

##### **Step 5: System Model**

1. Draw charts using system model approach.
2. Input - use information based upon people, machines, material, method, and environment.
3. Process - use subsets of processes in series or parallel.
4. Output - use outcomes or desired results.
5. Control - use best in class business rules.
6. Feedback - use information from surveys or feedback.

### **Step 6: Check for Completeness**

1. Include pertinent chart information, using title and date for easy reference.

### **Step 7: Finalize the Flowchart**

1. Ask if this process is being run the way it should be.
2. Are people following the process as charted?
3. Do we have a consensus?
4. What is redundant; add what is missing.

The purpose of process mapping is to use diagramming to understand the process we currently use and ask what is expected of us; what should we be doing to provide better customer focus and satisfaction. It will identify what best practices we need to incorporate and find appropriate benchmarks for measuring how we can arrive at better ways of communicating our services. As Dr. George Washington Carver put it – **“It is simply service that measures success.”**

#### **3.5.2.2 Importance:**

- ❖ It provides an opportunity to learn about Work that is being performed.
- ❖ Dr. Myron Tribes said
  - ✓ You don't learn to Process Map
  - ✓ You Process Map to learn.
- ❖ Most processes today are Undocumented

#### **3.5.2.3 Process Maps are used to**

- ❖ Document processes.
  - ✓ Provide a reference to discuss how things get done.
  - ✓ Describe and understand the work we do.
- ❖ Analyze and improve on processes.
  - ✓ Identify of areas of complexity and re-work.
  - ✓ To generate ideas for improvement.
  - ✓ Illustrate process improvements.

### 3.5.2.4 Symbols used to Process Map

- **Start & End:** An **oval** is used to show the materials, information or action (inputs) to start the process or to show the results at the end (output) of the process.



- **Activity:** A **box or rectangle** is used to show a task or activity performed in the process. Although multiple arrows may come into each box, usually only one arrow leaves each box.



- **Decision:** A **diamond** shows those points in the process where a yes/no question is being asked or a decision is required.



- **Break:** A **circle** with either a letter or a number identifies a break in the process map and is continued elsewhere on the same page or another page.





A pictorial representation of Process Map given below:

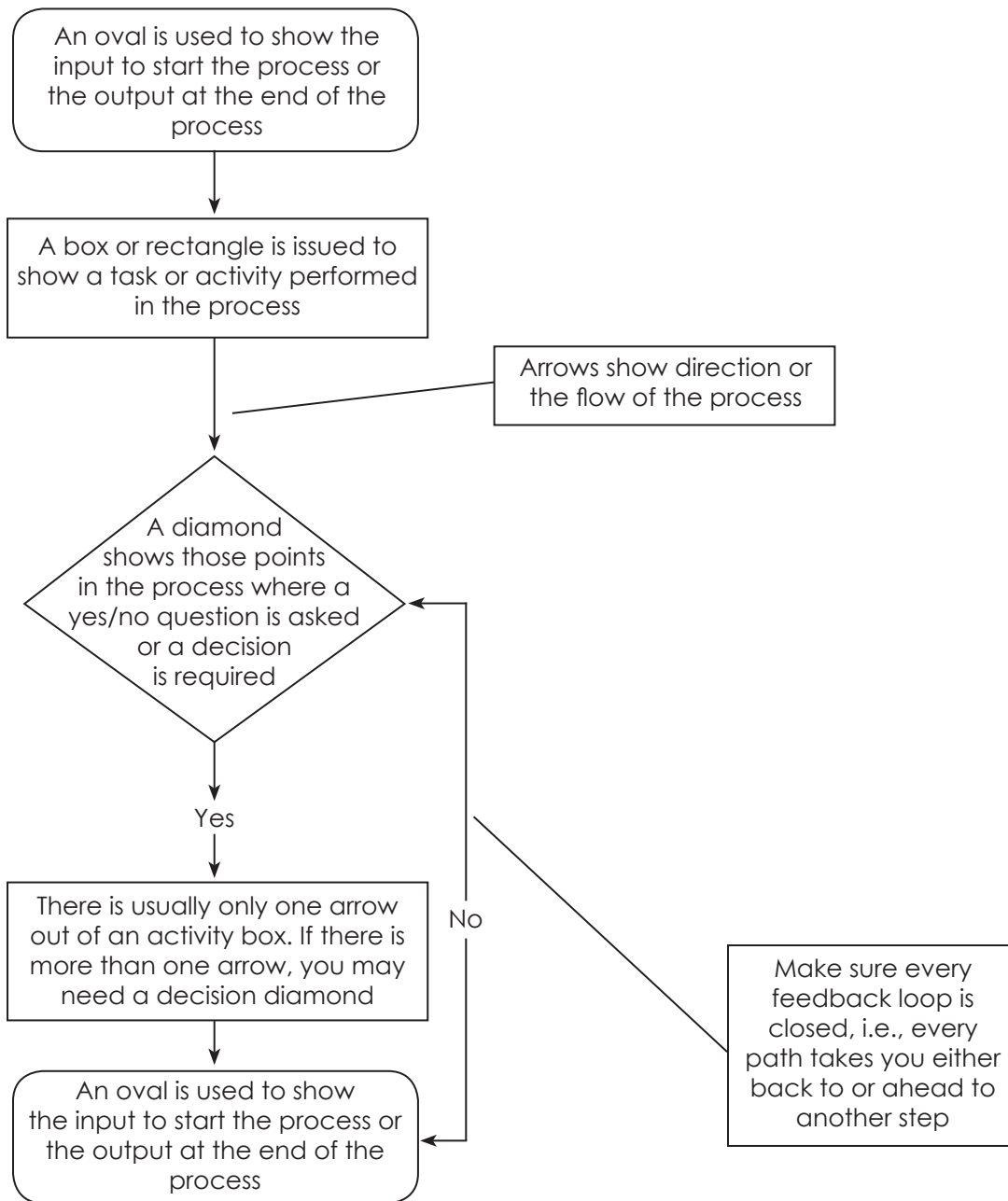

# Study Note - 4

## STRATEGIC REASONING AND DECISION ANALYSIS



### This Study Note includes

#### 4.1 Game Theory (Normal Form and Extensive Form)

#### 4.2 Decision Trees

#### 4.3 Attitude towards Risk

#### 4.4 Expected Value of Perfect Information

### 4.1 GAME THEORY (NORMAL FORM AND EXTENSIVE FORM)

Game theory is the branch of decision theory concerned with interdependent decisions. It is a body of knowledge which is concerned with the study of decision making in situation where two or more rational opponents are involved under condition of competition and conflicting interests. It deals with human processes in which an individual decision making unit is not in complete control of the other decision making units. Here unit may be an individual group, organisation, society or a country.

Game Theory is a type of decision theory which is based on reasoning in which the choice of action is determined after considering the possible alternatives available to the opponents playing the same game. The aim is to choose the best course of action, because every player has got an alternative course of action.

Because game theory arose from the analysis of competitive scenarios, the problems are called games and the participants are called players. But these techniques apply to more than just sport, and are not even limited to competitive situations. In short, game theory deals with any problem in which each player's strategy depends on what the other players do.

Situations involving interdependent decisions arise frequently, in all walks of life. A few examples in which game theory could come in handy include:

- Friends choosing where to go have dinner
- Parents trying to get children to behave
- Commuters deciding how to go to work
- Businesses competing in a market
- Diplomats negotiating a treaty
- Gamblers betting in a card game

All of these situations call for strategic thinking - making use of available information to devise the best plan to achieve one's objectives.

In a game there are number of possible outcomes, with different values to the decision makers. They might have some control but do not have the complete control over others example - players in a chess game, labour union striking against the management, companies striving for larger share of market etc are the situations where theory of games is applicable because each situation can be viewed as games. So, game theory is important weapon in the hands of management. Game theory is a scientific approach rational decision making.

**Assumptions or rules of the game theory are as follows:**

- i. Each players has a finite set of possible courses of action or strategies.
- ii. Players act rationally.
- iii. Players attempt to maximize gain and minimize losses.
- iv. All types of relevant informations are known in advance.
- v. Players to adopt individual decisions without any direct communication.
- vi. The payoff is fixed and known in advance.
- vii. Player A's gains are player B's losses and vice versa.

**4.1.1 Basic Terminology**

**Strategy:** A strategy for a player has been defined as a set of rules or alternative courses of action available to him in advance, by which player decides the course of action that he should adopt. Strategy may be of two types:

**Pure Strategy:** If the players select the same strategy each time, then it is referred to as pure-strategy. In this case each player knows exactly what the other is going to do *i.e.*, there is a deterministic situation and the objective of the players is to maximize gains or to minimize losses.

**Mixed Strategy:** When the players use a combination of strategies and each player always kept guessing as to which course of action is to be selected by the other player at a particular occasion then this is known as mixed-strategy. Thus, there is a probabilistic situation and objective of the player is to maximize expected gains or to minimize losses. Thus mixed strategy is a selection among pure strategies with fixed probabilities.

**Optimal strategies:** A course of action or play which puts the player in the most preferred position, irrespective of the strategy of his competitors is called an optimal strategy. Any deviation from this strategy results in a decreased pay-off for the player.

**Value of the game:** It is the maximum guaranteed gain to the maximising player if both the players use their best strategy. It refers to the average pay off per play of the game over a period of time.

**Two Person Zero-Sum Game:** Two person zero-sum game is the situation which involves two persons or players and gains made by one person is equals to the loss incurred by the other. For example there are two companies Coca-cola & Pepsi and are struggling for a larger share in the market. Now any share of the market gained by the Coca-cola company must be the lost share of Pepsi, and therefore, the sums of the gains and losses equals zero. In other words if gain of Coca-cola is 40% so the lost share of the Pepsi will be 40%. The sum of game and losses is zero *i.e.*  $(+40\%) + (-40\%) = 0$ .

There are two types of two-person zero-sum games. In one, the most preferred position is achieved by adopting a single strategy and therefore the game is known as the *pure strategy game*. The second type requires the adoption by both players a combination of different strategies in order to achieve the most preferred position and is, therefore, referred to as the *mixed strategy game*.

**Payoff matrix:** In a game, the gains and losses, resulting from different moves and counter moves, when represented in the form of a matrix are known as payoff matrix or gain matrix.

This matrix shows how much payment is to be made or received at the end of the game in case a particular strategy is adopted by a player. Payoff matrix shows the gains and losses of one of the two players, who is indicated on the left hand side of the pay off matrix. Negative entries in the matrix indicate losses. This is generally prepared for the maximising player. However the same matrix can be interpreted for the other player also, as in a zero sum game, the gains of one player represent the losses of the other player, and vice versa. Thus, the payoff matrix of Mr. A is the negative pay off matrix for Mr.B. The other player is known as the minimising player. He is indicated on the top of the table.

Let A and B be two business men engaged in same business. It is obvious that there will be a competition between them regarding the business. As a result there are some conflicts of interest between A and B. In his case, in mathematical terminology the business is known as game and the businessmen A and B are known as players of the game. Suppose A can adopt one of the  $m$  policies  $A_1, A_2, \dots, A_m$  and B can adopt one of the  $n$  policies  $B_1, B_2, \dots, B_n$  to control their respective business. The restriction imposed in the game is that each player can adopt only one policy at a time. The adoption of a policy by a player is known as a strategy (or move) taken by the player. The selection of a strategy by a player depends on the previous strategies adopted by him. The strategy that is taken by a player ignoring the strategy taken by the opponent is known as a pure strategy. We shall consider here only the **pure strategies**. When there is a competition between two players then one of the players is assumed to be in a better position to control the business. That player is known as **maximizing players** and the other player is known as **minimizing player**.

In a two-person zero-sum game, it is assumed that each player known the outcome i.e., gain or loss, of all possible pure strategies taken by him and his opponent during a play of the game. The gain or loss for all possible combinations of strategies taken by A and his opponent B is expressed in form of a matrix which is known as **pay-off matrix of B**. Each element of a pay-off matrix is known as **pay-off number**. A pay-off number  $a_{ij}$  in pay-off matrix of A represents the gain or loss of A.

		Player A		
		$B_1$	$B_2$	$B_3$
Player A	$A_1$	2	-1	0
	$A_2$	1	3	-2

We interpret the table as below :

		Strategy of B		
		$B_1$	$B_2$	$B_3$
Strategy of A	$A_1$	A gain 2 units	A losses 1 unit	None gains
	$A_2$	A gains 1 units	A gains 3 units	A losses 2 units

In the above pay-off matrix of A, A is called the *row player* and B is called the *column player*. The pay-off matrix of B will be just negative of the above pay-off matrix of A and in that case B will be the *row player* and A will be the *column player*.

### THE MAXIMIN-MINIMAX PRINCIPLE

- (i) **Maximin Criteria:** The maximising player lists his minimum gains from each strategy and selects the strategy which gives the maximum out of these minimum gains.
- (ii) **Minimax Criteria :** The minimising player lists his maximum loss from each strategy and selects the strategy which gives him the minimum loss out of these maximum losses.

For Example Consider a two person zero sum game involving the set of pure strategy for Maximising player A say  $A_1, A_2$  &  $A_3$  and for player B,  $B_1$  &  $B_2$ , with the following payoff

		Player B		
		B1	B2	Row minima
Player A	A1	9	2	2
	A2	8	6	6 * Maximin
Column Maxima	A3	6	4	4
		9	6 * Minimax	

Since Maximin = Minimax

$$V = 6$$

Suppose that player A starts the game knowing fully well that whatever strategy he adopts B will select that particular counter strategy which will minimise the payoff to A. If A selects the strategy  $A_1$  then B will select  $B_2$  so that A may get minimum gain. Similarly if A chooses  $A_2$  then B will adopt the strategy of  $B_2$ . Naturally A would like to maximise his maximin gain which is just the largest of row minima. Which is called 'maximin strategy'. Similarly B will minimise his minimum loss which is called 'minimax strategy'. We observe that in the above example, the maximum of row minima and minimum of column maxima are equal. In symbols.

$$\text{Maxi [Min.]} = \text{Mini [Max]}$$

The strategies followed by both the players are called 'optimum strategy'.

**Saddle Point**

The Saddle point in a pay off matrix is one which is the smallest value in its row and the largest value in its column. The saddle point is also known as equilibrium point in the theory of games. An element of a matrix that is simultaneously minimum of the row in which it occurs and the maximum of the column in which it occurs is a saddle point of the matrix game.

In a game having a saddle point optimum strategy for a player X is always to play the row containing saddle point and for a player Y to play the column that contains saddle point. The following steps are required to find out Saddle point;

- (i) Select the minimum value of each row & put a circle around it.
- (ii) Select the maximum value of each column and put square around it.
- (iii) The value with both circle & square is the saddle point.

In case there are more than one Saddle point there exist as many optimum points or solutions of the game. There may or may not be the saddle point in the game. When there is no saddle point we have to use algebraic methods for working out the solutions concerning the game problem.

Saddle point can be found out in different ways.

Player A	Player B	
	$B_1$	$B_2$
$A_1$	20	80
$A_2$	40	30
$A_3$	50	60

**1st Method**

Step 1. Putting circle ○ around Row minima.

Step 2. Putting square □ around Column Maxima.

Step 3. Saddle point is a point where circle & square □○ are both combined.

		$B_1$	$B_2$
Player A	$A_1$	(20)	(80)
	$A_2$	40	(30)
	$A_3$	(50)	60

Value of game =  $V = 50$

## 2nd Method

- (i) Putting mark\* on each Row minima.
- (ii) Putting mark\* on each Column Maxima.
- (iii) Saddle point where both\* and (different star) appears.

		B <sub>1</sub>	B <sub>2</sub>
Player A	A <sub>1</sub>	20*	80*
	A <sub>2</sub>	40	30*
	A <sub>3</sub>	50**	60

Value of game = (v) = 50

## 3rd Method

- (i) Creating column for minimum value of each row
- (ii) Creating Row for Maximum value of each column.

		B <sub>1</sub>	B <sub>2</sub>	Row Minima
A <sub>1</sub>	20	80	20	
A <sub>2</sub>	40	30	30	
A <sub>3</sub>	50	60	50* Maximum	
Column Maxima	50*	80	Minimax	

The same value in Row minima & Column maxima is the value of game. The optimal strategy for A is A<sub>3</sub> and for B is B<sub>1</sub>  
(Students can apply any method they like.)

### 4.1.2 Rule of Dominance

This rule is applicable to a zero-sum game between two persons, with any number of strategies. For a pay-off matrix of large size, the rule of dominance can be applied to reduce the size by carefully eliminating rows and/or column prior to final analysis to determine the optimum strategy selection for each person.

In general the following rules are adopted :

- (i) In a pay-off matrix if all the elements of any row (say ith) are less than or equal to (i.e.,  $\leq$ ) the corresponding elements of any other row (say jth), then the ith strategy is dominated by jth row; in other words the player (or person) A will ignore or reject the ith row. Thus the pay-off matrix is reduced.
- (ii) In a pay-off matrix if all the elements of any column (say rth) are greater than or equal to (i.e.,  $\geq$ ) the corresponding elements of any other column (say sth) then the rth strategy is dominated by s-th strategy; in other words the player B will ignore or reject the r-th strategy, hence again the pay-off matrix is reduced.
- (iii) A pure strategy may be dominated if it is inferior to the average of two or more other pure strategies.

### 4.1.3 Limitations of the Game Theory

Our discussion of game theory has been restricted to the two-person zero-sum games. There are practically no applications of game theory to the real world situations. This is because of the assumptions underlying the theory.

The game model that is based on the assumption that each of the individuals involved not only acts rationally but preference ordering of the outcomes is determined by the order of magnitudes of their associated pay-offs, but also he assumes that the opponent is also rational in that sense. Besides, it is also assumed that both the players are having complete and equal knowledge about the strategies available to them and the resulting pay-offs. It can easily be visualized that in real world situations, 'tis only but rarely that each of the persons would have complete knowledge about all the strategies available to his competitor, as also of the exact pay-off values associated with various combinations of strategies.

The two-person zero sum game is not a true picture of business environment and is quite unrealistic for the following reason:

In real world situation there will not only be two person or teams competing but there could be a number of them.

Complete information about the competitors and moves is not possible in all real life problems.

The loss of one person is not necessarily the gain of the other at all times.

### 4.1.4 Two-Person Zero-Sum Games and Their Solution

As stated earlier, a two-person zero-sum game is the one which involves two persons (players) and where the gain made by one equals the loss incurred by the other. To illustrate, suppose that there are two firms A and B which, for a long period in the past, have been selling a competing product and are now engaged in struggle for a larger share of the market. Now with the total market of a given size, any share of the market gained by one firm must be lost by the other, and, therefore, the sum of the gains and losses equals zero.

Let us assume that both these firms are considering the same three strategies in a bid to gain the share in the market; low advertising, high advertising, and quality improvement. We assume also that currently they are sharing the market equally and further that each of the firms can employ only one of the strategies at a time.

Under the conditions postulated, there are a total of  $3 \times 3 = 9$  combinations of the moves possible—thus, low advertising by firm A may be accompanied by low advertising, high advertising or quality improvement by B and so on for other strategies. Each pair of the moves shall affect the sharing of the market in a particular way. For example, low advertising both by firm A and by firm B shall lead to 12 points (implying 12 per cent of the total market) in favour of firm A, while low advertising by A and high advertising by B would lead to a shift of 8 points in favour of B. Similarly, there are pay-offs corresponding to other pairs of moves. These are shown in the pay-off matrix that follows. The strategies of low advertising, high advertising and quality improvement have been marked as  $a_1$ ,  $a_2$ , and  $a_3$ , respectively for the firm A, and  $b_1$ ,  $b_2$  and  $b_3$ , respectively for the firm B.

		B's Strategy		
		$b_1$	$b_2$	$b_3$
A's Strategy	$a_1$	12	6	-2
	$a_2$	6	7	3
	$a_3$	-10	-6	2

This pay-off matrix is drawn from A's point of view—a positive pay-off indicates that the firm A has gained the market share at the expense of firm B while negative pay-offs imply B's gain at A's expense.

Now the problem before us is to determine the best strategy for A and B, assuming that they both are acquainted with the information contained in the pay-off matrix and that each one is not aware of the move the other is likely to take. The conservative approach to the selection of the best strategy would call for a cautious attitude of assuming the worst and acting accordingly. In reference to the pay-off matrix, if firm A employs strategy  $a_1$ , it would expect the firm B to employ strategy  $b_2$ , thereby reducing A's pay-off from the strategy  $a_1$  to its minimum pie, equal to - 8, representing a loss to firm A. If firm A employs strategy  $a_2$ , it would assume the competing firm would employ strategy  $b_3$  that would give A a 3 per cent increase in the share of market. Similarly, corresponding its strategy  $a_3$ , firm A would expect the firm B to use  $b_1$ , which puts the firm A at a loss of 10 points.

The firm A would like to make the best use of the situation by choosing the maximum of these minimal pay-offs. Obviously, among the three alternate strategies open to it, firm A would choose the one which would maximise the minimum rewards associated with these. This decision rule of selection is called the maximin strategy. Since the minimal pay-offs corresponding to  $a_1$ ,  $a_2$ , and  $a_3$  are, respectively, - 8, 3, and - 10, firm A would select  $a_2$  as its strategy.

Similarly, the firm B would also employ a cautious approach in choosing its strategy. When firm B adopts  $b_1$ , it can expect firm A to employ  $a_1$  which would ensure it (firm A) the maximum advantage. In a similar way adoption of  $b_2$  and  $b_3$  would, in firm B's expectation, be associated with employment of  $a_2$ . To minimise the advantage accruing to A, the firm would select a strategy that would yield the least advantage to its competitor i.e. the strategy  $b_3$ . The decision of B is said to be in accordance with the minimax strategy.

It may be noted that corresponding to maximin rule of firm A and the minimax rule of firm B, the pay-off is 3. This amount is the worth, or the value, of the game,  $V$ , and represents the final pay-off to the winning player by the losing player. Since the pay-off matrix is drawn from A's point of view, if the value of game is positive, as is in the present case, it is favourable to A while if the game value is negative, the game is favourable to B. The game is said to be fair or equitable if its value is equal to zero, for then it favours none.

### Illustration 1

Two leading firms, Sunirmala Textiles Ltd. and Mati Sayons Ltd., for years have been selling shirting which is but a small part of both firms' total sales. The Marketing Director of Sunirmala Textiles raised the question, "What should the firm's strategies be in terms of advertising for the product in question?" The system group of Sunirmala Textiles developed the following data for varying degrees of advertising:

- No advertising, medium advertising and heavy advertising for both firms will result in equal market share.
- Sunirmala Textiles with no advertising: 40 per cent of the market with medium advertising by Mati Sayons and 28 percent of the market with heavy advertising by Mati Sayons.
- Sunirmala Textiles using medium advertising: 70 per cent of the market with no advertising by Mati Sayons and 45 per cent of the market with heavy advertising by Mati Sayons.
- Sunirmala Textiles using heavy advertising: 75 per cent of the market with no advertising by Mati Sayons and 52.5 per cent of the market with medium advertising by Mati Sayons.

Based upon the above information, answer the marketing director's question.

### Solution:

The pay-off matrix from the viewpoint of Sunirmala Textiles Ltd., showing its market share under several combinations of the strategies, is given below. Also, row minima and column maxima have been obtained to see if saddle point exists.



			Mati Sayons Ltd.'s Strategy			Row Minima
			No Advt $b_1$	Med. Advt. $b_2$	Hvy. Advt $b_3$	
Sunirmala Textile Ltd.'s Strategy	No. Advt. $a_1$	50	40	28	28	
	Med. Advt. $a_2$	70	50	45	45	
	Hvy. Advt. $a_3$	75	52.5	50	50*	
Column Maxima		75	52.5	50*		

We observe that saddle point exists at the intersection of  $a_3$  and  $b_3$ . Thus, the optimal strategy for each one is to engage in heavy advertising and it will result in an even distribution of the market between the firms. Sunirmala Textiles Ltd's marketing director should, therefore, resort to heavy advertising.

#### 4.1.6 When No Saddle Point Exists

We have considered game situations which have a saddle point(s) and observed that in such cases we are provided with an adequate theory of how best to play the game. It is possible that there is no saddle point of a game and so it is not possible to find its solution in terms of the pure strategies—the maximin and the minimax Games without saddle points are not strictly determined. The solution to such problems calls for employing mixed strategies. A mixed strategy represents a combination of two or more strategies that are selected one at a time, according to pre-determined probabilities. Thus, in employing a mixed strategy, a player decides to mix his choices among several alternatives in a certain ratio. Now we shall discuss the determination of mixed strategy—first for the 2 x 2 games and then for problems of higher order. An example follows:

#### Illustration 2

The following is the pay-off matrix of a game being played by A and B. Determine the optimal strategies for the players and the value of the game.

		B's Strategy	
		$b_1$	$b_2$
A's Strategy	$a_1$	8	-7
	$a_2$	-6	4

#### Solution:

This given problem does not have a saddle point. Therefore, the method discussed before does not suffice to enable us to determine optimal ways for A and B to play. If A plays  $a_1$  then B would play  $b_2$  while for  $a_2$  played by A, B would choose to play  $b_1$ . So if B knows what choice A will make then B can ensure that he gains by choosing a strategy opposite to the one desired by A. Thus, it is of utmost importance for A to make it difficult for B to guess as to what choice he is going to make. Similarly, B would like to make it very difficult for A to assess the strategy he is likely to adopt. It would pay each one of them to play either of the respective strategies open to each with certain probability.

Now suppose that A plays strategy  $a_1$  with probability  $x$  and plays strategy  $a_2$  with probability  $1 - x$ . If B plays strategy  $b_1$ , then A's expected pay-off can be determined in reference to the figures given in the first column of the pay-off matrix as follows:

$$\text{Expected pay-off (given that B plays } b_1) = 8x - 6(1 - x)$$

Similarly, if B plays strategy  $b_2$ , the expected payoff of A can be determined as follows:

$$\text{Expected pay-off (given that B plays } b_2) = -7x + 4(1 - x)$$

Now we shall determine a value of  $x$  so that the expected pay-off for A is the same irrespective of the strategy adopted by B. This value can be obtained by equating these two equations.



Thus,  $8x - 6(1 - x) = -7x + 4(1 - x)$

or,  $8x - 6 + 6x = -7x + 4 - 4x$

or,  $x = 10/25 = 2/5.$

A would do best to adopt the strategies  $a_1$  and  $a_2$ , choosing in a random manner, in the proportion 2:3 (i.e. 2/5 and 3/5). The expected pay-off for A using this mixed strategy equals

$$8 \times (2/5) - 6(3/5) = -2/5$$

or,  $-7(2/5) + 4(3/5) = -2/5$

Thus, he shall net a loss of 2/5 per play in the long run.

We can determine mixed strategy for B in a similar manner as for A. Thus, if he plays strategy  $b_1$  with probability  $y$  and strategy  $b_2$  with probability  $1 - y$ , we have

Expected pay-off (given that A plays  $a_1$ ) =  $8y - 7(1 - y)$ , or,

Expected pay-off (given that A plays  $a_2$ ) =  $-6y + 4(1 - y)$

We can determine the value of  $y$  as will ensure equal pay-off irrespective of the strategy of A, as follows:

$$8y - 7(1 - y) = -6y + 4(1 - y)$$

or,  $8y - 7 + 7y = -6y + 4 - 4y$

or,

$$y = 11/25$$

Thus, B should play strategies  $b_1$ , and  $b_2$  in the ratio of 11 : 14 in a random manner,

B's expected pay-off (loss) per play shall be:

$$8(11/25) - 7(14/25) = -10/25 = -2/5$$

$$-6(11/25) + 4(14/25) = -10/25 = -2/5$$

It implies that B shall gain 2/5 per play in the long run.

Thus, we conclude that A and B should both use mixed strategies as given here and the value of game equals -2/5.

	Strategy	Probability
For A,	$a_1$	2/5
	$a_2$	3/5
For B,	$b_1$	11/25
	$b_2$	14/25

In general, for a zero-sum two-persons game in which each of the players, say A and B, have strategies  $a_1$  &  $a_2$  and  $b_1$  &  $b_2$  respectively, and the pay-offs as given below then, if  $x$  is the probability with which A chooses strategy  $a_1$  and if  $y$  is the probability that B plays strategy  $b_1$  we have,

		B's Strategy	
		$b_1$	$b_2$
A's Strategy	$a_1$	$a_{11}$	$a_{12}$
	$a_2$	$a_{21}$	$a_{22}$

$$X = \frac{a_{22} - a_{21}}{(a_{11} + a_{22}) - (a_{12} + a_{21})}; y = \frac{a_{22} - a_{12}}{(a_{11} + a_{22}) - (a_{12} + a_{21})}$$

$$V = \frac{a_{11}a_{22} - a_{12}a_{21}}{(a_{11} + a_{22}) - (a_{12} + a_{21})}$$

For the Example,  $a_{11} = 8, a_{12} = -7, a_{21} = -6,$  and  $a_{22} = 4.$  Substituting these values in the formulae, we get

$$X = \frac{4 - (-6)}{(8 + 4) - (-7 - 6)} = \frac{10}{25} = \frac{2}{5}$$

$$Y = \frac{4 - (-7)}{(8 + 4) - (-7 - 6)} = \frac{11}{25};$$

$$V = \frac{8 \times 4 - (-7)(-6)}{(8 + 4) - (-7 - 6)} = \frac{-10}{25} = \frac{-2}{5}$$

These values match with the ones already obtained

Below, we explain how to solve the game theory (a pictorial presentation)

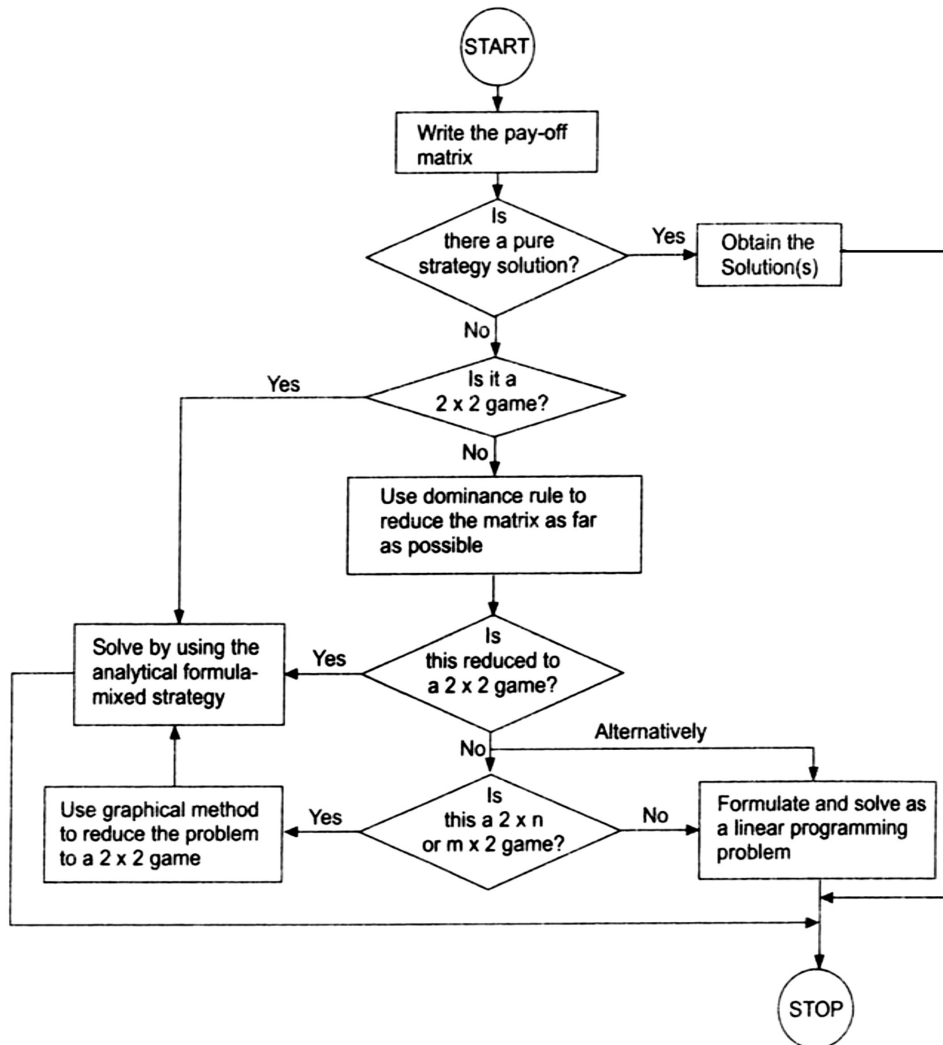



### Illustration 3

For the following game, find optimal strategies of A and B and value of game using principle of dominance :

		Player B			
		B <sub>1</sub>	B <sub>2</sub>	B <sub>3</sub>	B <sub>4</sub>
Player A	Strategies				
	A <sub>1</sub>	7	6	8	9
	A <sub>2</sub>	-4	-3	9	10
	A <sub>3</sub>	3	0	4	2
A <sub>4</sub>	10	5	-2	0	

### Solution

Comparing strategies A<sub>1</sub> and A<sub>3</sub>, A<sub>1</sub> gives more gain than A<sub>3</sub> in all conditions (for all strategies of B), A<sub>1</sub> dominates over A<sub>3</sub>. Hence we can ignore A<sub>3</sub> and the effective pay off matrix shall be as shown below:

		Player B			
		B <sub>1</sub>	B <sub>2</sub>	B <sub>3</sub>	B <sub>4</sub>
Player A	Strategies				
	A <sub>1</sub>	7	6	8	9
	A <sub>2</sub>	-4	-3	9	10
	A <sub>4</sub>	10	5	-2	0

In this above reduced matrix B<sub>3</sub> is dominating B<sub>4</sub>, so B<sub>4</sub> is redundant and ignoring this, the effective payoff matrix will be :

		Player B			Row minimum
		B <sub>1</sub>	B <sub>2</sub>	B <sub>3</sub>	
Player A	Strategies				
	A <sub>1</sub>	7	6	8	6
	A <sub>2</sub>	-4	-3	9	-4
A <sub>4</sub>	10	5	-2	-2	
Column Maximum		10	6	9	

Hence we find that the saddle point exist and As optimal strategy is A<sub>1</sub> whereas B's optimal strategy will be B<sub>2</sub> and value of game is ₹6. It implies that A cannot gain more than ₹6 and B cannot reduce his loss below ₹6 in the case.

### 4.1.7 SOLUTION OF $m \times n$ GAMES—FORMULATION AND SOLUTION AS AN LPP

We have already stated that a game can also be formulated and solved as a linear programming problem. We shall illustrate this formulation by considering a simple 3x3 pay-off matrix. Here each of the players A and B has three strategies and pay-offs corresponding to various combinations of the strategies of the players represented by  $a_{11}$ ,  $a_{12}$ , etc.

		B's Strategy		
		B <sub>1</sub>	B <sub>2</sub>	B <sub>3</sub>
A's Strategy	A <sub>1</sub>	$a_{11}$	$a_{12}$	$a_{13}$
	A <sub>2</sub>	$a_{21}$	$a_{22}$	$a_{23}$
	A <sub>3</sub>	$a_{31}$	$a_{32}$	$a_{33}$

A is interested in maximising the minimum gain that can be obtained by playing this game. The objective, then, is to maximise the minimum value of the game  $U$  subject to the constraints that regardless of the alternative that B chooses, the expected pay-off shall be at least equal to  $U$ . Now, let  $x_1, x_2$  and  $x_3$  be the probabilities with which A plays the strategies  $A_1, A_2$ , and  $A_3$ ; let  $E_1$  be the expected pay-off of A when he plays the three strategies with these probabilities and B decides  $B_1$ ; Similarly let  $E_2$  and  $E_3$  be the expected pay-offs associated with the strategies  $B_2$  and  $B_3$  respectively, adopted by B.

$$E_1 = a_{11} x_1 + a_{21} x_2 + a_{31} x_3$$

$$E_2 = a_{12} x_1 + a_{22} x_2 + a_{32} x_3$$

$$E_3 = a_{13} x_1 + a_{23} x_2 + a_{33} x_3$$

We can now express the problem as

Maximise  $U$  (i.e. maximise the minimum value  $U$ )

Subject to

$$a_{11}x_1 + a_{21}x_2 + a_{31}x_3 \geq U \quad (\text{i.e. } E_1)$$

$$a_{12}x_1 + a_{22}x_2 + a_{32}x_3 \geq U \quad (\text{i.e. } E_2)$$

$$a_{13}x_1 + a_{23}x_2 + a_{33}x_3 \geq U \quad (\text{i.e. } E_3)$$

$$\text{and} \quad x_1 + x_2 + x_3 = 1$$

Assuming that  $U$  is positive (which it, in any case, would be if all the pay-offs,  $a_{ij}$ 's, are positive), we can divide all the constraints by  $U$  and attempt to minimise  $1/U$  rather than maximise  $U$ . For this, we define a new variable set  $X_i = x_i/U$  and restate the problem completely as a linear programming problem, as follows:

$$\text{Minimise} \quad \frac{1}{U} = X_1 + X_2 + X_3$$

Subject to

$$a_{11}X_1 + a_{21}X_2 + a_{31}X_3 \geq 1$$

$$a_{12}X_1 + a_{22}X_2 + a_{32}X_3 \geq 1$$

$$a_{13}X_1 + a_{23}X_2 + a_{33}X_3 \geq 1$$

$$X_1, X_2, X_3 \geq 0$$

Looking from B's point of view, it is easy to visualize that his problem is to minimise,  $V$ , the maximum loss that he is to incur by playing this game. B's problem can be interpreted as the dual to the linear programming model obtained above in respect of A. Also, we can derive it directly from the information given.

It follows.

Let  $y_1, y_2$ , and  $y_3$  be the probabilities with which B plays strategies  $B_1, B_2$  and  $B_3$ , respectively and  $E'_1, E'_2$  and  $E'_3$  be the expected pay-offs associated with the events that A chooses, respectively,  $A_1, A_2$ , and  $A_3$  while B plays the strategies  $B_1, B_2$  and  $B_3$  with the given probabilities. Accordingly,

$$E'_1 = a_{11}y_1 + a_{12}y_2 + a_{13}y_3,$$

$$E'_2 = a_{21}y_1 + a_{22}y_2 + a_{23}y_3,$$

$$E'_3 = a_{31}y_1 + a_{32}y_2 + a_{33}y_3,$$

Now, the problem is to minimise  $V$ , subject to

$$a_{11}y_1 + a_{12}y_2 + a_{13}y_3 \geq 1$$

$$a_{21}y_1 + a_{22}y_2 + a_{23}y_3 \geq 1$$

$$a_{31}y_1 + a_{32}y_2 + a_{33}y_3 \geq 1$$

$$y_1, y_2, y_3 \geq 0$$

and

If we define (assuming as before that V is positive)  $Y_i = y_i/V$ , and divide all constraints by V, we can express the LPP as follows:

$$\begin{aligned} &\text{Maximise} && \frac{1}{V} = Y_1 + Y_2 + Y_3 \\ &\text{Subject to} && \\ &&& a_{11}Y_1 + a_{12}Y_2 + a_{13}Y_3 \leq 1 \\ &&& a_{21}Y_1 + a_{22}Y_2 + a_{23}Y_3 \leq 1 \\ &&& a_{31}Y_1 + a_{32}Y_2 + a_{33}Y_3 \leq 1 \\ &&& Y_1, Y_2, Y_3 \geq 0 \end{aligned}$$

This, clearly, is the dual of the LPP given earlier.

We have stated that U and V should be positive. In cases where some  $a_{ij}$ 's are negative, U and V may not be positive. In such cases, a constant is added to all the entries in the pay-off matrix as will ensure that each of them would become positive. After this, the problem is solved in usual manner and then the objective function is adjusted by subtracting that constant from it, which is the required answer.

#### Illustration 4

Formulate the following game as an LPP and obtain its solution:

		B's Strategy		
		$b_1$	$b_2$	$b_3$
A's Strategy	$a_1$	8	9	3
	$a_2$	2	5	6
	$a_3$	4	1	7

#### Solution :

The given problem can be formulated as an LPP from A's and B's point of view as follows: Let  $x_1, x_2,$  and  $x_3$  be the probabilities with which A chooses respectively the strategies  $a_1, a_2$  and  $a_3$ ;  $y_1, y_2,$  and  $y_3$  be the probabilities in respect of B choosing  $b_1, b_2,$  and  $b_3$ .

From A's point of view, we have to

$$\begin{aligned} &\text{Minimise} && \frac{1}{U} = X_1 + X_2 + X_3 \\ &\text{Subject to} && \\ &&& a_{11}X_1 + a_{21}X_2 + a_{31}X_3 \geq 1 \\ &&& a_{12}X_1 + a_{22}X_2 + a_{32}X_3 \geq 1 \\ &&& a_{13}X_1 + a_{23}X_2 + a_{33}X_3 \geq 1 \\ &&& X_1, X_2, X_3 \geq 0 \end{aligned}$$

where U represents the value of the game, and  $X_i = x_i/U$ . We have to determine the values of U,  $x_1, x_2$  and  $x_3$ . Thus, the problem is

$$\begin{aligned} &\text{Minimise} && \frac{1}{U} = X_1 + X_2 + X_3 \\ &\text{Subject to} && \\ &&& 8X_1 + 2X_2 + 4X_3 \geq 1 \\ &&& 9X_1 + 5X_2 + X_3 \geq 1 \\ &&& 3X_1 + 6X_2 + 7X_3 \geq 1 \\ &&& X_1, X_2, X_3 \geq 0 \end{aligned}$$

From B's point of view, we have to

Maximise  $\frac{1}{V} = Y_1 + Y_2 + Y_3$   
 Subject to

$$a_{11}Y_1 + a_{12}Y_2 + a_{13}Y_3 \leq 1$$

$$a_{21}Y_1 + a_{22}Y_2 + a_{23}Y_3 \leq 1$$

$$a_{31}Y_1 + a_{32}Y_2 + a_{33}Y_3 \leq 1$$

$$Y_1, Y_2, Y_3 \geq 0$$

Where V is the game value and  $Y_i = y_i/V$ .

Thus, the LPP is

Maximise  $\frac{1}{V} = Y_1 + Y_2 + Y_3$   
 Subject to

$$8Y_1 + 9Y_2 + 3Y_3 \leq 1$$

$$2Y_1 + 5Y_2 + 6Y_3 \leq 1$$

$$4Y_1 + Y_2 + 7Y_3 \leq 1$$

$$Y_1, Y_2, Y_3 \geq 0$$

To obtain the required values we can solve either of these LPPs, and read the solution of the other from it as each one is the dual of the other. We shall solve the game from B's point of view.

Introducing the slack variables, we have

Maximise  $\frac{1}{V} = Y_1 + Y_2 + Y_3 + 0S_1 + 0S_2 + 0S_3$   
 Subject to

$$8Y_1 + 9Y_2 + 3Y_3 + S_1 = 1$$

$$2Y_1 + 5Y_2 + 6Y_3 + S_2 = 1$$

$$4Y_1 + Y_2 + 7Y_3 + S_3 = 1$$

$$Y_i \geq 0, S_i \geq 0, i = 1, 2, 3$$

Resolution is contained in the following tables.

Simplex Tableau 1: Non-optimal Solution

Basis		$Y_1$	$Y_2$	$Y_2$	$S_1$	$S_2$	$S_3$	$b_i$	$b_i/a_{ij}$
$S_1$	0	8*	9	3	1	0	0	1	1/8 ← Outgoing
$S_2$	0	2	5	6	0	1	0	1	1/2 variable
$S_3$	0	4	1	7	0	0	1	1	1/4
$C_j$		1	1	1	0	0	0		
Solution		0	0	0	1	1	1		
$\Delta_j$		1	1	1	0	0	0		
		↑							
		Incoming variable							



Simplex Tableau 2: Non-optimal Solution

Basis		Y <sub>1</sub>	Y <sub>2</sub>	Y <sub>2</sub>	S <sub>1</sub>	S <sub>2</sub>	S <sub>3</sub>	b <sub>i</sub>	b <sub>i</sub> /a <sub>ij</sub>
Y <sub>1</sub>	1	1	9/8	3/8	1/8	0	0	1/8	1/3
S <sub>2</sub>	0	0	11/4	21/4	-1/4	1	0	3/4	1/7
S <sub>3</sub>	0	0	-7/2	11/2*	-1/2	0	1	1/2	1/11 ← Outgoing variable
C <sub>j</sub>		1	1	1	0	0	0		
Solution		1/8	0	0	0	3/4	1/2		
Δ <sub>j</sub>		0	-1/8	5/8	-1/8	0	0		
				↑ Incoming variable					

Simplex Tableau 3: Non-optimal Solution

Basis		Y <sub>1</sub>	Y <sub>2</sub>	Y <sub>3</sub>	S <sub>3</sub>	S <sub>2</sub>	S <sub>3</sub>	b <sub>i</sub>	b <sub>i</sub> /a <sub>ij</sub>
Y <sub>1</sub>	1	1	15/11	0	7/44	0	-3/44	1/11	1/15
S <sub>2</sub>	0	0	67/11*	0	5/22	1	-21/22	3/11	3/67
Y <sub>3</sub>	1	0	-7/11	1	-1/11	0	2/11	1/11	1/67 ← Outgoing variable
C <sub>j</sub>		1	1	1	0	0	0		
Solution		1/11	0	1/11	0	3/11	0		
Δ <sub>j</sub>		0	3/11	0	-3/44	0	-5/44		
				↑ Incoming variable					

Simplex Tableau 4: Optimal Solution

Basis		Y <sub>1</sub>	Y <sub>2</sub>	Y <sub>3</sub>	S <sub>1</sub>	S <sub>2</sub>	S <sub>3</sub>	b <sub>i</sub> /a <sub>ij</sub>	
Y <sub>1</sub>	1	1	0	0	29/268	-15/67	39/268	2/67	
Y <sub>2</sub>	1	0	1	0	5/134	11/67	-21/134	3/67	
Y <sub>3</sub>	1	0	0	1	-9/134	7/67	11/134	8/67	
C <sub>j</sub>		1	1	1	0	0	0		
Solution		2/67	3/67	8/67	0	0	0		
Δ <sub>j</sub>		0	0	0	-21/268	-12/268	-19/268		

Substituting the values of Y<sub>1</sub>, Y<sub>2</sub> and Y<sub>3</sub> in the objective function, we have,

$$\frac{1}{V} = \frac{2}{67} + \frac{3}{67} + \frac{8}{67} = \frac{13}{67}$$

Therefore V, the game value = 67/13.

Since Y<sub>i</sub> = y<sub>i</sub>/V, we have y<sub>i</sub> = Y<sub>i</sub> × V. Thus,

$$y_1 = \frac{2}{67} \times \frac{67}{13} = \frac{2}{13}; y_2 = \frac{3}{67} \times \frac{67}{13} = \frac{3}{13}; \text{ and } y_3 = \frac{8}{67} \times \frac{67}{13} = \frac{8}{13}$$

We can read the values of the dual variables X<sub>1</sub>, X<sub>2</sub> and X<sub>3</sub> from the Δ<sub>j</sub> row of the Table 4. These are respectively, 21/268, 12/268, and 19/268. From these,

$$\frac{1}{U} = \frac{21}{268} + \frac{12}{268} + \frac{19}{268} = \frac{52}{268} = \frac{13}{67}$$



Thus,  $U = 67/13$  (same as shown earlier).

Now, we have

$$x_1 = \frac{21}{268} \times \frac{67}{13} = \frac{21}{52}; x_2 = \frac{12}{268} \times \frac{67}{13} = \frac{12}{52}; \text{ and } x_3 = \frac{19}{268} \times \frac{67}{13} = \frac{19}{52}$$

Thus, the optimal strategy for, A is  $(21/52, 12/52, 19/52)$ ; for B it is  $(2/13, 3/13, 8/13)$  while the game value is  $67/13$ .

**Illustration 5**

Solve the following game:

		B's Strategy		
		B <sub>1</sub>	B <sub>2</sub>	B <sub>3</sub>
A's Strategy	A <sub>1</sub>	3	4	- 2
	A <sub>2</sub>	- 3	0	1
	A <sub>3</sub>	- 1	- 4	2

**Solution :**

Since some of the entries in the pay-off matrix are negative, we shall add a constant to each of the values to convert them all into positive values. Adding 5 to each of them, we get the following revised pay-off matrix:

		B's Strategy		
		B <sub>1</sub>	B <sub>2</sub>	B <sub>3</sub>
A's Strategy	A <sub>1</sub>	8	9	3
	A <sub>2</sub>	2	5	6
	A <sub>3</sub>	4	1	7

This problem now is the same as Illustration 4, for which we have the value of the game equal to  $67/13$ . Since a constant 5 was added to each of the pay-offs, we shall subtract this value from  $67/13$  to obtain  $2/13$  which is the value of the game under consideration. Thus, the solution to the given game is:

Optimal Strategy of A:  $21/52, 12/52, 19/52$ ;

Optimal Strategy of B:  $2/13, 3/13, 8/13$ ;

and Game Value,  $V = 2/13$ .

**Illustration 6**

Two companies A and B are competing for the same product. Their strategies are given in the following payoff matrix :

Use linear programming to determine the best strategies for both players.

		Company B		
Company A	1	3	-4	2
	2	1	-3	-7
	3	-2	4	7

**Solution:**

**Step 1.** The given game does not possess a saddle point. So the value of game lies between - 2 and +3, it is possible that the value of game may be negative or zero. Thus a constant k is added to all the elements of pay-off matrix, which is at least equal to the negative of the maximum value i.e.,  $k \geq 2$ . Let  $k = 3$ , then the given payoff matrix becomes :



$$\begin{matrix} & \text{Company B} \\ \text{Company A} & \begin{bmatrix} 6 & -1 & 5 \\ 4 & 0 & -4 \\ 1 & 7 & 10 \end{bmatrix} \end{matrix}$$

Let the strategies of Company A be designated by  $p_1, p_2$  and  $p_3$  and that of Company B by  $q_1, q_2$  and  $q_3$  respectively, such that

$$p_1 + p_2 + p_3 = 1 \text{ and } q_1 + q_2 + q_3 = 1$$

If the value of the game is  $v$ , then for company A, we must have

$$6p_1 + 4p_2 + p_3 \geq v, -p_1 + 7p_3 \geq v, 5p_1 - 4p_2 + 10p_3 \geq v$$

and for company B, we shall have

$$6q_1 - q_2 + 5q_3 \leq v, 4q_1 - 4q_3 \leq v, q_1 + 7q_2 + 10q_3 \leq v$$

$$\text{Let us define : } X = \frac{p_i}{V} \text{ (i = 1, 2, 3) and } y = \frac{q_i}{V} \text{ (i = 1, 2, 3)}$$

The problem for Company A, then is to determine  $x_1, x_2$  and  $x_3$  so as to

$$\text{Minimize } x_1 + x_2 + x_3$$

Subject to the constraints

$$6x_1 + 4x_2 + x_3 \geq 1, -x_1 + 7x_3 \geq 1; 5x_1 - 4x_2 + 10x_3 \geq 1; x_1, x_2, x_3 \geq 0$$

For company B, the problem is of determining  $y_1, y_2$  and  $y_3$  so as to

$$\text{Maximize } y_1 + y_2 + y_3$$

Subject to the constraints

$$6y_1 - y_2 + 5y_3 \leq 1; 4y_1 - 4y_2 \leq 1; y_1 + 7y_2 + 10y_3 \leq 1; y_1, y_2, y_3 \geq 0$$

The company B's problem is now solved by simplex method. Introducing the slack variables  $s_1 \geq 0, s_2 \geq 0$  and  $s_3 \geq 0$  in the constraints of the problem and then making use of the simplex method, the following simplex tables are obtained.

$C_j$ $C_B$	Basic Variables	Solution Values	1 $y_1$	1 $y_2$	1 $y_3$	0 $s_1$	0 $s_2$	0 $s_3$	Min Ratio
0	$s_1$	1	6*	-1	5	1	0	0	1/6 →
0	$s_2$	1	4	0	-4	0	1	0	1/4
0	$s_3$	1	1	7	10	0	0	1	1
	$Z_j$		0	0	0	0	0	0	
	$C_j - Z_j$		1↑	1	1	0	0	0	
1	$y_1$	1/6	1	-1/6	5/6	1/6	0	0	-1
0	$s_2$	-5/12	0	2/3	-22/3	-2/3	1	0	-ve
0	$s_3$	5/6	0	43/6*	55/6	-1/6	0	1	5/43 →
	$Z_j$		1	-1/6	5/6	1/6	0	0	
	$C_j - Z_j$		0	7/6	1/6↑	-1/6	0	0	
1	$y_2$	8/43	1	0	45/43	7/43	0	1/43	
0	$s_2$	85/172	0	0	-352/43	-28/43	1	-4/32	
1	$y_1$	5/43	0	1	55/43	-1/43	0	6/43	
	$Z_j$		1	1	100/43	6/43	0	7/43	
	$C_j - Z_j$		0	0	-57/43	-6/43	0	-7/43	

Since all the numbers in the Index (i.e.,  $C_j - Z_j$ ) row are either zero or negative, the optimal solution is being attained and is given by :

$$y_1 = \frac{8}{43}, y_2 = \frac{5}{43}, y_3 = 0, \text{ and } \frac{1}{v} = y_1 + y_2 + y_3 = \frac{8}{43} + 0 + \frac{5}{43} = \frac{13}{43}$$

$\therefore$  Value of the game for the modified matrix,  $v = \frac{43}{13}$

$$\text{Now } q_1 = y_1, v = \frac{8}{43} \times \frac{43}{13} = \frac{8}{13}, q_2 = y_2 \cdot v = \frac{5}{43} \times \frac{43}{13} = \frac{5}{13} \text{ and } q_3 = y_3 = 0$$

Company A's best strategies appear in the  $C_j - Z_j$  row under  $s_1, s_2$  and  $s_3$  respectively with negative signs.

$$\therefore X_1 = \frac{6}{43}, \quad x_2 = 0 \quad \text{and} \quad x_3 = \frac{7}{43}$$

Thus

$$p_1 = x_1, v = \frac{6}{43} \times \frac{43}{13} = \frac{6}{13}, p_2 = x_2, v = 0, \text{ and } p_3 = x_3, v = \frac{7}{43} \times \frac{43}{13} = \frac{7}{13}$$

Hence optimal strategies for company A are:  $\left[ \frac{6}{13}, 0, \frac{7}{13} \right]$ , for company B are  $\left[ \frac{8}{13}, \frac{5}{13}, 0 \right]$  and the value of game is :  $\frac{43}{13} - 3 = \frac{4}{13}$ .

#### 4.1.8 Extensive Form Games

The models we have described so far can capture a wide range of strategic environments, but they have an important limitation. In each game we have looked at, each player moves once and strategies are chosen simultaneously. This misses a common feature of many economic settings (and many classic "games" such as chess or poker). Consider just a few examples of economic environments where the timing of strategic decisions is important:

- Compensation and Incentives. Firms first sign workers to a contract, then workers decide how to behave, and frequently firms later decide what bonuses to pay and/or which employees to promote.
- Research and Development. Firms make choices about what technologies to invest in given the set of available technologies and their forecasts about the future market.
- Monetary Policy. A central bank makes decisions about the money supply in response to inflation and growth, which are themselves determined by individuals acting in response to monetary policy, and so on.
- Entry into Markets. Prior to competing in a product market, firms must make decisions about whether to enter markets and what products to introduce. These decisions may strongly influence later competition.

#### The Extensive Form

The extensive form of a game is a complete description of:

1. The set of players
2. Who moves when and what their choices are
3. What players know when they move
4. The players' payoffs as a function of the choices that are made.

## Examples

We start with a few examples.

**An Entry Model** Firm 1 is an incumbent monopolist. A second firm, Firm 2, has the opportunity to enter. After Firm 2 enters, Firm 1 will have to choose how to compete: either aggressively (Fight), or by ceding some market share (Accommodate). The strategic situation can be represented as follows.

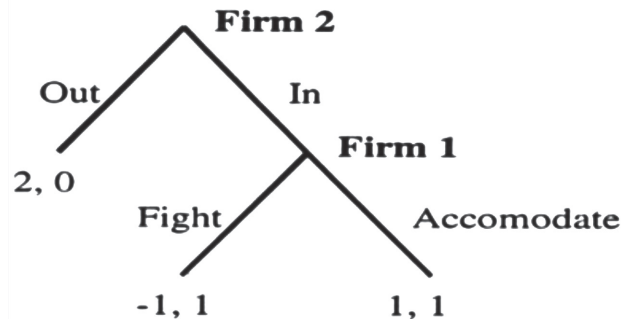

**Stackleberg Competition** An alternative to the Bertrand or Cournot models of imperfect competition is to assume that one firm is the market leader, while the other firm (or firms) are followers. In the Stackleberg model, we think of Firm 1 as moving first, and setting a quantity  $q_1$ , and Firm 2 as moving second, and setting a quantity  $q_2$ , after having observed  $q_1$ . The price is then determined by

$P(q_1 + q_2) = 1 - (q_1 + q_2)$ . Let's assume that the two firms have constant marginal costs,  $C = 0$ . To keep the picture simple, we think of  $q_i$  as taking only two values, Low and High.

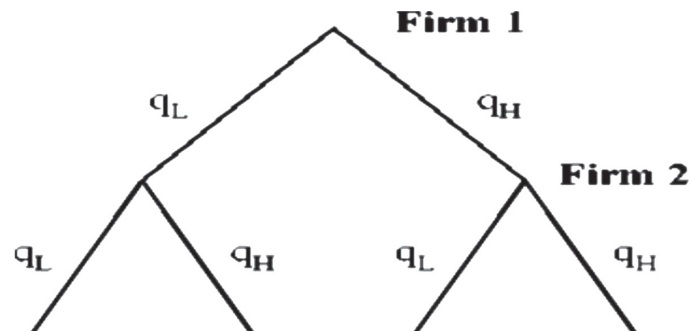

**Matching Pennies** Or consider two variants of the matching pennies game. In the first variant, player one moves first, and then player two moves second after having observed player one's action. In the second, player two does not observe player one's action.

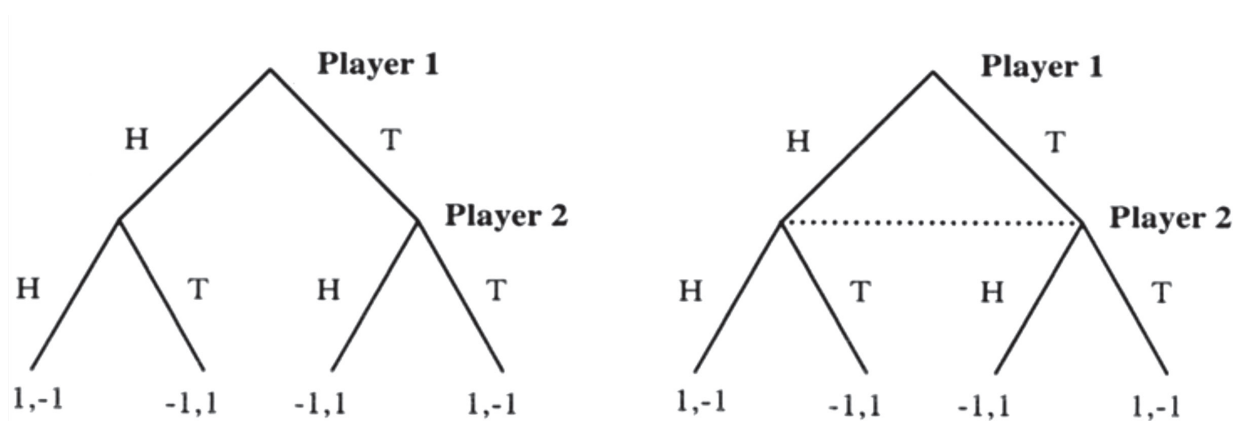

**Example** We can also have more complicated games, where players move multiple times, or select which player will move.

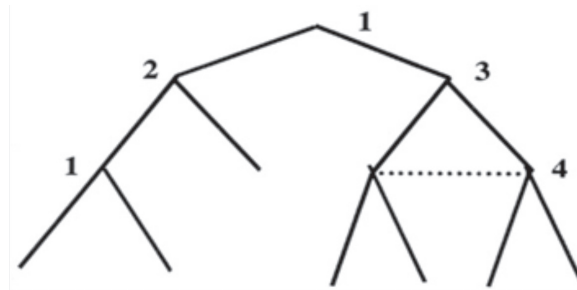

**Formal Definitions**

Formally, a finite extensive form game consists of:

- A finite set of players  $i = 1, \dots, I$ .
- A finite set  $X$  of nodes that form a tree, with  $Z \subset X$  being the terminal nodes.
- A set of functions that describe for each  $x \notin Z$ ,
  - The player  $i(x)$  who moves at  $x$ .
  - The set  $A(x)$  of possible actions at  $x$ .
  - The successor node  $n(x, a)$  resulting from action  $a$ .
- Payoff functions  $u_i : Z \rightarrow \mathbb{R}$  assigning payoffs to players as a function of the terminal node reached.
- An information partition: for each  $x$ , let  $h(x)$  denote the set of nodes that are possible given what player  $i(x)$  knows. Thus, if  $x' \in h(x)$ , then  $i(x') = i(x)$ ,  $A(x') = A(x)$  and  $h(x') = h(x)$ .

We will sometimes use the notation  $i(h)$  or  $A(h)$  to denote the player who moves at information set  $h$  and his set of possible actions.

**Matching Pennies, cont.** Let's revisit the two versions of matching pennies above. In both, we have seven nodes, three of which are non-terminal. The key difference is the information partition. In the first version, each  $h(x) = \{x\}$  for each  $x$ . In the second, for the two middle nodes we have  $h(x) = h(x') = \{x, x'\}$ .

In an extensive form game, write  $H_i$  for the set of information sets at which player  $i$  moves.

$$H_i = \{S \subset X : S = h(x) \text{ for some } x \in X \text{ with } i(x) = i\}$$

Write  $A_i$  for the set of actions available to  $i$  at any of his information sets.

**Strategies**

**Definition 1** A pure strategy for player  $i$  in an extensive form game is a function  $S_i : H_i \rightarrow A_i$  such that  $S_i(h) \in A(h)$  for each  $h \in H_i$ .

A strategy is a complete contingent plan explaining what a player will do in every situation. Let  $S_i$  denote the set of pure strategies available to player  $i$ , and  $S = S_1 \times \dots \times S_I$  denote the set of pure strategy profiles. As before, we will let  $s = (s_1, \dots, s_I)$  denote a strategy profile, and  $s_{-i}$  the strategies of  $i$ 's opponents.

**Matching Pennies, cont.** In the first version of matching pennies,  $S_1 = \{H, T\}$  and  $S_2 = \{HH, HT, TH, TT\}$ . In the second version,  $S_1 = S_2 = \{H, T\}$ .

There are two ways to represent mixed strategies in extensive form games.

**Definition 2** A mixed strategy for player  $i$  in an extensive form game is a probability distribution over pure strategies, i.e. some  $\sigma_i \in \Delta(S_i)$ .



**Definition 3** A behavioral strategy for player  $i$  in an extensive form game is a function  $\sigma_i : H_i \rightarrow \Delta(A_i)$  such that  $\text{support}(\sigma_i(h)) \subset A_i(h)$  for all  $h \in H_i$ .

A famous theorem in game theory, Kuhn's Theorem, says that in games of perfect recall (these are games where (i) a player never forgets a decision he or she took in the past, and (ii) never forgets information she had when making a past decision), mixed and behavioral strategies are equivalent, in the sense that for any mixed strategy there is an equivalent behavioral strategy and vice versa. Since essentially all the games we will consider have perfect recall, we will use mixed and behavioral strategies interchangeably.

### The Normal Form and Nash Equilibrium

Any extensive form game can also be represented in the normal form. If we adopt a normal form representation, we can solve for the Nash equilibrium.

**Matching Pennies, cont.** For our two versions of Matching Pennies, the normal forms are:

	HH	HT	TH	TT
H	1, -1	1, -1	-1, 1	-1, 1
T	-1, 1	1, -1	-1, 1	1, -1

	H	T
H	1, -1	-1, 1
T	-1, 1	1, -1

In the first version, Player two has a winning strategy in the sense that she can always create a mismatch if she adopts the strategy TH. Any strategy for player one, coupled with this strategy for player two is a Nash equilibrium. In the second version, the Nash equilibrium is for both players to mix  $\frac{1}{2} H + \frac{1}{2} T$

**Entry Game, continuation** For the entry game above, the normal form is:

	Out	In
F	2, 0	-1, 1
A	2, 0	1, 1

There are several Nash equilibria: (A, In), (F, Out) and  $(\alpha F + (1 - \alpha) A, Out)$  for any  $\alpha \geq 1/2$ .

Note that in the entry game, some of the Nash equilibria seem distinctly less intuitive than others. For instance, in the (F, Out) equilibrium, it is the threat of Fight that keeps Firm 2 from entering. However, if Firm 2 were to enter, is it reasonable to think that Firm 1 will actually fight? At this point, it is not in Firm 1's interest to fight, since it does better by accommodating.

Consider another example, where this problem of incredible threats arises in way that is potentially even more objectionable.

**Stackleberg Competition** In the Stackleberg model, for any  $q'_1 \in [0, 1]$ , there is a Nash equilibrium in which Firm 1 chooses quantity  $q'_1$ . To see this, consider the strategies:

$$s_1 = q'_1$$

$$s_2 = \begin{cases} \frac{1 - q'_1}{2} & \text{if } q_1 = q'_1 \\ 1 - q' & \text{if } q_1 \neq q'_1 \end{cases}$$

Let's check that these are all equilibria. First, given Firm 2's strategy, Firm 1 can either set  $q_1 \neq q'_1$  or  $q_1 = q'_1$ . If it does the former, the eventual price will be zero, and Firm 1 will make zero profits. If it does the latter, then Firm 1 will make profits:

$$q'_1 \left( 1 - q'_1 - \frac{1 - q'_1}{2} \right) = \frac{1}{2} q'_1 (1 - q'_1) \geq 0$$

Now, consider Firm 2. Does it have a strategy that yields strictly higher payoff. Clearly, changing its strategy in response to  $S_1 \neq q'_1$  will have no effect on its payoff given Firm 1's strategy. On the other hand, in response to  $S_1 = q'_1$  its best response solves:

$$\max_{q_2} q_2(1 - q'_1 - q_2)$$

The solution to this problem is  $(1 - q'_1) / 2$ , so Firm 2 is playing a best response.

As in the previous case, many of the Nash equilibria in the Stackelberg model seem unreasonable. If Firm 1 sets  $q_1 \neq q'_1$ , then Firm 2 typically has options that give a positive payoff. However, it chooses to flood the market and drive the price to zero. Thus, off the equilibrium path, unreasonable things are happening. And not only is Firm 2 being allowed to make incredible threats, we have a huge multiplicity of equilibria.

### Subgame Perfect Equilibrium

In response to the problems of credibility we have seen in the last two examples, we now introduce the idea of a subgame perfect equilibrium. Subgame perfection tries to rule out incredible threats by assuming that once something has happened, players will always optimize going forward.

### Subgame Perfection

**Definition 4** Let  $G$  be an extensive form game, a subgame  $G'$  of  $G$  consists of (i) a subset  $Y$  of the nodes  $X$  consisting of a single non-terminal node  $x$  and all of its successors, which has the property that if  $y \in Y, y' \in h(y)$  then  $y' \in Y$ , and (ii) information sets, feasible moves, and payoffs at terminal nodes as in  $G$ .

**Entry Game, cont.** In the entry game, there are two subgames. The entire game (which is always a subgame) and the subgame after Firm 2 has entered the market.

**Example** In game below, there are four subgames: (1) The entire game, (2) the game after player one chooses R, (3) the game after player one chooses L, and (4) the game after Player 1 chooses L and player 2 chooses.

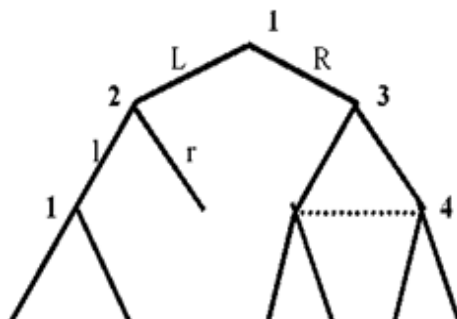

**Definition 5** A strategy profile  $s$  is a **subgame perfect equilibrium** of  $G$  if it induces a Nash equilibrium in every subgame of  $G$ .

Note that since the entire game is always a subgame, any SPE must also be a NE.

Entry Game, cont. In the entry game, only (A, In) is subgame perfect.

### Application: Stackleberg Competition

Consider the model of Stackleberg Competition where Firm 1 moves first and chooses quantity  $q_1$ , and then Firm 2 moves second and chooses quantity  $q_2$ . Once both firms have chosen quantities, the price is determined by:  $P(Q) = 1 - Q$ , where  $Q = q_1 + q_2$ . So that we can compare this model to Bertrand and Cournot competition, let's assume that both firms have constant marginal cost equal to  $0 \leq c < 1$ .

To solve for the subgame perfect equilibrium, we work backward. Suppose that Firm 1 has set some quantity  $q_1$ . Then Firm 2's best response solves:

$$\max_{q_2} q_2 (1 - q_1 - q_2 - c)$$

The first-order condition for this problem is:

$$0 = 1 - q_1 - c - 2q_2,$$

which gives a best response:

$$q_2^*(q_1) = \max \left\{ 0, \frac{1 - q_1 - c}{2} \right\}$$

Now consider the problem of Firm 1, knowing that if it chooses  $q_1$ , Firm 2 will respond with a quantity  $q_2^*(q_1)$ . It solves

$$\max_{q_1} q_1 (1 - q_1 - q_2^*(q_1) - c)$$

The first-order condition for this problem is:

$$0 = 1 - q_2 - c - 2q_1 - q_1 \frac{dq_2^*}{dq_1}$$

Solving this out yields:

$$q_1 = \frac{1 - c}{2} \text{ and } q_2 = \frac{1 - c}{4}.$$

The total quantity is  $3/4 (1 - c)$  and the price is  $p^s = (1 + 3c)/4$ . In comparison, under Cournot competition,

both firms set identical quantity  $\frac{1 - c}{3}$ , so total quantity is  $\frac{2}{3} (1 - c)$  and the price is  $p^c = (1 + 2c) / 3$ .

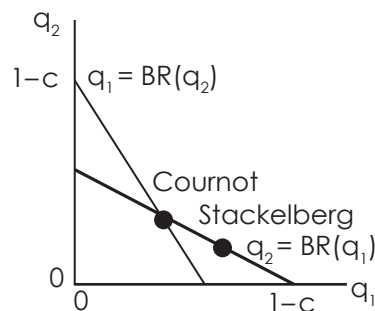

Stackelberg Competition

Relative to Cournot, in Stackelberg Competition, the Leader (Firm 1) can choose any point on the Follower's (Firm 2's) best-response curve. Note that this game has a first-mover advantage in the sense that there is an advantage to being the leader.

### Backward Induction

As the previous examples illustrate, a common technique for identifying subgame perfect equilibria is to start at the end of the game and work back to the front. This process is called backward induction.

**Definition 6** An extensive form game is said to have **perfect information** if each information set contains a single node.



**Proposition 7** (Zermelo's Theorem) Any finite game of perfect information has a pure strategy subgame perfect equilibrium. For generic payoffs, there is a unique SPE.

**Proof.** (very informal) In a finite game of perfect information, we can label each node as belonging to stage 1, stage 2, ..., stage K. To find a pure strategy SPE (and for generic payoffs, the unique SPE), we first consider all nodes x in stage K. Each node starts a subgame, so by NE the player who moves must maximize his or her expected payoff. Identify the optimal choice (generically, it will be unique). Now move back to stage K - 1, and consider the problem facing a player who moves here. This player can assume that at stage K, play will follow the choices just identified. Since each node starts a subgame, we look for the payoff-maximizing choice facing a player who gets to move. Once these choices have been identified, we move back to stage K - 2. This process continues until we reach the beginning of the game, at which point we will have at least one (and typically no more than one). Q.E.D.

**Example** Here is a non-generic game where backward induction reveals three pure strategy subgame perfect equilibria: (R, A), (R, B) and (L, B).

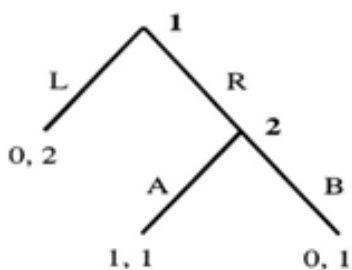

We can use backward induction even in games without perfect information as the next example demonstrates.

**Example** To use backward induction in the game below, we first solve for the subgame perfect equilibrium after Firm 2 has entered. We see that the unique equilibrium in this subgame is for both Firm 1 and Firm 2 to play D. (Note that this subgame is a prisoners' dilemma. Hence Firm 2 will choose not to enter at the first node.)

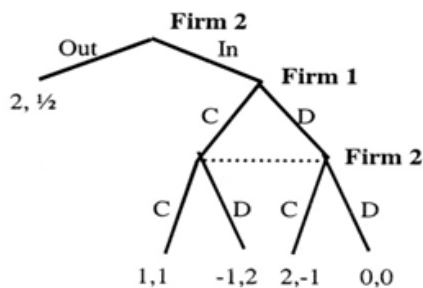

**Another Entry Game**

**Criticisms of Subgame Perfection**

We motivated Subgame Perfection as an attempt to eliminate equilibria that involved incredible threats. As we go on to consider applications, we will use SPE regularly as a solution concept. Before we do this, however, it is worth pausing momentarily to ask whether SPE might be over-zealous in eliminating equilibria.

**Example: Trusting Someone to be Rational** Here the unique SPE is for Player 1 to choose R and Player 2 to choose B. However, Goeree and Holt (2001) report an experiment in which more than 50% of player ones play S.

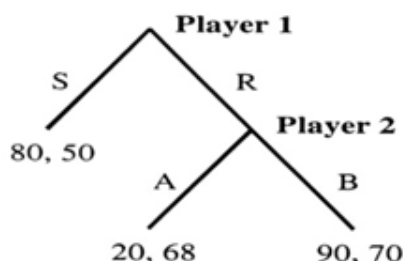

**The Centipede Game** In games with many stages, backward induction greatly stresses the assumption of rationality (and common knowledge of rationality). A famous example due to Rosenthal (1981) is the centipede game. The unique SPE is for Player 1 to start by moving Out, but in practice people do not seem to play the game this way.

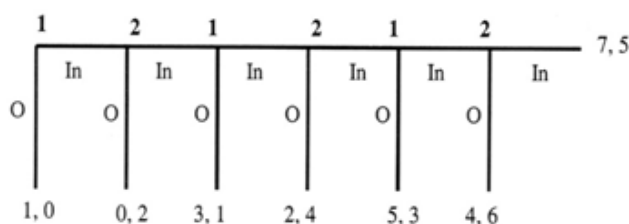

### Stackelberg (Leader-Follower) Games

Above, we considered Stackelberg competition in quantities. We now consider Stackelberg competition in prices, then fit both models into a more general framework.

#### Stackelberg Price Competition

In the Stackelberg version of price competition, Firm 1 moves first and commits to a price  $p_1$ . Firm 2 observes  $p_1$  and responds with a price  $p_2$ . Sales for Firm  $i$  are then given by  $Q_i(p_1, p_2)$ . Supposing that the two firms have constant marginal costs equal to  $c$ , firm  $i$ 's profits can be written as:

$$\pi_i(p_1, p_2) = (p_i - c)Q_i(p_1, p_2).$$

**Homogeneous Products.** If the firms' products are heterogeneous, then the firm that sets a lower price gets demand  $Q(p)$  (where  $p = \min\{p_1, p_2\}$ ), and the firm that sets a higher price gets no demand. Suppose that if  $p_1 = p_2$  the consumers split equally between the two firms. In this case, if Firm 1 chooses  $p_1 > c$ , Firm 2 would like to choose the highest price less than  $p_1$ . Unfortunately, such a price does not exist! So there are subgames in which Nash equilibria do not exist and no SPE.

To resolve this, assume that if  $p_1 = p_2$ , then all consumers purchase from Firm 2. Then after observing  $p_1 \geq c$ , Firm 2 responds by taking the entire market – either by choosing  $p_2 = p_1$  if  $p_1 \leq p^m$  (the monopoly price), or by choosing  $p_2 = p^m$  if  $p_1 > p^m$ . It follows that Firm 2's best response function is given by:

$$p_2^*(p_1) = \begin{cases} p^m & \text{if } p_1 > p^m \\ p_1 & \text{if } p_1 \in [c, p^m] \\ c & \text{if } p_1 < c \end{cases}$$

Thus, for any  $p < c$ , Firm 1 gets the entire market but loses money, which for any  $p_1 \geq c$ , Firm 1 gets no demand. It follows that any pair  $(p_1, p_2^*(p_1))$  with  $p_1 \geq c$  is an SPE.

Note that compared to the Bertrand (simultaneous move) equilibrium, the price may be higher. In

particular, both Firms 1 and 2 set (weakly) higher prices. Moreover, Firm 2 (the follower) does better than in the simultaneous game, while Firm 1 does the same. Thus we say the game has a second mover advantage.

**Heterogeneous Products.** With heterogeneous products, the situation is similar to Stackelberg quantity competition, except with Bertrand best-responses rather than Cournot!

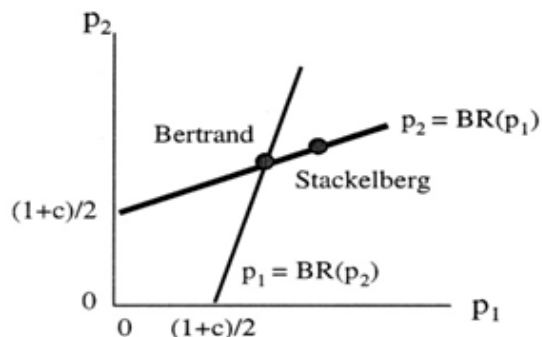

**General Leader-Follower Games**

The Stackelberg models of imperfect competition are examples of what Gibbons calls “Leader-Follower” games. These games have the following structure:

1. Player 1 moves first and chooses an action  $a_1 \in A_1$ .
2. Player 2 observes  $a_1$  and chooses an action  $a_2 \in A_2$ .

There is a simple algorithm to identify the subgame perfect equilibria of this sort of game. We just apply backwards induction. We first define player 2’s best response to any action by Player 1:

$$a_2^*(a_1) = \arg \max_{a_2 \in A_2} \pi_2(a_1, a_2).$$

We then identify what player one should do, assuming that player two will best respond. To do this, define:

$$a_1^* = \arg \max_{a_1 \in A_1} \pi_2(a_1, a_2^*(a_1)).$$

A subgame perfect equilibrium is a pair  $(a_1^*, a_2^*(a_1^*))$ .

From our examples, we can make several observations about leader-follower games.

1. The Leader always does (weakly) better than in a simultaneous move pure strategy equilibrium setting (note that this is not true for mixed strategy equilibria – think about matching pennies).
2. The Leader tends to distort his behavior relative to the simultaneous move game (how he does so depends on Firm 2’s best response function and on what sort of action he prefers Firm 2 to choose).
3. Whether the Follower does better than in the simultaneous game depends on both Firm 2’s best response function and the interdependence in payoffs (how  $i$ ’s action affects  $j$ ’s payoff and vice-versa).

**Strategic Pre-Commitment**

We now turn to a class of problems that arise frequently in industrial organization. These problems have the following structure. First, one player (Firm 1) has the opportunity to take some sort of action or investment – for instance, installing capacity, investing in a cost-saving technology or in product

development, signing an exclusive contract with a key upstream suppliers, building a relationship with customers, or so on. Then Firm 2 decides whether or not to enter the market. Finally, firms compete with Firm 1 either operating as a monopoly or the two firms competing as a duopoly.

By taking an action in advance of competition, Firm 1 has the opportunity to *strategically* pre-commit (just as the Stackelberg leader pre-commits to a price or quantity). It turns out that it is possible to give a very intuitive analysis of the economics of pre-commitment by using the idea of strategic complements and substitutes. This analysis can then be used to shed light on a range of problems in industrial organization and other fields.

### Strategic Complements and Substitutes

Let  $G$  be a simultaneous move game in which the players 1 and 2 takes actions  $a_1, a_2 \in \mathbb{R}$ , and have payoffs  $\pi_1(a_1, a_2)$ ,  $\pi_2(a_1, a_2)$ . Let  $BR_1(a_2)$  and  $BR_2(a_1)$  denote the best-response functions (assume best responses are unique).

**Definition 8** The players' actions are **strategic complements** if  $BR'_i(\cdot) \geq 0$ . The actions are **strategic substitutes** if  $BR'_i(\cdot) \leq 0$ .

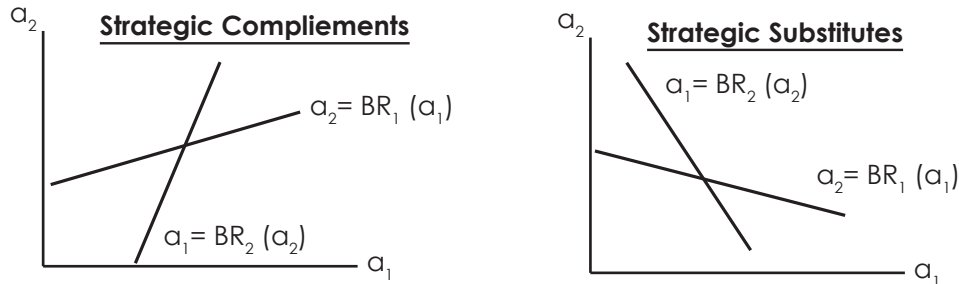

We have already seen that in Cournot Competition, quantities are strategic substitutes, while in differentiated products Bertrand Competition, prices are strategic complements.

**Proposition 9** Suppose for  $i = 1, 2, \dots$ ,  $\pi_i$  is twice continuously differentiable.

Then  $G$  has strategic complements if  $\frac{\partial^2 \pi_i}{\partial a_i \partial a_j} \geq 0$  and strategic substituted if  $\frac{\partial^2 \pi_i}{\partial a_i \partial a_j} \leq 0$ .

### Strategic Pre-Commitment

We consider the following model:

- Firm 1 moves first and chooses an investment  $k$ .
- Firm 2 observes  $k$  and decides whether or not to compete (enter).
- Firms 1 and 2 choose actions  $a_1 \in A_1$ ,  $a_2 \in A_2$ .
- Payoffs are given by  $\pi_1(k, a_1, a_2)$  and  $\pi_2(k, a_1, a_2)$ .<sup>2</sup>

We assume that for any choice  $k$ , the competition subgame has a unique Nash Equilibrium, which we can denote  $a_1^c(k)$ ,  $a_2^c(k)$ . Payoffs in this game are given by:

$$\pi_i(k, a_1^c(k), a_2^c(k)) \text{ for } i = 1, 2.$$

Thus given a choice of  $k$ , Firm 2 will choose to enter if

$$\pi_2(k, a_1^c(k), a_2^c(k)) > 0.$$

If Firm 2 does not enter, then Firm 1 sets chooses the monopoly strategy  $a_1^m$ . Payoffs are

$$\pi_1^m(k, a_1^m(k))$$

for Firm 1 and zero for Firm 2. Let  $k^*$  denote the subgame perfect level of investment.

We say that:

- Entry is deterred if  $\pi_2(k^*, a_1^c(k^*), a_2^c(k^*)) \leq 0$ .
- Entry is accommodated if  $\pi_2(k^*, a_1^c(k^*), a_2^c(k^*)) > 0$ .

If entry is deterred, then the SPE involves Firm 1 choosing  $a_1^m(k^*)$ , and achieves profits  $\pi_1^m(k^*, a_1^m(k^*))$ . If entry is accommodated, Firms choose  $a_1^c(k^*), a_2^c(k^*)$ .

An alternative to this model would be a case without pre-commitment where Firm 1 chooses  $k$  at the same time as  $a_1, a_2$  (or chooses  $k$  in advance but without it being observed). Let's assume that this game also has a unique Nash Equilibrium, denoted  $(k^{nc}, a_1^{nc}, a_2^{nc})$ . We will say that:

- Entry is *blockaded* if  $\pi_2(k^{nc}, a_1^{nc}, a_2^{nc}) \leq 0$ .

In what follows, we assume that entry is not blockaded. In addition, we will assume that  $\pi_1^m$  and  $\pi_1$  are both concave in  $k$ .

### Entry Deterrence

Let's first consider SPE in which entry is deterred. In this case, Firm 1 need to choose a level of  $k$  that makes Firm 2 less profitable. Indeed, it will choose an investment  $k^*$  such that:

$$\pi_2(k^*, a_1^c(k^*), a_2^c(k^*)) = 0$$

Let's consider what sort of strategy by Firm 1 works to make Firm 2 unprofitable and hence deter entry. From second period optimization:

$$\frac{\partial \pi_2}{\partial a_2}(k^*, a_1^c(k^*), a_2^c(k^*)) = 0$$

Hence:

$$\frac{d\pi_2}{dk} = \underbrace{\frac{\partial \pi_2}{\partial k}}_{\text{direct effect}} + \underbrace{\frac{\partial \pi_2}{\partial a_1} - \frac{\partial a_1}{\partial k}}_{\text{strategic effect}}$$

To deter entry, Firm 1 wants to choose an investment that will make Firm 2 less profitable. It has two ways to do this. It may be able to invest in a way that makes Firm 2 directly less profitable. It make also be able to change the nature of competition – for example, if  $k$  is investment in capacity,  $k$  has no direct effect, but only a strategic effect.

To classify Firm 1's strategies, we adopt the terminology of Fudenberg and Tirole (1984).

**Definition 10** Investment makes Firm 1 **tough** if  $\frac{dr_2}{dk} < 0$ . Investment makes Firm 1 **soft** if  $\frac{dr_2}{dk} > 0$ .

Fudenberg and Tirole suggest the following typology of strategies for investment.

- Top Dog: Be big (invest a lot) to look tough.
- Puppy Dog: Be small (invest only a little) to look soft.
- Lean and Hungry Look: Be small to look tough.
- Fat Cat: Be big to look soft.

**Example: Reducing Own Costs** Suppose that Firm 1 has the opportunity to invest to lower its marginal costs. If Firm 2 enters, competition will be Cournot. There is no direct effect on Firm 2. But there is a strategic effect. Investment will shift out Firm 1's best-response function, and lead to a competitive outcome where Firm 1 produces higher quantity and Firm 2 lower quantity. This *top dog* strategy may deter entry.

**Example: Building a Customer Base** Suppose that Firm 1 has the opportunity to invest in customer relations, building up a loyal customer base. The direct effect of this is to limit the potential market for

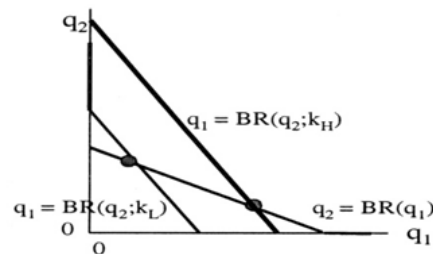

Firm 2, making Firm 1 tough. However, there may be a second effect. If Firm 1 cannot price discriminate, it may be tempted to set a high price to take advantage of its locked in customers. This strategic effect can work to make Firm 1 soft. The overall effect is ambiguous. Thus either a "top dog" strategy or a "lean and hungry look" might work to deter entry depending on the specifics.

### Accommodation: Changing the Nature of Competition

Suppose now that Firm 1 finds it too costly to deter entry. How should it behave in order to make more profits once Firm 2 enters? In this case, Firm 1 is interested in choosing its investment to maximize:

$$\pi_1(k, a^c_1(k), a^c_2(k)).$$

The total derivative is given by (using the envelope theorem):

$$\frac{d\pi_1}{dk} = \underbrace{\frac{\delta\pi_1}{\delta k}}_{\text{Direct effect}} + \underbrace{\frac{\delta\pi_1}{\delta a_2} \frac{da_2}{dk}}_{\text{Strategic effect}}$$

That is, the first term is the direct effect. This would exist even if investment was not observed by Firm 2. The strategic effect results from the fact that Firm 1's investment can change the way Firm 2 will compete.

Let's investigate the strategic effect further. To do this, let's assume that the second-period actions of the two firms have the same nature in the sense that  $\partial\lambda_1 / \lambda a_2$  has the same sign as  $\partial\lambda_2 / \lambda a_1$ . For instance, either both firms choose quantities or both choose prices. Then:

$$\frac{da_2^c}{dk} = \frac{da_2^c}{da_1} \frac{da_1}{dk} = \frac{dBR_2(a_1)}{da_1} \frac{da_1}{dk}$$

Thus,

$$\text{sign } \frac{d\pi_1}{dk} = \text{sign } \frac{d\pi_1}{da_2} \frac{da_2}{dk} = \text{sign } \frac{d\pi_1}{da_2} \frac{dBR_2(a_1)}{da_1} \frac{da_1}{dk}$$

Assuming that  $\partial\pi_2/\partial k = 0$ , we can identify the sign of the strategic effect with two things: (1) whether investment makes Firm 1 Tough or Soft (the first term) and (2) whether there are strategic substitutes or complements (the second term). We have four cases:

- If investment makes Firm 1 tough and reaction curve slope down, investment by Firm 1 softens Firm 2's action – thus Firm 1 should overinvest (top dog).
- If investment makes Firm 1 tough and reaction curves slope up, Firm 1 should overinvest so as not to trigger an aggressive response by Firm 2 (puppy dog).
- If investment makes Firm 1 soft and reaction curves slope down, Firm 1 should stay lean and hungry.
- If investment makes Firm 1 soft and reaction curves slope up, Firm 1 should overinvest to become a fat cat.

To summarize,

		Investment makes Firm 1	
		Tough	Soft
Strategic Complements		Puppy Dog	Fat Cat
	Strategic Substitutes	Top Dog	Lean and Hungry

**Example:** Reducing Costs - Suppose Firm 1 can invest to reduce its costs before competing. With Cournot competition, the strategic effect to make Firm 1 more aggressive. The equilibrium changes so that Firm 2 ends up producing less. Thus Firm 1 wants to be a Top Dog and invest heavily. On the other hand, if Firm 1 can reduce its costs before price competition, the strategic effect is to make Firm 1 more aggressive so that in equilibrium Firm 2 ends up pricing more aggressively as well. Thus, Firm 2 might want to be a Puppy Dog to soften price competition.

**Applications in Industrial Organization**

1. Product Differentiation. Suppose Firm 1 can choose its product's "location" prior to competing in price with Firm 2. Producing a product that is "close" to Firm 2's will tend to make price competition more intense, lowering prices and profits. To deter entry or to drive Firm 2 from the market, Firm 1 might want to adopt a "Top Dog" strategy. But to change the nature of competition in a favorable way, Firm 1 might want to adopt a "Puppy Dog" ploy and differentiate its offering from Firm 2's.
2. Most-Favored Customer Clause. With price competition, if Firm 1 wants to accommodate Firm 2, it wants to look inoffensive so as to keep Firm 2 from cutting price. In particular, it would like to commit itself to charging high prices (a "Puppy Dog" ploy). One way to do this is most-favored customer clauses. Firm 1 can write contracts with its customers promising that if it ever offers a low price to another customer, the original customer can get the new low price. This makes it very costly for Firm 1 to drop prices, effectively committing itself to be unaggressive in competing with Firm 2.
3. Advertising. Suppose Firm 1 can invest in advertising that makes customer more excited not just about its own product, but about the whole market. This kind of advertising makes Firm 1 soft. To deter entry, Firm 1 should not do much of this sort of advertising – rather it should run advertisements that increase the demand for its own product and decrease the demand for other firms' product. But what if Firm 2 surely plans to enter. If competition is in prices, then Firm 1 will want to advertise in a way that increases demand (direct effect) and in a way that softens price competition (for example by establishing separate niches for different products in the market). This is a fat cat approach to advertising.



4. Leverage and Tying. An old story in IO is that a firm with monopoly power in one market can leverage this power to monopolize a second. (Think Microsoft and browsers.) One way to do this is to tie the two products together. Suppose that there are two markets, that Firm 1 has a monopoly in the first, and that Firms 1 and 2 may compete in prices in the second. Firm 1 must decide whether to bundle or tie its two products. The question is how this action will effect its pricing behavior. This depends on how we model demand, but in many cases, bundling will make demand more elastic. This leads Firm 1 to price more aggressively in response to Firm 2's prices. It follows that from a strategic point of view, bundling is a top dog strategy that works to deter entry. But if entry is to be accomodated, it may be better to use the puppy dog ploy of not bundling.

## Case Study 1

### Why Toyota wants GM to be saved: a game theory case study

#### Here's the latest twist in the auto bailout:

Detroit's Big Three aren't the only automotive companies that want to see the government step in with some much needed financial help.

Overseas automakers, most notably Toyota Motor, all endorse some form of federal aid to keep General Motors, Chrysler LLC and possibly Ford Motor out of bankruptcy.

The news seems strange. The usual response is to kick a competitor while he is down. As McDonald's founder Ray Kroc put it. "If any of my competitors were drowning. I'd stick a hose in their mouth and turn on the water."

So why would Toyota help the Big Three? Game theory tells us to think deeper. The real reason Asian automakers want to help is out of self-interest. The CNN article explains several of the strategic reasons for helping the US automakers.

#### They involve:

- supply costs
- demand issues
- deterring new entrants

#### Supply costs:

While automakers are competitors in car sales, they are indirectly partners in the auto parts supplier market. The more cars that are sold-regardless of who sells them-the greater demand there is for parts, and consequently, the lower the price will be for everyone.

Asian companies have a vested interest in protecting demand for the delicate supply market.

The overseas automakers, who between them produce more than 3 million vehicles a year at U.S. plants, all worry their production would be hurt if one of the U.S. automakers went under. That's because a Big Three failure would likely lead to widespread bankruptcies in the auto parts supplier industry.

The risk is increased because many parts only have a single supplier. Ultimately costs and time for production would be increased in the transition period. And increased costs would further damage automakers because of demand issues.

#### Demand issues:

All automakers depend on another common item-the health of the U.S. economy. The more severe the recession, the worse car sales will be. Foreign automakers depend on U.S. sales and worry about further declines.



The pain has been tangible for Toyota which has had to cut production.

The latest cutbacks came Monday when Toyota announced it was putting plans to open a new plant in Mississippi on hold indefinitely, even though it is about 90% complete. The plant was set to start building the first domestically produced Prius in 2011.

Sometimes competition can be put aside for bigger issues. Asian companies are guessing that a Big Three bankruptcy would have too large an impact to ignore. That's why they are worried less about their share of the car market and more about how big the market will be.

**Deterring new entrants:**

High start-up costs often keep entrants out. They worry about joining a market where an incumbent can price gouge, drive them out, and then recover profits later. In the auto industry, there is also an issue of excess capacity-it might be unprofitable to join a market at current production levels.

And this is why Honda and Toyota are seared about the U.S. companies failing. It sets up a chance for entrants to come in much easier.

The final concern for the overseas automakers is a longer-term problem. If a U.S. automaker fails, that could open the door for a Chinese or Indian automaker to buy up the assets of the failed automaker and create a new low-cost competitor in the U.S.

While China and India may eventually come into the U.S. market, incumbents would rather have that happen later.

**In conclusion:**

Why it might not always be a good idea to kick your competitor when he is down — propping him up might be the lesser of two evils.

**Case Study 2**

**(1) Contractor Profile**

The construction company was found in 1997, specializing in general construction work. They had been completed over 50 contracts at all times in the south region. Their annual turnover volume exceeds RM 5,000,000. The company has been classified Grade 7 and Class A with CIDB and PKK respectively. The company current projects are housing development in Kempas, Kulai and Tampoi with the tender bid of RM 1 billion.

**Table 1. The table of measurement of business strategies in bid/no bid decision and bid price in competitive bidding (Contractor A)**

Business Strategies	Level of Measurement				
	5	4	3	2	1
	Critical	Strong	Average	Light	Poor
<b>Bid/No bid: Marketing</b>					
a. Market Prospect		/			
b. Market Range		/			
<b>Bid/No bid: Finance</b>					
a. Source of funds	/				
b. Project Profitability		/			



<b>Bid/No bid: Total of Measurement</b>	<b>20-17 Critical</b>	<b>16-13 Strong</b>	<b>12-9 Average</b>	<b>8-5 Light</b>	<b>4-1 Poor</b>
	17				
<b>Bid Price: Production/ Operation</b>					
a. Equipment/plant availability		/			
b. Equipment/plant size and capacity		/			
<b>Bid Price: Human Resource/Manpower</b>					
a. Organization	/				
b. Labor force		/			
<b>Bid Price: R&amp;D</b>					
a. Alternative construction method			/		
b. Productivity improvement	/				
<b>Bid Price: Total of Measurement</b>	<b>30-25 Critical</b>	<b>24-19 Strong</b>	<b>18-13 Average</b>	<b>12-7 Light</b>	<b>6-1 Poor</b>
	25				

### Business Strategies

**Marketing:** The company have been classified as big contractor because can bid for project above 10,000,000 in value. They able to declare their assumption to either existing or new client and agreed that many influenced client invite them for other project or other phase of the project. They tend to know the other competitors' strategies to cause competition in competitive bidding.

**Finance:** The Company has strong financial backup. The company gained a good reputation along the southern part of Johor and ventured with Singapore Company for some projects. The company interests in mix development. The development will attract the local residents to invest in such properties. According to them, the sole housing will be less attraction compared with mix development and commercial project. They tend to bid for the projects which are consisting of commercial area.

**Production:** The Company has strong equipment and plant. Empire Construction Sdn Bhd is a general work contractor and able to do the general structural work for every project.

**Manpower:** The company has a proper hierarchical organization as well. The General Manager, Contract Manager, Quantity Surveyor and Estimator will evaluate and estimate the tender bid. The company has sufficient labor force to subcontract as well.

**R&D:** The company would conduct alternative construction method if the original work can't process further. The company will inspect the entire subcontractor job before handing over. Productivity improvement is primary concern of the company.

### Game Tree/ Decision Tree

Figure. Overall business decision in bid/no bid and markup price decision in extensive form (Contractor C)

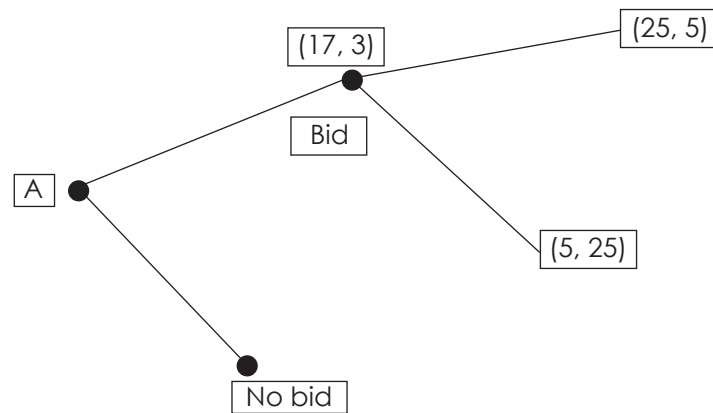

Responding to the decision model, contractor A will most probably determine to select bid decision. The possibility of chance for them to bid high, about 85% for every project. During determining of bid price, contractor A would bid the possible low price due to the payoff (25, 5) is the availability of company ability to bid a low price (See Figure). The variance of the payoff is about +20, it means greater low bid price will be accepted for the company.

**(2) Contractor Profile**

The company was established in 1992 and specializing in general construction work. The company has been classified as Grade 6 and Class B with CIDB board and PKK representatively. The company actives in the southern region with the annual turnover volume exceed RM 5,000,000 in private and government job. The current projects under construction are Senai Hospital, mix development in Kulai and housing development in Tampoi Indah, Johor.

**Table 2. The table of measurement of business strategies in bid/no bid decision and bid price in competitive bidding (Contractor B)**

Business Strategies	Level of Measurement				
	5 Critical	4 Strong	3 Average	2 Light	1 Poor
<b>Bid/No bid: Marketing</b>					
a. Market Prospect		/			
b. Market Range		/			
<b>Bid/No bid: Finance</b>					
a. Source of funds			/		
b. Project Profitability			/		
<b>Bid/No bid: Total of Measurement</b>	<b>20-17 Critical</b>	<b>16-13 Strong</b>	<b>12-9 Average</b>	<b>8-5 Light</b>	<b>4-1 Poor</b>
		<b>14</b>			
<b>Bid Price: Production/ Operation</b>					
a. Equipment/plant availability			/		
b. Equipment/plant size and capacity			/		
<b>Bid Price: Human Resource/Manpower</b>					
a. Organization		/			
b. Labor force				/	
<b>Bid Price: R&amp;D</b>					
a. Alternative construction method				/	
b. Productivity improvement					/
<b>Bid Price: Total of Measurement</b>	<b>30-25 Critical</b>	<b>24-19 Strong</b>	<b>18-13 Average</b>	<b>12-7 Light</b>	<b>6-1 Poor</b>
			<b>15</b>		

## Business Strategies

**Marketing:** The company have been classified as G6 as medium sized contractors that can bid for project no more than RM10, 000,000 in value. They agreed that business marketing prospect influence client for tender inviting. They will attempt to know who other competitors and their other consumption so that can create the competitive reasonable price to win the project.

**Finance:** The company is sufficient but not strong in financial. According to the Senior Engineer, his company's financial is capable of project cash flow currently. If the next project awarded, they might tender out again to get bid low to reduce the overall project cost. They would choose the government job rather than private because in the government job it is easy to get the period payment from client.

**Production:** The company has strong equipment and plant. Empire Construction Sdn Bhd is a general work contractor and able to do the general structural work for every project. The supply source of equipment/ material is strong due to the good interaction in industry relationship. The availability of equipment/plant is available strong in the company.

**Manpower:** The company has a proper organization which consists of different executives for private job and government job representatively. The labor force depends on the scale of the project. If the project needs more labor forces, they will try to instruct the subcontractor and supplier to allocate more labor force.

**R&D:** According to the company, they seldom conduct alternative construction method and productivity improvement activity at the site. They claimed that inspection work done by the main contractor and architect will do.

## Game Tree/Decision

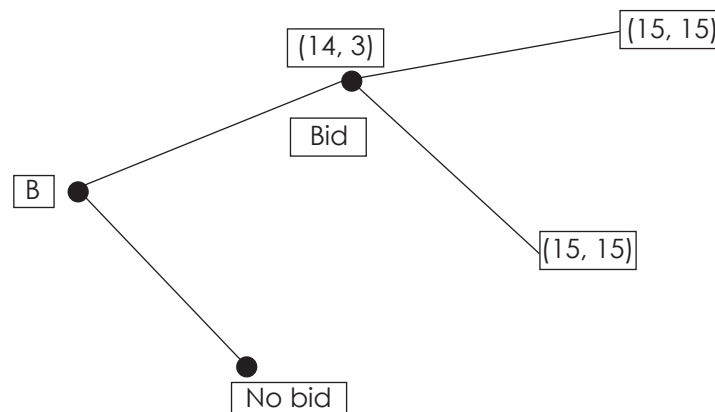

**Figure. Overall business decision in bid/no bid and markup price decision in extensive form (Contractor B)**

The decision tree evolved from the business strategies measurement to determine the bid/no bid price decision. Contractor B would select to bid for next tender based on the payoff shows (14, 6), possibility of chance for them to bid is high, about 70%. The variance of payoff responds +/-0. They would not bid the price low; they only can bid the average bid price and hope to get the project win (See Figure).

### (3) Contractor Profile

The company is an associated company with a listed company in KLSE main board. The company has been classified Grade 7 contractor and provides general construction work and project management. Their current project is likely biggest shopping mall in Penang.

**Table 5. The table of measurement of business strategies in bid/no bid decision and bid price in competitive bidding (Contractor C)**

Business Strategies	Level of Measurement				
	5 Critical	4 Strong	3 Average	2 Light	1 Poor
<b>Bid/No bid: Marketing</b>					
a. Market Prospect				/	
b. Market Range				/	
<b>Bid/No bid: Finance</b>					
a. Source of funds		/			
b. Project Profitability				/	
<b>Bid/No bid: Total of Measurement</b>	<b>20-17 Critical</b>	<b>16-13 Strong</b>	<b>12-9 Average</b>	<b>8-5 Light</b>	<b>4-1 Poor</b>
			<b>10</b>		
<b>Bid Price: Production/ Operation</b>					
a. Equipment/plant availability			/		
b. Equipment/plant size and capacity		/			
<b>Bid Price: Human Resource/Manpower</b>					
a. Organization	/				
b. Labor force		/			
<b>Bid Price: R&amp;D</b>					
a. Alternative construction method		/			
b. Productivity improvement		/			
<b>Bid Price: Total of Measurement</b>	<b>30-25 Critical</b>	<b>24-19 Strong</b>	<b>18-13 Average</b>	<b>12-7 Light</b>	<b>6-1 Poor</b>
		<b>24</b>			

**Business Strategies**

**Marketing:** The company is an associated company of listed company and registered as Grade 7 contractor with CIDB. The person in charge cum resident engineer claimed that the company is acted as in-house contractor to the mother company in Kuala Lumpur. The project will only process when the associate company approves the project and issues the construction work.

**Finance:** The company has a strong financial backup. They do no need to measure the project profitability because the company is only subsidiary company and the measurement of project profitability done by main and associate company.

**Production:** The company indicated strong condition in equipment and plant. According to resident engineer, the company primarily focuses the time and cost management of construction work. All the work to be sub divided to other contractors. The equipment / plant is available for the other project at the moment.

**Manpower:** The company is critically strong in organization. The decision and meeting need to transform into paperwork and to be reported to every level of organization. The team of the organization is mainly consists of professionals like Engineer, Quantity Surveyor and Financial experts.

**R&D:**As project management team, the contractor will inspire the alternative construction method and productivity improvement as long as within the cost budget and effective in timely manner.

**Game Tree / Decision Tree**

Figure. Overall business decision in bid/no bid and markup price decision in extensive form (Contractor C)

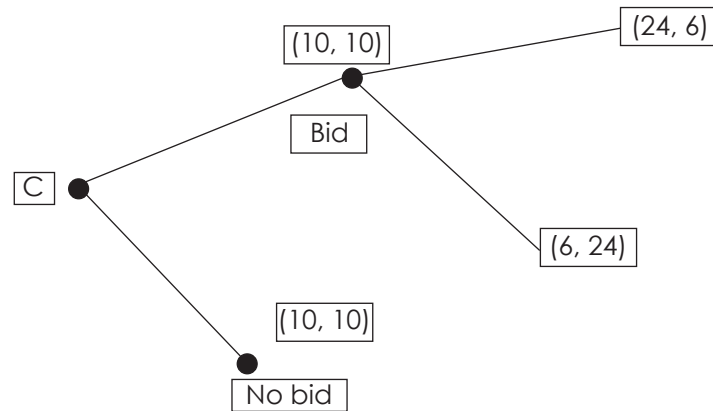

The possibility of chance for contractor C is only 50%. This is because the company is only subsidiary company and in-house contractor; top management takes all the decision from main company. Although, the company reports unbalance performance in production strategies, but the company shows great performance in research and development strategies. These allow the company to determine the bid price when they participate in competitive bidding (Figure). The variance reports greater low price, about +18.

#### (4) Contractor profile

The company commenced business in 2004 and classified as Grade 3 contractor. The company was established from conversion from manufacturer to contractor. The current project is their own factory with the cost volume less than RM 1,000,000. The company's key personnel is a Chinese family based organization

**Table 5. The table of measurement of business strategies in bid/no bid decision and bid price in competitive bidding (Contractor D)**

Business Strategies	Level of Measurement				
	5	4	3	2	1
	Critical	Strong	Average	Light	Poor
<b>Bid/No bid: Marketing</b>					
a. Market Prospect		/			
b. Market Range		/			
<b>Bid/No bid: Finance</b>					
a. Source of funds			/		
b. Project Profitability		/			
<b>Bid/No bid: Total of Measurement</b>	<b>20-17 Critical</b>	<b>16-13 Strong</b>	<b>12-9 Average</b>	<b>8-5 Light</b>	<b>4-1 Poor</b>
		15			
<b>Bid Price: Production/ Operation</b>					
a. Equipment/plant availability				/	
b. Equipment/plant size and capacity				/	
<b>Bid Price: Human Resource/Manpower</b>					
a. Organization				/	
b. Labor force				/	

<b>Bid Price: R&amp;D</b>					
a. Alternative construction method					/
b. Productivity improvement					/
<b>Bid Price: Total of Measurement</b>	<b>30-25 Critical</b>	<b>24-19 Strong</b>	<b>18-13 Average</b>	<b>12-7 Light</b>	<b>6-1 Poor</b>
				<b>10</b>	

**Business Strategies**

**Marketing:** The contractor is the new comer and fresh on the construction field. They will only focus on the factory or warehouse construction work in the market. Their marketing strategies are to emphasis on the design and built or turnkey procurement. They will coordinate their own design team and offer their spec into drawing. The quotation will be made based on the final drawing to the client.

**Finance:** The company has registered as Grade 3 contractor and has an average financial source. They have been persuaded that factory work could be advantage project profitability because the payment could be cleared easily.

**Production:** The Company shows poor in equipment/ plant and supply source because they subdivided the tender again. Therefore, they do not tend to have the relevant equipment on the site.

**Manpower:** The Company has flat organization which means the scale of organization is less complicated. A few general clerks on the organization are needed to run the daily operation.

**R&D:** The alternative construction method and productivity will be less encourage by the company due to the costly reason. Light improvement will be considered as long as effective in term of cost and time. The company did not find it easy making breakthrough.

**Game Tree/ Decision Tree**

**Figure. Overall business decision in bid/no bid and markup price decision in extensive form (Contractor D)**

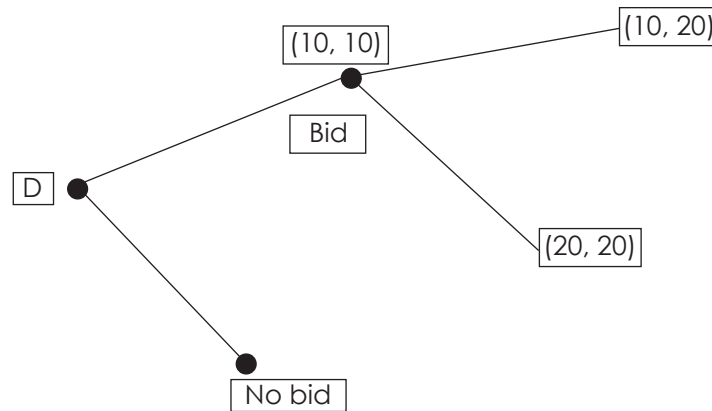

It would be possible of the company marketing strategies, the bid or no bid decision shows the surprising payoff; bid or no bid in 50% each. The company will only decide to bid at the pinch. Beside that, the payoff of markup price totally against with the conventional procurements' payoff. The contractor tends to bid the high price. The procurement system may be the main reason to influence the mark up price because the quotation is under a package work to the client.

There are several analyses can be carried out base on comparative studies above:

- The large scale firms which are grade 7 or class A contractors tend to select bid decision in greater probabilities (more than 80%) and willing to bid a greater low price (variance = + 20).
- The large scale firm which is in-house base contractor only decides the bid/no bid decision based on their top management. The relevant contractor would able to bid a greater bid price to compete other competitor as well.
- The medium size contractors (grade 4-6 or class C-D) respond inconsistent in bid/no bid decision and bid price decision. The differences variance in decision base on their current business strategies decision performance (See table).
- The small size contractor (grade 1-3 or class D-F) indicates intend to bid greater high price in competitive bidding (Table).
- The unknown contractor's registration with CIDB or PKK, they most probably will bid low price and depends on the depth of the relationship with the regular client and experience in the industry.
- The depth of the client relationship and experience in the industry may influence contractors to make their bidding decision (Table).

**Table. A comparative studies for the contractors' registration, pay off of bid/ no bid and bid price**

Contractor	Bid/No bid Payoff/ percentage (%)	Bid Price Payoff/ Variance
Contractor A	(17, 3) 85%	(25, 5) +20
Contractor B	(14, 6) 70%	(15, 15) +/- 0
Contractor C	(10, 10) 50%	(24, 6) + 18
Contractor D	(15, 5) 75%	(10, 20) -10

## 4.2 DECISION TREE

Decision tree is useful in arriving at the optimum decisions for complicated processes particularly when the decision problems are interrelated and sequential in nature. The decision tree concept is applicable to various problem areas, such as introduction of a new project, make or buy problems, investment decisions, marketing strategy, etc.

However, decision tree does not constitute the decision itself. It does not take the quantitative factors into account.

In a single stage decision problem the decision maker has to select the best course of action on the basis of whatever information is achievable at a point of time. But Sequential Decision problems involve multiple stages of decision. In analyzing multiple stages decision situations we have to evaluate the decision preceding in a backward manner by evaluating the best course of action at the later stages to decide the best action at the earlier stages. For this exercise a decision tree or a decision flow diagram, if drawn, becomes very helpful. A decision tree presents graphically, relevant information relating to a problem in the form of tree diagram, with branches (or forks) and nodes, so as to assist the management in decision making. The decision tree presents the set of all possible actions, i.e. the decision points that are known variables, the uncertain or chance events, the uncertainty associated with each chance event, estimated in terms of probability of each, and the costs and revenues of each chance event. The decision maker may choose the alternative that maximizes the expected profit, or the alternative that minimizes the expected cost at each decision point. He proceeds this way and ultimately reaches the best course of action from the beginning to the end.



A decision problem may also be represented with the help of diagram in the form of a tree, for clear and systematic idea. In this case alternative courses of action, states of nature, likely outcomes, etc. are diagrammatically or graphically depicted as if they are the branches, sub-branches of a horizontal tree. Hence it is known as a tree diagram.

The tree consists of a network of nodes, probability estimates, pay-offs.

A diagram that illustrates the chronological ordering of actions and events in a decision analysis problem is given below. Each act and event is depicted by a branch on the decision tree. Business problems always involve a long sequence of inter related actions and outcomes. Consider the case of a firm with a new product. The diagram below (a decision tree) gives a greatly simplified view of the structure of the managerial problems.

**4.2.1 Standard Symbols**

**Nodes:** There are two types of nodes -

- (i) decision node (symbolised as square) and
- (ii) chance node (marked as circle).

Alternative courses of action originate from decision node in main branches. Now, at the terminal point of decision node, chance node exists from where chance nodes emanate as sub-branches. Probability and outcomes are shown along these sub-branches. Each sub-branch can form branch again so that we can build a tree-like structure representing all possible outcomes.

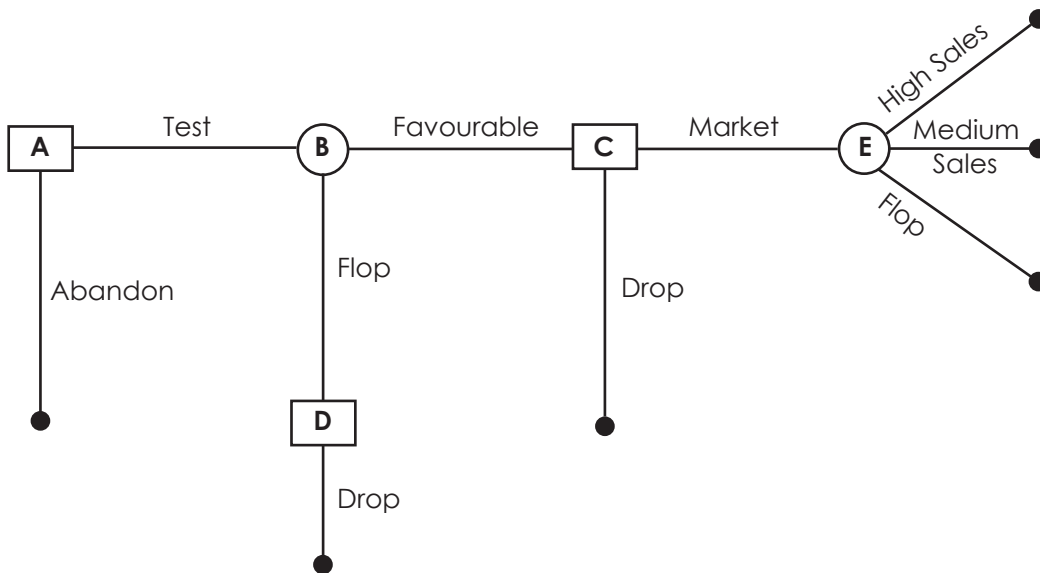

Above diagram describes below:

<b>Key A</b>	This is a <b>Decision Node</b> (Customarily shown as a square) in the tree. Here the decision is taken, either to test the product or to drop it.
<b>Key B</b>	This is an <b>Outcome Node</b> (Customarily shown as a circle). From this point action lines run to denote all possible outcomes of the action taken as a result of the preceding decision. In this case we are considering just two outcomes, one favorable and the other not.
<b>Key C</b>	Another decision node. The market test having proved favorable, management must decide whether now to go ahead with full marketing, or to drop the product.

<b>Key D</b>	Another decision node, but with no choice shown. In this example, the managerial policy is 'drop a product if the market test is unfavorable'.
<b>Key E</b>	Another outcome node. Filled in circles end nodes or terminations.

#### 4.2.2 Types of Decision Tree:

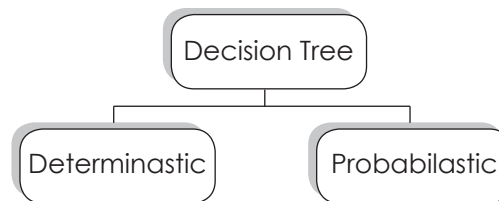

These again can be divided into single stage and multistage trees.

In a single stage decision tree we can find only one decision (*i.e.*, no chance event).

In a multistage decision tree, chains of decisions are to be made.

#### Illustration 7

There is 40% chance that a patient admitted to the hospital is suffering from cancer. A doctor has to decide whether a serious operation should be performed or not. If the patient is suffering from cancer and the serious operation is performed, the chance that he will recover is 70%, otherwise it is 35%. On the other hand, if the patient is not suffering from cancer and the serious operation is performed, the chance that he will recover is 20%, otherwise it is 100%. Assume that recovery and death are the only possible results.

Construct an appropriate decision tree. What decision should the doctor take?

#### Solution:

The decision tree has been constructed as follows :

Probability of recovery on operation =  $0.28 + 0.12 = 0.40$

Probability of recovery for no operation =  $0.14 + 0.60 = 0.74$

As  $0.74 > 0.40$ , so operation should not be done for recovery.

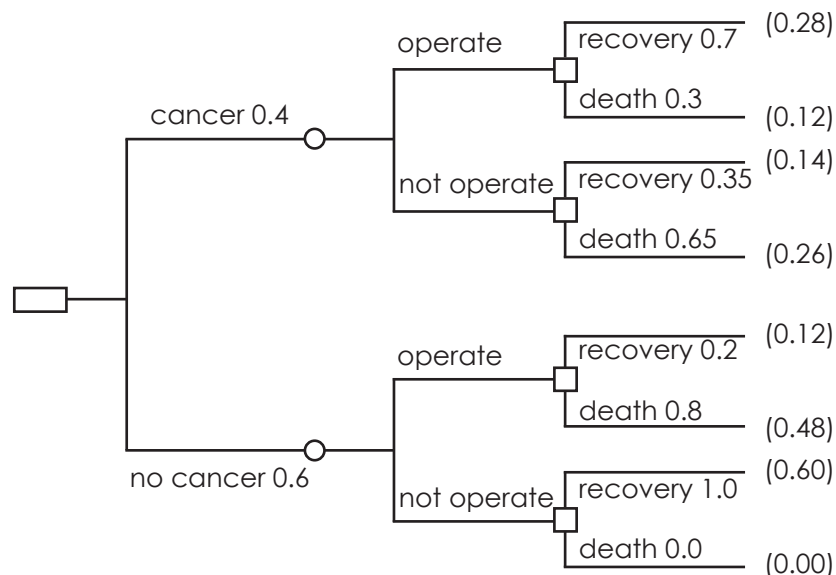

**Illustration 8**

A manufacturing company has to select one of the two products A or B for manufacturing. Product A requires investment of ₹ 20,000 and product B ₹ 40,000. Market research survey shows high, medium and low demands with corresponding probabilities and returns from sales, in ₹ thousand for the two products, in the following table :

Market Demand	Probability		Return from Sales	
	A	B	A	B
High	0.4	0.3	50	80
Medium	0.3	0.5	30	60
Low	0.3	0.2	10	50

Construct an appropriate Decision tree. What decision the company should take?

**Solution:**

Market Demand	A			B		
	x	P	Px	X	P	Px
High	50,000	0.4	20,000	80,000	0.3	24,000
Medium	30,000	0.3	9,000	60,000	0.5	30,000
Low	10,000	0.3	3,000	50,000	0.2	10,000
<b>Total</b>			<b>32,000</b>		<b>Total</b>	<b>64,000</b>

Product	Return (₹)	Investment (₹)	Profit (₹)
A	32,000	20,000	12,000
B	64,000	40,000	24,000

The company should take decision in favor of B since the profit is high.

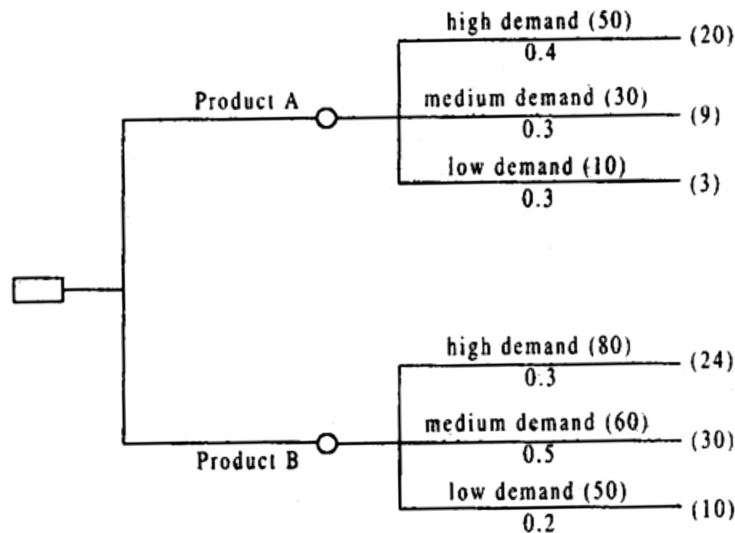

**Illustration 9**

A person has two independent investments A and B available to him; but he can undertake only one at a time due to certain constraints. He can choose A first and then stop, or if A is successful then take B or vice versa. The probability of success of A is 0.6 while for B it is 0.4. Both investments require an initial capital outlay of ₹10,000 and both return nothing if the venture is unsuccessful. Successful completion



of A will return ₹20,000 (over cost) and successful completion of B will return ₹24,000 (over cost). Draw decision tree and determine the best strategy.

**Solution:** The appropriate decision tree is as follows :-

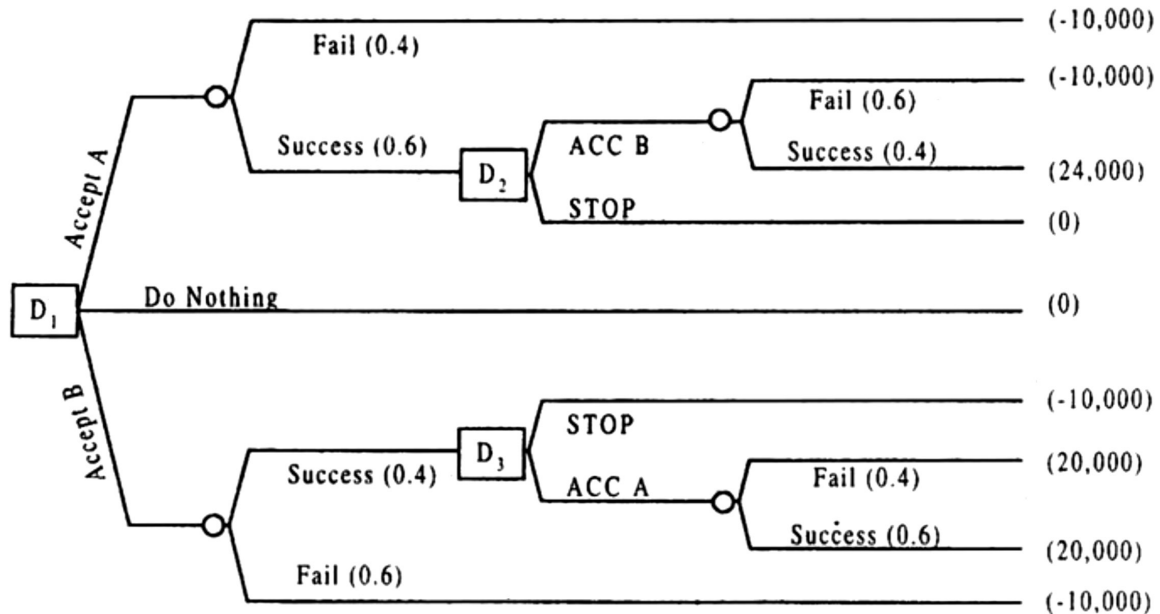

We find three decision points  $D_1$ ,  $D_2$ ,  $D_3$  in the above decision tree diagram. For analysis of the tree we start working backward.

### Evaluation of decision points

Decision Points	Outcome	Probability	Conditional Values	Expected Values
<b>D<sub>3</sub> (i)</b> Accept A	Success	0.6	20,000	12,000
	Failure	0.4	- 10,000	- 4,000
				8,000
<b>(ii)</b> Stop				0
<b>D<sub>2</sub> (i)</b> Accept B	Success	0.4	24,000	9,600
	Failure	0.6	-10,000	-6,000
				3,600
<b>(ii)</b> Stop				0
<b>D<sub>3</sub> (i)</b> Accept A	Success	0.6	20,000+3,600	14,160
	Failure	0.4	- 10,000	- 4,000
				10,160
<b>(ii)</b> Accept B	Success	0.4	24,000+8,000	12,800
	Failure	0.6	-10,000	-6,000
				6,800
<b>(iii)</b> Do Nothing				0

From the column of expected values above, we find the best strategy is to accept A and, if it is successful then accept B.

**Illustration10**

The Oil India Corporation is considering whether to go for an offshore oil drilling contract to be awarded in Bombay High. If they bid, value would be ₹ 600 million with a 65% chance of gaining the contract. They may set up a new drilling operation or move already existing operation, which has proved successful, to the new site. The probability of success and expected returns are as follows :

Out Come	New Drilling Operation		Existing Operation	
	Probability	Expected Revenue (₹ in million)	Probability	Expected Revenue (₹ in million)
Success	0.75	800	0.85	700
Failure	0.25	200	0.15	350

If the Corporation do not bid or lose the contract, they can use the ₹600 million to modernize their operation. This would result in a return of either 5% or 8% on the sum invested with probabilities 0.45 and 0.55.

(Assume that all costs and revenue have been discounted to present value)

- (i) Construct a decision tree for the problem showing clearly the course of action.
- (ii) By applying an appropriate decision criterion recommended whether or not the Oil India Corporation should bid the contract.

**Solution**

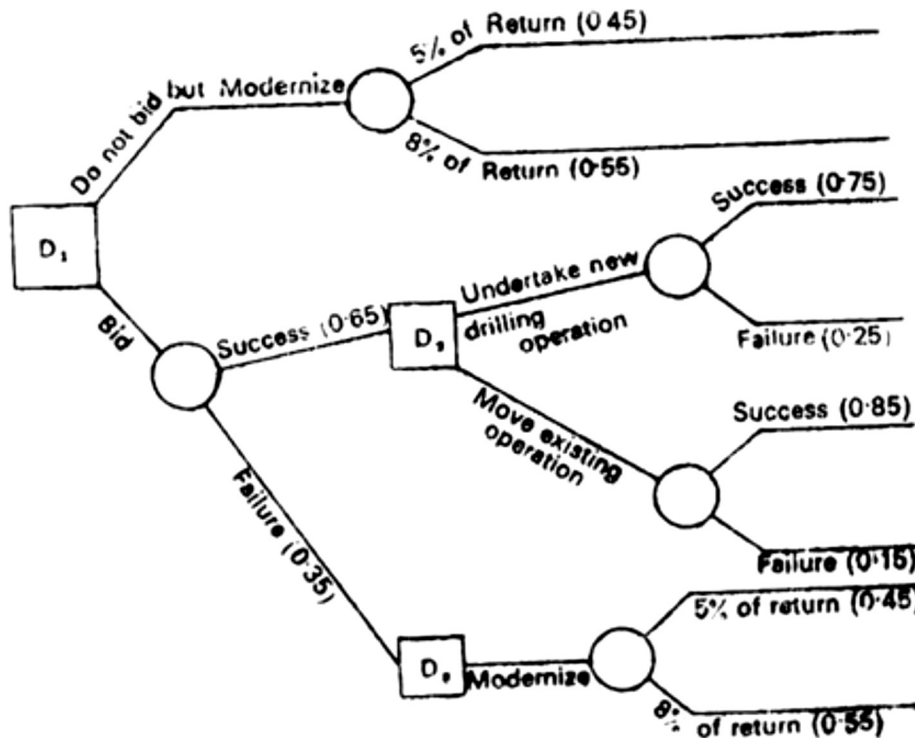

Evaluation of decision points



Decision Points	Outcome	Probability	Conditional Values (₹)	Expected Values (₹)
<b>D<sub>3</sub> (i)</b> Modernize	5% of Return	0.45	600 x 0.05	13.5
	8% of Return	0.55	600 x 0.08	26.4
				39.9
<b>D<sub>2</sub> (i)</b> Undertaken new Drilling new	Success	0.75	800	600
	Failure	0.25	200	50
				650
<b>(ii)</b> Move Existing Operation	Success	0.85	700	595
	Failure	0.15	350	52.5
				647.5
<b>D<sub>1</sub> (i)</b> Do not bid	5% of return	0.45	600 x 0.05	13.5
	8% of return	0.55	600 x 0.08	26.4
				39.9
<b>(ii)</b> Bid	Success	0.65	650 + 647.5	843.375
	Failure	0.35	39.9	13.965
				857.34
			<b>Less:</b>	600.00
			<b>Total</b>	257.34

The decision on the basis of EMV will be to bid and if successful establish a new drilling operation.

### Illustration 1

Matrix Company is planning to launch a new product, which can be Introduced initially In Western India or in the entire country. If the product is introduced only in Western India, the investment outlay will be ₹12 million. After two years, Matrix can evaluate the project to determine whether it should cover entire country. For such expansion it will have to incur an additional investment of ₹10 million. To introduce the product in the entire country right in the beginning would involve an outlay of ₹ 20 million. The product, in any case, will have a life of 5 years, after which the plant will have zero net value.

If the product is introduced only in Western India, demand would be high or low with the probabilities of 0.8 and 0.2 respectively and annual cash inflow of ₹ 4 million and ₹25 million respectively.

If the product is introduced in the entire country right in the beginning the demand would be high or low with probabilities of 0.6 and 0.4 respectively and annual cash inflows of ₹ 8 million and ₹5 million respectively.

Based on the observed demand in Western India, if the product is introduced in the entire country the following probabilities would exist for high and low demand on an all **India** basis

Western India	All India	
	High Demand	Low Demand
High Demand	0.90	0.10
Low Demand	0.40	0.60

The hurdle rate applicable to this project is 12 percent.

**(a)** Set up a decision tree for the Investment situation.

**(b)** Advice Matrix Company on the investment policy it should follow. Support your advice with appropriate reasoning.

Support your advice with appropriate reasoning

**Solution:**

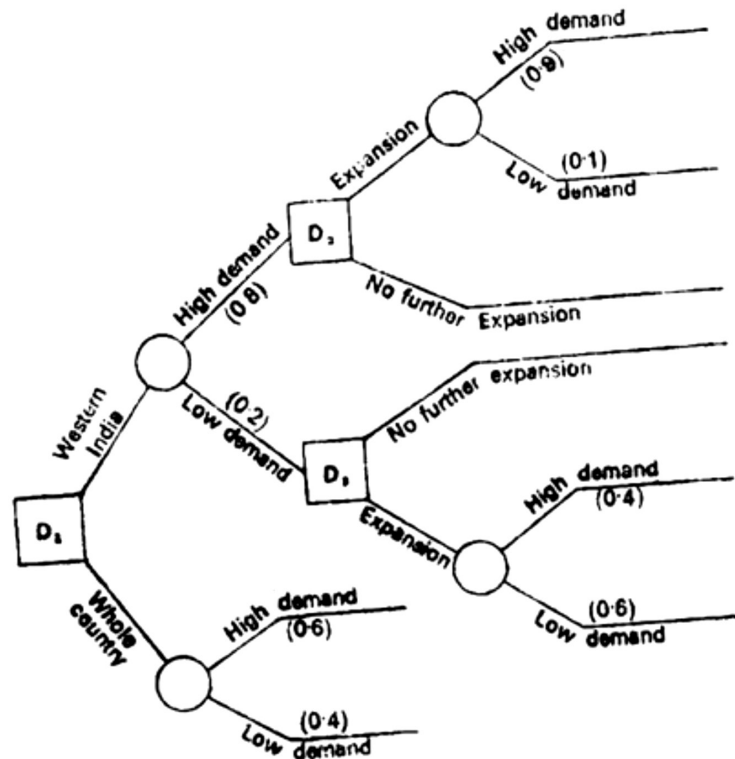

Evaluation of decision points

Decision Points	Outcome	Probability	Conditional Values (₹)	Expected Values (₹)
<b>D<sub>3</sub> (i)</b> Develop the new Product	Successful	0.5	105	52.5
	Failure	0.5	60	30.0
				82.5
<b>(ii)</b> Do not Develop ( decision at D <sub>2</sub> : go for developing the new product)	Success	0.5	35	17.50
	Failure	0.5	10	5.00
(a) Develop the new product				22.5
<b>(b)</b> Do not develop ( decision at D <sub>2</sub> : Do not develop the new product)				25.00
<b>D<sub>1</sub>(i)</b> Manufacture themself	(a) High Sales	0.1	82.50	8.25
	(b) Medium Sales	0.3	25.00	7.50
	(c) Low Sales	0.6	10.00	- 6.00
				9.75

(ii) Royalties	(a) High Sales	0.1	35.00	3.50
	(b) Medium Sales	0.3	20.00	20.00
	(c) Low Sales	0.6	10.00	6.00
				15.50
(ii) Sell all rights				15.50

(decision at  $D_1$  : Go for royalty).

Hence the overall decision is to go for royalty.

### 4.3 ATTITUDE TOWARDS RISK

#### 4.3.1 Indifference Curves and Attitudes to Risk

The attitudes to risk are reflected in different relationships between utility and income. However, it does not provide a direct measure of the riskiness of any particular course of action. The most common measure of the riskiness of an action, or the risk associated with a particular financial asset is the standard deviation of the returns accruing to it. When considering choices between alternative courses of action, decision makers may be thought of as deciding on different combinations of return on the one hand, measured by the expected value of the returns, and risk on the other, measured by standard deviation of those returns.

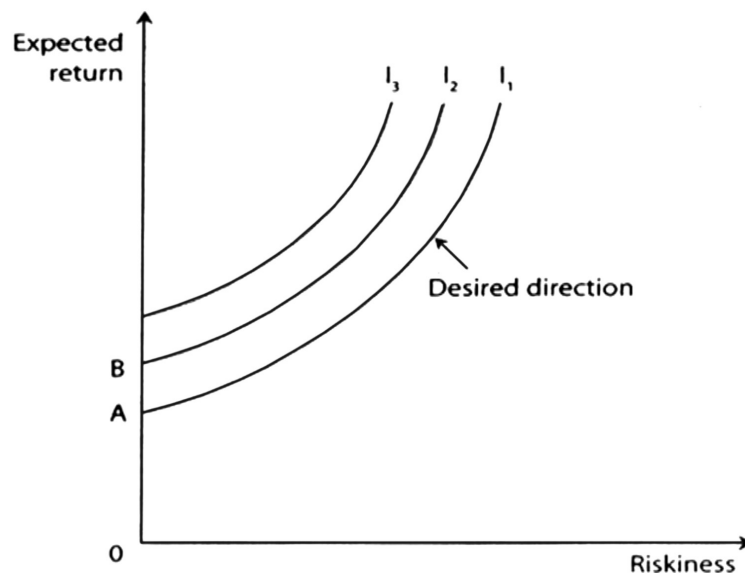

Indifference Curves for Risk and Return

#### 4.3.2 Concept of Certainty Equivalent

The most important application of risk versus return (or mean/variance) indifference analysis concerns the construction of portfolios of financial assets and therefore lie beyond the scope of the study. However there is one useful concept which should be noted is that the certainty equivalent of a course of action involving risk. This is defined as the sum of money, available with certainty, which would leave the decision-maker as satisfied as if he had undertaken the risky action. This may be interpreted, in terms of the indifference curves, as the vertical intercept of the curve which includes the course of action concerned. In above figure for instance, ₹A is the certainty equivalent of any combination of risk and return in the indifference curve  $I_1$  and ₹B is the certainty equivalent of any combination of curve  $I_2$ .



### 4.3.3 Assessing and Measuring Risk

Although individuals and companies are able to identify different types of risk, they have all faced difficulties with risk assessment and measurement. Risk assessment involves assessing the severity of a particular risk, its likelihood of occurrence, and the time frame in which the risk can occur. This approach helps in assigning weightages with regard to time and space parameters. Various techniques for measuring risk are discussed below:

### 4.3.4 Sensitivity Analysis

This technique is the one most adopted by analysts, both for short-term and long-term purposes. The approach of sensitivity analysis is based on the study of the impact of certain identified parameters on core performance over a period, either short-term or long-term.

In a budgetary exercise, which is essentially a short-term one, capacity utilization, price demand, etc., are taken separately as well as together to measure the impact of the variation in the parameter on profits/performance. For instance, when the break-even point (point of sales where no loss/profit occurs) is exceeded, all fixed costs are fully absorbed and contribution, namely selling price minus variable costs becomes profit. In other words, because the contribution is much higher than the profit margin, any increase in sales/ production beyond the break-even point increases the profit exponentially. Therefore, the variation in capacity utilization beyond the breakeven point needs to be fully analysed to augment profits. In the same manner, price elasticity and demand elasticity are factors that affect marginal costs and marginal profits. We need to understand the sensitivity of both.

In the long-term, sensitivity analysis identifies/focuses on such parameters that are sensitive to the passage of time, such as assumptions relating to statutory decisions, technological obsolescence, and product life cycles. In the case of statutory decisions such as control or decontrol of product prices, the sensitivity of strategic performance to such a change becomes an important factor of risk. For example, in the sugar industry that is partially controlled and is included as an essential commodity by the Government, any change in the Government's decision relating to price control becomes a risk and needs to be fully-understood. For this, sensitivity analysis portrays the impact of variation in the amount of price control on strategic performance of the company on a calibrated basis. Besides this, the impact of technological obsolescence, which again occurs due to the passage of time during which another technology is likely to emerge, will have to be assessed as a risk. In this case, sensitivity analysis measures the impact of risk on the basis of such obsolescence occurring in a time frame work calibrated for a particular purpose, say a major project.

Sensitivity analysis has also been extensively used to ascertain risk in terms of value relating the same to risk-adjusted expected value.

### Scenario Analysis

This is another technique that is frequently used by analysts to measure the impact of risks on strategic performance. However, this analysis is more qualitative than quantitative. This technique involves creating possible scenarios over the time span of strategy formulation and implementation delineating the impact of the specific parameters selected for analysis. For instance, Government decisions are known to impact corporate strategic performance in the form of availability of tax holidays, stimulus packages, duties and levies, etc. and these are identified as risks.

Scenario analysis works out the logic behind these Government decisions and also projects them over a period in the future. Subsequently, it is important to identify during the strategy implementation process, the impact of changes that occurred due to Government decisions.

### Decision Trees

This is yet another technique used for 'go' or 'no go' decisions when certain risks are encountered. A decision tree is essentially a support tool for making decisions and utilizes a tree-like model. The possible consequences including probability of event outcomes and resource utility can be computed under

this technique. This technique is commonly used in strategic management, projects, and operations research. It assists identification of the strategy most preferred for achieving a goal. In risk analysis, decision trees can be applied as a descriptive means for computing conditional probabilities. A decision tree uses three types of nodes, as follows:

Decision nodes — represented by squares

Chance nodes — represented by circles

End nodes — represented by triangles

A decision tree has splitting and not converging paths. Therefore, it grows with more alternatives and probabilities into a tree with several branches.

### **Monte Carlo Simulation**

The origin of these computerized mathematical techniques can be traced back to World War II, when the scientists working on the making of atom bomb used this model. This model provides a decision maker with a range of possible results and probabilities that would happen for any choice of action. This simulation includes two extremes, namely, the scenario of total failure and that of the most conservative decision. Along with all the middle values of possible consequences, this technique operates on the basis of developing risk analysis through models for possible results by substituting a range of values in a probability distribution for any parameter that has inherent uncertainty.

The model goes on to calculate the results through iteration using different sets of random values from the probability function every time. This simulation may have to perform myriads of calculations depending on the number of uncertain parameters with different ranges. Finally, this simulation offers possible outcome values.

Probability distributions can be any of the following:

**Normal distribution or 'Bell curve':** This distribution defines the mean or the expected value and a standard deviation to describe the variation from the mean. As it is symmetric, it is able to describe many natural occurrences or properties such as height, weight, etc. Examples of parameters included in normal distributions are inflation rates and energy prices.

**Uniform:** When occurrences have equal chances, then it is enough to define the minimum and maximum. Examples of these variables include manufacturing costs or projected earnings.

**Triangular:** This application defines the minimum most likely and the maximum values. Most likely values are those most likely to occur. This application is normally applied for a triangular distribution, such as the relationship between past sales, a specific time interval, and inventory levels.

**PERT:** Programme Evaluation Review Technique (PERT) is somewhat like the triangular distribution defining the minimum, most likely, and maximum values. An example of PERT distribution is the computation of duration for an activity in a project.

**Log normal:** When symmetry is not available in a distribution and values are positively skewed, this method is applied to compute values that are above zero but have infinite positive potential. These approaches are normally applicable to real estate property values, stock prices, mineral reserves, etc.

**Discreet:** The user adopts specific value that may happen and the likelihood of such values. For instance, results of an action can be analysed with a 30 per cent chance of positive outcome, 30 per cent chance of negative outcome and 20 per cent of a neutral outcome, and a 20 per cent chance of failure.

The essence of a Monte Carlo simulation is that values are sampled at random from the input probability distributions. Each set of such samples is identified for iteration and the result is recorded. These iterations are carried on thousands of times resulting in a probability distribution of possible outcomes. In short, Monte Carlo simulation indicates that event could happen and how likely it is to occur.

The advantages of this technique over other methods is that it provides a range of possibilities as follows:

**Correlation of inputs:** The interdependence of relationship between input variables can be cast into a model. It will help analysts to understand how the factors behave in a directly proportional, inversely proportional or otherwise correlated relationship.

**Sensitivity Analysis:** Sensitivity analysis is also adopted in deterministic situations whereas Monte Carlo allows for measuring different impacts of the variables, as also identifying the factor which affects the outcome the most and which affects it the least.

**Graphical Analysis:** The data available from this simulation can be pictorially represented in the form of various graphs to communicate the findings in a comprehensive manner.

**Scenario Analysis:** This is again an application which is normally taken up under deterministic situations. However, under Monte Carlo simulation the main point of a scenario analysis is to find out how exactly the relationship between inputs and outputs vary. Such a tool also helps to model different combinations of values for different parameters to gauge the impact under varying scenarios.

Monte Carlo simulation finds great utility in real-life applications especially in management decision situations. First, assumptions regarding the distributions in respect to severity and frequency of individual losses are made. Then the samples are randomly drawn from each distribution to calculate the total losses under different strategies of risk management. Following this, a few hundred iterations are performed to define a distribution for total losses under each alternative. A comparison of such distributions greatly helps decision-making.

#### 4.3.5 Certainty Equivalent

A risk-averse individual or company always wants to gauge the degree of risk and compute a return correspondingly as a compensation for the additional risk. Normally, a risk-free rate of return is available to any individual on a safe deposit of monies with the Government for a minimum return. Any reinvestment of such monies with a higher degree of risk would have to compensate for the incremental risk. This is known as a risk premium and is defined as the minimum differential that an investor requires to part with his stake. The certainty equivalent is the guaranteed compensation and it is the amount of expected 'pay-off less risk premium'.

As per the dictionary certainty equivalent has been defined as the amount of payoff, such as money or utility that an individual would have to receive to be indifferent between that pay off and a given gamble. For a risk-averse person, the certainty equivalent is less than the expected value of the gamble as the individual prefers to reduce uncertainty.

Applying the risk premium concept to the two types of securities, namely, equity and debt, the definitions are given below:

- In a stock market, risk premium is the difference between the expected returns from a stock minus the risk free rate.
- The return from equity is a combination of dividend yield and capital gains. A stock market always takes into consideration the two factors and reflects the risk premium to a corresponding prevalent risk free rate.
- In the case of debt, the risk premium is the difference between bond interest rate and risk-free rate and sometimes it is also referred to as credit spread.

This method has application not only in regard to the investments in securities but also in relation to risks involved in individual projects, and in comparison of different projects for ranking purposes. A certain probability coefficient is attached to each outcome and the net present value is computed for each outcome. The value of certainty equivalent coefficient is a summation of such coefficients

with the respective weightage of each probability. The value of this certainty equivalent coefficient ranges between zero and one. A value of one indicates absolute certainty and as such the risk is neutral. Certainty equivalent coefficient varies with the different types of investments and is inversely proportional to risk. Higher the risk, the certainty coefficient is lower. For instance, certainty equivalent coefficient is higher for a replacement investment as against a new product investment.

#### 4.3.6 Risk Adjusted Discount Rate Method

This method is very much akin to certainty equivalent method that is more popular. This is due to the fact that quantification of the risk premium is more concrete in this method. Normally when new investments have the same risk as existing operations, the discount rate applied is the average cost of capital of the operations. If the risk of the new project is greater, then a formula is applied for the computation of the risk adjusted discount rate, as follows:

$$r_p = r_f + n + d_p$$

where,

$r_p$  = Risk adjusted discount rate for project 'p'

$r_f$  = Risk free rate of interest

$n$  = Premium for normal risk

$d_p$  = Premium for additional risk differential for project 'p'

The risk premium so computed is based on the perception regarding the project risk and risk-return preference. Such premiums are normally calculated by comparing the returns obtained from different investments currently. The risk premium, normally varies between one per cent to 10 per cent, based on the risk assessment of such investments.

The offshoot of this method is the Risk Adjusted Return on Capital (RAROC). This computation is a risk-based profitability measurement framework for understanding the risk adjusted financial performance and providing an appropriate view. This concept was developed by Dan Borge in the late seventies. The RAROC can be represented as follows:

RAROC = Expected return/Economic capital or

RAROC = Expected return/Value at risk

#### 4.3.7 Utility Function and Risk Taking

Common investors will have three possible attitudes to undertake risky course of action (i) an aversion to risk, (ii) a desire to take risk, and (iii) an indifference to risk. The following example will clarify the risk attitude of the individual investors.

State of economy	Possible outcome	
	X	Y
Recession	90	0
Normal	100	100
Boom	110	200

If we assume that the three states of the economy are equally likely, then expected value for each alternative is ₹100.

- (i) A risk seeker is one who, given a choice between more or less risky alternatives with identical expected values, prefers the riskier alternative i.e., alternative Y.
- (ii) A risk averted would select the less risky alternative i.e., alternative X.
- (iii) The person who is indifferent to risk (risk neutral) would be indifferent to both alternative X and Y,

because they have same expected values.

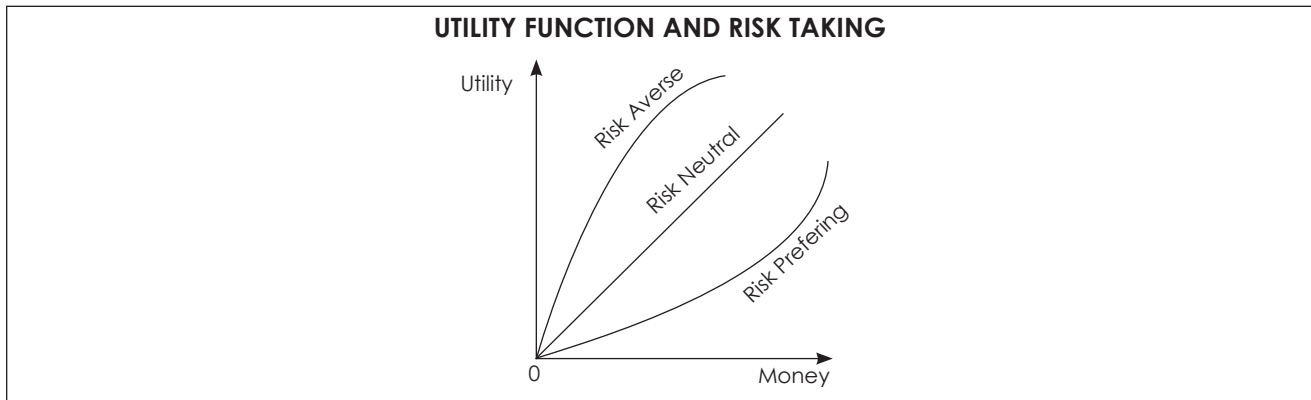

The investors' attitude towards risk can be formalized by use of indifference curves which shows the tradeoff between risk and return. Indifference curves show the risk-return indifference for a hypothetical investor. All the points lying on a given indifference curve offer the same level of satisfaction. In this case, indifference curves can be drawn up, showing the different combinations of risk and return which will leave an individual equally satisfied. If individuals are assumed to be risk-averse, which is the assumption generally made then the indifference curves will be rising from left to right, with the more desirable combinations being as indicated by the arrow, having higher returns and lower risk. The extent of an individual's risk aversion will be reflected in the slopes of the indifference curves. An individual who is very highly risk averse will be prepared to sacrifice a large amount of return in order to secure a small reduction in risk and will therefore have relatively steep indifference curves, relative to one who is only slightly risk averse. A risk neutral individual will have horizontal indifference curves. For a risk lover, for whom both risk and return are desirable characteristics, the curves will slope downwards from left to right, rather than in the other direction.

The above figure shows utility functions. On this graph, person maximizes utility by maximizing EMV. Therefore, EMV, may be a useful decision criterion in the range in which the utility function is linear. But when there are large variations in the amount of money, i.e., large losses or gains at issue, the utility function ceases to be linear.

#### 4.4 EXPECTED VALUE OF PERFECT INFORMATION

##### Introduction:

The expected value of perfect information is the expected return in long run, provided there is perfect information before decision taken. In the case of decision making under Uncertainty the probabilities associated with the different states of nature are unknown. Moreover, there is no previous data or information available which could allot the probability of the occurrence of states of nature. As such, the decision maker cannot calculate the expected pay off for the course of action. The decision maker faces problems when he desires to introduce new plant or production. A number of decision maker may choose any of the following:



**(i) Maximin:**

The course of action that maximizes the minimum possible pay-off is selected. The decision maker lists down the minimum outcome within each course of action (or act) and then selects the strategy with the maximum number.

This is also known as a Pessimistic Decision criterion as it located the strategy having least loss.

Refer Example 1, the row minimums of the different courses of action are :

$a_1$	40	By this criterion the choice will be $a_1$ which has the maximum pay off amongst all the minimums of four acts.
$a_2$	36	
$a_3$	32	
$a_4$	28	

**(ii) Maximax**

In this case the course of action that maximizes the maximum pay-off is taken. The decision maker lists down the maximum pay-off associated with each course of action, then selects that alternative having maximum number.

This may be called an **Optimistic Decision Criterion** as the decision maker selects the alternative of highest possible gain.

In the example as mentioned above, the maximum pay-off of each course of action is

$a_1$	40	Since the course of action $a_4$ has the maximum pay-off, so the decision maker will select this alternative.
$a_2$	42	
$a_3$	44	
$a_4$	46	

**(iii) Minimax Regret**

The regrets (i.e. opportunity loss) for each course of action are to be calculated with reference to the least pay-off of various alternative acts. Now obtain the maximum regret and hence select course of action with the minimum of the maximum regret values.

Refer the loss table given in Ex. 1.

State of nature → Acts ↓	(20) S <sub>1</sub>	(21) S <sub>2</sub>	(22) S <sub>3</sub>	(23) S <sub>4</sub>	Maximum Regrets
(20) a <sub>1</sub>	40-40 = 0	42-40=2	44-40=4	46-40=6	6
(21) a <sub>2</sub>	40-36 = 4	42-42=0	44-42=2	46-42=4	4
(22) a <sub>3</sub>	40-32 = 8	42-38=4	44-44=0	46-44=2	8
(23) a <sub>4</sub>	40-28=12	42-34=8	44-40=4	46-46=0	12

Thus the minimum amongst the maximum regrets is in a<sub>2</sub>.

**(iv) Hurwitz criterion (or Criterion of Realism)**

This criterion makes compromise between maximax and maximin i.e., an Optimistic and Pessimistic decision criterion. At first, a coefficient of optimism is selected, which is assumed to be degree of optimism. Now, according to Hurwitz, select that alternative which maximizes.

$$( \text{maximum pay - off} ) + ( 1 - ) (\text{minimum pay - off})$$

**Illustration12**

Choose the product applying Hurwitz method with coefficient of optimism= 0.60 from the following data :

**(Profit in ₹ ' 000)**

State of nature → Acts ↓	Good	Fair	Poor
Product A	10,000	8,000	2,000
Product B	12,500	9,000	- 1,000

**Solution :**

Maximum and Minimum Pay - off are tabulated for each act

	Maximum Value	Minimum Value
Product A	10,000	2,000
Product B	12,500	- 1,000

$$AS = 0.6 , \text{ So, } (1-) = 1- 0.6 = 0.4$$

We have for

$$\text{Product A : } 10000 \times 0.6 + 2000 \times 0.4 = 6800$$

$$\text{Product B : } 12500 \times 0.6 + (- 1000) \times 0.4 = 7100$$

As the expected value of Product B is higher, so Product B should be accepted.

**(v) Criterion of rationality**

This criterion is based on the principle of equal likelihood. The decision maker first calculates the average outcome for each course of action and then selects the maximum number.

$$\text{Average outcome is } \frac{1}{n} (O_{i1} + O_{i2} + \dots + O_{in})$$

### Illustration 13

Events → Acts ↓	S <sub>1</sub>	S <sub>2</sub>	S <sub>3</sub>
A <sub>1</sub>	400	600	200
A <sub>2</sub>	650	800	-100
A <sub>3</sub>	400	500	60

#### Solution:

Average for :-

A <sub>1</sub>	1/3 (400+600+200)	= 400
A <sub>2</sub>	1/3 (650+800-100)	= 450
A <sub>3</sub>	1/3 (400+500+60)	= 320

Here the choice is for A<sub>2</sub>.

#### (vi) Laplace Principle

The Laplace Principle is based on the simple philosophy that if we are uncertain about the various events then we may treat them as equally probable. Under this assumption, the expected (mean) value of pay-off for each strategy is determined and the strategy with highest mean value is adopted. Of course, if the pay-offs are in terms of costs, we choose the strategy with the lowest average cost.

For Example expected pay-offs for different acts are as follows:

Act	Mean (Expected) Pay-off	Results
A <sub>1</sub>	(360 + 360 + 360 + 360 + 360 + 360)/6	= ₹ 360.00
A <sub>2</sub>	(310 + 380 + 380 + 380 + 380 + 380)/6	= ₹ 368.30
A <sub>3</sub>	(260 + 330 + 400 + 400 + 400 + 400)/6	= ₹ 365.00
A <sub>4</sub>	(210 + 280 + 350 + 420 + 420 + 420)/6	= ₹ 350.00
A <sub>5</sub>	(160 + 230 + 300 + 370 + 440 + 440)/6	= ₹ 323.30
A <sub>6</sub>	(110 + 180 + 250 + 320 + 390 + 460)/6	= ₹ 285.00

Since the expected pay-off for A<sub>2</sub> is the maximum, it would be adopted.

### Illustration 14

A pig breeder can either produce 20 or 30 pigs. The total production of his competitors can be either 5,000 or 10,000 pigs. If they produce 5,000 pigs, his profit per pig is ₹ 60; if they produce 10,000 pigs, his profit per pig is only ₹ 45. Construct a pay-off table and also state what should the pig breeder decide.

#### Solution:

With the given data let us construct the pay-off table :-

State of nature → Acts ↓	5,000	10,000
A <sub>1</sub> (20)	20 x 60 = 1,200	20 x 45 = 900



<b>A<sub>2</sub> (30)</b>	30 x 60 = 1,800	30 x 45 = 1,350
---------------------------	--------------------	--------------------

Assuming the pig breeder to be conservative, we use Maximin approach. As such, the minimums of act A<sub>1</sub> is 900 and that of A<sub>2</sub> is 1350, which is, of course, maximum. So the pig breeder should accept the course of action A<sub>2</sub>.

Further, by Maxi max approach also 1800 is maximum which also corresponds to A<sub>2</sub>

#### 4.4.1 Expected Monetary Value Criterion (EMV)

For decision problems involving risk situations one of the most popular method is the **Expected Monetary Value** of expected pay off. Given a pay off (decision) table with conditional values (pay offs) and probability assessments for all events or states of nature, it is possible to determine the Expected Monetary Value (E.M.V) for each alternative which is just the sum of possible pay offs of the alternative, each weighted by the probability of that Payoff occurring. The objective should be to optimize the expected payoff, which may mean either maximization of expected profit or minimization of expected profit or minimization of expected regret.

The formula expressed below:

$$EMV (A_i) = p_{i1} P(E_1) + p_{i2} P(E_2) + p_{i3} P(E_3) \dots + p_{in} P(E_n)$$

##### Note:

Usually, the conditional values (Payoffs) are measure in monetary units and hence the expected pay-off in the context of decision theory is referred to as the **Expected Monetary Values (EMV)**. The various steps involved are listed below:

- (i) Construct payoff table listing the acts (alternative strategies and events / states of nature). This table considers the economics of the problem by calculating a conditional payoff value for each act and even combination.
- (ii) Assign probabilities to the various events, making sure that the events exhaust all possible alternatives, i.e. the probabilities add to end.
- (iii) Calculate an EMV for each act by multiplying (weighting) the conditional values (payoff) by the assigned probabilities and add the resulting weighting conditional values to obtain EMV of the act.
- (iv) Choose, as the optimal act, that act with the highest EMV.

##### Illustration15

Given is the following Pay - off matrix

Course of action

State of Nature	Probability	Do not expand (₹)	Expand 200 units (₹)	Expand 400 units (₹)
High Demand	0.4	2,500	3,500	5,000
Medium Demand	0.4	2,500	3,500	2,500
Low Demand	0.2	2,500	1,500	1,000

What should be the decision if we use : Expected Monetary Value Criterion.

**Solution:**

State of Nature →	High Demand	Medium Demand	Low Demand
Probability	0.4	0.4	0.2
Course of Action ↓			
Do not Expand ( $A_1$ )	2,500	2,500	2,500
Expand 200 units ( $A_2$ )	3,500	3,500	1,500
Expand 400 units ( $A_3$ )	5,000	2,500	1,000

Expected Monetary Value :

Course of Action	Calculation	EMV (₹)
$A_1$	$0.4 \times 2,500 + 0.4 \times 2,500 + 0.2 \times 2,500 =$	2,500
$A_2$	$0.4 \times 3,500 + 0.4 \times 3,500 + 0.2 \times 1,500 =$	3,100
$A_3$	$0.4 \times 5,000 + 0.4 \times 2,500 + 0.2 \times 1,000 =$	3,200

#### 4.4.2 Expected Opportunity Loss or Expected Regret

The expected opportunity loss or expected regret criterion is another basis on which a decision may be taken. As we shall observe, this criterion leads to the same conclusion as the expected pay-off criterion.

If  $P(S_1)$ ,  $P(S_2)$  .....  $P(S_n)$ , be the Prior probabilities corresponding to the respective states of nature  $S_1$ ,  $S_2$  .....  $S_n$ , then Expected Opportunity Loss (EOL) to act.

$$A_1 = (M_1 - P_{11}) P(S_1) + (M_2 - P_{12}) P(S_2) + \dots + (M_n - P_{1n}) P(S_n)$$

Same way we express the rest of course of action i.e.  $A_2$  and  $A_3$  etc.

#### For say example

Refer the above illustration, the EOL is Act  $A_1$ . The minimum of the act.

#### 4.4.3 Expected Value of Perfect Information (EVPI)

The expected value with perfect information is the expected or average return, in the long run, if we have perfect information before a decision has to be made.

#### Calculation

$$EVPI = EPPI - \text{Maximum EMV}$$

Where, EPPI = Expected payoff with perfect information.

For calculation of EPPI = (maximum payoff in the 1st state of nature) x (probability of 1st nature) + (maximum pay off in 2nd state) x (probability of that state) + .....up to last state.

**Illustration 16**

Pay offs of three acts A, B and C and states of nature X, Y and Z are given below :

**Payoff (in ₹)**

Acts → State of Nature ↓	A	B	C
X	-20	-50	200
Y	200	-100	-50
Z	400	600	300

The probabilities of the states of nature are 0.3, 0.4 and 0.3.

Calculate the Expected Monetary Value (EMV), for the above data and select the best act. Also find the EVPI.

**Solution:**

Let us find the Expected Monetary Value (EMV) of each act.

$$\text{Act A} = -20 \times 0.3 + 200 \times 0.4 + 400 \times 0.3 = ₹ 194$$

$$\text{Act B} = -50 \times 0.3 - 100 \times 0.4 + 600 \times 0.3 = ₹ 125$$

$$\text{Act C} = 200 \times 0.3 - 50 \times 0.4 + 300 \times 0.3 = ₹ 130$$

EMV of Act A is highest as seen in the table , so it should be selected.

State of nature	Prob	A	B	C	Max for state of nature	Max pay off x Prob.
X	0.3	-20	-50	200	200	$200 \times 0.3 = 60$
Y	0.4	200	-100	-50	200	$200 \times 0.4 = 80$
Z	0.3	400	600	300	600	$600 \times 0.3 = 180$
<b>Total</b>						320

$$\text{EVPI} = \text{Expected pay-off with perfect information (EPPI)} - \text{EVI} = 320 - 194 = ₹ 126$$

**Illustration 17**

Chemical Products Ltd. produced a compound which must be sold within the month it is produced, if the normal price of ₹ 100 per drum is to be obtained. Anything unsold in that month is sold in a different market for ₹ 20 per drum. The variable cost is ₹ 55 per drum.

During the last five years , monthly demand was recorded and showed the following frequencies :

Monthly Demand (no. of drums)	2,000	3,000	6,000
Frequency	24	12	24

1. Prepare an appropriate pay off table.
2. Advise the production management on the number of drums that should be produced next month.



**Solution:**

**Gain (on sale)** =  $100 - 55 = 45$ , **Loss (for unsold)** =  $55 - 20 = 35$

Demand →	2,000	3,000	6,000	Expected Value
Prob	$24/60 = 0.4$	$12/60 = 0.2$	$24/60 = 0.4$	
Stock ↓				
2,000	$2,000 \times 45 = 90,000$	90,000	90,000	$90,000 \times 0.4 + 90,000 \times 0.2 + 90,000 \times 0.4 = 90,000$
3,000	$90,000 - 35,000 = 55,000$	$3,000 \times 45 = 1,35,000$	$1,35,000 - (3,000 \times 35) = 30,000$	$55,000 \times 0.4 + 1,35,000 \times 0.2 + 30,000 \times 0.4 = 61,000$
6,000	$90,000 - (4,000 \times 35) = -50,000$	$1,35,000 - (3,000 \times 35) = 30,000$	$6,000 \times 45 = 2,70,000$	$-50,000 \times 0.4 + 30,000 \times 0.2 + 2,70,000 \times 0.4 = 94,000$

Since the expected value is highest ( ₹ 94,000) for 6,000, so in the next month number of drums in stock should be 6,000.



# Study Note - 5

## ECONOMIC EFFICIENCY OF THE FIRM - IMPACT ANALYSIS ON PERFORMANCE



### This Study Note includes

- 5.1 Profit Maximization under Different Market Structure
- 5.2 Pricing Policies
- 5.3 Product Policies

### 5.1 PROFIT MAXIMIZATION UNDER DIFFERENT MARKET STRUCTURE

For about a century, the assumption that a firm maximizes profit (total revenue minus total cost) has been at the forefront of neoclassical economic theory. This assumption is the guiding principle underlying every firm's production. An important aspect of this assumption is that firms maximize profit by setting output where Marginal Cost (MC) equals Marginal Revenue (MR). This equality holds regardless of the market structure under study that is, perfect competition, monopoly, monopolistic competition, or oligopoly.

While the implications of profit maximization are different for different market structures, the process of maximizing profit is essentially the same. The problem for the firm is to determine where to locate output, given costs and the demand for the product to be sold.

#### 5.1.1 Profit Maximization

Profits = Total Revenue - Total Costs

Total Revenue = Price x Quantity

Total Cost = Average Total Cost x Quantity

**Therefore,** Profit = (Price x Quantity) – (Average Cost x Quantity)

Profit = (Price – Average Cost) x Quantity

In managerial economics, thus, there are two interpretations of profit:

- (1) Economic Profit
- (2) Accounting Profit

**Economic Profit** = Total Revenue - Total Economic Cost  
= Total Revenue - (Total Explicit Cost + Total implicit Costs)

**Accounting Profit** = Total Revenue - Total Explicit Cost

#### 5.1.2 Normal Profit

It refers to that amount of earnings which is just sufficient to induce the firm to stay in the industry. Normal profit is, thus, the minimum reasonable level of profit which the entrepreneur must get in the long run, so that he is induced to continue the employment of his resources in its present form.

Normal profit is the opportunity cost of entrepreneurship. It is equivalent to the transfer earnings of the entrepreneur. That means, if the entrepreneur fails to earn the normal rate of profit in the long run, he will close down the operation of his firm and quit the industry in order to shift his resources elsewhere.

Normal profit is considered as the least possible reward which in the long run must be earned by the entrepreneur, as compensation for his organizational services as well as for bearing the insurable business risks.

Normal profit is always regarded as a part of factor costs. Since entrepreneurial service is a factor of production, the price paid for it is the normal profit and it is to be incorporated while calculating the total cost. Of course, normal profit is the implicit money cost. Thus, in the economic sense, when the total cost (Q) is measured, it also covers the normal profit of the firm. As such, when  $R = C$ , ordinarily it will be inferred that there is no profit. In the economic sense, though we may say, there is no pure business profit, but there is normal profit, which is already embedded in the total cost.

It must be remembered that the entrepreneur desires a fixed amount as normal profit, which is independent of the output. So, normal profit as a factor cost is a fixed implicit cost element. Evidently, when output expands, total normal profit like *TFC* gets spread over the range of output. This has a bearing on the shape of the average cost curve (*AC*), as shown in following Figure.

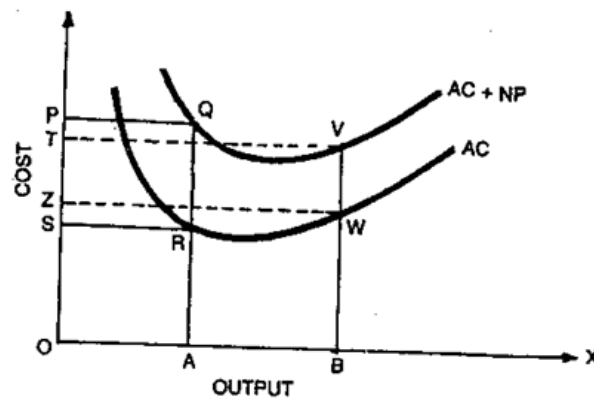

Following Stonier and Hague (1966), in above Figure, we have drawn two *AC* curves, one excluding normal profit-cost element (*AC*) and another by including it (*AC + NP*). It may be observed that as we move from left to right, the vertical distance between *AC* and *AC + NP* curves tend to become narrow in a steady manner. This implies that as output increases, normal profit per unit of output, diminishes. However, the total normal profit at all levels of output remains the same. Geometrically, thus, when output is *OA*, the average normal profit is *QR*. When output rises to *OB*, the average normal profit diminishes to *VW*. Total normal profit is *PQRS* in the former case and *TVWZ* in the latter case. However,  $PQRS = TVWZ$ .

Normal profit is measured by the difference between *AC + NP* and *AC* curves. In economic theory, thus, whenever the average cost curve is drawn, the normal profit as the factor cost element of a fixed nature is always included; hence, *ATC* curve means *AC + NP* curve.

A theoretical importance of the concept of normal profit is for determining the industry's equilibrium. When only normal profit is earned by the existing firms there will be no new entry in the competitive market or the industry.

### 5.1.3 Supernormal Profit

Profits in excess of normal profit are considered as supernormal. Since normal profit is included in the cost of production, supernormal profit is obtained when total revenue exceeds total costs (*i.e.*,  $TR > TC$ ). It is also called pure business profit or "excess profit."

Supernormal profit depends on the demand conditions in the business, which are uncertain and unpredictable. Thus, supernormal profit is the reward for bearing uncertainties and unpredictable risks of business. Sometimes, in a competitive market, supernormal profit is also earned due to extraordinary efficiency on the part of the entrepreneur.

When the existing firms earn supernormal profit, new entries will be attracted to the industry, so the equilibrium of the industry is threatened.

Incidentally, when  $TR > TC$ , such that only a part of normal profit is earned by the firm, it is called subnormal profit. Subnormal profit is the profit below the normal profit earned when total revenue covers up explicit costs fully and a part of implicit cost of entrepreneurial services.

### 5.1.4 Marginal Cost, Marginal Revenue

Marginal cost = Change in Total cost / Change in quantity

Marginal cost intersects average total cost and average variable cost curves at the minimum points because for each additional change in cost, there will be a corresponding (but not necessarily equal) change in average variable costs.

Marginal Revenue = Change in total revenue / change in quantity sold

All efficient firms, whether monopoly or competitive, will set quantity where marginal revenue equals marginal cost.

An informative and useful method of determining a firm's equilibrium output is the comparison of Marginal Cost (MC) with Marginal Revenue (MR) at each successive unit of output, instead to Total Revenue (TR) and Total Cost (TC).

Market price per unit (P)	Units of output sold (Q)	Total Revenue (TR = PQ)	Total Cost (TC)	Profit /loss (TR - TC)	Marginal Revenue (MR)	Marginal Cost (MC)
10	0	0	10	-10	0	0
10	1	10	16	-6	10	> 6
10	2	20	20	0	10	>4
10	3	30	21	+9	10	>1
10	4	40	22	+18	10	>1
10	5	50	25	+25	10	>3
10	6	60	30	+30	10	>5
10	7	70	37	+33	10	>7
10	8	80	47	+33	10	=10
10	9	90	61	+29	10	<14
10	10	100	81	+19	10	<20

### 5.1.5 Profit maximization under conditions of perfect competition

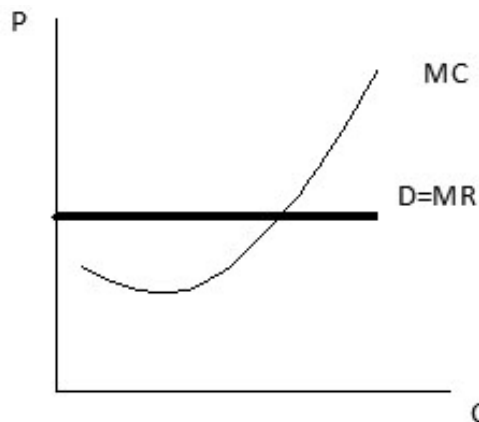

A perfectly competitive market is characterized by many sellers, many buyers, relatively easy entry into and from a market, standardized products, and perfect information. Perfectly competitive firms operate at lowest cost, lowest price.

Perfectly competitive firms are price TAKER Therefore, the demand curve facing the individual firm is horizontal. Because price does not change, and because  $TR = P \times Q$  and  $MR = dTR / dQ$ , then  $P = MR$ .

Perfectly competitive firms will operate or produce where  $P = MR = MC$ . At this point, the firm maximizes profits and minimizes losses.



Conditions necessary for optimal allocation of resources

1. Market goods are marketable, divisible
2. Distribution is not a problem
3. Goods and services are perfect substitutes
4. Perfect information
5. Perfect competition

Absence of any of these conditions can cause **market failure**.

### 5.1.6 Profit Maximization under Conditions of Monopoly

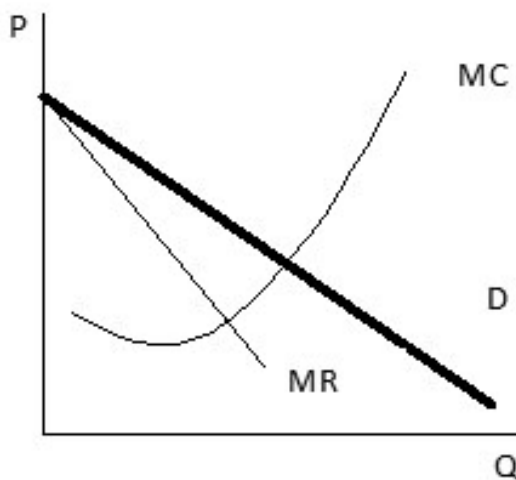

Monopoly markets are characterized by one seller. Barriers to entry and exit, patents, control over resources or economies of scale can result in monopolistic conditions.

Economies of scale mean that the more the firm produces, the less costly the production becomes. Economies of scale often benefit consumer.

Monopolies are price MAKER. This means that the monopoly faces the market demand curve. A monopoly can command any price or set any level of quantity so long as it meets demand, but the most efficient point of operation will be at the point where  $MR=MC$ . Price will generally be set higher, however.

The monopolist will restrict output in order to maximize profit. By keeping prices high and quantity low, the monopolist disturbs the balance of conditions necessary for market

clearing to occur. Allocation is therefore sub-optimal.

"Natural monopolies" are able to supply the entire market at a lower cost per unit than would be achieved by two or more firms supplying it. They often experience economies of scale.

### Profit Maximisation Problem: A Hypothetical Case Study

A practical significance of marginal analysis is highlighted by the following hypothetical business problem on profit-maximisation. Sai Baba Plastic Works is a small firm producing buttons. It is seeking profit maximisation. At the prevailing market price, say ₹12 per box, it can sell as many buttons as it produces. It has, however, a limited capacity of a single manufacturing plant. It is operating at full capacity on all working days, except Sundays. If it has to work on Sunday, the firm has to pay overtime (double) wage rates to the workers. As such, the marginal costs of production on weekdays remain constant, but tend to be higher on Sundays.

Suppose, the firm gets a contract from 'Big-Boss' a garment producing firm to supply the buttons with its brand-name and ready to pay ₹18 per box for weekly order of 1000 boxes. The firm's full capacity daily output is 1000 boxes, which it can sell at ₹12 per box in the market. The firm's weekly fixed costs amount to ₹1000 (rent + interest + insurance). Variable costs is ₹10 per box (raw materials ₹ 5 + labour cost ₹ 5).

Assuming no cost difference between ordinary and brand-name imposed buttons, what should be the output determination by the firm? Should the firm produce more by working on Sundays?

The rational decision can be guided by the marginal approach of profit maximisation rule suggested by the economic theory.

In this case, the marginal costs (MC) remain constant at ₹10 for the normal working days — Monday to Saturday. On Sunday, however, the MC tends to be ₹15 per box. (₹ 5 raw materials costs and ₹10



labour cost).

Day	Output (Q)	Price (P) (TVC)	Total Revenue (TR)	Total Variable Cost
Monday	1000*	18	18,000	10,000
Tuesday	1000	12	12,000	10,000
Wednesday	1000	12	12,000	10,000
Thursday	1000	12	12,000	10,000
Friday	1000	12	12,000	10,000
Saturday	1000	12	12,000	10,000
Weekly Total			78,000	60,000

The rational approach to the business lies in doing the most cost effective activity first on MC consideration of the supply side; while the most revenue enhancing output should be sold first looking to the demand side.

As such, the firm should produce brand-name buttons first to cater to the high-priced order at ₹18. Thereafter, decision should be made on whether it is worthwhile to work on Sunday to produce ordinary buttons.

In this case, the marginal revenue initially for six days tend to be higher than the marginal cost. (Monday:  $MR = ₹18 > MC = ₹10$ , other five days Tuesday through Saturday  $MR = ₹12 > MC = ₹10$ ). But, on Sunday the marginal cost (₹15) tends to be higher than the marginal revenue (₹10); therefore, on Sunday the firm should not work.

The two alternative situations in this case can be reviewed as under:

[1] The firm operates on 6 days: Monday to Saturday.

with brand-name

In this case

Total Cost = TFC+ TVC

= 1,000 + 60,000 = ₹61,000

$p = TR - TC$

$p = 78,000 - 61,000 = ₹17,000$  per week

[2] The firm operates on 7 days including Sunday

For Monday to Saturday total revenue and total cost should remain the same.

On Sunday variable cost per box is ₹15, therefore, total variable cost for 1000 boxes:

$15 \times 1000 = ₹ 15,000$  Against this, total revenue is ₹ 12,000. Hence, there is a loss by ₹ 3,000.

Alternatively speaking, profits when the firm operates for 7 days will be measured as:

$TR = ₹78,000$  (Monday to Saturday output sold) + ₹12,000 (Sunday's output-sold) = ₹ 90,000

$TVC = ₹ 60,000$  (Monday to Saturday) + ₹15,000 = ₹75,000

$TC = ₹1,000$  (TFC) + ₹75,000

= ₹76,000

$p = TR -TC$

$p = 90,000 - 76,000 = 14,000$  (TVC)

It follows that when the firm operates for 6 working days its weekly profit is ₹17,000 but it tends to be less (at ₹ 14,000) when it works on Sunday as well. The right decision, therefore, is: do not operate on Sunday. The weekly equilibrium output, therefore, will be 60,000 boxes of buttons.

## 5.2 PRICING POLICIES

The traditional economic theories of pricing, based on demand and supply are of little use to businessmen in setting prices for their goods. The traditional economists rarely considered the influence exercised by middlemen, rival producers change in Government economic policies, taxation, etc., all of which are really important in price determination.

Under marginal principle of  $MC = MR$ , price and output are determined on the basic assumption of profit maximization. Some economists – Hall and Hitch of the Oxford University - rejected the assumption of profit maximization as unrealistic and inapplicable to actual business conditions. In their empirical study of actual business behaviour, Hall and Hitch found that business firms are either ignorant of the concepts of MR and MC or they do not actually calculate MR and MC. Naturally, they do not determine price and output at the point of equality of MR and MC. Besides, business firms are afraid of charging high prices in the short period much above their average costs of production, lest their price policy, resulting in supernormal profits, attract potential competitors to enter the industry and compete away the profits in the long run. High prices and high profit margins may attract public and Government reaction and possible intervention. In other words, in real life, firms would like to avoid entry of rivals and sharing of the market and for this, they would be prepared to forgo supernormal profits in the short period. Often, firms will be interested in getting a large share of the market rather than maximum profit. Sometimes, business firms are influenced by consideration of charging the “right price” with a “just profit margin”.

### 5.2.1 Factors Influencing Price of a Product

Generally, marketers consider the following factors in setting price:

1. Target customers: Price of product depends on the capacity of buyers to buy at various prices, in other words, influence of price elasticity of demand will be examined.
2. Cost of the product: Pricing is primarily based on, how much it costs to produce and market the product, i.e., both the production and distribution cost.
3. Competition: Severe competition may indicate a lower price than when there is monopoly or little competition.
4. The law: Government authorities place numerous restrictions on pricing activities.
5. Social responsibility: Pricing affects many parties, including employees, shareholders and the public at large. These should be considered in pricing.
6. Market position of the firm: The position of the market may also influence the pricing decision of the firm. It is only why the different producers of identical products sell their products at different prices.
7. Distribution channel policy: The prices of products will also depend upon the policy regarding distribution channel. The longer the channel, the higher would be the distribution costs and consequently higher the prices.
8. Price elasticity of Demand: Price elasticity refers to consequential change in demand due to change in price of the commodity. It is the relative responsiveness to the changes in price. As there an inverse relationship between price and demand for product, the demand will increase with fall in price.
9. Economic environment: In recession, prices are reduced to a sizeable extent to maintain the level of turnover. On the other hand, prices are charged higher in boom period to cover the increasing cost of production and distribution.

### 5.2.2 General Objectives of a Pricing Policy

Each pricing decision of a firm has generally one of the following objectives:

- To achieve a given rate of return for the entire product line;
- To maintain or increase the existing market share of the firm;
- To maintain at least a particular level of price stability;
- To choose and adopt a pricing policy which fits into the market conditions faced by the different products in the product line; or
- To aim at discouraging entry of new firms into the industry.

### 5.2.3 Considerations in Formulating Pricing Policies

The following are the general considerations which must be kept in view while formulating pricing policies:

1. Objectives of the firm
2. Competitive situations
3. Promotional policy
4. Price insensibility
5. Manufactures and middlemen interests
6. Pricing reutilization
7. Influence of non-business groups

### 5.2.4 Methods of Pricing

The main pricing practices can be classified into three broad categories:

#### 1) Cost Oriented Pricing:

- a) Cost-plus or full Cost Pricing
- b) Target or Rate of Return Pricing
- c) Marginal Cost Pricing

#### 2) Competition-Oriented Pricing:

- a) Going Rate Pricing
- b) Trade Association Pricing
- c) Customary Pricing
- d) Price Leadership
- e) Sealed-bid Pricing

#### 3) Demand Oriented Pricing:

- a) Differential pricing or price discrimination
- b) Perceived Value Pricing

#### 4) Pricing Based on Other Economic Considerations:

- a) Administered Pricing
- b) Dual Pricing
- c) Shadow Pricing
- d) Multiple Product Pricing

**5) Pricing Policies Based on Market Conditions:**

- a) Perfect competition
- b) Monopoly
- c) Temporary monopoly
- d) Duopoly
- e) Oligopoly
- f) Monopolistic competition.
- g) Skimming Price Policy

**(1) Cost Oriented Price:**

**a) Cost – plus pricing:**

Business firms under oligopoly and monopolistic competitive conditions do not determine price and output by comparing marginal cost and marginal revenue but fix prices on the basis of full average cost of production which consists of direct cost or variable cost per unit plus overhead cost of fixed cost per unit plus a margin of normal profit or some satisfactory margin of profit.

In other words:

$$\text{PRICE} = \text{AVC} + \text{AFC} + \text{a profit margin}$$

Now AVC + AFC make up the average cost of production per unit of output and the profit margin added to the average cost is a certain percentage of cost. It is important to note that this profit margin is arbitrary – it may be 10% or 15% or, for that matter, any percentage of profit is known as the mark up.

This approach to price determination is known as full cost pricing or average cost pricing since the firm fixes the price of its product on the basis of covering full cost or average cost; the theory is also known as cost- plus pricing or mark-up pricing.

**b) Marginal Cost Pricing:**

Marginal cost pricing is said to be better than full cost pricing. Under full cost pricing, price is based on total costs comprising fixed and variable costs. Under marginal cost pricing, fixed costs are ignored and pricing is determined on the basis of marginal cost which refers to the cost of producing additional units. The price fixed must cover the marginal cost and total cost-which will have to be covered in the long run. Price based on marginal cost will be much more aggressive than the one based on total cost. Besides, where a firm has large unused capacity, it should explore the possibility of producing and selling more-it should cover the cost of producing the additional units (Marginal cost). The real difficulty is that the management may not always be aware of the concept of marginal cost.

**c) Rate of return (or Target) Pricing:**

It is a refined version of cost-plus pricing. When due to certain reasons, the firm has to revise its prices it needs to ensure that the prices so revised would allow it to maintain either:

- 1. A fixed percentage mark-up over cost;
- 2. Profit as a fixed percentage of total sales; or
- 3. A fixed return on existing investments.

Rate of return price is determined in the following manner:

Step 1. The firm specifies an expected rate of return on investment (expressed as earnings divided by capital invested).



Step II. To determine a 'normal rate' of output by the firm and then to estimate the 'full cost' on the basis of this normal rate of production.

Step III. To estimate 'capital turnover' ratio (expressed as invested capital divided by full cost).

Step IV. To multiply capital turnover ratio with the expected rate of return on investment (as found in Step I). This will give us the mark-up percentage.

Step V. To compute Rate of Return (ROR) price, we add up the full cost and the mark-up, i.e.,  $P = \text{Full Cost} + \text{Mark-up}$

The first four steps can be summarized in the following formula:

$$\text{Mark-up} = \frac{\text{Capital Invested}}{\text{Full Cost}} = \frac{\text{Earnings}}{\text{Capital invested}} = \frac{\text{Earnings}}{\text{Full Cost}}$$

## (2) Competition Oriented Pricing:

### a) Going Rate Pricing:

Another method of pricing adopted by small firms – which are price followers – is known as going rate pricing. Under this system, a firm sets its price according to the general pricing structure in the industry or according to the price set by the price leader. In a sense, each firm has "monopoly" power over its produce and it can, if it chooses, fix a monopoly price and face all the consequences of monopoly. In practice, however, it prefers the easier and more practical method of choosing price going in the market. It will change its price only when other firms do the same. Such a price policy is useful and safe to a firm under certain circumstances. For instance, the firm may not have an accurate idea of its costs or it may like to play safe and not provoke the larger firm to go for cut-throat competition. Besides, it is difficult for each firm to calculate the full implication of change in costs and prices and it is much better to follow the same pattern of pricing adopted by others. Even a large firm may be satisfied with going rate pricing lest a change in price by it unnecessarily disturbs the whole market. No firm would like to "spoil" the common market by reducing the price.

### b) Trade Association pricing:

To avoid uncertainties of pricing decision and the downward pressure on prices which competition exerts, firms frequently come to the express or implied agreements to maintain prices at a similar level. Though express (or, overt) agreements are generally declared as illegal, the firms can easily and safely enter into an implied (or, tacit) collusion. Individual firms, however, may frequently find it worthwhile to break out of any such agreements, but this leads to the following possible alternatives:

- i) The price-cut may spark off a price war between the firms which will go on until one or all firms give up the struggle; or
- ii) If the firm breaking out of the collusion is able to keep its rivals in the dark about the price-cut, it can gain out of the price-cut only when either the original customers of this firm are unaware or are in some way loyal to this firm. But such situations are generally rare.

### c) Customary Pricing:

There are certain goods whose prices tend to be fixed more or less in the minds of consumers-these are known as the "Charm" prices. Change in costs of production – if the change is moderate – will not affect the price, as the firms will not and cannot change the price. Accordingly, a rise in cost of production may probably lead to reduction in quality of the product but not to a rise in price. Likewise, a fall in cost of production may not be accompanied by a decline in price. Pricing in this case may be known as customary pricing.

**d) Price leadership:**

If often happens that in an industry there is one or many big firms whose cost of production is low and they dominate the industry. In such a situation, the small firms will not like to enter into price war with these big firms. The former may, therefore, follow the price fixed by the leader. For example, Cadbury may be accepted as a leader in the chocolate industry, Hindustan Lever in the soap industry, and so on. Small firms may change the price only when there is a general change in the cost of production and the price leader has recognized and adjusted his price on that basis. In fact, the price leadership pattern is adopted as a strategy of co-existence – each firm catering to its market.

It is not necessary that the price charged by small firms must equal that charged by the price-leader. There might be some difference in their prices (though it cannot be significant) but any change in the price is always in the same direction for both the price-leader and the followers, and is generally in the same proportion too. As a result, both will have their own markets to cater, thus avoiding diversion of customers.

**e) Sealed – bid pricing:**

This method is more popular in tenders and contracts. Each contracting firm quotes its price in a sealed cover called 'tender'. All the tenders are opened on a scheduled date and the person, who quotes the lowest price, other things remaining the same, is awarded the contract.

**(3) Demand Oriented Pricing:**

**a) Differential pricing or price discrimination**

There are many bases on which the open price discrimination is practiced. These are discussed below:

- Time Price Differentials: It is a general practice to use the expression “the demand for a product or service”, but it is important to note that demand also has a time dimension. The demand may shift in fairly short-time intervals. For example, demand for telephone facilities is more in the day time rather than at night.
- Use Price differentials: Different buyers have different uses of a product or a service. For example railways can be used for long-haul or short-haul freight traffic. Railways can also be used for transporting different types of commodities. Electricity can similarly, be used for industrial or residential purposes.
- Quality price Differentials: If the product caters to that group of consumers who are concerned about its quality, then the quality becomes a significant determinant of demand elasticity. The seller has, therefore, to create differences in quality to sell his product. It must be emphasized here that the differences in quality basically depend upon the buyers' understanding of the quality. Sellers use many devices to create quality differences.
- Quantity Differentials: When the seller discriminates on the basis of the quantity of purchase, it is known as quantity differentials. Quantity discounts are price concessions based on the size of the lot purchased at one time and delivered at one location. These discounts are thus related to size of a single purchase. The size of the lot purchased is measured in terms of either physical units or monetary units. Sometimes, discounts are according to the trade status, i.e., wholesaler, retailer, jobber, etc.

**b) Perceived Value Pricing:**

Perceived value pricing refers to fixing the price on the basis of a buyer's perception of the value of the product.

#### **(4) Pricing Based on Other Economic Considerations:**

##### **a) Administered Prices:**

Administered prices are the prices which are fixed and enforced by the Government. The term administered prices was introduced by Keynes.

Characteristics of administered prices:

1. They are fixed by Government
2. They are statutory i.e., legally enforced by the Government
3. They are regulatory in nature
4. They are meant as corrective measure
5. They are the outcome of the price policy of the Government.

##### **b) Dual Pricing:**

Dual pricing is a system in which there are two prices for the same commodity at the same time – one is a controlled price fixed by the Government and the other is a free market price based on conditions of demand and supply. The controlled price is fixed price while the free market price is a fluctuating price. Generally, the Government fixed the prices of a commodity – say, sugar – at a level which will cover the cost of production and permit a reasonable margin of profit. But this controlled price is obviously lower than the free market price because of the existence of excess of demand over supply. The controlled price is mainly for the benefit of lower income groups and it may often be fixed so low that the producers may incur a small margin of loss. The producers are compelled to sell part of their output at the controlled rate to the weaker sections of the community but are permitted to sell the surplus stocks in the market at the free market price which is much higher. This enables the producers to make up their loss in the controlled market or increase their volume of profit. Besides, the general consumers are given a chance to satisfy their demand fully from the market.

##### **c) Shadow Pricing:**

The producer has to decide two questions – 1) how much of each product should be produced to maximize profits? 2) What price is worth paying for additional quantities of a scarce resource? To decide the second question “What price is worth paying for additional quantity of a scarce resource”, very often “shadow prices” are used. Shadow prices are not prices obtained by observing the real world. Shadow prices are “imputed values”. The shadow price shows the marginal contribution of the factors of production employed. It is calculated by using the “simplex method”. These imputed values show the increase in profit which would result if an additional unit of that scarce factor is used. The imputed value is the reduction in contribution if that scarce factor is removed.

##### **d) Multiple Product Pricing:**

Now-a-days, multiple production is a common phenomenon. Almost all firms have more than one product in their line of production. Pricing of products under those conditions is known as multi-product pricing. The major problem in pricing of multiple products is that each product has a separate demand curve. But all of them are produced under one organisation by interchangeable production facilities, they have only one inseparable marginal cost curve. Hence marginal rule of pricing cannot be applied. E.W. Clemens suggests a solution to this problem as – third degree price discrimination under monopoly. As a discriminating monopoly tries to maximize its revenue in all its markets so does a multi-product firm in respect of each of its products.

Even the most specialized firms produce a commodity in multiple models, styles and sizes, each so much differentiated from the other that each model or size, may be considered a different product.



For example:

Refrigerators – 165 liters, 200 liters, 250 liters, single door model, two door model, bottom racks, top racks models etc.

Television sets – 14 inches, 20 inches, 21 inches, 25 inches, 27 inches, color - black & white, remote model, without – remote model, flat screen model, digital sound two speakers, four speakers, home theater systems etc.

**(5) Pricing Policies Based on Market Conditions:**

**(a) Perfect Competition:**

A firm can only sell its product at the market price and nothing above it. In the long run, for an efficient firm, the sales price is just equal to the average cost. Normal profit is made. There is no excess profit.

**(b) Monopoly:**

Monopolies are almost always nationalized enterprises for which the criterion of maximization of profit is not justifiable. In reality, a firm enjoys monopoly position only because it has succeeded in eliminating or absorbing its competitors. It is therefore probable that, initially, it was better organized and more efficient.

The technical advantages which benefit large firms in certain branches of industry can also neutralize, at least partly, the harmful effects of a monopoly. Finally, “any defacto monopoly must be prepared to defend itself, on the one hand, against the emergence of substitute competitors and, on the other, against the competition of substitute products, which imposes a limitation on its profit realization”.

In general, to prevent the entry of new firms, a monopolist must set entry-preventing prices, i.e., it should hold prices at a level which will tend to discourage new firms from entering that particular branch of industry. This presupposes an implicit estimation of production costs of possible competitors, and of the profits which will be required to attract them.

On the contrary, in order to fight the competition of substitute products, a monopoly must establish its price policy on the basis of a demand curve which will actually take those products into account. When the uses of goods produced by a monopoly are many, the degree of monopoly can vary enormously from one use to another. In case of coal, for instance, sales range from the industrial market- in which the fuel oil competition is extremely active – to blast furnace coke market – in which coal enjoys a technical monopoly.

So profit maximization demands that management collect more detailed econometric data in the environment of monopoly, than in that of perfect competition.

**(c) Temporary monopoly:**

This situation occurs more frequently. A firm invents a new product and places it on the market. For quite some time the demand will remain low, as consumers are not yet aware of the product. The firm will enjoy a de facto monopoly under the protection of its patents. Then, as the product enters into common usage, demand develops rapidly. Additional firms try to enter the market. They develop new production methods. Gradually, prices and production techniques tend to stabilize. So at the end, the market evolves towards an ordinary competitive one.

A firm which invents a new product must determine a strategy relating to prices and production which leads to a maximum effective income. Following J. Dean, we may consider two extreme cases: that of skimming of demand and that of creating a demand market.

**(d) Skimming Price Policy:**

When the product is new but with a high degree of consumer acceptability, the firm may decide to charge a high mark up and, therefore, charge a high price. The system of charging high prices

for new products is known as price skimming for the object is to “skim the cream” from the market. There are many reasons for adopting a high mark-up and, therefore, high initial price:

- i) The demand for the new product is relatively inelastic. The high prices will not stop the new consumers from demanding the product. The new product, novelty, commands a better price. Above all, in the initial stage, cross elasticity of demand is low.
- ii) If life of the product promises to be a short one, the management may fix a high price so that it can get as much profit as possible and, in as short a period as possible.
- iii) Such an initially high price is also suitable if the firm can divide the market into different segments based on different elasticities. The firm can introduce a cheaper model in the market with lower elasticity.
- iv) High initial price may also be needed in those cases where there is heavy investment of capital and when the costs of introducing a new product are high. The initial price of a transistor radio was ₹ 500 or more (now ₹ 50 or even less).

**(e) Duopoly:**

This is the case where there are only two firms in an industry. Each duopolist can choose his production in such a way as to maximize his income for a given value of output. Each duopolist has no interest in modifying his behaviour as long as the other does not modify this.

If both duopolists attempt to take one another's reactions into account, the problem is no longer predetermined. Duopoly is often characterized by instability. Duopolists eliminate their competitors through price wars or through agreements. Duopolists can assure themselves by cooperating, a total income greater than the sum of the revenues that each can insure for himself by non-cooperative behaviour.

**(f) Oligopoly:**

In oligopolistic situations, entrepreneurs attempt to avoid price wars which are ruinous for the industry. Being aware of the fact that their rivals can do the same, they refrain from seeking to increase their share of the market through price cuts. As a result, oligopoly can attain a certain stability characterized by: a) the 'price leadership' of a firm, b) the reduction of hidden prices, and c) competition in fields other than that of price (like promotion, packaging, etc.).

Now, about the lowering of hidden prices. It can assume various forms. It is contingent upon the customer, upon the size of the order, upon the geographical area and the existence of inferior brands. This policy has the advantage that it precedes adjustments of official prices and in this way contributes to the stability of oligopolists.

Finally, non-price competition is a substitute for price competition. It is much less dangerous because its effects are felt in the long run. So the possibilities of reactions from competition are more limited.

**(g) Monopolistic competition:**

In this type of market, price policies are extremely varied because of product differentiation. Each firm is faced with a separate demand curve and a market price.

### 5.2.5 Pricing of a New Product

Basically, the pricing policy of a new product is the same as that for an established product – viz., the price must cover the full costs in the long run and direct costs or prime costs in the short period.

**1. Introduction Stage:**

There are two alternative price strategies which a firm introducing a new product can adopt, viz., skimming price policy and penetration pricing policy.

**a) Skimming Price Policy:**

As discussed earlier, it is a strategy of pricing in which a marketer, at first, sets a relatively high price for a product or service, then lowers the price over time. As the demand of the first customers is satisfied, the firm lowers the price to attract another, more price-sensitive segment.

**b) Penetration Price Policy:**

Instead of setting a high price, the firm may set a low price for a new product by adding a low mark-up to the full cost. This is done to penetrate the market as quickly as possible. The assumptions behind the low penetration price policy are:

- i) The new product is being introduced in a market which is already served by well-known brands. A low price is necessary to attract consumers who are already accustomed to other brands.
- ii) The low price will help to maximize the sales of the product even in the short period.
- iii) The low price is set in the market to prevent the entry of new products.

Penetration price policy is preferred to skimming price under three conditions:

In the first place, skimming price offering a high margin will attract many rivals to enter the market. With the entry of powerful rivals into the market, competition will be intensified, price will fall and profits will be competed away in the long run. A firm will prefer a low penetration price if it fears the entry of powerful rivals with plenty of capital and new technology. A low penetration price, based on extremely low mark-up will be least profitable and potential competitors will not be induced to enter the market.

Secondly, a firm will prefer low penetration price strategy if product differentiation is low and if rival firms can easily imitate the product. In such a case, the objective of the firm to fix low price is to establish a strong market base and build goodwill among consumers and strong consumer loyalty.

Finally, a firm may anticipate that its main product may generate continuing demand for the complementary items. In such a case, the firm will follow penetration pricing for its new product, so that the product as well as its complements will get a wider market.

**2. Pricing during Product Maturity stage:**

When the product reaches maturity period the firm finds that

- a) Many rivals have already entered the market.
- b) Competition is intense; and
- c) Demand for the product has become more elastic.

Under these conditions, the firm may have to reduce its mark-up and, therefore, the price. In other words, the price of a product in the maturity period will be equal to full cost plus low mark-up.

**3. Pricing during Product Decline stage:**

In the third stage of the life cycle, the product ultimately becomes a common product. In this period, the competition in the market is severe and the demand for the product is highly elastic. In order to remain in the market, the firm has to charge only a normal mark-up with the full cost.

**5.2.6 The Role of Demand in Pricing Decisions**

How a business firm's buyers respond to a change in price is an important consideration, for the eventual effect on sales volume and revenue is determined by the degree of buyer's demand sensitivity to price

changes. However, price –setters of ten miss the following four points:

**1. Market Vs Firm Elasticity:**

Price elasticity of demand is a measure of the degree to which buyers are sensitive to price changes. In any market characterized by several functionally substitutable products, there are actually two demand schedules: 1) demand for the general product (primary demand) and 2) demand for the firm's specific offering (secondary demand). In general, secondary demand is found to be more price elastic. But a seller may sometimes mistake relatively inelastic market or primary demand as elastic secondary demand.

**2. Demand for buyer's Output:**

The Market for buyer's products may actually be price-elastic. So a reduction in price by a firm would raise demand for its product. Hence, manufacturers selling to such buyers, and whose product represents a significant portion of these buyers product costs may curtail sales opportunities by eliminating discounts or low margin products.

**3. Likelihood of Competitive Entry:**

K.B. Monroe has pointed out that "an emphasis on high-price strategies may encourage the entry of competitors when entry barriers are minor and when demand is actually price-elastic. Moreover, high prices or rapidly increasing prices may force buyers to reconsider their need and, perhaps, actively seek out competitive substitutes.

**4. Demand Consequences of a Product Line:**

Most firms sell a wide variety of products requiring a variety of different marketing strategies. Within a product line there are usually some products that are functional substitutes for each other and some products that are functionally complementary. For example, a photographic product line includes such items like cameras, films, flash bulbs, projectors, screens and other accessories. Because of the demand interrelationships and because there are usually several price-market targets, the product line pricing problem throws a major challenge before the marketing executives.

**5.2.7 The Role of Costs in Pricing Decisions**

Costs play an important role in pricing. Given the selling objectives of a firm, the demand variable provides an upper limit on the pricing discretion the firm enjoys. This limit is the willingness of buyers to purchase a commodity at a stated price. On the contrary, the other variable affecting profits is cost, which sets a floor to a firm's pricing discretion. If prices are too low in comparison with costs, volume may be high but profit will be almost nil.

In the words of Monroe, "objective cost data are essential for deciding what price to set. Only by determining the difference between costs and price under consideration, and then balancing that margin against the capacity necessary to produce the estimated volume, can the seller determine the value of the product in terms of its contribution to recovering the seller's initial investment". True, the cost aspect of a pricing decision is mainly concerned with ascertaining what costs are relevant to the decision. When cost-plus methods of pricing are used, and the cost portion of the formula is arbitrarily determined, the resultant price is erroneous in that the pricing formula does not allow for demand or for competition.

It is important for the seller to know the determinants and behaviour of product costs for four major reasons:

1. In order to know when to accelerate cost recovery;
2. In order to know how to evaluate a change in selling price;
3. In order to take decision on how to profitably segment a market; and

4. In order to take decision on when to add products or to eliminate products from the product line. Even so, costs play a limited role in pricing. It is because they indicate “whether the product can be made and sold profitably at any price, but they do not indicate the amount of mark-up or mark-down on cost buyers will accept. Proper costs serve to guide management in the selection of a profitable product mix and to determine how much cost can be incurred without sacrificing profit”.

Costs for pricing must deal with the future. Product costs must be based on expected purchase costs of raw materials, wage rates and other expenses to be incurred. In addition, information about development, promotion, and distribution costs is needed. Information on product costs should be regularly gathered to determine whether changes have occurred that may affect the relative profitability of the company. It is planned costs that are relevant, not past costs, since profit planning necessarily deals with the future.

### 5.2.8 Price Forecasting

All the methods used for demand forecasting may also be used for forecasting the market price that will exist in the next (or some future) period. We would use some kind of a qualitative forecast. or, we might use a time-series in which price follows a trend.

However, in practice, we normally use an econometric model to obtain market price forecasts. This requires that we specify and estimate both the market demand and market supply functions.

After estimating these functions, we must obtain the forecasted values for the exogenous variables (e.g., income and prices of inputs.) Inserting those forecasts into our estimated demand and supply functions, we can solve the equations to obtain the price forecast.

### Mini Case: Pricing Policies: New Strategies

In these days of intense competitive business situation, firms in general are more concerned with the approximate pricing policies for their products. Especially, in retail business in modern times, new strategies like ‘every day low pricing’ “yield management” and ‘price matching’ have evolved in practice.

- Everyday low pricing:

In the American markets, retailers such as Montgomery Ward, Sears and Wal-Mart to mention a few among others, have introduced the strategy of ‘Everyday Low Pricing’. Similarly, TESCO in Thailand and Malaysia tends to follow this kind of strategy.

Reduction in advertising expenses is assumed to be the major gain of this pricing strategy. In the retail business of general merchandise, the firm such as Wal-Mart Stores has succeeded very well in everyday low pricing strategy on account of its customer focus as well as highly efficient distribution system and cost controlling measure in shipping and inventories.

- Yield management:

Under the ‘yield management’ strategy the firm charges the price in accordance with the demand fluctuations in the market. When demand is seen to be increasing, the price is raised. When the demand slacks, the price is quickly lowered to arrest the declining business yield. For this, the firm has to keep a continuous track on market situation: demand trend and the sales trends. Hotels and Airlines usually follow this strategy by keeping a track record of consumer demand, its segmentations over a period of time. A market demand differential is seen among the tourists and executive customers of hotels and airlines.

- Price matching:

Firms may set offer prices occasionally to match with competitive market prices. In practice, however, it is observed that few buyers take the advantage of such offers. Those who do not take advantage belong to a segment of the market with greater willingness to pay more; eventually, they pay up high prices.



## TECHNIQUES AND APPLICATIONS OF ECONOMICS

In all this, we have discussed demand, elasticity of demand, price determination under various markets etc. Further we have also discussed total cost, average cost, marginal cost, marginal revenue etc. Profit maximization, revenue maximization and cost minimization can be made using the following economic techniques, which are useful in taking several managerial decisions.

Problems are worked out and given as illustrations in the following pages relating to all the above concepts for better understanding. Before those illustrations are worked out, the following terminology should be understood by anybody to go further.

- 1) Total Cost (TC) = Fixed Cost (FC) + Variable Cost (VC)

Variable Cost is directly proportional to the number of units produced.

$$\therefore \text{Total Cost} = F + kx = C \text{ (Say)}$$

Where F is the fixed cost and k the constant of proportionality

Total Cost (c) is expressed as a function of output (x) produced i.e.  $c = f(x)$  or  $c = f(q)$  or  $f(u)$ .

$$\text{Total cost (c)} = f(x) + k$$

- 2) Average Cost (AC) =  $\frac{\text{Total Cost}}{\text{Total number of units produced (Quantity)}} = \frac{c}{x} = \frac{f(x) + k}{x}$

Average Variable Cost (AVC) =  $\frac{f(x)}{x}$  as 'k' is fixed cost.

$$\text{Average fixed cost (AVC)} = \frac{k}{x}$$

- 3) Marginal Cost (MC) = Differential Coefficient of total cost w.r.t quantity  
 $= \frac{dc}{dx}$

Marginal cost =  $\frac{dc}{dx} = f'(x)$  because k's derivative is 0

### CASE:

(i) When average cost goes upward,  $\frac{d}{dx} \cdot \frac{c}{x} \geq 0$  i.e.  $MC > AC$ .

(ii) When the average cost curve reaches a minimum point i.e. constant  $\frac{d}{dx} \cdot \frac{c}{x} = 0$   
i.e.  $MC = AC$ .

(iii) When AC is falling downwards  $\frac{d}{dx} \cdot \frac{c}{x} \leq 0$  i.e.  $MC < AC$ .

\*\* Prove That The Slope Of Average Cost Curve Is  $\frac{1}{x} (MC - AC)$

### PROOF:

Let cost be 'C' and units be 'x'.

Then Average cost (say, y) =  $\frac{C}{x}$

To find out the slope, the average cost should be differentiated w.r.t. 'x'.

$$\begin{aligned} \frac{dy}{dx} &= \frac{x \cdot \frac{dy}{dx} - c \cdot 1}{x^2} \\ &= \frac{x \cdot \frac{dy}{dx} - c}{x^2} \\ &= \frac{dc}{x \cdot dx} - \frac{c}{x^2} \end{aligned}$$

$$= \frac{1}{x} c \frac{dc}{dx} - \frac{c}{x} \pi$$

$$= \frac{1}{x} (MC - AC) \quad (\text{proved})$$

4) Total Revenue (TR) = Quantity sold × selling price per unit of the commodity  
 $R = px$  where  $p$  is the price per unit and  $x$  the number of units sold.

5) Average Revenue (AR) =  $\frac{\text{Total Revenue}}{\text{Quantity Sold}}$

6) Marginal Revenue (MR) = Differential Coefficient of total Revenue w.r.t quantity =  $\frac{dR}{dx}$

7) Profit (P) = Total Revenue (TR) – Total cost (TC)

8) For maximum Profit: Marginal Revenue (MR) = Marginal Cost (MC)

$$\text{Profit} = R - C$$

Marginal profit is the first derivative of profit function.

i.e. where  $p$  = profit and  $x$  = quantity and marginal profit =  $\frac{dR}{dx}$

9) Price Elasticity of Demand.

Price Elasticity of demand is the degree of responsiveness of the demand for a commodity to a change in its price.

$$\text{Price elasticity of demand} = \frac{\frac{\text{Change in quantity demanded}}{\text{Quantity demanded at original price}}}{\frac{\text{Change in price}}{\text{Original price}}} = \frac{\frac{dx}{x}}{\frac{dp}{p}} = \frac{dx}{x} \div \frac{dp}{p} = 1$$

Where  $x$  is the quantity demanded at original price and  $p$  is the original price per unit.

It may further be noted that if the price increases, quantity demanded will decrease i.e., Corresponding to any change in price, quantity demanded changes in the opposite direction i.e.,  $\frac{dx}{dp}$  is always negative. But we take only numerical value and hence ignore the sign.

Price elasticity of demand is denoted by  $E_p = -\frac{dp}{p} \div \frac{dx}{x} = \frac{dx}{x} \div \frac{dp}{p}$  (numerically)

**\*\* Show that elasticity of demand =  $\frac{AR}{AR - MR}$ , where AR and MR are average and marginal revenue respectively at any output.**

**Proof:**

$$\text{Total Revenue, (say } R) = px, AR = \frac{R}{x} = \frac{px}{x} = p$$

$$MR = \frac{d}{dx} (R) = \frac{d}{dx} (px) = p + x \frac{dp}{dx}$$

$$\text{Now, } \frac{AR}{AR - MR} = \frac{p}{p - p - x \frac{dp}{dx}} = \frac{p}{-x \frac{dp}{dx}} = -\frac{p \frac{dp}{dx}}{x \frac{dp}{dx}} = -\frac{dp}{x} \times \frac{p}{p} = |E_p| \text{ (proved)}$$

10) If marginal revenue function is given, total revenue function can be found out in the following manner.

$$\text{We have } MR = \frac{dR}{dx}$$

$$\Rightarrow MR = \frac{dR}{dx}$$

$$\Rightarrow MR dx = dR$$

Integrating with respect to x

$$\int dR = \int MR dx$$

$$\Rightarrow R = \int MR dx + k, \quad \text{where } r = 2x$$

To find out total cost, when marginal cost is given

$$MC = \frac{dR}{dx}$$

$$\Rightarrow dc = MC dx$$

Integrating with respect to x

$$\int dc = \int MC dx$$

$$\Rightarrow c = \int MC dx + k$$

### 11) Consumer's surplus

Let y = price; f(x) = demand

$$\text{i.e. } y = f(x)$$

where  $x_0, p_0$  refers to actuals.

$$\therefore \text{Consumer's surplus} = \int_0^{x_0} f(x) dx - x_0 p_0$$

### 12) Producer's surplus

$$\text{Producer's surplus} = x_0 p_0 - \int_0^{x_0} f(x) dx$$

### 13) Cross demand

If  $x_1 = p_1$ ;  $x_2 = p_2$  be the two demand functions of the commodities A & B, then the following results would emerge.

(i) If  $\frac{\partial x_1}{\partial p_2}$  and  $\frac{\partial x_2}{\partial p_1}$  are  $< 0$ , then the commodities are complementary

(ii) If  $\frac{\partial x_1}{\partial p_2}$  and  $\frac{\partial x_2}{\partial p_1}$  are  $> 0$ , then the commodities are said to be substitutes or competitive.

(iii) If  $\frac{\partial x_1}{\partial p_2} > 0$  (or)  $< 0$  and  $\frac{\partial x_2}{\partial p_1} < 0$  or  $> 0$ , they are said to be unrelated that means no relationship can be established.

### Illustration: 1

The cost (c) of a firm is given by the function  $c = 4x^3 + 9x^2 + 11x + 27$ . Find the Average Cost, Marginal Cost, Average Variable Cost, and Average Fixed Cost 'x' being the output.

#### Solution:

$$C = \text{Total Cost} = 4x^3 + 9x^2 + 11x + 27$$

$$\text{Average Cost} = 4x^2 + 9x + 11 + \frac{27}{x}$$

$$\text{Marginal Cost} = \frac{dc}{dx} = 12x^2 + 18x + 11$$

$$\text{Average Variable Cost} = 4x^2 + 9x + 11$$

$$\text{Average fixed Cost} = \frac{27}{x}$$



**Illustration: 2**

The Average Cost of a firm is given by the function Average Cost =  $x^3 + 12x^2 - 11x$ , find the Total Cost, Average Variable Cost & Marginal cost.

**Solution:**

$$\text{Average Cost} = x^3 + 12x^2 - 11x$$

$$\text{Total Cost} = x^4 + 12x^3 - 11x^2$$

$$\text{Marginal Cost} = 4x^3 + 36x^2 - 22x$$

**Illustration: 3**

The cost function of a firm is given by  $c = x^3 - 4x^2 + 7x$ , find at what level of output Average Cost is minimum and what level will it be.

**Solution:**

$$\text{Total Cost} = x^3 - 4x^2 + 7x$$

$$\text{Average Cost} = x^2 - 4x + 7$$

In order that average cost is minimum  $\frac{dy}{dx} = 0$  and the value of  $\frac{dy^2}{dx^2}$

$$\begin{aligned} \text{i.e. } \frac{dy}{dx} &= 2x - 4 = 0 \\ &= x - 2 = 0 \\ \therefore x &= 2 \end{aligned}$$

$\frac{dy^2}{dx^2} = 2$  which is positive so the function will have minimum values.

Minimum:

$$\begin{aligned} \text{Average Cost} &= x^2 - 4x + 7 \\ &= 4 - (4 \times 2) + 7 \\ &= 11 - 8 = 3 \end{aligned}$$

**Illustration: 4**

The Average Cost function (AC) for a certain commodity is given by  $AC = 2x - 1 + \frac{50}{x}$  in terms of output  $x$ , find the output for which (i) Average cost is increasing (ii) Average cost is decreasing (iii) Find the total cost (iv) Marginal Cost.

**Solution:**

In order to a function is said to be increasing (or) decreasing its derivation must be zero.

$$\frac{dy}{dx} = 2 - 50x^{-2} = 0$$

$$\Rightarrow 2 - \frac{50}{x^2} = 0$$

$$\Rightarrow 2x^2 - 50 = 0$$

$$\Rightarrow x^2 - 25 = 0$$

$$\therefore x = \pm 5$$

When  $x > 5$  it is increasing

When  $x < 5$  it is decreasing



$$\text{Total Cost} = (2x - 1 + \frac{50}{x})x = 2x^2 - x + 50$$

$$\text{Marginal Cost} = \frac{dy}{dx}(2x^2 - x + 50) = 4x - 1$$

**Illustration: 5**

The Cost function of a particular firm  $c = \frac{1}{3}x^3 - 5x^2 + 75x + 10$ , find at which level, i) The Marginal Cost attains its minimum ii) What is the marginal cost of this level?

**Solution:**

$$c = \frac{1}{3}x^3 - 5x^2 + 75x + 10$$

$$\text{Marginal Cost} = \frac{dy}{dx}$$

$$= \frac{1}{3}(3x^2) - 5(2x) + 75$$

$$= x^2 - 10x + 75 \text{ (y say)}$$

In order that the MC to be at minimum its 2<sup>nd</sup> derivative value must be positive

$$\frac{dy}{dx} = 2x - 10 = 0$$

$$\text{or } 2x = 10$$

$$x = 5$$

$$\frac{d^2y}{dx^2} = 2, \text{ which is positive when } x = 5 \text{ MC is minimum}$$

$$\begin{aligned} \therefore \text{Minimum Marginal Cost} &= 5^2 - 10 \times 5 + 75 \\ &= 25 - 50 + 75 = 50 \end{aligned}$$

**Illustration: 6**

The cost function 'c' for the commodity 'q' is given by  $C = q^3 - 4q^2 + 6q$ . Find Average Variable Cost and also find the value of q for which average variable cost is minimum.

**Solution:**

$$C = q^3 - 4q^2 + 6q$$

$$\text{Average Variable Cost} = q^2 - 4q + 6 \text{ ('y' say)}$$

$$\Rightarrow \frac{d}{dq}(q^2 - 4q + 6) = 0$$

$$\Rightarrow 2q - 4 = 0$$

$$\therefore q = \frac{4}{2} = 2$$

$$\frac{d^2y}{dq^2} = 2 > 0, \text{ positive}$$

$$\therefore \text{Average Cost is minimum at } q = 2$$

**Illustration: 7**

The cost function 'c' of a firm  $= \frac{1}{3}x^3 - x^2 + 5x + 3$ , find the level at which the marginal cost and the average variable cost attain their respective minimum.

**Solution:**

$$C = \frac{1}{3}x^3 - x^2 + 5x + 3$$

$$\text{Marginal Cost} = \frac{dC}{dx} = \frac{1}{3} 3x^2 - 2x + 5$$

$$= x^2 - 2x + 5 \text{ ('y' say)}$$

$$\frac{dy}{dx} = 2x - 2 = 0$$

$$\therefore x = 1$$

$$\frac{d^2y}{dx^2} = 2, \text{ which is positive}$$

$\therefore$  Marginal cost is minimum at  $x = 1$

$$\text{Average Variable Cost} = \frac{1}{3}x^2 - x + 5 \text{ (y say)}$$

$$\frac{d}{dx} \{\text{Average Variable Cost}\} = \frac{1}{3} 2x - 1 = 0$$

$$\Rightarrow \frac{2}{3} x = 1$$

$$\therefore x = \frac{3}{2}$$

$$\frac{d^2y}{dx^2} = \frac{2}{3}, \text{ positive}$$

$\therefore$  Average Variable Cost is minimum at output  $x = \frac{3}{2}$

**Illustration: 8**

$$\text{Cost} = 300x - 10x^2 + \frac{1}{3}x^3, \text{ Calculate}$$

- i) Output at which Marginal Cost is minimum
- ii) Output at which Average Cost is minimum
- iii) Output at which Marginal Cost = Average Cost.

**Solution:**

$$\text{i) Marginal Cost} = \frac{dC}{dx} = 300 - 20x + x^2 \text{ (say, y)}$$

In order that MC is minimum first derivate must be equal to zero and 2<sup>nd</sup> derivate must be positive.

$$\therefore \frac{dy}{dx} = 2x - 20 \Rightarrow 2x = 20$$

$$x = 10$$

$$\frac{dy^2}{dx^2} = 2, \text{ which is positive. It is minimum at } x = 10.$$

$$\text{ii) Average Cost} = 300 - 10x + \frac{1}{3} x^2 \text{ (y say)}$$

$$\frac{dy}{dx} = -10 + \frac{2}{3}x = 0$$

$$\Rightarrow x = 30/2 = 15$$

$$\frac{d^2y}{dx^2} = \frac{2}{3} > 0,$$

$\therefore$  Average Cost is minimum at  $x = 15$



iii) Output at which Marginal Cost = Average Cost

$$-20x + 10x + x^2 - \frac{1}{3}x^2 = 0$$

$$-10x + \frac{2}{3}x^2 = 0$$

$$\frac{-30x + 2x^2}{3} = 0$$

$$2x^2 - 30x = 0$$

$$2x(x - 15) = 0$$

$$x - 15 = 0$$

$$\therefore x = 15$$

**Illustration: 9**

Cost Function  $C = \frac{3}{5}x + \frac{15}{4}$ , find

- Cost when output is 5 units
- Average Cost of 10 units
- Marginal cost.

**Solution:**

$$C = \frac{3}{5}x + \frac{15}{4}$$

i) Cost when output is 5 units

$$= \frac{3}{5} \times 5 + \frac{15}{4} = 3 + \frac{15}{4} = 6.75$$

ii) Average Cost of 10 units

$$\begin{aligned} \text{Average Cost} &= \frac{3}{5} + \frac{15}{4x} \\ &= \frac{3}{5} + \frac{15}{10 \times 4} = \frac{3}{5} + \frac{15}{40} \\ &= \frac{3}{5} + \frac{3}{8} = \frac{24+15}{40} = \frac{39}{40} = 0.975 \end{aligned}$$

iii) Marginal Cost =  $\frac{dc}{dx}$

$$= \frac{3}{5} = 0.6$$

**Illustration: 10**

The Revenue function of a firm given by  $R = (2200 - 3x)\frac{x}{2}$ , find the firm's marginal revenue function.

**Solution:**

$$R = (2,200 - 3x)\frac{x}{2} = \frac{2,200x}{2} - \frac{3}{2}x^2$$

$$MR = \frac{dc}{dx} = \frac{2,200x}{2} - \frac{3}{2} \times 2x = \frac{2,200x}{2} - 3x = 1,100 - 3x$$

**Illustration: 11**

Given  $C = x^3 - 10x^2 + 9x$ ;  $R = 12x^2 + 11x - 4$ . Find the total profit and hence marginal profits.

**Solution:**

$$C = x^3 - 10x^2 + 9x$$

$$R = 12x^2 + 11x - 4$$

$$\text{Total Profit} = R - C = 12x^2 + 11x - 4 - x^3 + 10x^2 - 9x$$

$$= -x^3 + 22x^2 + 2x - 4$$

$$= -(x^3 - 22x^2 - 2x + 4) \text{ (Say P)}$$

$$\text{Marginal Profit } \frac{dP}{dx} = (3x^2 - 44x - 2)$$

**Illustration: 12**

A manufacturer can sell "x" items ( $x \geq 0$ ) at a price of  $(330 - x)$  each; the cost of producing 'x' items is ₹  $x^2 + 10x + 12$ . How many items should he sell to make the maximum profit? Also determine the maximum profit.

**Solution:**

Given price (P) =  $330 - x$

Cost (C) =  $x^2 + 10x + 12$

Output =  $x \geq 0$

Revenue (R) =  $P_x = 330x - x^2$

$$\begin{aligned} \text{Profit} = R - C &= 330x - x^2 - x^2 - 10x - 12 \\ &= 320x - 2x^2 - 12 \text{ (say } y) \end{aligned}$$

In order that maximum profit is attained

$$\frac{dy}{dx} = 0, \text{ and}$$

$$\frac{d^2y}{dx^2} = \text{Negative}$$

$$\frac{dy}{dx} = 320 - 4x = 0$$

$$\Rightarrow -4x = -320$$

$$x = 80$$

$$\frac{d^2y}{dx^2} = -4, \text{ which is negative.}$$

Therefore profit is maximum at  $x = 80$  units

$$\begin{aligned} \text{Maximum profit} &= 320(80) - 2(80)^2 - 12 \\ &= 12,788 \end{aligned}$$

**Illustration: 13**

The efficiency (E) of a small manufacturing concern depends on the number of workers (W) and is given by  $10E = \frac{-W^3}{40} + 30W - 392$ , find the strength of the worker, which give maximum efficiency.

**Solution:**

$$\text{Given } 10E = \frac{-W^3}{40} + 30W - 392$$

$$\text{Efficiency (E)} = \frac{-W^3}{400} + 3W - \frac{392}{10}$$

$$\frac{de}{dw} = -\frac{1}{400} \times 3W^2 + 3 = 0$$

$$\Rightarrow 3W^2 = 1200$$

$$\Rightarrow W^2 = 400$$

$$\Rightarrow W = 20$$

$$\frac{d^2e}{dw^2} = \frac{-6w}{400}$$

$$\therefore \frac{d^2e}{dw^2} \text{ at } w = 20 = \frac{-6(20)}{400} = \frac{-6}{20} < 0$$

$\therefore$  Maximum efficiency at  $w = 20$ .

**Illustration: 14**

A firm assumes a cost function  $c(x) = x \left( \frac{x^2}{10} + 200 \right)$ ,  $x$  is a monthly output in thousands of units. Its revenue function is given by  $R(x) = \left( \frac{2200 - 3x}{2} \right)x$ . Find i) If the firm decides to produce 10,000 units per month, the firm's cost and Marginal cost. ii) If the firm decides to incur Marginal cost of 320, the level of output per month, and cost of the firm. iii) The marginal revenue function. iv) If a decision is taken to produce 10,000 units each month, the total revenue and marginal revenue of the firm. v) If the firm generates marginal revenue of 1040, the firm's monthly output and monthly revenue. vi) The firm's profit function and marginal profit function. vii) The output required per month to make the marginal profit = 0, and find the profit at this level of output. viii) Find the marginal revenue and the marginal cost at the output obtained in (vii) above comment upon the result.

**Solution:**

$$C = x \left( \frac{x^2}{10} + 200 \right) = \frac{x^3}{10} + 200x$$

$X =$  '000 units p.m.

$$R = \left( \frac{2200 - 3x}{2} \right)x = \frac{2200x - 3x^2}{2}$$

i) if firm's output – 10,000 units per month.

$$\text{Cost} = 10 \left( \frac{100}{10} + 200 \right) = 2,100$$

$$MC = \frac{dc}{dx} = \frac{3x^2}{10} + 200$$

$$\text{Marginal Cost (at } x = 10) = \frac{3(100)}{10} + 200 = 230$$

ii) i.e.,  $MC = 320$

$$\frac{3x^2}{10} + 200 = 320$$

$$3x^2 + 2000 = 3,200$$

$$3x^2 = 1200$$

$$x^2 = 400$$

$$\therefore x = \sqrt{400} = 20$$

$$\therefore \text{Total cost} = \frac{20 \cdot 20 \cdot 20}{10} + 200 \times 20 = 4,800$$

iii) Marginal Revenue

$$= MR = \frac{dr}{dx} = \frac{2200}{2} - \frac{6x}{2}$$

$$= 1100 - 3x$$

iv) Total revenue at  $x = 10$

$$\text{is } \frac{2200 \times 10 - 3(100)}{2} = \frac{22000 - 300}{2} = \frac{21700}{2}$$

$$= 10850$$

$$\text{Marginal Revenue} = 1100 - 3 \times 10 = 1070$$

v) Given,  $MR = 1040$

$$\text{i.e. } 1100 - 3x = 1040$$

$$-3x = -60$$

$$x = 20$$

$$\text{Monthly Revenue} = \frac{2200 \times 20}{2} - \frac{3 \times 400}{2}$$

$$= 22000 - 600 = 21400$$

$$\text{vi) Profit} = R - C = \frac{2200x}{2} - \frac{3x^2}{2} - \frac{x^3}{10} - 200x$$

$$= \frac{-x^3}{10} - \frac{3x^2}{2} + 900x \text{ (say } p)$$

$$\text{Marginal Profit} = \frac{dp}{dx} = \frac{-3x^2}{10} - \frac{6x}{2} + 900$$

vii)  $MP = 0$  (given)

$$\frac{-3x^2}{10} - 3x + 900 = 0$$

$$\Rightarrow -3x^2 - 30x + 9000 = 0$$

$$x^2 + 10x - 3000 = 0$$

$$x^2 + 60x - 50x - 3000 = 0$$

$$x(x + 60) - 50(x + 60) = 0$$

$$x(x - 50)(x + 60) = 0$$

$$\therefore x = 50 \text{ or } x = -60$$

$$\text{Profit} = R - C = \frac{2200x}{2} - \frac{3x^2}{2} - \frac{x^3}{10} - 200x$$

$$\text{Profit, at output } x = 50$$

$$= 28750$$

viii) Marginal cost at  $x = 50$

$$= \frac{3x^2}{10} + 200 = \frac{3(2500)}{10} + 200 = 950$$

$$\text{Marginal Revenue} = \text{at } x = 50$$

$$1100 - 3x = 1100 - 3 \times 50 = 950$$

Profit will be maximum at  $MC = MR$

**Illustration: 15**

A radio manufacturer produces 'x' sets per week at total cost of ₹  $x^2 + 78x + 2500$ . He is a monopolist and the demand function for his product is  $x = \frac{(600 - P)}{8}$ , when the price is 'p' per set. Show that maximum net revenue is obtained when 29 sets are produced per week. What is the monopoly price?

**Solution:**

$$\text{Cost (C)} = x^2 + 78x + 2500$$

$$\text{Demand (D)} X = (600 - P) / 8$$

$$8x = 600 - P$$

$$\therefore P = 600 - 8x$$

Total Revenue for 'x' sets

$$\text{Price} \times \text{Quantity i.e., } 600x - 8x^2$$

Maximum revenue is obtained at  $MC = MR$

$$\text{Marginal Cost} = \frac{dc}{dx} = 2x + 78 - \text{(i)}$$

$$\text{Marginal Revenue} = \frac{dr}{dx} = 600 - 16x - \text{(ii)}$$

Equity (i) & (ii)

$$2x + 78 = 600 - 16x$$

$$= 18x = 522$$

$$\therefore x = \frac{522}{18} = 29$$

Monopoly price  $600 - 8x$

$$600 - 8 \times 29$$

$$= 600 - 232 = 368$$

**Illustration: 16**

The demand function for a particular commodity is  $y = 15 e^{-\frac{x}{5}}$ , where 'y' is the price per unit and 'x' is the no. of units demanded, determine the price and quantity for which revenue is maximum.

**Solution:**

$$\text{Demand function } y = 15 e^{-\frac{x}{5}}$$

$$\text{Total Revenue (R)} = 15 \times e^{-\frac{x}{5}}$$

$$\text{In order that Revenue is maximum } \frac{dR}{dx} = 0$$

$$\text{And } \frac{d^2R}{dx^2} = \text{negative}$$

$$\frac{dR}{dx} = 15 \left( e^{-\frac{x}{5}} - \frac{1}{5} \times e^{-\frac{x}{5}} \times 1 \right)$$

$$= 15 \left( e^{-\frac{x}{5}} - \frac{x e^{-\frac{x}{5}}}{5} \right)$$

$$= 15 e^{-\frac{x}{5}} \left( 1 - \frac{x}{5} \right) = 0$$



$$\text{i.e., } 1 - \frac{x}{5} = 0$$

$$\therefore x = 5$$

$$\begin{aligned} \frac{d^2R}{dx^2} &= 15 \left[ \frac{x}{25} e^{-x/5} - \frac{e^{-x/5}}{5} - \frac{e^{-x/5}}{5} \right] \\ &= 15 \left[ \frac{x}{25} e^{-x/5} - \frac{2e^{-x/5}}{5} \right] \end{aligned}$$

$$\therefore \frac{d^2R}{dx^2} \text{ at } x = 5 = 15 \left[ \frac{1}{5e} - \frac{2}{5e} \right] = -ve$$

**Illustration: 17**

$P = \frac{150}{q^2 + 2} - 4$  represents the demand function for a product where 'p' is the price per unit for 'q' units; determine the marginal revenue function.

**Solution:**

$$P = \frac{150}{q^2 + 2} - 4$$

$$\text{Revenue (R)} = \frac{150q}{q^2 + 2} - 4q$$

$$\begin{aligned} \text{M.R} &= \frac{dR}{dq} = \frac{150q^2 + 2(150) - 150q \times 2q}{(q^2 + 2)^2} - 4 \\ &= \frac{150q^2 + 300 - 300q^2}{(q^2 + 2)^2} - 4 \end{aligned}$$

**Illustration: 18**

A manufacturer can sell 'x' items per month, at price  $P = 300 - 2x$ . Manufacturer's cost of production ₹ Y of 'x' items is given by  $Y = 2x + 1000$ . Find no. of items to be produced to yield maximum profit p.m.

**Solution:**

$$\text{Units} = x$$

$$\text{Price} = 300 - 2x$$

$$\text{Revenue (R)} = Px = 300x - 2x^2$$

$$\text{Cost (C)} = 2x + 1000$$

$$\text{Profit (z)} = 300x - 2x^2 - 2x - 1000$$

$$= -2x^2 + 298x - 1000 \text{ (Say 'z')}$$

$$\frac{dz}{dx} = -4x + 298 = 0$$

$$-4x = -298$$

$$x = \frac{298}{4} = 74.5$$

$$\frac{d^2z}{dx^2} = -4 \text{ which is negative}$$

$$\frac{d^2z}{dx^2} < 0$$

$\therefore$  Profit is maximum at  $x = 74.5$  units

**Illustration: 19**

The price (P) per unit at which company can sell all that it produces is given by the function  $P(x) = 300 - 4x$ . The cost function is  $500 + 28x$ , where 'x' is the number of units, find x, so that profit is maximum.

**Solution:**

$$P = 300 - 4x$$

$$R = P(x) = 300x - 4x^2$$

$$C = 500 + 28x$$

$$P = R - C$$

$$\text{Profit} = 300x - 4x^2 - 500 - 28x$$

$$= -4x^2 + 272x - 500 \text{ (Say 'z')}$$

$$\frac{dz}{dx} = -8x + 272 = 0$$

$$-8x = -272$$

$$X = \frac{272}{8} = 34$$

$$\frac{d^2z}{dx^2} = -8, \text{ which is Negative}$$

Profit is maximum at  $x = 34$  units.

**Illustration: 20**

If 'n' be the no. of workers employed the average cost of production is given by

$$C = 24n + \left[ \frac{3}{2(n-4)} \right] \text{ Show that } n = 4\frac{1}{4} \text{ will make } C \text{ minimum.}$$

**Solution:**

$$C = 24n + \left[ \frac{3}{2(n-4)} \right] = 24n + \frac{3}{2}(n-4)^{-1}$$

$$\frac{dc}{dn} = 24 + \frac{3}{2} \times -1 \times (n-4)^{-2} = 0$$

$$24 - \frac{3}{2}(n-4)^{-2} = 0$$

$$(n-4)^{-2} = 16$$

$$\frac{1}{(n-4)^2} = 16$$

$$(n-4)^2 \cdot 16 = 1$$

$$(n-4)^2 = \frac{1}{16}$$

$$n-4 = \frac{1}{4}$$

$$n = \frac{1}{4} + 4 = 4\frac{1}{4}$$

$$\frac{d^2c}{dx^2} = 0 + \frac{-3}{2} \times -2(n-4)^{-3}$$

$$= 3(n-4)^{-3}$$

$$= 3\left(\frac{1}{4}\right)^{-3}$$

$$= \frac{3}{\left(\frac{1}{4}\right)^3} \text{ which is Positive}$$

Hence condition is satisfied and cost will be minimum at  $n = 4\frac{1}{4}$ .

**Illustration: 21**

A firm has revenue function given by  $R = 8D$ , where  $R$  = Gross Revenue and  $D$  = Quantity sold, production cost function is given by  $C = 15000 + 60 \left(\frac{D}{900}\right)^2$ . Find the total profit function and the number of units to be sold to get the maximum profit.

**Solution:**

$$R = 8D$$

$$C = 15000 + 60 \left(\frac{D}{900}\right)^2$$

$$\text{Profit} = 8D - 15000 - 60 \left(\frac{D}{900}\right)^2$$

To find number of units to get the maximum profit

$$\frac{dp}{dD} = 0 \text{ and } \frac{d^2p}{dD^2} \text{ should be -ve}$$

$$\Rightarrow \frac{dp}{dD} = 8 - \frac{60 \cdot 2D}{810000} = 0$$

$$\Rightarrow 8 - \frac{120D}{810000} = 0$$

$$\Rightarrow -\frac{120D}{8,10,000} = -8$$

$$\therefore D = \frac{27000 \times 8}{4} = 54000$$

$$\frac{d^2p}{dD^2} = \frac{-4}{27000} \text{ which is -ve}$$

$P$  is maximum at  $D = 54,000$ .

**Illustration: 22**

The total cost function of a firm  $C = \frac{x^3}{3} - 5x^2 + 28x + 10$ , where  $C$  is total cost and ' $x$ ' is the output. A tax @ ₹2/- per unit of output is imposed and the producer adds it to his cost. If the demand function is given by  $P = 2530 - 5x$ , where ₹'P' is the price per unit of output, Find the profit maximising output and the price at that level.

**Solution:**

$$\text{Given } (C) = \frac{x^3}{3} - 5x^2 + 28x + 10 + 2x$$

$$P = 2530 - 5x$$

$$\text{Revenue} = xp = 2530x - 5x^2$$

$$\text{Profit} = 2530x - 5x^2 + 5x^2 - 28x - 10 - \frac{x^3}{3} - 2x$$

$$= -\frac{x^3}{3} + 2502x - 10 - 2x$$

$$\frac{dp}{dx} = \frac{-3x^2}{3} + 2500 = 0$$

$$x^2 = 2500$$

$$\therefore x = \sqrt{2500} = 50$$

$$\frac{d^2p}{dx^2} = -2x \text{ which is Negative}$$

$$\text{at } x = 50, \frac{d^2p}{dx^2} = -100, \text{ which is (-)ve}$$

$\therefore$  Maximum profit is at  $x = 50$  units

$$\text{Price} = 2530 - 5 \times 50 = 2280$$

### Illustration: 23

Find the Elasticity of Demand for the following:

i.  $P = \frac{10}{(x+2)^2}$

ii.  $P = \frac{4}{(2x+1)^2}$

iii.  $x \cdot p^n = K$ , where n, k are constant.

### Solution:

(i)  $P = \frac{10}{(x+2)^2} = 10(x+2)^{-2}$

Differentiating w.r.t x

$$= \frac{dp}{dx} = 10(-2)(x+2)^{-3} = -20(x+2)^{-3}$$

$$\frac{p}{x} = \frac{10}{x(x+2)^2}$$

$$\text{Elasticity of demand } (E_p) = \frac{dx}{dp} \div \frac{x}{p} = - \left| \frac{dx}{dp} \times \frac{p}{x} \right|$$

$$\frac{dx}{dp} = - \frac{1}{20(x+2)^{-3}} = - \frac{(x+2)^3}{20}$$

$$\frac{dx}{dp} \times \frac{p}{x} = - \frac{(x+2)^3}{20} \times \frac{10}{x(x+2)^2}$$

$$= - \frac{(x+2)}{2x} \quad \therefore E_p = - \left| \frac{dx}{dp} \times \frac{p}{x} \right| = \frac{x+2}{2x}$$

ii)  $P = \frac{4}{(2x+1)^2} = 4(2x+1)^{-2}$

$$\frac{dp}{dx} = 4 \times -2 \times (2x+1)^{-3} = -8(2x+1)^{-3}$$

$$\frac{dx}{dp} = - \frac{1}{8(2x+1)^{-3}} = - \frac{1}{8} (2x+1)^3 = - \frac{(2x+1)^3}{8}$$

$$= \frac{p}{x} = \frac{4}{x(2x+1)^2}$$

$$\text{Elasticity of demand } (E_p) = \frac{(2x+1)^3}{8} \times \frac{4}{x(2x+1)^2} = \frac{(2x+1)}{2x}$$

iii)  $x \times p^n = k$

$$x = \frac{k}{p^n}$$

$$\frac{x}{p} = \frac{k}{p^n \times p} = \frac{k}{p^{n+1}}$$

Differentiating w.r.to x.

$$x \times n.p^{n-1} + p^n \cdot 1 = 0$$

$$\frac{dp}{dx} \cdot xnp^{n-1} + p^n = 0$$

$$= \frac{dp}{dx} \cdot xnp^{n-1} = -p^n$$

$$\frac{dp}{dx} = \frac{-pn}{x.n.p^{n-1}} = \frac{-p}{xn}$$

$$\frac{dx}{dp} = - \frac{xn}{p}$$

$$\frac{p}{x} = \frac{p^{n+1}}{k}$$

$$E_p = \frac{xn}{p} \times \frac{p^{n+1}}{k}$$

$$= \frac{xnp^n}{k}$$

**Illustration: 24**

The Demand curve for x is given by the equation  $P = 24 - \frac{1}{2} \sqrt{q}$ , where P and q denote price and quantity respectively. Find the point price elasticity for  $P = ₹12$ .

**Solution:**

$$\text{Demand } P = 24 - \frac{1}{2} \sqrt{q}$$

$$\frac{dp}{dq} = -\frac{1}{2} \times \frac{1}{2\sqrt{q}} = -\frac{1}{4\sqrt{q}}$$

$$\frac{dq}{dp} = -4\sqrt{q}$$

$$\begin{aligned} \frac{24}{q} - 2\sqrt{q} &= \frac{(24 - 2\sqrt{q})}{q} = \frac{4(24 - 2\sqrt{64})}{\sqrt{64}} \\ &= \frac{4(24 - 16)}{8} = \frac{8}{2} = 4 \end{aligned}$$

$$EP = \frac{dx}{dp} \times \frac{p}{q} = \frac{-4\sqrt{q}(24 - 2\sqrt{q})}{\sqrt{64}}$$

$$P - 24 = -\frac{1}{2} \sqrt{q}$$

$$= -2(p - 24) = \sqrt{q}$$

$$= -2(12 - 24) = \sqrt{q}$$

$$= -24 + 48 = \sqrt{q}$$

$$\sqrt{q} = 24$$

$$\therefore q = 576$$

**Illustration: 25**

The Demand function is  $x = 100 + 4p + 10p^2$ , where x is demand for the commodity at price 'p' compute marginal quantity demand, average quantity demand and hence elasticity of demand, at  $p = 4$

**Solution:**

$$X = 100 + 4p + 10P^2$$

$$\text{Marginal quantity demand} = \frac{dx}{dp}$$

$$\frac{dx}{dp} = 4 + 20P \rightarrow (1)$$

$$\text{Average Quantity demand} = \frac{x}{p} = \frac{100}{p} + 4 + 10p \rightarrow (2)$$

$$E_p = \frac{dx}{dp} \div \frac{x}{p} = \frac{4 + 20p}{\frac{100}{p} + 10p + 4} = \frac{(4 + 20p)p}{100 + 10p^2 + 4p}$$

$$\text{at } P = 4$$

$$= \frac{(4 + 80)4}{100 + 160 + 16} = \frac{28}{23}$$

**Illustration: 26**

Find an expression for price elasticity in the case of following demand functions and evaluate it at the price  $P = 20$

i.  $12Q + 7P = 216$

$$\text{ii. } Q = 2500 - 8P - 2P^2$$

$$\text{iii. } Q = \frac{64}{p^6}$$

$$\text{iv. } Q = \frac{5p}{(1-3p)^2}$$

**Solution:**

$$\text{i) } 7P = 216 - 12Q$$

$$P = \frac{216-12Q}{7} = \frac{1}{7} (216 - 12Q)$$

$$\frac{dP}{dQ} = \frac{1}{7} \times -12 = \frac{-12}{7} = \frac{dQ}{dP} = \frac{-7}{12}$$

$$\frac{P}{Q} = \frac{1}{7} \left( \frac{216}{Q} - 12 \right)$$

$$E_p = - \left[ \frac{-7}{12} \times \frac{1}{7} \left( \frac{216}{Q} - 12 \right) \right]$$

$$E_p = - \left[ \frac{-1}{12} \times \left( \frac{216 - 12Q}{Q} \right) \right]$$

$$12Q = 216 - (7 \times 20) = 216 - 140 = 76$$

$$Q = \frac{76}{12} = 6 \frac{1}{3}$$

$$E_p \text{ at } P = 20$$

$$E_p = \frac{1}{12} \left[ \frac{216 - 12 \times \frac{76}{12}}{\frac{76}{12}} \right]$$

$$= \frac{1}{12} \left( \frac{140 \times 12}{76} \right) = \frac{140}{76} = \frac{35}{19}$$

$$\text{ii) } Q = 2,500 - 8p - 2p^2$$

$$\frac{dQ}{dp} \text{ at } p=20 = -8 - 4p = -8 - 80 = -88$$

$$\frac{Q}{p} = \frac{2500}{p} - 8 - 2P$$

$$= 125 - 8 - 40 = 77$$

$$\frac{p}{Q} = \frac{1}{77}$$

$$E_p = 88 \times \frac{1}{77} = \frac{8}{7}$$

$$\text{iii) } Q = \frac{64}{p^6}$$

$$\frac{dQ}{dp} = \frac{64 \times -6}{p^7}$$

$$\frac{Q}{p} = \frac{64}{p^7} \Rightarrow \frac{p}{Q} = \frac{p^7}{64}$$

$$E_p = \frac{64 \times 6}{p^7} \times \frac{p^7}{64} = 6$$

$$\text{iv) } Q = \frac{5p}{(1-3p)^2}$$

$$\frac{dQ}{dp} = \frac{(1-3P)^2 \cdot 5 - 5P \times 2(1-3P) \cdot -3}{(1-3P)^4}$$

$$\frac{5(1-3P)^2 + 30P(1-3P)}{(1-3P)^4} = \frac{5(1-3P) + 30P}{(1-3P)^3}$$

$$\frac{Q}{P} = \frac{5}{(1-3P)^2} = \frac{P}{Q} = \frac{(1-3P)^2}{5}$$

$$E_p = \frac{5(1-3P) + 30P}{(1-3P)^3} \times \frac{(1-3P)^2}{5}$$

$$= \frac{5 - 15P + 30P}{5(1-3P)} = \frac{1 - 3P + 6P}{1 - 3P} = \frac{1 + 3P}{1 - 3P}$$

$$= \frac{1 + 60}{1 - 60} = \frac{61}{-59}$$

**Illustration: 27**

The total revenue from sale of 'x' units is given by the equation  $R = 100x - 2x^2$ , calculate the point price elasticity of demand, when marginal revenue is 20.

**Solution:**

$$R = 100x - 2x^2$$

$$\text{Price} = 100 - 2x$$

$$MR = \frac{dR}{dx} = 100 - 4x$$

$$\frac{P}{x} = \frac{100}{x} - 2$$

$$\frac{dp}{dx} = -2 = \frac{dx}{dp} = \frac{1}{2}$$

$$E_p = \frac{1}{2} \times \left( \frac{100}{x} - 2 \right)$$

$$= \frac{50}{x} - 1$$

$$= \frac{50}{20} - 1$$

$$= \frac{5}{2} - 1$$

$$= \frac{5-2}{2} = \frac{3}{2}$$

$$100 - 4x = 20$$

$$4x = 80$$

$$x = 20$$

**Illustration: 28**

Prove that the elasticity of demand for the following is constant  $x = 3(p^{-2})$ , Where P and X are the price & quantity demanded respectively.

**Solution:**

$$E_p = - \left| \frac{dx}{dp} \times \frac{p}{x} \right|$$

$$x = 3(p^{-2})$$

Differentiate w.r.to 'x'

$$\Rightarrow 1 = 3(-2 \cdot p^{-3}) \frac{dp}{dx}$$

$$\Rightarrow 1 = -6p^{-3} \cdot \frac{dp}{dx}$$



$$\Rightarrow \frac{dp}{dx} = -\frac{p^3}{6}$$

$$\therefore \frac{dx}{dp} = -\frac{6}{p^3} \quad \text{– Equation (1)}$$

$$\text{Now } \frac{x}{p} = \frac{3}{p^3}$$

$$\Rightarrow \frac{p}{x} = \frac{p^3}{3} \quad \text{– Equation (2)}$$

From equations (1) & (2)

$$\therefore E_p = -\left| \frac{dx}{dp} \times \frac{p}{x} \right|$$

$$= -\left(-\frac{6}{p^3} \times \frac{p^3}{3}\right)$$

$$= 2 \text{ (proved)}$$

### Illustration: 29

The total cost (C) and the total revenue (R) of a firm are given  $C(x) = x^3 + 60x^2 + 8x$ ;  $R(x) = 3x^3 - 3x^2 + 656x$ ,  $x$  being output. Determine, the output for which the firm gets maximum profit. Also obtain the maximum profit.

### Solution:

$$C = x^3 + 60x^2 + 8x$$

$$R = 3x^3 - 3x^2 + 656x$$

$$\text{Profit} = 3x^3 - 3x^2 + 656x - x^3 - 60x^2 - 8x$$

$$= 2x^3 - 63x^2 + 648x = (P)$$

Derivative w.r.to  $x$

$$\frac{dP}{dx} = 6x^2 - 126x + 648 = 0$$

$$x^2 - 21x + 108 = 0$$

$$x^2 - 9x - 12x + 108 = 0$$

$$x(x - 9) - 12(x - 9) = 0$$

$$(x - 12)(x - 9) = 0; x = 12 \text{ or } 9$$

$$\frac{d^2P}{dx^2} = 2x - 21$$

$$\text{at } x = 9$$

$$\frac{d^2P}{dx^2} = 18 - 21 = -3 < 0$$

$$\therefore P \text{ is maximum at } x = 9$$

$$\text{at } x = 12$$

$$\frac{d^2P}{dx^2} = 24 - 21 = 3 > 0$$

$$\therefore P \text{ is minimum at } x = 12$$

$$P = 2x^3 - 63x^2 + 648x$$

$$\text{at } x = 9$$

$$\text{Profit } P = 2 \times (9)^3 - 63(9)^2 + 648(9)$$

$$729 \times 2 - 63 \times 81 + 648 \times 9 = 2187$$



**Illustration: 30**

A monopolist has demand curve  $x = 106 - 2p$  and average cost curve  $(AC) = 5 + x/50$ . The total revenue is  $(R) = xp$ , determine the most profitable output and maximum profit.

**Solution:**

$$x = 106 - 2p \Rightarrow x - 106 = -2p$$

$$P = \frac{x - 106}{-2} = \frac{106 - x}{2}$$

$$R = \frac{106x - x^2}{2}$$

$$\text{Total Cost} = 5x + \frac{x^2}{50}$$

$$\text{Profit} = \frac{106x - x^2}{2} - 5x - \frac{x^2}{50}$$

$$\frac{dp}{dx} = \frac{(106 - 2x)}{2} - 5 - \frac{2x}{50} = 0$$

$$\frac{dp}{dx} = 53 - x - 5 - \frac{2x}{50} = 0$$

$$48 = x \left( 1 + \frac{1}{25} \right)$$

$$X = \frac{1200}{26}$$

$$\frac{d^2p}{dx^2} = \frac{-26}{25} < 0$$

$$\therefore P \text{ is maximum at } x = \frac{1200}{26}$$

**Illustration: 31**

The total cost function of a manufacturing firm is given by  $C = 2x^3 - x^2 + 3x + 5$  and the Marginal Revenue =  $8 - 3x$ ,  $X$  = output, determine the most profitable output of the firm.

**Solution:**

$$C = 2x^3 - x^2 + 3x + 5$$

$$MR = 8 - 3x$$

$$MC = \frac{dc}{dx} = 6x^2 - 2x + 3$$

Profit maximum at  $MC = MR$

$$6x^2 - 2x + 3 = 8 - 3x$$

$$6x^2 + x - 5 = 0$$

$$6x^2 + 6x - 5x - 5 = 0$$

$$6x(x + 1) - 5(x + 1) = 0$$

$$(x + 1)(6x - 5) = 0$$

$$X = -1$$

$$x = \frac{5}{6} \quad \therefore x = \frac{5}{6}$$

**Illustration: 32**

A company is planning to market a new model of a doll. Rather than setting the selling price of the doll based only on production cost estimation management polls the retailers of the doll to see



how many dolls they will buy for various prices. From this survey, it is determined at the unit demand function (the relationship between the amount 'x' each retailer would buy and the price he would pay) is  $x = 30,000 - 1500P$ . The fixed cost of the production of the dolls are found to be ₹ 28,000 and cost of Material & labour to produce each doll is estimated to be ₹ 8 per unit. What price should the company charge retailer in order to obtain a maximum profit? Also find the maximum profit.

**Solution:**

$$x = 30000 - 1500P$$

$$x - 30000 = -1500P$$

$$\therefore P = \frac{30000 - x}{1500}$$

$$\text{Revenue} = \frac{30000x - x^2}{1500}$$

$$C = 8x + 28000$$

$$\text{Profit} = \frac{30000x - x^2}{1500} - 8x - 28000$$

$$\frac{dp}{dx} = \frac{1}{1500} (30000 - 2x) - 8 = 0$$

$$= 30000 - 2x - 12000 = 0$$

$$-2x = -18000$$

$$x = \frac{18000}{2} = 9000$$

$$\frac{d^2p}{dx^2} = -2, \text{ which is Negative}$$

$$\text{Profit} = \frac{30000 \times 9000 - 9000^2}{1500} - 72,000 - 28,000$$

$$= 180000 - \frac{810000}{15} - 72,000 - 28,000 = 26,000$$

**Illustration: 33**

Assume that for a closed economy  $E = C + I + G$ ; Where E= total expenditure on consumption goods, I = Exp. on Investment goods and G = Govt. Spending. For equilibrium, we must have  $E = Y$ , Y being total income received.

For a certain Economy, it is given that  $C = 15 + 0.9Y$ , where  $I = 20 + 0.05Y$  and  $G = 25$ . Find the equilibrium values of Y, C and I. How will these change, if there is no Government spending?

**Solution:**

$$E = 15 + 0.9Y + 20 + 0.05Y + 25$$

$$E = 60 + 0.95Y = (1)$$

$$\text{As given } E = Y = 60 + 0.95Y$$

$$0.05Y = 60$$

$$\therefore Y = \frac{60}{.05} = 1200$$

$$C = 15 + 0.9 \times 1200 = 1095$$

$$I = 20 + 0.05 \times 1200 = 80$$

When there is no government spending.

$$Y = 35 + 0.95Y$$

$$\text{or, } 0.05Y = 35$$

$$\therefore Y = \frac{35}{0.05} = 700$$

$$C = 15 + 630 = 645$$

$$I = 20 + 35 = 55$$

**Illustration: 34**

A demand function of an item is  $P = 8/(x+1) - 2$  and supply function is  $P = (x+3)/2$ , determine the equilibrium price and consumer's surplus.

**Solution:**

Equilibrium price = Demand = Supply

$$\frac{8}{x+1} - 2 = \frac{x+3}{2}$$

$$\frac{8-2(x+1)}{x+1} = \frac{x+3}{2}$$

$$(8 - 2x - 2)2 = (x + 3) (x + 1)$$

$$16 - 4x - 4 = x^2 + 4x + 3$$

$$-x^2 - 8x + 9 = 0$$

$$x^2 + 8x - 9 = 0$$

$$x^2 - x + 9x - 9 = 0$$

$$x(x - 1) + 9(x - 1) = 0$$

$$(x - 1) (x + 9) = 0$$

$$x = 1, x = -9$$

$$\text{Price} = \frac{1+3}{2} = \frac{4}{2} = 2$$

$$\text{Consumer's surplus} = \int_0^1 \left( \frac{8}{x+1} - 2 \right) dx - 2 \times 1$$

$$= \int_2^4 [8 \log (x + 1) - 2x] - 2$$

$$= [8 \cdot \log 2 - 2] - 2$$

$$= 8 \log 2 - 4$$

**Illustration: 35**

The demand function for a particular brand of pocket calculator is stated below,  $P = 75 - 0.3Q - 0.05Q^2$ , Find the consumer's surplus at a quantity of 15 calculators.

**Solution:**

$$\text{Price} = 75 - 0.30 \times 15 - 0.05 (15^2)$$

$$= 75 - 4.5 - 0.5 \times 225$$

$$= 75 - 15.75 = 59.25$$

Consumer's surplus

$$= \int_0^{15} (75 - 0.3Q - 0.05Q^2) dQ - (59.25 \times 15)$$

$$= \int_0^{15} \left( 75Q - \frac{0.3Q^2}{2} - \frac{0.5Q^3}{3} \right) - (59.75 \times 15)$$



$$\begin{aligned} &= [(1125 - 33.75 - 56.25) - 0] - 888.75 \\ &= 1035 - 888.75 \\ &= 146.25 \end{aligned}$$

**Illustration: 36**

The demand and supply function under perfect competition are  $Y = 16 - x^2$  and  $Y = 2(x^2 + 2)$  respectively. Find the market price, consumer's surplus and producer's surplus.

**Solution:**

Under perfect competition market price is: demand = supply i.e.

$$16 - x^2 - 2x^2 - 4 = 0$$

$$-3x^2 + 12 = 0$$

$$-3x^2 = -12$$

$$\therefore x^2 = 12/3$$

$$x = \sqrt{\frac{12}{3}} = 2 \text{ units}$$

Consumer's surplus =

$$= \int_0^2 (16 - x^2) dx - (12 \times 2)$$

$$= \int_0^2 \left(16x - \frac{x^3}{3}\right) - 24$$

$$= 32 - \frac{8}{3} - 24$$

$$= 5 \frac{1}{3}$$

Producer's surplus =

$$= 2 \times 12 - \int_0^2 2(x^2 + 2) dx$$

$$= 24 - \int_0^2 \left(\frac{2x^3}{3} + 4x\right)$$

$$= 32 - \frac{16}{3} - 8 - 0$$

$$= 32 - \frac{16}{3}$$

$$= 26 \frac{2}{3}$$

**Illustration: 37**

The demand function is  $Y = 85 - 4x - x^2$ , 'y' is the price and 'x' is the quantity demand. Find the consumer's surplus for  $Y = 64$ .

**Solution:**

$$\text{Quantity is } 85 - 4x - x^2 = 64$$

$$\Rightarrow -x^2 - 4x + 21 = 0$$

$$\Rightarrow x^2 + 4x - 21 = 0$$

$$\Rightarrow x^2 + 7x - 3x - 21 = 0$$

$$\Rightarrow x(x + 7) - 3(x + 7) = 0$$

$$\Rightarrow (x - 3)(x + 7) = 0$$

$\therefore x = 3$  or  $x = -7$ , not acceptable

Consumer's surplus =

$$= \int_0^3 (85 - 4x - x^2) dx - (3 \times 64)$$

$$= \left[ 85x - \frac{4x^2}{2} - \frac{x^3}{3} \right]_0^3 - 192$$

$$= 255 - 18 - 9 - 192$$

$$= 36$$

**Illustration: 38**

Find whether the following commodities are complementary or competitive (or) substitutes, where  $P_1, P_2$  and  $X_1, X_2$  are prices and quantities respectively of the two commodities.

i.  $x_1 = P_1^{-1.7} \cdot P_2^{0.8}$  ;  $x_2 = P_1^{0.5} \cdot P_2^{-2}$

ii.  $x_1 = \frac{4}{P_1^2 P_2}$  ;  $x_2 = \frac{16}{P_1 P_2^2}$

iii.  $x_1 = P_1^{-8} \cdot P_2^{1.2}$  ;  $x_2 = P_1^{0.2} \cdot P_2^{0.6}$

iv.  $x_1 = P_1^{-1.1} \cdot P_2^{0.3}$  ;  $x_2 = P_1^{0.2} \cdot P_2^{0.6}$

v.  $x_1 = 1 - 2P_1 + P_2$  ;  $x_2 = 5 - 2P_1 - 3P_2$

vi.  $x_1 = \frac{P_2^{0.6}}{P_1^{1.5}}$  ;  $x_2 = \frac{P_1^{0.1}}{P_2^{0.1}}$

**Solution:**

(i)  $x_1 = P_1^{-1.7} \cdot P_2^{0.8}$  ;  $x_2 = P_1^{0.5} \cdot P_2^{-2}$

Differentiate partially  $x_1$  w.r.to  $p_2$

$$\begin{aligned} \frac{\partial x_1}{\partial p_2} &= P_1^{-1.7} (0.8) P_2^{-0.2} \\ &= \frac{0.8}{P_1^{1.7} \times P_2^{0.2}} \quad \text{which is greater than zero} \end{aligned}$$

Again differentiating partially  $x_2$  w.r.to  $p_1$

$$\begin{aligned} \frac{\partial x_2}{\partial p_1} &= P_2^{-2} (0.5) P_1^{-0.5} \\ &= \frac{0.5}{P_2^{-2} \cdot P_1^{0.5}} \quad \text{which is greater than zero} \end{aligned}$$

Hence the commodities are substitutes.

(ii)  $x_1 = \frac{4}{P_1^2 P_2}$  ;  $x_2 = \frac{16}{P_1 P_2^2}$

Partially differentiating  $x_1$  w.r.to  $p_2$

$$\frac{\partial x_1}{\partial p_2} = \frac{-4}{P_1^2 \cdot P_2^2} \quad \text{which is less than zero}$$

Again partially differentiating  $x_2$  w.r.to  $p_1$

$$\frac{\partial x_2}{\partial p_1} = \frac{-16}{P_1^2 \cdot P_2^2} \quad \text{which is also less than zero}$$

Therefore, commodities are complementary.

$$(iii) \quad x_1 = P_1^{-0.8} \cdot P_2^{1.2}; \quad x_2 = P_1^{0.2} \cdot P_2^{0.6}$$

Differentiating partially  $x_1$  w.r.to  $p_2$

$$\frac{\partial x_1}{\partial p_2} = P_1^{-0.8} (1.2) P_2^{0.2} \quad \text{which is greater than zero}$$

Similarly differentiating partially  $x_2$  w.r.to  $p_1$

$$\begin{aligned} \frac{\partial x_2}{\partial p_1} &= P_2^{0.6} (0.2) P_1^{-0.8} \\ &= \frac{(0.2) P_2^{0.6}}{P_1^{0.8}} \quad \text{which is greater than zero} \end{aligned}$$

Therefore the commodities are substitutes.

$$(iv) \quad x_1 = P_1^{-1.1} \cdot P_2^{0.3}; \quad x_2 = P_1^{0.2} \cdot P_2^{0.6}$$

Differentiate partially  $x_1$  w.r.to  $p_2$

$$\frac{\partial x_1}{\partial p_2} = \frac{P_1^{-1.1} (0.3)}{P_2^{0.7}} = \frac{(0.3)}{P_1^{1.1} \cdot P_2^{0.7}} \quad \text{which is greater than zero.}$$

Similarly differentiate partially  $x_2$  w.r.to  $p_1$

$$\frac{\partial x_2}{\partial p_1} = P_2^{0.6} (0.2) P_1^{-0.8} = \frac{(0.2) P_2^{0.6}}{P_1^{0.8}} \quad \text{which is also greater than zero.}$$

Therefore, the commodities are substitutes.

$$(v) \quad x_1 = 1 - 2P_1 + P_2; \quad x_2 = 5 - 2P_1 - 3P_2$$

Differentiating partially  $x_1$  w.r.to  $p_2$

$$\frac{\partial x_1}{\partial p_2} = 1, \quad \text{which is greater than zero.}$$

Similarly, differentiating partially  $x_2$  w.r.to  $p_1$

$$\frac{\partial x_2}{\partial p_1} = -2, \quad \text{which is less than zero.}$$

Therefore, the relationship between the commodities cannot be established.

$$(vi) \quad x_1 = \frac{P_2^{0.6}}{P_1^{1.5}}; \quad x_2 = \frac{P_1^{0.1}}{P_2^{0.1}}$$

Differentiating partially  $x_1$  w.r.to  $p_2$

$$\begin{aligned} \frac{\partial x_1}{\partial p_2} &= \frac{1}{P_1^{1.5}} (0.6) P_2^{-0.4} \\ &= \frac{(0.6)}{P_1^{1.5} \cdot P_2^{0.4}} \quad \text{which is greater than zero.} \end{aligned}$$

Similarly, differentiating partially  $x_2$  w.r.to  $p_1$

$$\begin{aligned} \frac{\partial x_2}{\partial p_1} &= \frac{1}{P_2^{0.1}} \cdot \frac{0.1}{P_1^{0.9}} \\ &= \frac{0.1}{P_2^{0.1} \cdot P_1^{0.9}} \quad \text{which is greater than zero.} \end{aligned}$$

Therefore, the commodities are substitutes.

**Illustration 39**

1. K Ltd. sells output in a perfectly competitive market. The average variable cost function of K Ltd. is

$$AVC = 300 - 40Q + 2Q^2$$

K Ltd has an obligation to pay ₹ 500 irrespective of the output produced.

What is the price below which K Ltd. has to shut down its operation in the short run?

**Solution:**

A firm has to shut down its operation, if the price is less than average variable cost.

Under perfect competition

$$P = MR$$

i.e. Price is equal to marginal revenue. The firm will continue its operation under the short run so long as price is at least equal to average variable cost.

Thus the equilibrium price where the firm will shut down is the minimum AVC i.e. the average variable cost.

$$AVC = 300 - 40Q + 2Q^2$$

$$AVC \text{ is minimum where } \frac{d(AVC)}{dQ} = 0$$

$$\text{i.e. } \frac{d(AVC)}{dQ} = -40 + 4Q = 0$$

$$\text{i.e. } Q = 10 \text{ units.}$$

when the firm is producing 10 units,

$$\begin{aligned} AVC &= 300 - 40Q + 2Q^2 \\ &= 300 - 40(10) + 2(10)^2 \\ &= 300 - 400 + 200 = 100 \end{aligned}$$

If the price falls before ₹ 100 the firm has to shut down its operation under short run.

**Illustration 40**

J Ltd is operating in a perfectly competitive market. The price elasticity of demand and supply of the product estimated to be 3 and 2 respectively. The equilibrium price of the product is ₹ 100. If the government imposes a specific tax of ₹ 10 per unit, what will be the new equilibrium price?

**Solution**

Distribution of tax burden between buyers and sellers is in ratio of elasticity of supply to elasticity of demand.

$$\text{Thus tax burden borne by the buyer} = ₹ 10 \times \frac{2}{5} = ₹ 4.$$

If the tax burden borne by buyer is ₹ 4, new equilibrium price will be  $100 + 4 = ₹ 104$

**Illustration 40**

The total cost function for a monopolist is given by

$$TC = 900 + 40Q^2$$

The demand function for the good produced by the monopolist is given by

$$2Q = 48 - 0.08P$$



What will be the profit maximising price?

**Solution:**

demand function is given by

$$2Q = 48 - 0.08 P$$

$$\text{or, } 2Q - 48 = -0.08 P$$

$$\text{or, } 48 - 2Q = 0.08 P$$

$$\text{or, } P = 600 - 25Q$$

$$TR = PQ$$

$$= 600Q - 25Q^2$$

TC is given by ,

$$TC = 900 + 40 Q^2$$

The first order condition for profit maximisation is  $MR = MC$

$$TR = 600Q - 25Q^2$$

$$MR = \frac{dTR}{dQ} = 600 - 50Q$$

$$MC = \frac{d(TC)}{dQ} = 80Q$$

For maximising profit

$$MR = MC$$

$$\text{i.e. } 600 - 50Q = 80Q$$

$$Q = \frac{600}{130} = 4.6 \text{ units}$$

Equilibrium Price =

$$P = 600 - 25 Q = 600 - 25(4.6)$$

$$= 600 - 115$$

$$= ₹ 485$$

i.e. profit maximising price is ₹ 485

**Illustration 42**

S Ltd a monopolist aims at profit maximisation. The fixed cost of the firm is ₹ 200 and the average variable cost of the firm is constant at ₹ 30 per unit. S Ltd sells goods in West Bengal and Kerala . The estimated demand function for the goods in West Bengal and Kerala are

$$P_w = 40 - 2.5 Q_w$$

$$P_k = 120 - 10 Q_k$$

If price discrimination is practiced by S Ltd. ,What will be the profit maximising output?

**Solution:**

When price discrimination is practiced profit maximising condition is



$$MR_w = MC \dots (1)$$

$$MR_k = MC \dots (2)$$

$$\text{Now, } P_w = 40 - 2.5 Q_w$$

$$TR_w = 40 Q_w - 2.5 Q_w^2$$

$$MR_w = 40 - 5Q_w$$

$$\text{and } P_k = 120 - 10 Q_k$$

$$TR_k = 120Q_k - 10Q_k^2$$

$$MR_k = 120 - 20 Q_k$$

Since average variable cost is constant at ₹ 30 per unit ,then

$$MC = 30$$

$$40 - 5Q_w = 30$$

$$Q_w = 2 \text{ units}$$

$$\& 120 - 20 Q_k = 30$$

$$\text{i.e. } Q_k = \frac{90}{20} = 4.5 \text{ units}$$

Thus profit maximising output in West Bengal will be 2 units and in Kerala will be 4.5 units.

Thus profit maximising output for the monopolist = 2 + 4.5 = 6.5 units.

#### Illustration 43

The total cost function of a monopolist is given by

$$C = 50 + 40x = 50 + 40 (x_1 + x_2)$$

The total demand is given by

$$P = 100 - 2x$$

The demand function of the segmented market are

$$P_1 = 80 - 2.5x_1$$

$$P_2 = 180 - 10 x_2$$

If the price discrimination is practised by the monopolist , what will be the equilibrium output in each segment and what will be the price ?

Prove that the market with the higher elasticity will have the lower price.

#### Solution

The firm aims at the maximisation of profit .

$$\pi = R_1 + R_2 - C$$

$$R_1 = P_1 x_1 = (80 - 2.5x_1)x_1$$

$$= 80 x_1 - 2.5x_1^2$$

$$MR_1 = 80 - 5x_1 \dots\dots\dots(1)$$

$$R_2 = P_2 x_2 = (180 - 10x_2) x_2$$

$$= 180x_2 - 10x_2^2$$

$$MR_2 = 180 - 20x_2 \dots\dots\dots(2)$$



$$\begin{aligned}C &= 50 + 40x \\ &= 50 + 40(x_1 + x_2) \\ MC &= \frac{dc}{dx_1} = \frac{dc}{dx_2} = \frac{dc}{dx} = 40 \dots \dots \dots (3)\end{aligned}$$

Then, equating (1) & (3)

$$\begin{aligned}80 - 5x_1 &= 40 \\ x_1 &= 8\end{aligned}$$

and, equating (2) & (3)

$$\begin{aligned}180 - 20x_2 &= 40 \\ x_2 &= 7\end{aligned}$$

Total output = 8 + 7 = 15 units

$$P_1 = 80 - 2.5x_1 = ₹ 60$$

$$P_2 = 180 - 10x_2 = ₹ 110$$

The elasticities are

$$e_1 = \frac{dx_1}{dp_1} \cdot \frac{p_1}{x_1}$$

$$\text{Now } P_1 = 80 - 2.5x_1$$

$$x_1 = 32 - 0.4 P_1$$

$$\frac{dx_1}{dp_1} = 0.4$$

$$\text{then } e_1 = 0.4 \times \frac{60}{8} = 3$$

$$\text{Similarly } e_2 = \frac{dx_2}{dp_2} \cdot \frac{p_2}{x_2} = 1.57$$

Thus  $e_1 > e_2$  and accordingly  $p_1 < p_2$

i.e. market with the higher elasticity will have the lower price.

### 5.3 PRODUCT POLICIES

#### 5.3.1 Definition of 'Product Line'

A group of related products manufactured by a single company. For example, a cosmetic company's makeup product line might include foundation, concealer, powder, blush, eyeliner, eyeshadow, mascara and lipstick products that are all closely related. The same company might also offer more than one product line. The cosmetic company might have a special product line geared toward teenagers and another line geared toward women older than 60, in addition to its regular product line, that can be used by women of any age.

A good way for a company to try to expand its business is by adding to its existing product line. This is because people are more likely to purchase products from brands with which they are already familiar. For example, a frozen pizza company may wanted to increase its market share by adding frozen breadsticks and frozen pastas to its product line.

#### Diagrammatic examples of Product Line



#### 5.3.2 Product Line Extension

A product line extension is a new product that is slightly different to a company's existing range. An example would be a new pack size of an existing food product line, such as children's breakfast cereals. In retailing, an example is the opening of a new branch of a franchised store, or a convenience-store version of a supermarket chain.



A product line extension gives customers more choice under the same brand.

### **Risk**

Introducing a variation to an existing product line reduces the risk in new product development. Your customers are familiar with your existing product line; provided your line extension offers the same level of quality as existing products in the line and meets specific needs not previously covered by the line, your customers may feel confident choosing the new product.

### **Loyalty**

A line extension helps maintain customer loyalty. When customers want to buy a higher-specification product, they may find that the original supplier does not have a suitable version; instead, they choose a competitor's offering. By extending a product line to include higher value models, you can offer customers the choice of buying from a familiar brand. That can help to maintain customer loyalty.

### **Market Expansion**

Product line extensions can expand a market by giving customers greater choice and providing products that meet customer needs more precisely. You can offer higher- or lower-price versions with different features so that your range meets the needs of customers that you could not satisfy before.

### **Versions**

Creating different versions of a product is a low-risk strategy for product line extension. A software product, for example, can extend in both directions, offering versions for developers, professional users, consumers and students, with a budget version for cost-conscious consumers. Each version can have additional or reduced features compared to a core version. In the software example, the extended product line may attract users at either end of the scale who had not previously considered the brand.

### **Development**

To plan a product line extension, carry out market research to identify gaps in the market or attractive segments that competitors currently supply. Using the software example, ask customers which features they find most important and plan versions that meet those requirements.

### **Branding**

Creating new products with an existing brand name can increase the chance of acceptance by existing customers. However, if you are planning to introduce lower-priced line extensions, the question of branding is more difficult. Low-price products could harm your main brand if they offer lower quality. In that scenario, it would be better to use a different brand name. If the lower-price product offers the same quality as the main brand, you can position it as an affordable version of your main brand.

## Product Mix

A range of associated products that yields larger sales revenue when marketed together than if they were marketed individually or in isolation from others.



### 5.3.3 Product mix is the variety of products a company sells.

Product mix, also known as product assortment, refers to the total number of product lines that a company offers to its customers. For example, a small company may sell multiple lines of products. Sometimes, these product lines are fairly similar, such as dish washing liquid and bar soap, which are used for cleaning and use similar technologies. Other times, the product lines are vastly different, such as diapers and razors. The four dimensions to a company's product mix include width, length, depth and consistency.

#### Width

The width of a company's product mix pertains to the number of product lines that a company sells. For example, if a company has two product lines, its product mix width is two. Small and upstart businesses will usually not have a wide product mix. It is more practical to start with some basic products and build market share. Later on, a company's technology may allow the company to diversify into other industries and build the width of the product mix.

#### Length

Product mix length pertains to the number of total products or items in a company's product mix, according to Philip Kotler's textbook "Marketing Management: Analysis, Planning, Implementation and Control." For example, ABC company may have two product lines, and five brands within each product line. Thus, ABC's product mix length would be 10. Companies that have multiple product lines will sometimes keep track of their average length per product line. In the above case, the average length of an ABC Company's product line is five.

#### Depth

Depth of a product mix pertains to the total number of variations for each product. Variations can include size, flavour and any other distinguishing characteristic. For example, if a company sells three sizes and two flavours of toothpaste, that particular brand of toothpaste has a depth of six. Just like length, companies sometimes report the average depth of their product lines; or the depth of a specific product line.

#### Consistency

Product mix consistency pertains to how closely related product lines are to one another--in terms of use, production and distribution. A company's product mix may be consistent in distribution but vastly different in use. For example, a small company may sell its health bars and health magazine in retail stores. However, one product is edible and the other is not. The production consistency of these products would vary as well.

### 5.3.4 Product Market Mix Strategy

Small companies usually start out with a product mix limited in width, depth and length; and have a high level of consistency. However, over time, the company may want to differentiate products or acquire new ones to enter new markets. A company can also sell the existing products to new markets by coming up with new uses for their product.

---

- **Features/benefits analysis**

- Would additional features or services add value to your offering?
- Are there elements of your offering which are unnecessary in the eyes of your customers and can be removed?

- **Unique selling proposition of your products**

- **Proposed new products**

- Have you included in your range those products or services which are more likely to be in demand in future?
- Have you some product or service lines that have highly seasonal demand - can you maximise the 'quiet times'?
- How does the profitability of each product line compare?
- How does the future potential for each product line compare?

### **Product Strategy**

A product strategy identifies, in broad terms, how you plan to sell your products to your marketplace. It documents how the people in your marketplace (your clients) think about your products and business. It documents how your business positions its products and services and it contains your strategies for selling.

A product strategy can encompass any number of products, depending on the nature of your business. You could have one strategy for each major product or, perhaps, the same strategy for all of them.

For example, an organisation that manufactures and sells high quality vacuum cleaners may sell several product lines but they might all be positioned as high quality premium products. A more diverse organisation selling different products such as finance, travel and music into different markets would need several product strategies.

A product strategy is a document containing any of the following:

- business objectives
- descriptions of target market(s), usually based on results of market research
- results of research about your potential clients and their needs
- how you want your product to be viewed by your clients
- product features and benefits
- selling strategies
- how your product features and pricing compare to your competitors'
- product changes that might enable better market positioning of your product.

If you were an electrician, your product is the service you offer. Your product strategy helps you determine exactly what services to offer. Do you focus on industrial electrical work or household? Do you offer simple services, more complex services such as re-wiring or both? Are you going to do business with developers of huge multi-residential complexes?

Developing a product strategy helps you analyse why clients should use your service instead of your competitors'. You can do this by analysing your competitors and differentiating your service. It might be your experience or prompt service. You can then use those particular features and benefits to market your service. This is called product positioning.

A product strategy gives you an idea of how you should price your service. Will you undercut the competition or charge more because you're worth it?

### Benefits of having a product strategy

A product strategy provides direction for your sales activities and, so, makes selling easier. Let's look at some of the other benefits.

- It helps you analyse and, so, **know your product** - product knowledge. By examining all the features of your product you may be able to identify benefits you hadn't thought of before. It might be that you realise the different colours you offer give the product an appearance that appeals to market segments you hadn't previously identified.
- It provides **client focus** - you're not just selling a product, you're helping clients buy. By putting yourself in the client's shoes you can tune into their needs.
- It gives shape and form to your **sales messages**.
- If you share your product strategy with everyone in the business, it often means **everyone in the business gives clients the same message**.
- It helps you analyse the competition and **position your products competitively**.
- It helps you **price your products competitively**.
- It keeps you up-to-date, **forward looking and pro-active**.

All these together work to give you the best chance of selling success.



### 5.3.5 Price Strategy

Price affects how much of your product is sold, to whom it is sold, what services must go with it and ultimately how much profit you make.

If you are currently developing a new product or service you will know that setting a price can be one of the most difficult decisions you make in business. On the other hand, you may be in a position that having set a price, it is now difficult to make necessary adjustments without sending the wrong signals to your market. When pricing is handled sensitively it can have a dramatic effect on the profitability of your firm.

There are no infallible rules for setting the right price, as different businesses at different times use pricing to achieve quite different objectives.

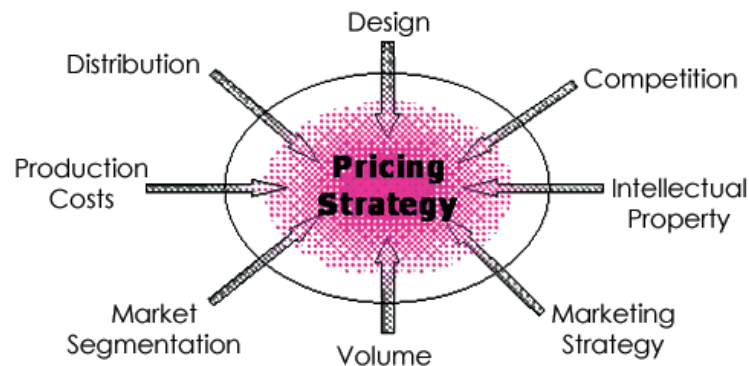

These are some of the strategic factors you need to consider regarding your pricing.

### 1. Positioning

You know the old saying, "You get what you pay for." Your price affects the perception of your product in the market. For example, you could position yourself as the low cost leader, like Wal-Mart has done with their "price rollback" promotions and their new slogan: "Save money. Live better." By contrast, consider Acura's recent "Excuses" campaign: "There are excuses for spending money on luxury, and then there are reasons." On an exclusive luxury product, a low price may signal lower quality.

### 2. Cost

You're in business to make a profit, and you probably have a good idea just how much profit you'd like to make on your investment. If you have outside investors, they certainly do. Calculate the variable cost per sale and the fixed overhead costs. What price do you need to be at in order to achieve your desired profitability based on your sales projections? Be sure to combine this with your demand curve data, i.e., keep in mind that changing your price will change your sales forecast.

### 3. Environmental Factors

Are there any external constraints that could affect pricing? For example, most cities set a standard rate for taxicabs. In the medical field, insurance companies and government programs will only reimburse a certain price. Also, consider how your competitors may react to your pricing. Will too low a price from you trigger a price war, or at least a new price point that may reduce your competitive differentiation?

### 4. Demand Curve

Generally speaking, all other things being equal, a lower price will increase demand and a higher price will reduce demand. Any time you change pricing, track the demand changes closely. In most industries, you can't be constantly changing pricing, but you will still, over time, gain insights that will allow you to optimize your profitability. You can supplement this with market research, asking research participants if they would buy the product or service at various price points.

### 5. Market Control

A good demand curve model can help you optimize your pricing for maximum profitability, but that may not always be your best strategy. For example, lower prices when you first launch may be critical to help you gain market share against established competitors. And higher revenues at a slim profit, or even a loss, signal that the company will likely reach profitability later by achieving economies of scale, volume discounts from suppliers, or upsells to existing customers of higher-profit products. Consider



Amazon.com, which was posting record-breaking revenues, but took six years to achieve profitability because they had held their prices low in order to achieve market penetration. On the flip side, lower prices can be used by an established business to hedge against competitive threats from newcomers.

### 6. Psychological Factors

Even if you don't have any direct competition, customers will have a concept of what constitutes a fair price based on other things they are familiar with. For example, I wonder if peanut butter and jelly would have been so successful if one cost five times what the other did. Remember that you're not only competing against your direct competitors, but potentially against everything else they can spend their money on. Also, there are often key price points that will make a significant difference in people's willingness to buy. For example, whenever a consumer electronics product breaks the ₹100 or ₹50 price point, there's usually a surge in sales. And yes, ".99" pricing really does seem to work (typically about 10 percent more buyers), even though logically it shouldn't.

### 7. Value

What is your product worth to your customers? Does it make or save them money? If so, its value should significantly exceed its price. If it does, you can base your pricing more on its value to them than what it costs you to produce it. If it doesn't, you probably need to rethink your offering!

As you've probably realized by now, because there are so many different competing factors, there are a lot of different ways to calculate the actual number for your price.

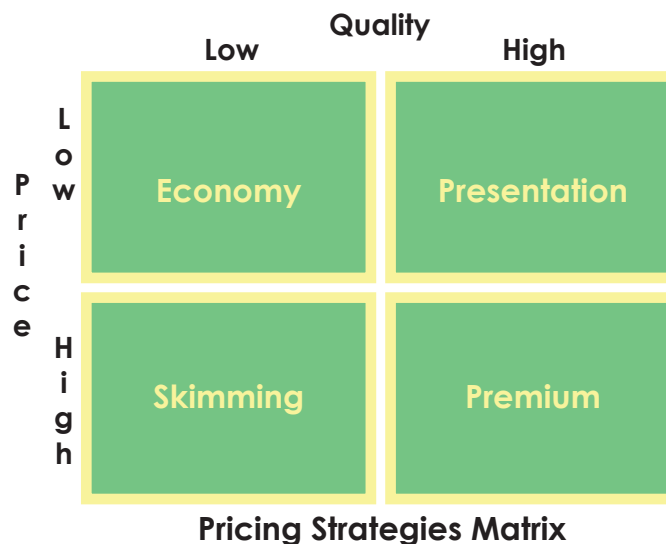

The diagram depicts four key pricing strategies namely premium pricing, penetration pricing, economy pricing, and price skimming which are the four main pricing policies/strategies. They form the bases for the exercise.

### Promotion Strategies

Promotion is the method you use to spread the word about your product or service to customers, stakeholders and the broader public. A successful product or service means nothing unless the benefit of such a service can be communicated clearly to the target market.

### Objectives of Promotional Strategy

Promotional strategy objectives vary among organizations. Some use promotion to expand their markets, others to hold their current positions, still others to present a corporate viewpoint on a public issue. Promotional strategies can also be used to reach selected markets. Most sources identify the

---

specific promotional objectives or goals of providing information, differentiating the product, increasing sales stabilizing sales, and accentuating the product's value.

- **Providing Information-** In the early days of promotional campaigns, when there was often a short supply of many items, most advertisements were designed to inform the public of a product's availability. Promotional campaigns designed to inform are often aimed at specific market segments.
- **Differentiating the Product-** Marketers often develop a promotional strategy to differentiate their goods or services from those of competitors. To accomplish this, they attempt to occupy a "position" in the market that appeals to their target customers. Promotions that apply the concept of positioning communicate to consumers meaningful distinctions about the attributes, price, quality, or usage of a good or service. Positioning is often used for goods or services that are not leaders in their field.
- **Increasing Sales-** Increasing sales volume is the most common objective of a promotional strategy. Some strategies concentrate on primary demand, others on selective demand. Sometimes specific audiences are targeted.
- **Stabilizing Sales-** Sales stabilization is another goal of promotional strategy. Sales contests are often held during slack periods. Such contests offer prizes (such as vacation trips, color televisions, and scholarships) to sales personnel who meet certain goals. Sales promotion materials—calendars, pens, and the like—are sometimes distributed to stimulate sales during off-periods. Advertising is also often used to stabilize sales. Hotels are crowded on weekdays with business travelers, but these people go home on Friday. So many hotels promote "weekend packages" at lower rates to attract tourists and vacationers
- **Accentuating the Product's Value-** Some promotional strategies are based on factors, such as warranty programs and repair services, that add to the product's value. Many Ford Motor Company advertisements promote specific car and light truck models. Some ads, however, are designed to promote Ford's 6-year, 60,000-mile powertrain warranty, while others concentrate on the Lifetime Service Guarantee offered by Ford dealers. These promotions point out greater ownership utility to buyers, thus enhancing the product's value.

Once you've identified your target market, you'll have a good idea of the best way to reach them, but most businesses use a mix of advertising, personal selling, referrals, sales promotion and public relations to promote their products or services.

- Advertising
- Selling
- Sales Promotion
- Public Relations

## 1. Advertising

### What is advertising?

Advertising is a form of communication designed to persuade potential customers to choose your product or service over that of a competitor.

Successful advertising involves making your products or services positively known by that section of the public most likely to purchase them.

It should be a planned, consistent activity that keeps the name of your business and the benefits of your products or services uppermost in the mind of the consumer.

### **Why advertise?**

The objective of advertising is to increase your profit by increasing your sales. Advertising aims to:

- Make your business and product name familiar to the public
- Create goodwill and build a favourable image
- Educate and inform the public
- Offer specific products or services
- Attract customers to find out more about your product or service

### **The rules of advertising**

There are four rules to consider when planning any advertising activity – i.e. before you prepare and book any form of advertising.

**Aim** - What is the primary purpose of the advertisement? Is it to inform, sell, produce listings or improve the image of your business?

**Target** - Who is the target? From which sector of the public are you trying to achieve a response? For example is it male, female, adult, teenager, child, mother, father etc.

**Media** – Bearing the aim and target in mind, which of the media available to you is the most suitable – i.e. TV, radio, press or Internet?

**Competitors** – What are your competitors doing? Which media channel do they use? Are they successful? Can you improve on their approach and beat them in competition?

### **Developing effective advertising**

Good advertising generally elicits the following four responses:

**Attention** – It catches the eye or ear and stands out amid the clutter of competing advertisements.

**Interest** – It arouses interest and delivers sufficient impact in the message or offering.

**Desire** – It creates a desire to learn more or crave ownership.

**Action** – It spurs an action which leads to achievement of the ad's original objective – i.e. it prompts potential customers to purchase or use your product or service.

### **Making sure your advertisement is legal**

Section 52 of the Trade Practices Act (Cth) 1974 prohibits misleading or deceptive conduct.

You must consider the advertisement as a whole and the ordinary meaning of the words used. You must determine if the people to whom the advertisement is directed are likely to be misled or deceived by its content.

You can use humour, cartoons and slogans to make your ad stand out, but be sure they're not likely to mislead or deceive your audience.

### **Commonly used media**

There are many media options open to advertisers. Which media you use will depend on who you are trying to reach, what you want to say and your budget. Often a combination of media (the media mix) can be used to good effect. Remember to keep your branding and message consistent across all media. This includes use of colours, logos, design elements and fonts.

---

- **Stationery**

Stationery, which includes letterheads, envelopes and business cards, is a means by which your business image or "name identification" is projected. Good quality stationery, used with care and attention and with a high standard of presentation, is an everyday means of presenting your business image.

- **Window display or office front**

The external presentation of your business office or shop is one of the principal ways of establishing your business image. An attractive, well maintained exterior with clear, bold sign writing is an essential start. Windows should be bright, attractively presented, scrupulously clean and well lit at night. The display should be arranged neatly and aimed at projecting an attractive company image and providing a reason to buy your products or services. Above all it should have sufficient impact to attract attention.

- **Press advertising**

This is a commonly used form of general advertising and includes advertising in all press such as newspapers, magazines and journals. Press advertising is suitable for image building, information dissemination and sales campaigns. It is also a very affordable option for small businesses.

- **Radio**

Radio is considered by many advertisers as an ideal medium due to its ability to reach specific target groups e.g. teenagers, racing followers or grocery buyers. Radio advertising covers spot adverts (usually 15 or 30 second), promotions or talkback/DJ discussions. Most radio stations offer packages which include production and extension of your radio campaign through their websites.

- **Television**

Television is a powerful advertising medium because it creates impact through sight, sound and movement however the cost of producing the advertisement and procuring sufficient air time to allow the campaign to work often makes it prohibitive for small business.

- **Direct mail**

This is a broad category covering direct communication with the consumer through email, post or fax. It can include newsletters, catalogues and letters. If you plan to use email, be sure to comply with national anti-SPAM legislation which makes it illegal to send unsolicited commercial electronic messages.

- **Outdoor**

This is any type of advertising which is done outdoors, including static advertising such as billboards, backs of street benches and bus shelters or mobile advertising displayed on buses, trains, taxis or towed signage.

- **Ambient**

Refers to any form of advertising that occurs in a non-standard medium outside the home, and usually where your consumers are likely to be. It's limited only by your imagination and includes things like advertising on the back of shopping receipts or toilet doors at the cinema, placing branded coasters at the local pub, projecting onto buildings, advertising inside lifts or distributing branded cups.

- **Cinema**

You can purchase cinema advertising by individual cinemas or screens for a set amount of screenings or "runs". Most providers offer packages which include production and screening of your advertisement.

- **Point of Sale**

Advertising at the point where the consumer makes a purchase decision e.g. floor stickers, in-store digital advertising, shopping trolley signage, shelf or counter posters or playing interviews about your product in store.

- **Online**

The options for online advertising continue to grow rapidly. They include advertising on your website, advertising on other websites, creating links to your website from other websites, publishing blogs, offering online product games, social networks and forums.

- **Directory listings**

Many consumers use business directories to find a supplier. Directories include the yellow or white pages, union directories, trade directories or local business directories.

### **Evaluating the effectiveness of your advertising**

Famous American department store merchant John Wanamaker (1838-1922) was attributed as saying "Half the money I spend on advertising is wasted – the trouble is I don't know which half." This quote is often still true today as many businesses do not evaluate the effectiveness of their advertising.

Evaluating effectiveness can be as simple as staff asking every new customer "How did you hear about us?" or asking every customer that responds to an advertised special "where did you see or hear our advertisement?"

Whatever method you use, it is absolutely critical in getting top value for your advertising money by finding out which media works and which doesn't.

## **2. Selling**

### **What is selling?**

Put simply, selling is the exchange of goods or services for an agreed sum of money.

Depending on the circumstances, a sales transaction can include one, some or all of the following stages.

**Prospecting and qualifying** – identifying qualified prospects i.e. those that are likely to want or need your product or service and can afford to pay for it.

**Pre-approach** – undertaking research about prospects to assist in the actual selling process.

**Approach** – making actual contact with the prospect in person, by phone or in writing.

**Presentation and demonstration** – presenting and demonstrating the features and benefits of your product or service in order to convince the prospect that their want or need can be satisfied.

**Handling objections** – demonstrating the product or service value to overcome real or perceived objections or misunderstandings that are impeding the purchase decision.

**Closing** – bringing the selling process to a successful conclusion by either asking for the order or responding to a positive decision from the prospect.

**Follow-up** – proactive or reactive contact with the purchaser to establish their satisfaction level and to address any problems that may exist.

In planning the selling element of your marketing strategy you will need to consider the following:

- The size and structure of your sales team
- Recruiting, training, motivating and evaluating individuals and the team as a whole

- The remuneration structure
- The location/territory to be serviced
- Management and communication systems

Selling is a particularly important element if you are marketing services because the purchaser of a professional service is in fact buying the capabilities of the seller. So he or she would be closely evaluating the behaviour and characteristics of your sales person, your business, its reputation, facilities and appearance.

### **3. Sales Promotion**

#### **What is sales promotion?**

Sales promotion relates to short term incentives or activities that encourage the purchase or sale of a product or service. Sales promotions initiatives are often referred to as “below the line” activities.

#### **What are the major sales promotion activities?**

Sales promotion activities can be targeted toward final buyers (consumer promotions), business customers (business promotions), retailers and wholesalers (trade promotions) and members of the sales force (sales force promotions). Here are some typical sales promotion activities:

#### **Consumer promotions**

- Point of purchase display material
- In-store demonstrations, samplings and celebrity appearances
- Competitions, coupons, sweepstakes and games
- On-pack offers, multi-packs and bonuses
- Loyalty reward programs

#### **Business promotions**

- Seminars and workshops
- Conference presentations
- Trade show displays
- Telemarketing and direct mail campaigns
- Newsletters
- Event sponsorship
- Capability documents

#### **Trade promotions**

- Reward incentives linked to purchases or sales
- Reseller staff incentives
- Competitions
- Corporate entertainment
- Bonus stock

#### **Sales Force Promotions**

- Commissions
- Sales competitions with prizes or awards

#### 4. Public Relations

##### What is public relations?

The Public Relations Institute of Australia (PRIA) defines Public Relations (PR) as: "The deliberate, planned and sustained effort to establish and maintain mutual understanding between an organisation (or individual) and its (or their) publics".

Put more simply, public relations is about building good relations with the stakeholders (public) of your business by obtaining favourable publicity, building a good corporate image and handling or heading off unfavourable rumours, stories and events.

By building good relationships with your stakeholders, particularly customers, you can generate positive word of mouth and referrals from satisfied customers.

##### Who is a stakeholder?

Stakeholders are the various groups in a society which can influence or pressure your business's decision making and have an impact on its marketing performance. These groups include:

- Clients/customers
- Staff
- Shareholders
- Strategic partners
- Media
- Government
- Local community
- Financial institutions
- Community groups

Operationally, stakeholders really refer to those groups that your business is or should be, communicating with.

##### What are the main public relations tools?

Typical PR tools include:

- News creation and distribution (media releases)
- Special events such as news conferences, grand openings and product launches
- Speeches and presentations
- Educational programs
- Annual reports, brochures, newsletters, magazines and AV presentations
- Community activities and sponsorships

##### What are the key steps in implementing public relations?

Implementing effective public relations activities requires careful planning. The three major steps are outlined below

**Setting the objectives** – what is it you want to achieve and who do you want to reach? Is it to create awareness of a new product or service to your existing clients, to overcome community misconceptions about your business or to create a positive impression with your bank manager?

**Deciding on the message and the vehicle** – what is the major thing you want to communicate and what public relations tools will you use to get the message to its target?

**Evaluating the results** – did you achieve the desired result and did it lead to a positive outcome?

Many small businesses do not devote enough attention to public relations in their promotional mix but done properly, it can be a powerful and cost effective business development and marketing tool.

### Promotion through the Product life cycle

As products move through the four stages of the product lifecycle different promotional strategies should be employed at these stages to ensure the healthy success and life of the product .

### Stages and promotion strategies employed.

#### Introduction

When a product is new, the organisations objective will be to inform the target audience of its entry. Television, radio, magazine, coupons etc may be used to push the product through the introduction stage of the lifecycle. Push and Pull Strategies will be used at this crucial stage.

#### Growth

As the product becomes accepted by the target market the organisation at this stage of the lifecycle the organisation works on the strategy of further increasing brand awareness to encourage loyalty.

#### Maturity

At this stage with increased competition the organisation take persuasive tactics to encourage the consumers to purchase their product over their rivals. Any differential advantage will be clearly communicated to the target audience to inform of their benefit over their competitors.

#### Decline

As the product reaches the decline stage the organisation will use the strategy of reminding people of the product to slow the inevitable.

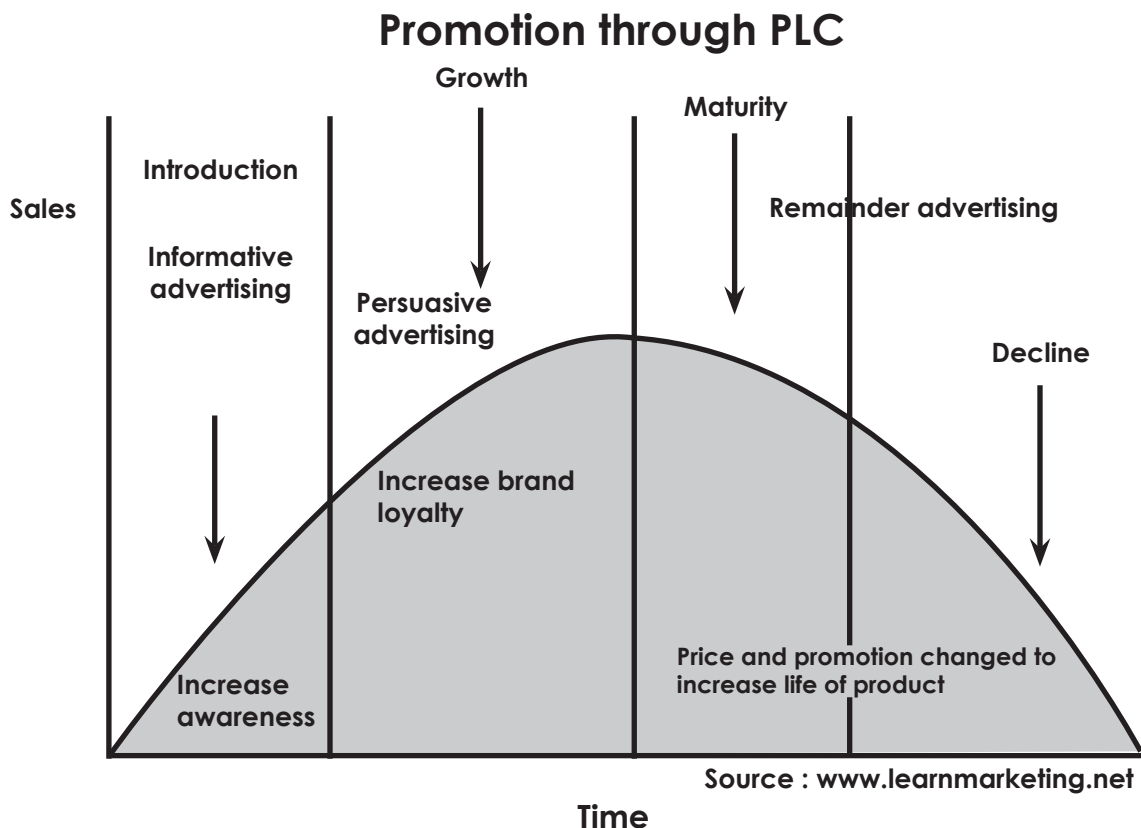



### **Internet Promotion**

The development of the world wide web has changed the business environment forever. Dot com fever has taken the industry and stock markets by storm. The e-commerce revolution promises to deliver a more efficient way of conducting business. Shoppers can now purchase from the comfort of their home 24 hours a day 7 days a week.

Owning a website is now a crucial ingredient to the marketing mix strategy of an organisation. Consumers can now obtain instant information on products or services to aid them in their crucial purchase decision. Sony Japan took pre-orders of their popular Playstaion 2 console over the net, which topped a 1 million after a few days, European football stars are now issuing press releases over the web with the sites registered under their own names. Hit rates are phenomenal.

Advertisers have now moved their money over to the internet as customers are on average spending more time online then watching TV. Popular ways to advertise seem to be with banners and pop ups.

### **Branding**

Coca-cola is the most valuable brand in the world, with the name alone worth billions of dollars. But why? What is a brand?

Brand management is a total approach to managing brands that is sometimes extended, by those who understand the power of brands, to cover the whole approach to managing the company.

#### **A brand is a promise**

First and foremost, a brand is a promise. It says 'you know the name, you can trust the promise'. As all promises, it is trusted only as far as those promises are met. Trust is a critical first step and brands aim to accelerate that step by leveraging the implied promise of the brand.

#### **A brand is an associated image**

Most brands have a logo which acts as a short-cut to remind us of the brand promise. The logo uses color, shape, letters and images to create a distinctive image that is designed both to catch our eye and to guide our thoughts in the right direction. The brand may also be associated with tunes, celebrities, catchphrases and so on.

All parts of the brand image works as a psychological trigger or stimulus that causes an association to all other thoughts we have about the brand.

#### **Everything and everyone is a brand**

If you get down to the detail, everything is a brand, because we build our understanding of the world by creating associations about everything. A tree has an implied promise of beauty and shade. Even words are brands. When I say 'speed', you will conjure up images of fast cars, etc.

People are brands, too. When people see you, or even hear your name, they will recall the image they have of you, (which is something you can actively manage or 'let happen'). In a company where people are visible to customers, such as a service business, the people are very much a part the brand.

The American Marketing Association (AMA) defines a brand as a "name, term, sign, symbol or design, or a combination of them intended to identify the goods and services of one seller or group of sellers and to differentiate them from those of other sellers.

Therefore it makes sense to understand that branding is not about getting your target market to choose you over the competition, but it is about getting your prospects to see you as the only one that provides a solution to their problem.

The objectives that a good brand will achieve include:

- Delivers the message clearly
- Confirms your credibility

- Connects your target prospects emotionally
- Motivates the buyer
- Concretes User Loyalty

To succeed in branding you must understand the needs and wants of your customers and prospects. You do this by integrating your brand strategies through your company at every point of public contact.

Your brand resides within the hearts and minds of customers, clients, and prospects. It is the sum total of their experiences and perceptions, some of which you can influence, and some that you cannot.

A strong brand is invaluable as the battle for customers intensifies day by day. It's important to spend time investing in researching, defining, and building your brand. After all your brand is the source of a promise to your consumer. It's a foundational piece in your marketing communication and one you do not want to be without.



Branding is a process, a tool, a strategy and an orientation.

- Branding is the process by which a marketer tries to build long term relationship with the customers by learning their needs and wants so that the offering (brand) could satisfy their mutual aspirations.
- Branding can be viewed as a tool to position a product or a service with a consistent image of quality and value for money to ensure the development of a recurring preference by the consumer.
- Branding is used as a differentiation strategy when the product cannot be easily distinguished in terms of tangible dimensions (which invariably happen in case of many non-durables, services and even durables) or in products which are perceived as a commodity (e.g. cement, fertilizer, salt, potato chips etc.).
- Brand building is a conscious customer-satisfaction orientation process. The brand owner tries to retain customers to its fold by a mix of hardware and software because when a customer feels satisfied he/she develops a kind of loyalty for the same.

### Benefits of Branding

Brands are so numerous and common- place today that we are inclined to take their significance for granted.

Branding refers to the use of a name, a term, a symbol or a design to identify goods or services of a seller and to distinguish them from those of other sellers. A good brand name can make a big difference in your success. Your brand name may be the single most important decision you can make about your company, product or service name. Branding is advantageous because it ...

**1. Creates an Image or Personality.** A brand name can project an expectation of its performance and an emotion or feeling about it.

**2. May Help Segment Markets.** Virtually identical products could be sold in different distribution channels under different brand names and positioning.

**3. Makes Purchasing Easier.** After making a satisfactory brand decision for the first time, customers are likely to make repeat purchases without major reconsideration. Therefore, a good brand speeds up shopping.

**4. May Develop a Customer Franchise.** Achieving brand loyalty among your customers will protect you from competition and give you greater control over your marketing mix.

Brand name selection is still an art, but there are a number of general rules that should be observed. Your brand should help communicate something important about your product or service – like its core concept or reason for being. It should be short, memorable, pronounceable and distinguishable from competition. If you are involved in exporting, you need to be concerned with its foreign meaning (many firms have been embarrassed on this one).

Once you have a great brand name, branding can make your promotion more effective and efficient. Persistent promotion of your brand can create various levels of Brand Familiarity such as brand recognition, preference, insistence or advocacy.

**Brand Recognition** is when target customers remember having seen or heard of the brand. This is critically important, basic prospect education for new companies, products or services.

**Brand Preference** is when target customers will choose the brand out of habit or past experience. If your customers are satisfied with the products or services, they will buy your brand again if available.

**Brand Insistence** is when target customers insist upon a product and would be willing to search extensively for it. Your customer is so satisfied that your competitors don't have a chance to take the business away from you (competitive insulation).

**Brand Advocacy** is when the satisfied customer tells everyone whom they know how great your product or service is. They become your best salesperson.

### Types of brand

#### Product

The most common brand is that associated with a tangible product, such as a car or drink. This can be very specific or may indicate a range of products. In any case, there is always a unifying element that is the 'brand' being referred to in the given case.

#### Individual product

Product brands can be very specific, indicating a single product, such as classic Coca-Cola. It can also include particular physical forms, such as Coca-Cola in a traditional bottle or a can.

#### Product range

Product brands can also be associated with a range, such as the Mercedes S-class cars or all varieties of Colgate toothpaste.

#### Service

As companies move from manufacturing products to delivering complete solutions and intangible services, the brand is about the 'service'.

---

Service brands are about what is done, when it is done, who does it, etc. It is much more variable than products brands, where variation can be eliminated on the production line. Even in companies such as McDonald's where the service has been standardized down to the eye contact and smile, variation still occurs.

Consistency can be a problem in service: we expect some variation, and the same smile every time can turn into an annoyance as we feel we are being manipulated. Service brands need a lot more understanding than product brands.

### **Organization**

Organizations are brands, whether it is a company that delivers products and services or some other group. Thus Greenpeace, Mercedes and the US Senate are all defined organizations and each have qualities associated with them that constitute the brand.

In one sense, the brand of the organization is created as the sum of its products and services. After all, this is all we can see and experience of the organization. Looking at it another way, the flow also goes the other way: the intent of the managers of the organization permeates downwards into the products and the services which project a common element of that intent.

### **Person**

The person brand is focused on one or a few individuals, where the branding is associated with personality.

### **Individual**

A pure individual brand is based on one person, such as celebrity actor or singer. The brand can be their natural person or a carefully crafted projection.

Politicians work hard to project a brand that is attractive to their electorate (and also work hard to keep their skeletons firmly in the cupboard). In a similar way, rock stars who want to appear cool also are playing to a stereotype.

### **Group**

Not much higher in detail than an individual is the brand of a group. In particular when this is a small group and the individuals are known, the group brand and the individual brand overlap, for example in the way that the brand of a pop group and the brand of its known members are strongly connected.

Organizations can also be linked closely with the brand of an individual, for example Virgin is closely linked with Richard Branson.

### **Event**

Events have brands too, whether they are rock concerts, the Olympics, a space-rocket launch or a town-hall dance.

Event brands are strongly connected with the experience of the people attending, for example with musical pleasure or amazement at human feats.

Product, service and other brands realize the power of event brands and seek to have their brands associated with the event brands. Thus sponsorship of events is now big business as one brand tries to get leverage from the essence of the event, such as excitement and danger of car racing.

### **Geography**

Areas of the world also have essential qualities that are seen as characterizations, and hence also have brand. These areas can range from countries to state to cities to streets and buildings.

Those who govern or represent these geographies will work hard to develop the brand. Cities, for example, may have de-facto brands of being dangerous or safe, cultural or bland, which will be used

by potential tourists in their decisions to visit and by companies in their decisions on where to set up places of employment.

### **Brand Equity**

Brand equity is the added value endowed on products and services. It may be reflected in the way consumers think, feel, and act with respect to the brand, as well as in the prices, market share, and profitability the brand commands for the firm.

Marketers and researchers use various perspectives to study brand equity. Consumer based approaches view it from the perspective of the consumer – either an individual or an organization. The premise of customer – based brand equity models is that the power of a brand lies in what customers have seen, read, heard, learned, thought, and felt about the brand over time.

Customer-based brand equity is the differential effect that brand knowledge has on consumer response to the marketing of that brand. A brand has positive customer-based brand equity when consumers react more favourably to a product and the way it is marketed when the brand is identified, than when it is not identified. A brand has negative customer-based brand equity if consumers react less favourably to marketing activity for the brand under the same circumstances.

### **Coca Cola Branding Strategy**

#### **Introduction:**

Coca-Cola is a carbonated soft drink sold in stores, restaurants and vending machines internationally. The Coca-Cola Company claims that the beverage is sold in more than 200 countries. It is produced by The Coca-Cola Company in Atlanta, Georgia, and is often referred to simply as Coke or (in European and American countries) as cola, pop, or in some parts of the U.S., soda. Originally intended as a patent medicine when it was invented in the late 19th century by John Pemberton, Coca-Cola was bought out by businessman Asa Griggs Candler, whose marketing tactics led Coke to its dominance of the world soft-drink market throughout the 20th century. The company produces concentrate, which is then sold to licensed Coca-Cola bottlers throughout the world.

The Coca-Cola Company has, on occasion, introduced other cola drinks under the Coke brand name. The most common of these is Diet Coke, with others including Caffeine-Free Coca-Cola, Diet Coke Caffeine-Free, Coca-Cola Cherry, Coca-Cola Zero, Coca-Cola Vanilla, and special editions with lemon, lime or coffee.

#### **Brand building strategy :**

Brand development strategy of Coca Cola has been far reaching and has managed to remain in the limelight ever since it became a favorite with the non alcoholic drinkers. It has been noticed that brand loyalty is an important factor in maintaining the number one position. Founded in the year 1886, the Coca Cola company enjoys the status of being one of the biggest non alcoholic beverage companies of the world. It has a distribution system, which makes it unique from the rest of the non alcoholic beverage manufacturers. Over the years, Coca Cola has passed several tests of brand enhancement and the company makes it a point that the products under the banner Coca Cola continue to invade the minds of the consumers. The brand development strategy of Coca Cola comprised redesigning of its brand development policies and techniques to keep up with the changing mindset of its consumers. Earlier, this brand believed in the following:

- Afford ability
- Availability
- Acceptability

---

However, this brand development strategy of Coca Cola was re worked to stress on the following instead:

- Price value
- Preference
- “Pervasive penetration”.

The essence of brand building of the company lies in the fact that it wants its consumers accessibility to be “within an arm’s reach of desire”. In an attempt to build its brand identity, as many as 20 brand attributes are tested every month involving as many as 4000 customers. The brand development strategy of Coca Cola is effective as it has been able to construct, manage as well as maintain its brand image. Another reason why this brand has gained unanimous acceptance all around the globe is due to the fact that it has been able to connect very well with its consumers. This implies brand loyalty. Brand loyalty has been instrumental in keeping up the brand image of Coca Cola. It believes in shelling out the best so that the consumers are retained by default. A part of the brand building technique is also to enhance “purchase frequency”. The company has also invested in various advertisement campaigns often engaging the services of celebrities around the globe. In addition to the consumers, there is another category of consumers, who increase the consumer base and they constitute the collectors of the brand. The collectors usually indulge in collecting old as well as upcoming logos of Coca Cola, bottles and literary matter. With regard to the brand development of Coca Cola Zero, the company came out with an advertisement, which was quite different from the conventional ones. In this regard, (no calorie beverage), it has shelled out three types of products.

- Coca Cola Classic
- Diet Coke
- Coca Cola Zero.

There are few experts who believe that when Coca Cola had the tag line of “The Real Thing”, it was really that but with the invention of various categories of coke, the “real thing” changes to “many things”, and the original flavor is usually lost. Hence, the brand building strategies should be such that it does not confuse people and is able to retain consumers despite the fact that several new non alcoholic beverage firms are on the anvil.

### **The Power of Brand Accessibility**

If you were another soft drink company, you might define your competitive frame of reference as the cola market or the soft drink market or even the beverage market. But Coke thinks of its business and its market share in terms of “share of human liquid consumption.” This makes water a competitor. In fact, a Coke executive has said that he won’t be satisfied until “there is a Coca-Cola faucet in every home.” Coca-Cola’s mantra is “within an arm’s reach of desire.”

### **One Final Coca-Cola Fact**

A recent Coca-Cola annual report reported that the second most recognized expression in the world after “ok?” is “Coca-Cola.”

### **Distribution Strategies**

In business, distribution strategies are the process of making a company’s product or service available to consumers either directly, through means such as an online website, an actual storefront, or the dreaded telemarketer, or indirectly, through multiple resellers.

Important to the process are channels and intermediaries. Intermediaries are organizations and individuals that are involved with making the product or service available for consumer consumption. Channels are sets of these intermediaries, classified by how many there are between the producer and the consumer of a particular good or service. Oftentimes, most organizations will use a mix of several different channels, so that they can reach a larger potential consumer base.

There are three different types of distribution strategies, a progression that depends on how many intermediaries are used.

**Different Distribution Strategies:**

**1. Intensive Distribution**

A distribution strategy that sees a business's product sold in as many outlets as possible; it is used primarily for goods that are appeal to a broad range of consumers, such as basic supplies, magazines, and snack foods.

**2. Selective Distribution**

This distribution method relies on fewer intermediaries, while still maintaining a respectable amount, and is used primarily for more specialized goods, such as automobiles and computers.

**3. Exclusive Distribution**

A strategy wherein a business selects a limited few intermediaries as partners; oftentimes these intermediaries will sell only that business's products to the exclusion of everything else. This distribution strategy is typical of high end, luxury products, like sports cars and designer clothes.

Channels of distribution

**Channels of Distribution**

Distribution options include:

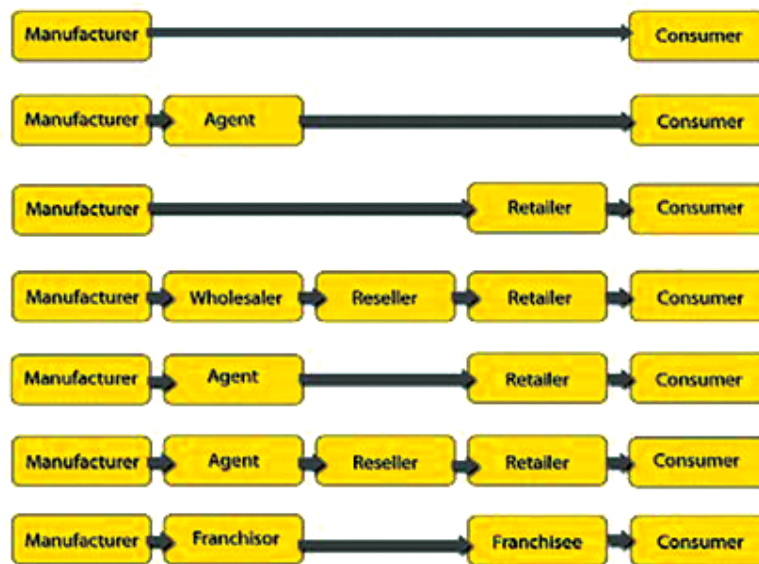

In some instances, multiple channels may be used. For example, a manufacturer may:

- sell to a wholesaler
- have a website or shop selling "factory direct" to the public
- have representatives selling "party plan" to the public
- have agents or distributors selling in other territories

# Study Note - 6

## FINANCIAL AND NON-FINANCIAL PERFORMANCE INDICATORS AND PROFITABILITY



This Study Note includes

**6.1 Key Indicators for measuring Financial Performance and Non-Financial Performance**

**6.2 Methods for Improvement of Productivity and Profitability**

**6.3 Balanced Score Card**

### 6.1 KEY INDICATORS FOR MEASURING FINANCIAL PERFORMANCE AND NON-FINANCIAL PERFORMANCE

Key performance indicators are financial and non financial indicators that organizations use in order to estimate and fortify how successful they are, aiming previously established long lasting goals. Appropriate selection of indicators that will be used for measuring is of greatest importance.

Process organization of business is necessary to be constituted in order to realize such effective and efficient system or performance measuring via KPI. Process organization also implies customer orientation and necessary flexibility which is important in present scenario of global competition.

New business conditions where information is the most important resource impose new approaches in measuring performances of organizations, related to traditional performance measurement system which evolved as just financial and accounting indicators.

KPI are financial and non- financial measures that organizations use to reveal how successful they were in accomplishing long lasting goals.

Key performance indicators (KPI) are financial and non-financial indicators that organization uses to testify how successful they were in achieving of long lasting goals. KPI are static and stable indicators that carry more meaning when comparing information. They help to remove the emotion away from object of the business, and get one focused on the thing that job is really about, and that is making profit.

#### 6.1.1 Financial Performance Indicators

It is very important to monitor a wide range of 'performance indicators' in your business, in order to ensure that appropriate and timely decisions and plans can be made. Given that sales, profit margins and cash flow are the lifeblood of any business, owners should place particular emphasis on receiving regular reports on these areas of the business.

Knowing the financial position becomes even more important as the business grows, especially if your plan is to grow the business substantially. Lack of a precise and timely knowledge of the current financial position can lead to business failure and have other consequences for the directors/owners.

All organisations have financial performance measures as part of their performance management, although there is debate as to the relative importance of financial and non-financial indicators.

#### 6.1.2 Financial Statements

The minimum financial information for any business should be periodic financial statements consisting of at least a balance sheet and profit and loss statement.

Businesses that provide credit to customers also need to control their debtors through monthly aged debtors trial balances. Those who have a significant investment in stock should control that through perpetual inventory records. Regular debtor and inventory reports will help prevent too much capital



being tied up in these areas and allows for prompt follow up action. For example, changing inventory ordering patterns and allowing immediate follow up on debtors to prevent bad debts.

One disadvantage of financial statements is that they show the results of the business after the event and as such they are a lag indicator.

If prepared solely on an annual basis (and often this happens well after the end of the year) there is a considerable lag. More frequent reporting periods are needed for more important data as well as use of other financial and non-financial indicators are also important. Examples are number of enquiries, number of customers per day, average sales value, number of quoted jobs lost, customer satisfaction and so on.

Thus for best results, financial statements and other key performance indicators (KPIs) should be prepared on a regular and consistent basis and compared with prior periods. Monitoring performance using successive monthly or quarterly accounts can show trends that otherwise might not be apparent.

### 6.1.3 The following are some important KPIs that should be monitored:

- **Stock turnover – days.** Reflects the number of days that it takes to sell inventory. The lower the ratio means the quicker the stock is sold.
- **Debtors turnover – days.** Reflects average length of time from sale to cash collection. The lower the ratio means the quicker the accounts are paid. From a cash flow perspective, it is important to keep days outstanding to a minimum.
- **Current ratio.** Indicates the extent to which current assets cover current liabilities and is a measure of the ability to meet short-term obligations. The rough rule of thumb is a ratio of 2:1. That is for every ₹1 of liabilities (within 12 months), there should be at least ₹2 in current assets to meet such liabilities.
- **Debt/equity.** This is a measure of the extent to which a business relies on external borrowings to fund its on-going operations. The higher the ratio, the more heavily the debt financing is used. In order to provide a reliable measure, assets should be valued at market value.
- **Interest coverage.** Provides a measure of the ability of the business to meet its interest commitments out of profits and is linked to the debt/equity ratio. The rough rule of thumb used by banks is a ratio of 3:1. That is, operating profit before income tax exceeding interest expense three times.
- **Return on investment.** Represents the after-tax return that owners are receiving on their investment and should be compared with alternative forms of investment.
- **Gross profit margin.** An indication of the profitability of the business and reflects control over cost of sales and pricing policies. This ratio should be compared with prior periods and to any available industry data.
- **Breakeven sales.** Reflects the sales that need to be generated in order to cover expenses. In other words, this is the level of activity at which neither a profit nor loss is incurred, or where total costs equate with total revenue. This is a very important ratio that every owner should monitor on a monthly basis.

### 6.1.4 Profit and loss and cash flow budgets

Business owners should also prepare monthly profit and loss budgets for at least a 12-month period and more importantly to assess the impact that these projections have on the future cash flow of the business. Budgets should be compared to actual results and variances acted upon on a timely basis.

For more accurate reporting, particularly in respect of manufacturers, wholesalers and retailers, it is preferable that the profit and loss and cash flow budgets are linked and have a number of in-built features including:

- (i) The profit and loss budget should have columns that separate income and expenses including GST or excluding GST.

Note - the amounts in the profit and loss budget are recorded on a GST-exclusive basis, whereas on the cash flow budget, they appear on a GST-inclusive basis.

- (ii) The cash flow budget should automatically calculate GST owed to the ATO depending on whether the business is using either monthly or quarterly GST reporting and whether GST is paid on either cash or accruals basis.
- (iii) It is common for operating expenses on the profit and loss budget to be amortised evenly during the 12-month period and the cash flow budget records these payments on either monthly or quarterly basis. For example rates and taxes, insurance, light and power, and fringe benefits tax are usually paid quarterly, whilst all other operating expenses are usually paid monthly.
- (iv) By entering an interest rate, the profit and loss budget should have the facility to calculate interest paid each month on the overdraft, or interest received where the account is in credit at the end of the month.
- (v) Opening balances (for example, bank overdraft/credit balance, GST liability/refund, debtors and creditors) need to be recorded on the cash flow budget.
- (vi) The collection and payment percentage rates for debtors and creditors (for example, current, 30 days, etc.) should be recorded to better reflect the impact of sales and purchases on the cash flow budget.

The cash flow budget should include common items such as PAYG installments/income tax, loan repayments, plant & equipment purchases, dividends, and loans made to the business.

### 6.1.5 The objectives of profit-seeking organisations

Proponents of financial performance measures argue that they are necessary because of the primary objectives of companies.

#### Maximising shareholder wealth

- The primary objective of a profit seeking organisation is to maximise shareholder wealth.
- This is based on the argument that shareholders are the legal owners of a company and so their interests should be prioritised.
- Shareholders are generally concerned with the following:
  - current earnings
  - future earnings
  - dividend policy
  - relative risk of their investment.

All of these are driven by financial performance.

#### Survival and growth

The objective of wealth maximisation is usually expanded into three sub-objectives:

- to make a **profit** (see above)
- to continue in existence (**survival**) - survival is the ultimate measure of success of a business. Without survival obviously there will be no fulfillment of other objectives. In order to survive in the long-term a business must be financially successful.
- to maintain **growth** and development - growth is generally seen as a sign of success, provided it results in improvements in financial performance.

Growth can be identified in a number of ways both financial and non-financial.

**Financial:**

- profitability
- revenue
- return on investment (ROI)
- cash flow.

**Non-financial:**

- market share
- number of employees
- number of products.

**6.1.6 The relationship between profits and shareholder value**

Rather than focusing on achieving higher profit levels, companies are under increasing pressure to look at the long-term value of the business. This is due to the following factors.

- research has suggested a poor correlation between shareholder return and profits
- investors are increasingly looking at long-term value
- reported profits may not be comparable between companies.

While these issues have been known for some time, they have come into sharp focus due to the performance of new age companies.

**6.1.7 Shareholder return and profits**

Total shareholder return (TSR) is the return shareholders receive both in dividends and capital growth.

Studies have found that there is little correlation between TSR and EPS growth, and virtually no relationship at all with return on equity, yet many companies are still using profit as their only measure of performance.

Even where companies state that their objective is to maximise shareholder value, often directors' bonuses are still based on short-term profitability or EPS targets.

However strong evidence of co-relation has been found between shareholder value and future cash flows, another financial measure.

**6.1.8 Traditional financial performance measures**

Financial performance exists at different levels of the organisation.

Traditionally, financial performance measures are split into the following categories:

- Profitability
- Liquidity / working capital
- Gearing
- Investor ratios

**Profitability measures**

**Return on capital employed (ROCE)**

**ROCE** is a key measure of profitability. It shows the net profit that is generated from every ₹1 of assets employed.



$$\text{ROCE} = \frac{\text{Net profit}}{\text{Capital employed}} \times 100$$

- ROCE is sometimes calculated using PBIT instead of net profit. Use whichever figure is given in the exam.
- Capital employed = Total Assets less Current Liabilities or total equity plus long-term debt.
- Capital employed may be based on net book value (NBV), gross book value or replacement cost. (note to students: Use whichever figure is given in the exam.)

Advantages	Disadvantages
<ul style="list-style-type: none"><li>• Easy to calculate.</li><li>• Figures are readily available.</li><li>• Measures how well a business is utilising the funds invested in it.</li><li>• Often used by external analysts/investors.</li></ul>	<ul style="list-style-type: none"><li>• Research shows a poor correlation between ROCE and shareholder value.</li><li>• Care must be taken to ensure that like is compared with like, when comparing with different companies – e.g. inclusion of intangibles in capital employed.</li><li>• Can be distorted by accounting policies.</li><li>• ROCE can be improved by cutting back investment – this may not be in the company's long-term best interest.</li></ul>

#### **An increase in ROCE could be achieved by:**

- Increasing net profit, e.g. through an increase in sales price or through better control of costs.
- Reducing capital employed, e.g. through the repayment of long term debt.

The ROCE can be understood further by calculating the net profit margin and the asset turnover:

$$\text{ROCE} = \text{Net Profit Margin} \times \text{Asset Turnover}$$

#### **Gross profit margin**

This is the gross profit as a percentage of turnover.

$$\text{Gross profit margin} = \frac{\text{Gross profit}}{\text{Turnover}} \times 100$$

A high gross profit margin is desirable. It indicates that either sales prices are high or production costs are being kept well under control.

#### **Net profit margin**

This is the net profit (turnover less all expenses) as a percentage of turnover.

$$\text{Net profit margin} = \frac{\text{Net profit}}{\text{Turnover}} \times 100$$

A high net profit margin is desirable. It indicates that either sales prices are high or all costs are being kept well under control.

#### **Asset turnover**

This is the turnover divided by the capital employed. The asset turnover shows the turnover that is generated from each ₹1 of assets employed.

$$\text{Asset turnover} = \frac{\text{Turnover}}{\text{Capital employed}}$$

A high asset turnover is desirable. An increase in the asset turnover could be achieved by:

- Increasing turnover, e.g. through the launch of new products or a successful advertising campaign.
- Reducing capital employed, e.g. through the repayment of long term debt.

**EBITDA (Earnings before interest, tax and depreciation adjustment)**

**EBITDA** is:

- earnings before interest, tax and depreciation adjustment or
- earnings before interest, tax, depreciation and amortisation.

The two versions are entirely interchangeable.

Advantages	Disadvantages
<ul style="list-style-type: none"> <li>• It is a proxy for cash flow from operations and is therefore a measure of underlying performance.</li> <li>• Tax and interest are externally generated and therefore not relevant to the underlying success of the business.</li> <li>• Depreciation and amortisation represent a write off of expenditure over a number of years and might therefore be excluded when examining the performance of a particular year.</li> <li>• Easy to calculate.</li> <li>• Easy to understand.</li> </ul>	<ul style="list-style-type: none"> <li>• It ignores changes in working capital and their impact on cash flow.</li> <li>• It fails to consider the amount of fixed asset replacement needed by the business.</li> <li>• It can easily be manipulated by aggressive accounting policies related to income recognition and capitalisation of expenses.</li> </ul>

**Liquidity measures**

The main reason why companies fail is poor cash management rather than profitability so it is vital that liquidity is managed.

A company can be profitable but at the same time encounter cash flow problems. Liquidity and working capital ratios give some indication of the company's liquidity.

**Current ratio**

This is the current assets divided by the current liabilities.

$$\text{Current ratio} = \frac{\text{Current assets}}{\text{Current liabilities}}$$

The ratio measures the company's ability to meet its short term liabilities as they fall due. A ratio in excess of 1 is desirable but the expected ratio varies between the type of industry. A decrease in the ratio year on year or a figure that is below the industry average could indicate that the company has liquidity problems. The company should take steps to improve liquidity, e.g. by paying creditors as they fall due or by better management of receivables in order to reduce the level of bad debts.

**Quick ratio (acid test)**

This is similar to the current ratio but inventory is removed from the current assets due to its poor liquidity in the short term.

$$\text{Current ratio} = \frac{\text{Current assets} - \text{inventory}}{\text{Current liabilities}}$$

The comments are the same as for the current ratio.

### **Inventory holding period**

$$\text{Inventory holding period} = \frac{\text{Inventory}}{\text{Cost of sales}} \times 365$$

This indicates the average number of days that inventory items are held for.

An increase in the inventory holding period could indicate that the company is having problems selling its products and could also indicate that there is an increased level of obsolete stock. The company should take steps to increase stock turnover, e.g. by removing any slow moving or unpopular items of stock and by getting rid of any obsolete stock.

A decrease in the inventory holding period could indicate that the company's ability to turn over inventory has improved and the company does not have excess cash tied up in inventory. However, any reductions should be reviewed further as the company may be struggling to manage its liquidity and may not have the cash available to hold the optimum level of inventory.

### **Receivables (debtor) collection period**

$$\text{Receivables collection period} = \frac{\text{Receivables}}{\text{Turnover}} \times 365$$

This is the average period it takes for a company's credit customers / debtors / receivables to pay what they owe.

An increase in the receivables collection period could indicate that the company is struggling to manage its debts. Possible steps to reduce the ratio include:

- Credit checks on customers to ensure that they will pay on time
- Improved credit control, e.g. invoicing on time, chasing up bad debts.

A decrease in the receivables collection period may indicate that the company's has improved its management of receivables. However, a receivables collection period well below the industry average may make the company uncompetitive and profitability could be impacted as a result.

### **Payables (creditor) period**

$$\text{Payables period} = \frac{\text{Payables}}{\text{Purchases}} \times 365$$

This is the average period it takes for a company to pay for its purchases.

An increase in the company's payables period could indicate that the company is struggling to pay its debts as they fall due. However, it could simply indicate that the company is taking better advantage of any credit period offered to them.

A decrease in the company's payables period could indicate that the company's ability to pay for its purchases on time is improving. However, the company should not pay for its purchases too early since supplier credit is a useful source of finance.

### **Gearing ratios**

In addition to managing profitability and liquidity it is also important for a company to manage its financial risk. The following ratios may be calculated:

#### **Financial gearing**

This is the long term debt as a percentage of equity.

$$\text{Gearing} = \frac{\text{debt}}{\text{equity}} \times 100$$

$$\text{or} = \frac{\text{debt}}{\text{equity}} \times 100$$

A high level of gearing indicates that the company relies heavily on debt to finance its long term needs. This increases the level of risk for the business since interest and capital repayments must be made on debt, where as there is no obligation to make payments to equity.

The ratio could be improved by reducing the level of long term debt and raising long term finance using equity.

**Interest cover**

This is the operating profit (profit before finance charges and tax) divided by the finance cost.

$$\text{Interest cover} = \frac{\text{operating profit}}{\text{finance cost}}$$

A decrease in the interest cover indicates that the company is facing an increased risk of not being able to meet its finance payments as they fall due.

The ratio could be improved by taking steps to increase the operating profit, e.g. through better management of costs, or by reducing finance costs through reducing the level of debt.

**Other investor ratios**

Investors will be interested in all of the above measures, along with the following:

**Earnings Per Share (EPS)**

**EPS** is a measure of the profit attributable to each ordinary share.

$$\text{EPS} = \frac{\text{Profit after tax less preference dividends}}{\text{Weighted average number of ordinary shares in issue}}$$

For EPS to be truly meaningful, it must be set in context.

- Is EPS growing or declining over time?
- Is there likely to be significant dilution of EPS?
- Is it calculated consistently?

Advantages	Disadvantages
<ul style="list-style-type: none"> <li>• Easily understood by shareholders.</li> <li>• Calculation is precisely defined in FRS 22 (IAS 33) avoiding ambiguity.</li> <li>• Figures are readily available.</li> <li>• Often used as a performance measure between companies, sectors, periods within the same organisation.</li> </ul>	<ul style="list-style-type: none"> <li>• Research shows a poor correlation between EPS growth and shareholder value.</li> <li>• Accounting treatment may cause ratios to be distorted.</li> </ul>

**Dividend cover**

This is the net profit divided by the dividend.

$$\text{Dividend cover} = \frac{\text{net profit}}{\text{dividend}} \times 100$$



A decrease in the dividend cover indicates that the company is facing an increased risk of not being able to make its dividend payments to shareholders.

### **Dividend yield**

- Dividend yield = (Dividend per share/Current share price) × 100%

This is one way of measuring the return to shareholders but ignores any capital growth / loss.

### **Earnings yield**

- Earnings yield = (EPS/Share price) × 100%

This is another way of measuring the return to shareholders but, as with dividend yield, ignores any capital growth / loss.

## **6.1.9 Non-Financial Performance Indicators (NFPs)**

As part of performance management, organisations will use a mixture of financial performance indicators and non-financial ones.

### **The drawbacks of sole reliance on financial performance measures**

There are a number of problems associated with the exclusive use of financial performance indicators to monitor performance:

#### **Short-termism**

Linking rewards to financial performance may tempt managers to make decisions that will improve short-term financial performance but may have a negative impact on long-term profitability.

For example, a manager may decide to delay investment in order to boost the short-term profits of their division.

#### **Internal focus**

Financial performance measures tend to have an internal focus. In order to compete successfully it is important that external factors (such as customer satisfaction and competitors' actions) are also considered.

#### **Manipulation of results**

In order to achieve target financial performance (and hence their reward), managers may be tempted to manipulate results.

For example, costs recorded in the current year may be wrongly recorded in the next year's accounts in order to improve current year performance.

#### **Do not convey the whole picture**

The use of financial performance indicators has limited benefit to the company since they do not convey the full picture regarding the factors that drive long-term success and maximisation of shareholder wealth, e.g. customer satisfaction, ability to innovate, quality.

Put differently, financial performance is often a consequence of changes in non-financial factors. In particular, many critical success factors involve non-financial factors.

#### **Backward looking**

Financial performance measures are traditionally backward looking. This is not suitable in today's dynamic business environment.

The solution is to use both financial and non-financial performance indicators

The optimum system for performance measurement and control will include:



- Financial performance indicators (FPIs) - it is still important to monitor financial performance, e.g. using ROCE, EBITDA, EVA.
- Non-financial performance indicators (NFPIs) - these measures will reflect the long-term viability and health of the organisation

### **6.1.10 NFPIs and business performance**

Choosing performance measures is a challenge. Performance measurement systems play a key role in developing strategy, evaluating the achievement of organizational objectives and compensating managers. Yet many managers feel traditional financially oriented systems no longer work adequately. A recent survey of U.S. financial services companies found most were not satisfied with their measurement systems. They believed there was too much emphasis on financial measures such as earnings and accounting returns and little emphasis on drivers of value such as customer and employee satisfaction, innovation and quality.

In response, companies are implementing new performance measurement systems. A third of financial services companies, for example, made a major change in their performance measurement system during the past two years and 39% plan a major change within two years.

There are a number of areas that are particularly important for ensuring the success of a business and where the use of NFPIs plays a key role. These include:

- the management of human resources
- product and service quality
- brand awareness and company profile.

#### **The management of human resources**

Traditionally the main performance measure for staff was cost (a FPI). However, businesses have started to view staff as a major asset and recognise that it is important to attract, motivate and retain highly qualified and experienced staff.

As a result, NFPIs are now also used to monitor and control staff. These can include the following:

- staff turnover
- absentee rates / sick days
- % of job offers accepted
- results of job satisfaction surveys
- competence surveys

#### **Product and service quality**

Problems with product or service quality can have a long-term impact on the business and they can lead to customer dissatisfaction and loss of future sales.

A product (or service) and its components should be critically and objectively compared both with competition and with customer expectation and needs, for example:

- Is it good value?
- Can it really deliver superior performance?
- How does it compare with competitor offerings?
- How will it compare with competitor offerings in the future given competitive innovations?

Product and service quality are usually based on several critical dimensions that should be identified and measured over time. Performance on all these dimensions needs to be combined to give a complete picture. For example:

- an automobile firm can have measures of defects, ability to perform to specifications, durability and ability to repair
- a bank might be concerned with waiting time, accuracy of transactions, and making the customer experience friendly and positive
- a computer manufacturer can examine relative performance specifications, and product reliability as reflected by repair data.

### **Brand awareness and company profile**

Developing and maintaining a brand and/or a company profile can be expensive. However, it can also enhance performance. The value of a brand/company profile is based on the extent to which it has:

- high loyalty
- name awareness
- perceived quality
- other attributes such as patents or trademarks.

NFPs may focus on areas such as customer awareness and consumer opinions.

#### **6.1.11 Difficulties in using and interpreting qualitative information**

Particularly at higher levels of management, non-financial information is often not in numerical terms, but qualitative, or soft, rather than quantitative. Qualitative information often represents opinions of individuals and user groups. However there are issues related to its use.

- Decisions often appear to have been made on the basis of quantitative information; however qualitative considerations often influence the final choice, even if this is not explicit.
- Conventional information systems are usually designed to carry quantitative information and are sometimes less able to convey qualitative issues. However the impact of a decreased output requirement on staff morale is something that may be critical but it is not something that an information system would automatically report.
- In both decision making and control, managers should be aware that an information system may provide a limited or distorted picture of what is actually happening. In many situations, sensitivity has to be used in interpreting the output of an information system.
- Information in the form of opinions is difficult to measure and interpret. It also requires more analysis.
- Qualitative information may be incomplete.
- Qualitative aspects are often interdependent and it can be difficult to separate the impact of different factors.
- Evaluating qualitative information is subjective, as it is not in terms of numbers - there are no objective formulae as there are with financial measures.
- The cost of collecting and improving qualitative information may be very high.
- Difficulties in measurement and interpretation mean that qualitative factors are often ignored.

#### **6.1.12 Models for evaluating financial and non-financial performance**

As discussed, it is important that a business appraises both financial and non-financial performance. There are four key tools available:

- Kaplan and Norton's balanced scorecard
  - The performance pyramid
  - Fitzgerald and Moon's building block model
  - The performance prism
- (a) **Balance Scorecard is discussed later in this Study Note.**
- (b) **Performance Pyramid**

- The performance pyramid, developed by Lynch and Cross, includes a hierarchy of financial and non-financial performance measures.
- The diagram below shows actions to assist in the achievement of corporate vision may be cascaded down through a number of levels, i.e. it shows the link between strategy and day to day operations.

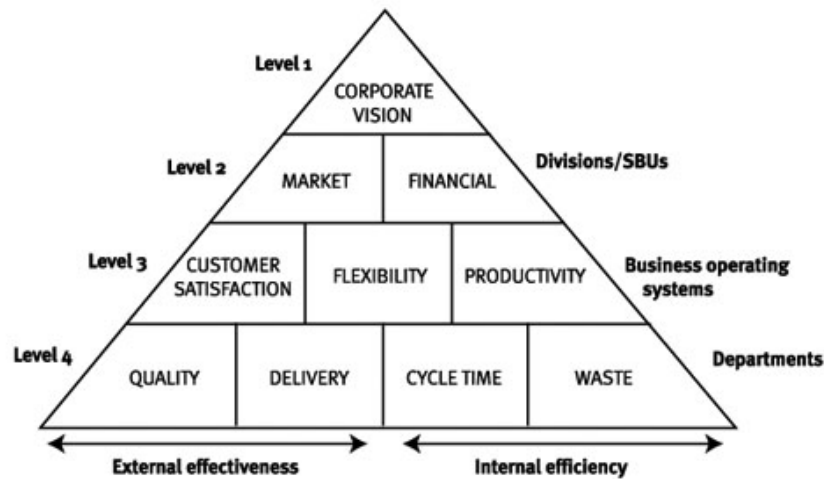

**Fig: Performance Pyramid**

**Level 1:** At the top of the organisation is the corporate vision or mission through which the organisation describes how it will achieve long-term success and competitive advantage.

**Level 2:** This focuses on the achievement of an organisation's Critical Success Factors (CSFs) in terms of market-related measures and financial measures. The marketing and financial success of a proposal is the initial focus for the achievement of corporate vision.

**Level 3:** The marketing and financial strategies set at level 2 must be linked to the achievement of customer satisfaction, increased flexibility and high productivity at the next level. These are the guiding forces that drive the strategic objectives of the organisation.

**Level 4:** The status of the level 3 driving forces can be monitored using the lower level departmental indicators of quality, delivery, cycle time and waste.

The left hand side of the pyramid contains measures which have an external focus and which are predominantly non-financial. Those on the right are focused on the internal efficiency of the organisation and are predominantly financial.

The one **drawback** of the performance pyramid is that it does tend to concentrate on two groups of stakeholders, i.e. shareholders and customers. It is necessary to ensure that measures are included which relate to other stakeholders as well.

(c) **Building Block Model**

- Fitzgerald and Moon have developed an approach to performance measurement in business services that is based on the three building blocks of dimensions, standards and rewards.

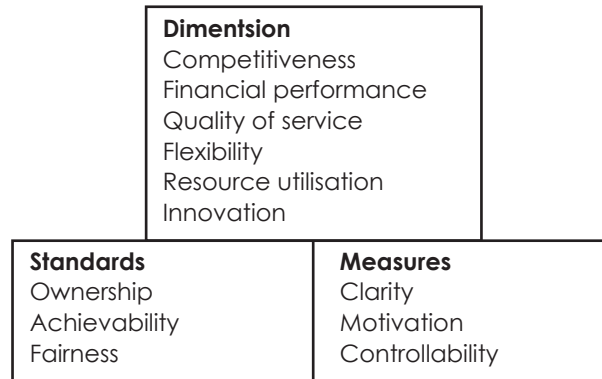

**Fig: Building Block Model**

**Dimensions**

The dimensions are the goals, i.e. the CSFs for the business and suitable measures must be developed to measure each performance dimension.

**Example:**

Dimensions	Type of measure
Competitiveness	Relative market share
Financial performance	Turnover growth
Quality of service	Product reliability
Flexibility	Delivery time
Resource utilisation	Productivity
Innovation	New product numbers

The table above identifies the dimensions of performance. The first two of these relate to downstream results, the other four to upstream determinants. For example, a new product innovation will not impact on profit, cash flow and market share achieved in the past - but a high level of innovation provides an indicator of how profit, cash flow and market share will move in the future. If innovation is the driver or determinant of future performance, it is a key success factor.

**Standards**

The standards set, i.e. the KPIs, should have the following characteristics:

**Ownership:** Managers who participate in the setting of standards are more likely to accept and be motivated by the standards than managers on whom standards are imposed.

**Achievability:** An achievable, but challenging, standard is a better motivator than an unachievable one.

**Fairness:** When setting standards across an organisation, care should be undertaken to ensure that all managers have equally challenging standards.

**Rewards:**

To ensure that employees are **motivated** to meet standards, the standards need to be **clear** and linked to **controllable** factors. The actual means of motivation may involve performance related pay, a bonus or a promotion.

**Fitzgerald and Moon applied to a Washing Machine Manufacturer:**



<b>Dimension = CSF</b>	Flexibility – On time delivery	Quality of service	Financial performance
<b>Standard = KPI</b>	Delivery speed	Reliability	Profitability
<b>Reward</b>	Points for each on time delivery – leading to a bonus	% commission for repair engineers from fee or warranty paid	Management profit related bonuses

(d) **Performance Prism**

Performance Prism creators Andy Neely and Chris Adams maintain that the better-known Balanced Scorecard framework only focuses on two sets of stakeholders: shareholders and customers. It thinks about all of their stakeholders and how organizations can deliver value to them. In the Performance Prism framework, stakeholders include: activists, communities, consumers, employees, legislators, regulators, and suppliers.

Within this methodology, practitioners focus on five major areas:

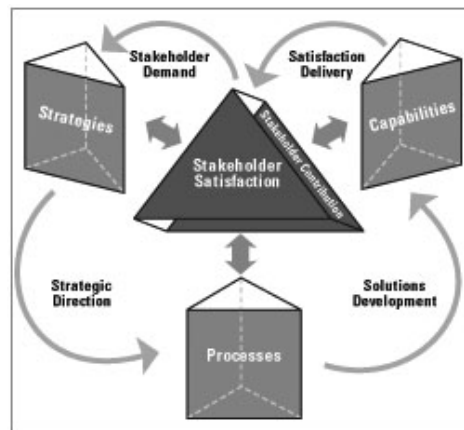
- **Stakeholder Satisfaction:** Who are the key stakeholders? What do they want and need?
- **Strategies:** What strategies does the organization need to put in place to satisfy the wants and needs of these stakeholders?
- **Processes:** What critical processes does the organization need to put in place to satisfy these strategies?
- **Capabilities:** What capabilities does an organization need to operate and to enhance these processes?
- **Stakeholder Contribution:** What contributions does the organization need from its stakeholders to maintain and develop these capabilities?



**Fig: Performance Prism methodology**

### **Performance Prism**

The Performance Prism is a second generation performance measurement and management framework that is innovative in its approach. Its advantages over other frameworks are that it addresses all of an organisation's stakeholders - principally investors, customers & intermediaries, employees, suppliers, regulators and communities. It does this in two ways: by considering what the wants and needs of those stakeholders are and, uniquely, what the organisation wants and needs from its stakeholders. In this way, the reciprocal relationship with each stakeholder is examined. The Performance Prism then addresses the strategies, processes and - importantly - the capabilities that are needed in order to satisfy these two critical sets of wants and needs.

#### **The benefits of these models are as follows:**

- financial and non-financial performance measures are included
- they are linked in to corporate strategy
- include external as well as internal measures
- include all important factors regardless of how easy they are to measure
- show clearly the tradeoffs between different dimensions of performance
- show how measures will motivate managers and employees.

#### **6.1.13 Advantages**

Non-financial measures offer four clear advantages over measurement systems based on financial data. First of these is a closer link to long-term organizational strategies. Financial evaluation systems generally focus on annual or short-term performance against accounting yardsticks. They do not deal with progress relative to customer requirements or competitors, nor other non-financial objectives that may be important in achieving profitability, competitive strength and longer-term strategic goals. For example, new product development or expanding organizational capabilities may be important strategic goals, but may hinder short-term accounting performance.

By supplementing accounting measures with non-financial data about strategic performance and implementation of strategic plans, companies can communicate objectives and provide incentives for managers to address long-term strategy.

Second, critics of traditional measures argue that drivers of success in many industries are "intangible assets" such as intellectual capital and customer loyalty, rather than the "hard assets" allowed on to balance sheets. Although it is difficult to quantify intangible assets in financial terms, non-financial data can provide indirect, quantitative indicators of a firm's intangible assets.

One study examined the ability of non-financial indicators of “intangible assets” to explain differences in US companies’ stock market values. It found that measures related to innovation, management capability, employee relations, quality and brand value explained a significant proportion of a company’s value, even allowing for accounting assets and liabilities. By excluding these intangible assets, financially oriented measurement can encourage managers to make poor, even harmful, decisions.

Third, non-financial measures can be better indicators of future financial performance. Even when the ultimate goal is maximizing financial performance, current financial measures may not capture long-term benefits from decisions made now. Consider, for example, investments in research and development or customer satisfaction programs. Under U.S. accounting rules, research and development expenditures and marketing costs must be charged for in the period they are incurred, so reducing profits. But successful research improves future profits if it can be brought to market.

Similarly, investments in customer satisfaction can improve subsequent economic performance by increasing revenues and loyalty of existing customers, attracting new customers and reducing transaction costs. Non-financial data can provide the missing link between these beneficial activities and financial results by providing forward-looking information on accounting or stock performance. For example, interim research results or customer indices may offer an indication of future cash flows that would not be captured otherwise.

Finally, the choice of measures should be based on providing information about managerial actions and the level of “noise” in the measures. Noise refers to changes in the performance measure that are beyond the control of the manager or organization, ranging from changes in the economy to luck (good or bad). Managers must be aware of how much success is due to their actions or they will not have the signals they need to maximize their effect on performance. Because many non-financial measures are less susceptible to external noise than accounting measures, their use may improve managers’ performance by providing more precise evaluation of their actions. This also lowers the risk imposed on managers when determining pay.

### **6.1.14 Disadvantages**

Although there are many advantages to non-financial performance measures, they are not without drawbacks. Research has identified five primary limitations. Time and cost has been a problem for some companies. They have found that costs of a system that tracks a large number of financial and non-financial measures can be greater than its benefits. Development can consume considerable time and expense, not least of which is selling the system to skeptical employees who have learned to operate under existing rules. A greater number of diverse performance measures frequently requires significant investment in information systems to draw information from multiple (and often incompatible) databases.

Evaluating performance using multiple measures that can conflict in the short term can also be time-consuming. One bank that adopted a performance evaluation system using multiple accounting and non-financial measures saw the time required for Area Directors to evaluate Branch Managers increase from less than one day per quarter to six days.

Bureaucracies can cause the measurement process to degenerate into mechanistic exercises that add little to reaching strategic goals. For example, shortly after becoming the first US company to win Japan’s prestigious Deming Prize for quality improvement, Florida Power and Light found that employees believed the company’s quality improvement process placed too much emphasis on reporting, presenting and discussing a myriad of quality indicators. They felt this deprived them of time that could be better spent serving customers. The company responded by eliminating most quality reviews, reducing the number of indicators tracked and minimizing reports and meetings.

The second drawback is that, unlike accounting measures, non-financial data are measured in many ways, there is no common denominator. Evaluating performance or making trade-offs between attributes is difficult when some are denominated in time, some in quantities or percentages and some in arbitrary ways.



Many companies attempt to overcome this by rating each performance measure in terms of its strategic importance (from say not important to extremely important) and then evaluating overall performance based on a weighted average of the measures. Others assign arbitrary weightings to the various goals. One major car manufacturer, for example, structures executive bonuses so: 40% based on warranty repairs per 100 vehicles sold; 20% on customer satisfaction surveys; 20% on market share; and 20% on accounting performance (pre-tax earnings). However, like all subjective assessments, these methods can lead to considerable error.

Lack of causal links is a third issue. Many companies adopt non-financial measures without articulating the relations between the measures or verifying that they have a bearing on accounting and stock price performance. Unknown or unverified causal links create two problems when evaluating performance: incorrect measures focus attention on the wrong objectives and improvements cannot be linked to later outcomes. Xerox, for example, spent millions of dollars on customer surveys, under the assumption that improvements in satisfaction translated into better financial performance. Later analysis found no such association. As a result, Xerox shifted to a customer loyalty measure that was found to be a leading indicator of financial performance.

The lack of an explicit causal model of the relations between measures also contributes to difficulties in evaluating their relative importance. Without knowing the size and timing of associations among measures, companies find it difficult to make decisions or measure success based on them.

Fourth on the list of problems with non-financial measures is lack of statistical reliability - whether a measure actually represents what it purports to represent, rather than random "measurement error". Many non-financial data such as satisfaction measures are based on surveys with few respondents and few questions. These measures generally exhibit poor statistical reliability, reducing their ability to discriminate superior performance or predict future financial results.

Finally, although financial measures are unlikely to capture fully the many dimensions of organizational performance, implementing an evaluation system with too many measures can lead to "measurement disintegration". This occurs when an overabundance of measures dilutes the effect of the measurement process. Managers chase a variety of measures simultaneously, while achieving little gain in the main drivers of success.

Once managers have determined that the expected benefits from non-financial data outweigh the costs, three steps can be used to select and implement appropriate measures.

#### **6.1.15 Understand Value Drivers**

The starting point is understanding a company's value drivers, the factors that create stakeholder value. Once known, these factors determine which measures contribute to long-term success and so how to translate corporate objectives into measures that guide managers' actions.

While this seems intuitive, experience indicates that companies do a poor job determining and articulating these drivers. Managers tend to use one of three methods to identify value drivers, the most common being intuition. However, executives' rankings of value drivers may not reflect their true importance. For example, many executives rate environmental performance and quality as relatively unimportant drivers of long-term financial performance. In contrast, statistical analyses indicate these dimensions are strongly associated with a company's market value.

A second method is to use standard classifications such as financial, internal business process, customer, learning and growth categories. While these may be appropriate, other non-financial dimensions may be more important, depending on the organization's strategy, competitive environment and objectives. Moreover, these categories do little to help determine weightings for each dimension.

Perhaps the most sophisticated method of determining value drivers is statistical analysis of the leading and lagging indicators of financial performance. The resulting "causal business model" can help determine which measures predict future financial performance and can assist in assigning weightings to measures based on the strength of the statistical relation. Unfortunately, relatively few companies develop such causal business models when selecting their performance measures.



## Review Consistencies

Most companies track hundreds, if not thousands, of non-financial measures in their day-to-day operations. To avoid “reinventing the wheel”, an inventory of current measures should be made. Once measures have been documented, their value for performance measurement can be assessed. The issue at this stage is the extent to which current measures are aligned with the company’s strategies and value drivers. One method for assessing this alignment is “gap analysis”. Gap analysis requires managers to rank performance measures on at least two dimensions: their importance to strategic objectives and the importance currently placed on them.

## Integrate Measures

Finally, after measures are chosen, they must become an integral part of reporting and performance evaluation if they are to affect employee behavior and organizational performance. This is not easy. Since the choice of performance measures has a substantial impact on employees’ careers and pay, controversy is bound to emerge no matter how appropriate the measures. Many companies have failed to benefit from non-financial performance measures through being reluctant to take this step.

## Conclusion

Although non-financial measures are increasingly important in decision-making and performance evaluation, companies should not simply copy measures used by others. The choice of measures must be linked to factors such as corporate strategy, value drivers, organizational objectives and the competitive environment. In addition, companies should remember that performance measurement choice is a dynamic process - measures may be appropriate today, but the system needs to be continually reassessed as strategies and competitive environments evolve.

### 6.1.16 Key Performance Indicators (KPIs)

Key Performance Indicators, also known as KPI or Key Success Indicators (KSI), help an organization define and measure progress toward organizational goals.

Once an organization has analyzed its mission, identified all its stakeholders, and defined its goals, it needs a way to measure progress toward those goals. Key Performance Indicators are those measurements.

Key Performance Indicators are quantifiable measurements, agreed to beforehand, that reflect the critical success factors of an organization. They will differ depending on the organization.

- A business may have as one of its Key Performance Indicators the percentage of its income that comes from repeat customers.
- A school may focus its Key Performance Indicators on graduation rates of its students.
- A Customer Service Department may have as one of its Key Performance Indicators, in line with overall company KPIs, percentage of customer calls answered in the first minute.
- A Key Performance Indicator for a social service organization might be number of clients assisted during the year.

Whatever Key Performance Indicators are selected, they must reflect the organization’s goals, they must be key to its success, and they must be quantifiable (measurable). Key Performance Indicators usually are long-term considerations. The definition of what they are and how they are measured do not change often. The goals for a particular Key Performance Indicator may change as the organization’s goals change, or as it gets closer to achieving a goal.

### Key Performance Indicators Reflect The Organizational Goals

An organization that has as one of its goals “to be the most profitable company in our industry” will have Key Performance Indicators that measure profit and related fiscal measures. “Pre-tax Profit” and “Shareholder Equity” will be among them. However, “Percent of Profit Contributed to Community



Causes" probably will not be one of its Key Performance Indicators. On the other hand, a school is not concerned with making a profit, so its Key Performance Indicators will be different. KPIs like "Graduation Rate" and "Success In Finding Employment After Graduation", though different, accurately reflect the schools mission and goals.

### **Key Performance Indicators Must Be Quantifiable**

If a Key Performance Indicator is going to be of any value, there must be a way to accurately define and measure it. "Generate More Repeat Customers" is useless as a KPI without some way to distinguish between new and repeat customers. "Be The Most Popular Company" won't work as a KPI because there is no way to measure the company's popularity or compare it to others.

It is also important to define the Key Performance Indicators and stay with the same definition from year to year. For a KPI of "Increase Sales", you need to address considerations like whether to measure by units sold or by rupee value of sales. Will returns be deducted from sales in the month of the sale or the month of the return? Will sales be recorded for the KPI at list price or at the actual sales price?

You also need to set targets for each Key Performance Indicator. A company goal to be the employer of choice might include a KPI of "Turnover Rate". After the Key Performance Indicator has been defined as "the number of voluntary resignations and terminations for performance, divided by the total number of employees at the beginning of the period" and a way to measure it has been set up by collecting the information in an HRIS, the target has to be established. "Reduce turnover by five percent per year" is a clear target that everyone will understand and be able to take specific action to accomplish.

### **Key Performance Indicators Must be Key to Organizational Success**

Many things are measurable. That does not make them key to the organization's success. In selecting Key Performance Indicators, it is critical to limit them to those factors that are essential to the organization reaching its goals. It is also important to keep the number of Key Performance Indicators small just to keep everyone's attention focused on achieving the same KPIs.

That is not to say, for instance, that a company will have only three or four total KPIs in total. Rather there will be three or four Key Performance Indicators for the company and all the units within it will have three, four, or five KPIs that support the overall company goals and can be "rolled up" into them.

If a company Key Performance Indicator is "Increased Customer Satisfaction", that KPI will be focused differently in different departments. The Manufacturing Department may have a KPI of "Number of Units Rejected by Quality Inspection", while the Sales Department has a KPI of "Minutes A Customer Is On Hold Before A Sales Rep Answers". Success by the Sales and Manufacturing Departments in meeting their respective departmental Key Performance Indicators will help the company meet its overall KPI.

#### **6.1.17 Measure Business Performance Using Financial Key Performance Indicators**

The key performance indicators are used by a business organization to measure its success. Analysis of these indicators helps the organization measure its success so far and make important decisions for the future.

There are many categories of key performance indicators such as quantitative indicators, directional indicators, financial indicators, and so on. Among others, the financial indicators are very important and must be monitored and measured to learn about overall businesses performance.

In order to measure financial key performance indicators, a business owner needs assistance from accounting professionals. A CPA, for example, can help in measuring financial indicators to estimate how well the company has performed in the past few months or year.

Here are some of the ways in which financial key performance indicators can be measured:

### **Revenue of the Company**

An important financial performance indicator of a company is the revenue generated by it over a specified period. In general, the revenue generated over a year is measured by the accountant hired by the company.

At the beginning of every fiscal year, the company targets specific revenue that it must attain at the end of the year. The role of the accountant is to maintain regular bookkeeping and analyze the financial records at the end of the year.

The profit and loss statements are of great help to a CPA to measure the revenue of the company. So, one can refer to them as the tools that aid performance measurement. A bookkeeper or an accountant has the duty to maintain these records accurately.

### **Defining Budget**

A business budget is another important financial key performance indicator. It is the responsibility of an accountant to plan the budget for a business house and analyze it monthly, quarterly, as well as yearly. The analysis of a budget as a key performance indicator helps a business owner to gauge whether the company has been spending within the budget limits or not. During a specific period, the company may have overspent. The reasons for overspending must be known to the top-level management.

For example, if your company has exceeded budget limitations to replace an old machine, it should be treated as a business investment. However, if the business funds have been misused, it must be brought to the notice of the top management, and measures should be employed to ensure that the same doesn't happen in the future. Thus, it becomes possible for a business to measure its performance based on various expenses over a specified period.

### **Identifying Areas of Improvement**

An important part of measuring business performance based on the key performance indicators is to identify the areas of improvement. By learning about these areas of improvement, a business owner can take necessary steps to improve the overall performance of the company.

Again, a business accountant can assist the top-level managers to learn about the areas of improvement in the financial department. For example, an accountant may find the rate of interest for an existing business loan to be higher than the current interest rates existing in the market.

He can communicate this matter to the manager so that negotiations with lenders can be undertaken to reduce the repayments. In the same way, an accountant can identify the scope of improvement in areas like business credit lending. All these things ultimately assist in measuring the performance of the company and how well it is moving toward its goals.

### **Idle Cash Utilization**

Another important financial key performance indicator is the utilization of cash, which is lying idle with the company. An accountant can calculate how much idle cash is available with the company and can also guide the management on how to utilize it in the beginning of the fiscal year.

For example, there are numerous investment plans that can be used to generate income by investing the unused cash of the business. An accountant can guide the management in choosing the best of these plans.

At the end of the year, the accountant measures the income and profits that the business has made out of these investments over the year. This again helps the company to measure the performance of its funds.

A business must have an efficient tracking system to measure the growth or decline of the financial key performance indicators. This involves the use of accounting and bookkeeping software, accounting metrics, and a variety of other tools. However, the most important requirement is to hire the best professionals for the purpose of business accounting.



### 6.1.18 Non-Financial Key Performance Indicators (KPIs)

A company's financial performance is typically measured by established financial indicators. But how can organizations obtain a holistic assessment of their performance, which includes **corporate responsibility**? Non-financial key performance indicators, or KPIs, enable companies to measure the results of their **corporate responsibility and sustainability** initiatives. By incorporating the appropriate KPIs into their process, companies can gain a more comprehensive understanding of how well they are meeting their corporate responsibility objectives.

As organizations embark on environmental, social and governance initiatives, they are discovering that financial measures alone do not provide an accurate assessment of their corporate responsibility progress. For example, traditional financial indicators do not fully capture all aspects of a company's relationships with its customers, employees and suppliers, or represent its efforts with respect to sustainability.

**“Appropriate KPIs can help companies track and document performance and progress, identify and prioritize corporate responsibility opportunities, improve credibility and accountability, and ultimately enhance stakeholder trust.”**

— Valerie Chort

“Financial performance measures alone aren't a complete indicator of a company's health,” explains Valerie Chort, national leader of Deloitte's Corporate Responsibility & Sustainability practice. “External stakeholders look at a range of non-financial performance measures to assess how well a company is meeting its corporate responsibility objectives. These are seen as a proxy for good management. To communicate this information, companies require relevant non-financial key performance indicators, or KPIs.”

#### **KPIs connect corporate responsibility to performance**

Key performance indicators provide businesses with a means of measuring progress toward achieving objectives. They provide quantitative or qualitative forms of feedback that reflect performance in the context of their business strategy. The approach is no different when managing environmental, social and governance issues. Increasingly, previously assumed externalities such as environmental, social and governance matters are affecting business performance. For example:

- Poor stewardship and management of natural resources can increase costs and reduce efficiency, impacting operational performance;
- Neglecting to incorporate socio-environmental considerations into decision-making can curtail business opportunities, and jeopardize a company's licence to operate;
- Failing to plan for a future in which socio-environmental issues are likely to be a significant source of risk may undermine the long-term value of a business, for example, the mitigation and adaptation requirements of climate change.

In order to adequately capture the link between economic performance and progress in implementing corporate responsibility strategies, it is necessary to develop and use the appropriate non-financial KPIs.

The non-financial KPIs that a business develops, manages against and ultimately reports — whether internally or externally — will depend on its strategic corporate priorities, and will reflect the unique nature of the organization. Companies can use KPIs developed by international organizations, peers and leading companies, or they can develop their KPIs in-house. “The key is to remember that what is measured is managed,” says Chort, “and that it's important to measure what will protect and create value for your company and its stakeholders. Unfortunately, the tendency is to manage what is easy to measure.”

### **A comprehensive view of corporate responsibility performance**

KPIs can help companies plan and manage their environmental, social and governance priorities — particularly when KPIs are linked to core business strategies through action plans that include performance targets. Moreover, the actual process of defining, selecting and measuring non-financial KPIs adds value by providing a more informed view of the company's economic performance.

When communicated externally, these KPIs form a critical foundation of a company's **corporate responsibility reporting**. As leading indicators of business performance, non-financial KPIs can provide deep insight into a company's corporate responsibility performance, while also reflecting effective governance and corporate risk management. As Chort notes, "Appropriate KPIs can help companies track and document performance and progress, identify and prioritize corporate responsibility opportunities, improve credibility and accountability, and ultimately enhance stakeholder trust.

#### **6.1.19 Using Key Performance Indicators to Increase Productivity and Profitability**

In most businesses, the employees represent both an organization's biggest expense, and its most valuable asset. This means the company's productivity, and ultimately, its profitability depend on making sure all of its workers perform up to, if not exceed their full potential.

To survive and prosper in today's economic times, companies can no longer manage using financial measures alone. Businesses have to track non-financial measures such as speed of response and product quality; externally focused measures, such as customer satisfaction and brand preference; and forward looking measures, such as employee satisfaction, retention and succession planning.

Key Performance Indicators (KPIs) are a company's measurable goals, typically tied to an organization's strategy, as revealed through performance management tools such as the Balanced Scorecard.

Most goals are achieved not through the efforts of a single person, but by multiple people in a variety of departments across an organization. Performance management experts agree that cascading and aligning goals across multiple owners creates a "shared accountability" that is vital to a company's success. The company then uses its Key Performance Indicators as the foundation to analyze and track performance and base key strategic decisions regarding staffing and resources.

Implementing the key performance indicators of a balanced scorecard typically includes four processes:

- The company translates its corporate vision into measurable operational goals that are communicated to employees.
- These goals are linked to individual performance goals which are assessed on an established periodic basis.
- Internal processes are established to meet and / or exceed the strategic goals and customer expectations.
- Finally, Key Performance Indicators are analyzed to evaluate and make recommendations to improve future company performance.

Here are some of the benefits of using Key Performance Indicators through the Balanced Scorecard methodology as a measurement of a company's success:

- Employees and managers see the overall corporate goal plan—and understand how their individual goals fit into the company's business objectives creating a situation in which employees feel energized and engaged in the success of the company.
- Create shared employee responsibility—by cascading his or her goals with others in the company.
- Managers more easily stay in touch with employees' progress—during every phase of goal completion, and offer immediate reinforcement or coaching to keep performance and deadlines on track.



- Creating an open and communicative environment including quality feedback regarding goals and progress

### **Cascading Your Strategy Throughout Your Company**

Cascading your corporate goals throughout the organization lets you align your entire workforce to the overall strategy. This ensures that everyone is focused on your key business objectives. Translating high-level strategic goals into clear objectives for every business unit and every employee creates a clear line-of-sight - from top down and bottom up—so each individual understands how their day-to-day actions are contributing to overall company success.

This also allows employees to develop goals that link to the organization's objectives, driving understanding of strategy, generating commitment, and instilling personal accountability.

## **6.2 METHODS FOR IMPROVEMENT OF PRODUCTIVITY & PROFITABILITY**

### **6.2.1 Productivity**

Productivity is about the effective and efficient use of all resources. Resources include time, people, knowledge, information, finance, equipment, space, energy, materials.

To manage the resources of a business it is essential that you

- understand exactly what needs to be done to meet customer demand
- establish a plan that clearly identifies the work to be carried out
- define and implement the methodologies that need to be used to complete all activities and tasks efficiently
- establish how long it will actually take to complete each activity and task
- determine what resources you need to meet the plan
- provide the necessary resources and initiate the plan
- constantly monitor what is actually happening against the plan
- identify variances and take the relevant actions to correct them or modify the plan

Productivity is often linked with “time and motion”. The evidence of time and motion studies was used to put pressure on workers to perform faster. Not surprisingly these studies had a bad press as far as workers were concerned. Similarly the image of “time and motion” doesn't sit well with the productivity specialists.

The real responsibility for productivity or performance improvement should be largely in the hands of those organising the work rather than the individual worker.

#### **Productivity = Value / Time**

(productivity equals value divided by time)

By this definition there are two primary ways of increasing productivity:

- 1) Increase the value created
- 2) Decrease the time required to create that value

You can complicate this definition by including other factors like energy and resources, but in most cases factors like energy and resources are reducible to time anyway. Time also makes it very easy to compare different levels of productivity, such as output per hour or per day.

Apparently you can make some significant gains on the time side. There are many personal productivity optimizations which, especially if you introduce them in your youth, will produce a massive net savings

of time over the course of your life. Consider your typing speed, for instance. If you invest the time to get your speed up to 90 words per minute or faster, it will be well worth the initial time investment if you happen to do a lot of typing over your lifetime, compared to allowing your speed to linger at 50 wpm or slower year after year. The extra hours of practice will be nothing compared to the time you save typing emails, letters, or blog entries over the next few decades. Other time-based optimizations include improving your sleeping habits, minimizing commute time, or dropping time-wasting habits like smoking.

The main limit of time-based optimizations is that the optimization process requires an input of time itself. It takes time to save time. So the more time you invest in optimizing time usage, the greater your initial time investment, and the greater your need for a long-term payoff to justify that investment. This limit creates an upper bound for any time-based optimizations you attempt, in accordance with the law of diminishing returns. The more time you invest in any optimization attempt, the lower your net return, all else being equal.

This law of diminishing returns points us back to the value side. While we might be stuck with diminishing returns by trying to optimize the time side alone, we may notice that working to optimize the value side is less limiting and more open-ended.

What is the “value” in our productivity equation?

Value is a quality you must define for yourself. Hence, any definition of productivity is relative to the definition of value. In circles where people can agree on a common definition of value, they can also agree on a common definition of productivity. However, in terms of your own personal productivity, you aren't obligated to define value the same way anyone else would. You are free to adopt your own definition, such that your pursuit of greater productivity becomes a personal quest that produces the value that matters most to you.

Too often we adopt a socially conditioned definition of value, which tends to be very limiting. Perhaps we define value in terms of work output within our career, number of tasks completed, number and quality of important projects finished, etc. You may not be able to verbalize it clearly, but perhaps you have a working definition of value that feels comfortable to you. You can tell when you've had a productive day and when you haven't based on how much value you created, in accordance with your own sense of what value means.

### **Impact**

First, according to your definition of value, to what extent is the value provided? Who receives the value? Yourself, your boss, your coworkers, your friends, your family, your company, your customers, your team, certain investors, your community, your country, the world, your family, God, all conscious beings, etc? What degree of value is ultimately received by each person or group? Are you providing value to one person, 10 people, 100 people, 1000 people, millions of people, the whole planet? How much do you feel the value you provide ripples outward beyond those you provide it to directly? How quickly do those ripples dissipate? What's your sense of the basic level of impact of your value? Is it limited or expansive?

For example, if you're the CEO of a Fortune 500 corporation or the leader of a country, you'll have a far greater ability to provide value to large numbers of people vs. if you work as a janitor. The more people you can influence, the greater your potential value. Greater leverage means greater potential impact.

### **Endurance**

Secondly, how long does the value you create endure? An hour, a day, a week, a month, a year, a decade, a lifetime, 100 years, 1000 years, 10,000 years, until the end of time? To what extent does your value carry forward in time? Is it quickly consumed and forgotten? Or does it continue to regenerate itself year after year? Does your value create ripples through time?



The Mona Lisa is still providing value hundreds of years after its creation. But other works of art do not provide any enduring value beyond the lifetime of the artist. They are quickly abandoned and eventually replaced.

### **Essence**

Thirdly, what is the essence of the value you produce? Do you help people survive? Entertain them? Enlighten them? How much do others value what you produce? What price would they be willing to pay for it? Do they consider your value essential, optional, or undesirable? How unique is your value? Are you the only one who can provide it, or are there plenty of equivalent choices?

The essence of value provided by a janitor is low because it is easy to find people to do such work for little pay. The essence of value of a physicist is potentially enormous because a new theoretical concept could yield a more accurate understanding of the universe.

### **Volume**

Lastly, what is the volume of value you create? How much of it are you putting out in a given period of time? What is the quantity in which you produce that value?

For example, Picasso was a prolific artist who created hundreds of different works over his lifetime. Other artists had a far lower volume of output.

So now we have this little formula:

$$\text{Value} = \text{Impact} \times \text{Endurance} \times \text{Essence} \times \text{Volume}$$

And therefore:

$$\text{Productivity} = \text{Impact} \times \text{Endurance} \times \text{Essence} \times \text{Volume} / \text{Time}$$

Now what's interesting here is that most of the productivity literature focuses almost exclusively on volume and time. But those are the most limiting parts of this equation. However, they're also the easiest to write about.

The most important long-term factors to consider when optimizing productivity (whether that of an individual, corporation, country, or other entity) are impact, endurance, and essence. And the most important of these three is essence.

For example, let's consider the productivity of a blogger.

The impact of a blogger's value would be related to the blog's traffic levels and overall influence among its readers. How many people are reading the blog, and how much do they value what the blogger writes? To improve impact a blogger could increase traffic to the blog or improve his/her writing skills in order to have a deeper effect on the readers. Impact can also be increased if the readers then go out and tell others about what they've read. Furthermore, the blogger could use the blog as a means for self-exploration, thereby increasing the impact of the blog on the blogger's own life.

The endurance of a blogger's value would be the long-term effect on the blog's readers, if any. Is the blog changing the long-term thinking and behavior patterns of its readers? Do the readers quickly forget what they read on the blog, or does the information stay with them? Are the readers permanently haunted by what they've read?

The essence of a blogger's value depends on the topics the blogger writes about. Is the blogger writing throw-away posts to get a laugh or generate traffic, or is there a serious commitment to providing deep value? What is the nature of the blogger's value delivery? Is it financial advice that could help a person become wealthy? Does it provide solutions to important problems? Or is it mostly fluff?

And of course the volume of a blogger's value would be the quantity of words and posts the blogger delivers.



Now extend this line of thinking to your life as a whole, well beyond the boundaries of your career.

What is the ultimate impact of your life? How many lives are you touching? Are you a person of influence? Or do you exist in relative obscurity?

What will be the endurance of your life's value? Will your lifetime contributions turn out to be largely insignificant? Or will your contributions ripple on for centuries? What of your value will survive your own death? What of your value will you have the potential to retain after you die (assuming there is an afterlife of sorts)?

And finally, what will be the essence of your life's value? What is the heart of your contribution? Are you here to play follow the follower? Are you in pursuit of a worthwhile destiny? When you consciously consider the value you're providing, do you feel empty and fearful or peaceful and fulfilled? What is the meaning behind your deeds? Was that meaning consciously chosen?

You cannot optimize your productivity without consciously and deliberately optimizing these factors. True productivity is far more than volume / time. If you neglect the importance of impact, endurance, and essence, you doom yourself to the pursuit of spinning your wheels faster and faster and missing the whole point of life. And the worst part is that as you live, you will know this to be true. You will sense the hollowness and emptiness in all that you do. When you consider your output in light of the boundlessness of time and space, it becomes nothing.

Essence is the single most important factor. Until you discover the true essence of your life, you can never really be productive. You can take for granted that any task you perform will have a nonzero impact, endurance, and volume. Those factors may be very small if the task is trivial, but they'll be greater than zero. However, if the core essence of any task amounts to zero, then your total productivity is zero. If you miss the point of your life, your ultimate productivity is zero, no matter how hard you work and how well you attempt to optimize all the other factors. If you gain the whole world and lose your soul, your ultimate payoff is zero.

That essence is your purpose.

This is why it's so important to discover your life's purpose. It doesn't matter how long it takes. In fact, the only truly productive task you can perform before you know your purpose is to work to discover what that purpose is. The pursuit of essence is essential if you wish to have a nonzero productivity.

Once you discover your essence, you'll find that all those other factors begin to optimize themselves very easily. Embracing essence creates passion, and passion increases impact, endurance, and volume. Passion also makes time seem to pass more slowly. Passion provides the energy and attracts the resources to manage time more efficiently. Passion allows you to see the present moment as inherently complete and perfect instead of perceiving life as incomplete and imperfect. The discovery of essence automatically optimizes productivity as a whole.

Find a person who knows and embraces their life's purpose, and you'll find a truly productive person. But in the absence of purpose, you'll find busyness, but never productivity — the volume of output created might as well be tossed on the trash heap. It will have no power to endure.

Purpose is rooted in the permanent, the timeless, the unbounded. It is the essence of what is real. Purpose is conscious and alive. Outside of purpose you can work only with the temporary, the timebound, the limited — the ghost projections of reality but not reality itself.

One of the major causes of company's decline is low productivity. Failure to meet targeted productivity can result to high costs per unit, hence higher prices, making your good, services, or commodities not competitive enough on the market.

Many businesses try very hard to remain competitive in the market. Therefore, it is important for businesses to implement strategies to make improvements in productivity levels.

Twelve productivity improvement techniques are explained as follows:

1. **Value Engineering (VE)** : Value Engineering (VE) is the process of improving the value of a product at every stage of the product life cycle. At the development stage, VE improves the value of a product by reducing the cost without reducing quality. At the maturity stage, VE reduces the cost by replacing the costly components (parts) by cheaper components. VE also tries to improve the value and quality of the product. Value is the satisfaction which the consumer gets by using the product. VE tries to give maximum value for a lowest price.
2. **Quality Circles (QC)** : The concept of Quality Circles (QC) was introduced in **1960** in **Japan**. QC is a small group of employees who meet regularly to identify, analyse, and solve problems in their department. The QC members advise the management to implement new methods to solve work-related problems. QC increases the productivity.
3. **Financial and Non-Financial Incentives** : The organisation must motivate the employees by providing financial and non-financial incentives. The financial incentives include better wages and salaries, bonus, etc. The non-financial incentives include better working conditions, welfare facilities, worker's participation in management, etc.
4. **Operations Research (OR)** : Operations Research (OR) uses mathematical and scientific methods to solve management problems, including problems of productivity. QR technique uses a scientific method to study the alternative courses of actions and to select the best alternative. OR uses techniques such as linear programming, game theory, etc., to make the right decision. Thus, QR helps to improve productivity.
5. **Training** : Training is a process of increasing the knowledge and skills of the employees. Training is a must, for new employees and experienced employees. Training increases the efficiency of the employee. Thus, training results in high productivity.
6. **Job Enlargement** : Job Enlargement is a horizontal expansion of a job. It is done to make jobs more interesting and satisfying. It involves increasing the variety of duties. For e.g. a typist may be given the job of accounts writing in addition to the typing work. This technique is used for lower level jobs.
7. **Job Enrichment** : Job Enrichment is a vertical expansion of a job. It makes routine jobs more meaningful and satisfying. It involves providing more challenging tasks, and responsibilities. For e.g. a manager who prepares performance reports is asked to make plans for his department. Job Enrichment technique is used for higher-level jobs.
8. **Inventory Control** : There must be a proper level of inventory. Overstocking and under stocking of inventories must be avoided. Overstocking of inventories will result in blocking of funds and there are chances of spoilage or misuse of materials. Under stocking of inventories will result in shortages. This will block the smooth flow of production, and so the delivery schedules will be affected.
9. **Materials' management** : Materials' management deals with optimum utilisation of materials in the manufacturing process. It involves scientific purchasing, systematic store keeping, proper inventory control, etc. The main objective of materials' management is to purchase the right quantity and quality materials, at the right prices, at the right time, to maintain favourable relations with suppliers, to reduce the cost of production, etc.
10. **Quality Control** : The main objective of quality control is to produce good quality goods at reasonable prices, to reduce wastages, to locate causes of quality deviation and to correct such deviations, to make the employees quality conscious, etc.
11. **Job Evaluation** : Job Evaluation is a process of fixing the value of each job in the organisation. It is done to fix the wage rate for each job. A proper job evaluation increases the moral of the employees. This increases the productivity.

12. **Human factor engineering** : Human factor engineering refers to the man-machine relationship. It is designed to match the technology to a human requirement. The term **Ergonomics** has originated from the Greek word 'ergos' meaning 'Work' and 'nomikos' meaning 'Law'. So, it means 'Law of Work'. It tells us how to fit a job to a man's psychological and physiological characteristics to increase human efficiency and well-being.

**6.2.2 Profitability**

Profitability is the primary goal of all business ventures. Without profitability the business will not survive in the long run. So measuring current and past profitability and projecting future profitability is very important.

Profitability is measured with income and expenses. Income is money generated from the activities of the business. For example, if crops and livestock are produced and sold, income is generated. However, money coming into the business from activities like borrowing money do not create income. This is simply a cash transaction between the business and the lender to generate cash for operating the business or buying assets.

Expenses are the cost of resources used up or consumed by the activities of the business. For example, seed corn is an expense of a farm business because it is used up in the production process. Resources such as a machine whose useful life is more than one year is used up over a period of years. Repayment of a loan is not an expense, it is merely a cash transfer between the business and the lender.

**Table 1. Income statement.**

<b>Income</b>	
Sale of Crop Products	\$ 50,000
Sale of Livestock Products	\$ 25,000
Government Payments	\$ 10,000
<b>Total Income</b>	<b>\$ 85,000</b>
<b>Expenditure</b>	
Seed	\$ 10,000
Fertilizer	\$ 20,000
Feed	\$ 10,000
Processing	\$ 10,000
Marketing	\$ 5,000
Interest	\$ 5,000
Depreciation	\$ 10,000
<b>Total Expenses</b>	<b>\$ 70,000</b>
<b>Net Income</b>	<b>\$ 15,000</b>

Profitability is measured with an "income statement". This is essentially a listing of income and expenses during a period of time (usually a year) for the entire business. Decision Tool Income Statement - Short Form, is used to do a simple income statement analysis. An Income Statement is traditionally used to measure profitability of the business for the past accounting period. However, a "pro forma income statement" measures projected profitability of the business for the upcoming accounting period. A budget may be used when you want to project profitability for a particular project or a portion of a business.



## Reasons for Computing Profitability

Whether you are recording profitability for the past period or projecting profitability for the coming period, measuring profitability is the most important measure of the success of the business. A business that is not profitable cannot survive. Conversely, a business that is highly profitable has the ability to reward its owners with a large return on their investment.

Increasing profitability is one of the most important tasks of the business managers. Managers constantly look for ways to change the business to improve profitability. These potential changes can be analyzed with a pro forma income statement or a Partial Budget. Partial budgeting allows you to assess the impact on profitability of a small or incremental change in the business before it is implemented.

A variety of Profitability Ratios (Decision Tool) can be used to assess the financial health of a business. These ratios, created from the income statement, can be compared with industry benchmarks. Also, Income Statement Trends (Decision Tool) can be tracked over a period of years to identify emerging problems.

## Accounting Methods

### Cash Method of Accounting

An accounting system that doesn't record accruals but instead recognizes income (or revenue) only when payment is received and expenses only when payment is made. There's no match of revenue against expenses in a fixed accounting period, so comparisons of previous periods aren't possible.

The cash method is simple in that the business's books are kept based on the actual flow of cash in and out of the business. Income is recorded when it's received, and expenses are reported when they're actually paid. The cash method is used by many sole proprietors and businesses with no inventory. From a tax standpoint, it's sometimes advantageous for a new business to use the cash method of accounting. That way, recording income can be put off until the next tax year, while expenses are counted right away.

The cash method may also continue to be appropriate for a small, cash-based business or a small service company.

Cash basis accounting does not conform with the provisions of GAAP and is not considered a good management tool because it leaves a time gap between recording the cause of an action (sale or purchase) and its result (payment or receipt of money). It is, however, simpler than the accrual basis accounting and quite suitable for small organizations that transact business mainly in cash.

### Accrual Method of Accounting

The accounting method under which revenues are recognized on the income statement when they are earned (rather than when the cash is received). The balance sheet is also affected at the time of the revenues by either an increase in Cash (if the service or sale was for cash), an increase in Accounts Receivable (if the service was performed on credit), or a decrease in Unearned Revenues (if the service was performed after the customer had paid in advance for the service).

Under the accrual basis of accounting, expenses are matched with revenues on the income statement when the expenses expire or title has transferred to the buyer, rather than at the time when expenses are paid. The balance sheet is also affected at the time of the expense by a decrease in Cash (if the expense was paid at the time the expense was incurred), an increase in Accounts Payable (if the expense will be paid in the future), or a decrease in Prepaid Expenses (if the expense was paid in advance)

## Defining Profitability

Profitability can be defined as either accounting profits or economic profits.

### **Accounting Profits (Net Income)**

Accounting profit is the profit of a business that includes all revenue and expense items mandated under an accounting framework, such as Generally Accepted Accounting Principles (GAAP) or International Financial Reporting Standards (IFRS). Thus, if total recorded revenues exceed total recorded expenses, the remainder is an accounting profit. Conversely, if total recorded revenues are less than total recorded expenses, the remainder is an accounting loss.

The accounting profit equation is:

Revenue per GAAP or IFRS - Expenses per GAAP or IFRS) = Accounting profit/loss.

### **Economic Profit**

Economic profit is a measure of cost beyond accounting profit. Accounting profit is the money made after all expenses have been paid. It accounts only for actual money earned and spent. Economic profit, by contrast, adds to the equation the cost of options not taken. These options are known as opportunity cost. They include, for example, foregone salary from a job not taken, foregone interest from an investment not made and foregone returns from ventures passed over. Subtracting opportunity cost from an accounting profit can result in an economic loss. This loss, however, does not diminish the money the firm has made.

### **Profitability is not Cash Flow**

People often mistakenly believe that a profitable business will not encounter cash flow problems. Although closely related, profitability and cash flow are different. An income statement lists income and expenses while the cash flow statement lists cash inflows and cash outflows. An income statement shows profitability while a cash flow statement shows liquidity.

Many income items are also cash inflows. The sale of crops and livestock are usually both income and cash inflows. The timing is also usually the same (cash method of accounting) as long as a check is received and deposited in your account at the time of the sale. Many expense items are also cash outflow items. The purchase of livestock feed is both an expense and a cash outflow item. The timing is also the same (cash method of accounting) if a check is written at the time of purchase.

However, there are many cash items that are not income and expense items, and vice versa. For example, the purchase of a tractor is a cash outflow if you pay cash at the time of purchase as shown in the example in Table 2. If money is borrowed for the purchase using a term loan, the down payment is a cash outflow at the time of purchase and the annual principal and interest payments are cash outflows each year as shown in Table 3.

The tractor is a capital asset and has a life of more than one year. It is included as an expense item in an income statement by the amount it declines in value due to wear and obsolescence. This is called "depreciation". The depreciation expense is listed every year. In the tables below a ₹70,000 tractor is depreciated over seven years at the rate of ₹10,000 per year.

Depreciation calculated for income tax purposes can be used. However, to accurately calculate net income, a more realistic depreciation amount should be used to approximate the actual decline in the value of the machine during the year.

In Table 3, where the purchase is financed, the amount of interest paid on the loan is included as an expense, along with depreciation, because interest is the cost of borrowing money. However, the principal payments are not an expense but merely a cash transfer between you and your lender.



**Table 2. Tractor purchase - no borrowing.**

Purchase of a ₹70,000 tractor, no money borrowed, depreciated over seven years.

	<u>Cash Outflow</u>	<u>Expenses</u>
Current Period	₹70,000	
Year 1		₹10,000
Year 2		₹10,000
Year 3		₹10,000
Year 4		₹10,000
Year 5		₹10,000
Year 6		₹10,000
Year 7		₹10,000
Total	₹70,000	₹70,000

**Table 3. Tractor purchase - no borrowing.**

Purchase of a ₹70,000 tractor, ₹45,000 down payment, ₹25,000 paid over five year, seven percent interest, depreciated over seven years.

	<u>Cash Outflow</u>	<u>Expenses</u>
Current Period	₹45,000	₹0
Year 1	₹5,000 principal ₹1,750 interest	₹10,000 depreciation ₹1,750 interest
Year 2	₹5,000 principal ₹1,400 interest	₹10,000 depreciation ₹1,400 interest
Year 3	₹5,000 principal ₹1,050 interest	₹10,000 depreciation ₹1,050 interest
Year 4	₹5,000 principal ₹700 interest	₹10,000 depreciation ₹700 interest
Year 5	₹5,000 principal ₹350 interest	₹10,000 depreciation ₹350 interest
Year 6	₹0	₹10,000 depreciation
Year 7	₹0	₹10,000 depreciation
Total	₹75,250	₹75,250

### Other Financial Statements

An income statement is only one of several financial statements that can be used to measure the financial strength of a business. Other common statements include the balance sheet or net worth statement and the cash flow statement, although there are several other statements that may be included.

These statements fit together to form a comprehensive financial picture of the business. The balance sheet or Net Worth Statement shows the solvency of the business at a specific point in time. Statements are often prepared at the beginning and ending of the accounting period (i.e. January 1). The statement records the assets of the business and their value and the liabilities or financial claims against the business (i.e. debts). The amount by which assets exceed liabilities is the net worth of the business. The net worth reflects the amount of ownership of the business by the owners.

The Cash Flow Statement is a dynamic statement that records the flow of cash into and out of the business during the accounting period. A positive (negative) cash flow will increase (decrease) the working capital of the business. Working capital is defined as the amount of money used to facilitate business operations. It is calculated as current assets (cash or near cash assets) less current liabilities (liabilities due during the upcoming accounting period).

**Figure 1. Integrated financial statements.**

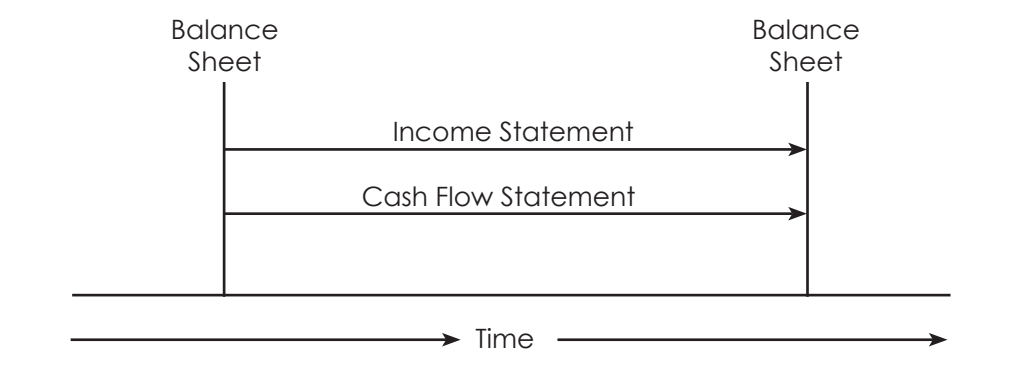

A Complete set of Financial Statements (Decision Tool), including the beginning and ending net worth statements, the income statement, the cash flow statement, the statement of owner equity and the financial performance measures is available to do a comprehensive financial analysis of your business.

To help you assess the financial health of your business, Financial Performance Measures allows you to give your business a check-up. Interpreting Financial Performance Measures helps you to understand what these performance measures mean for your business.

**Methods to improve profitability**

Companies facing the poor economy and a tough profit situation may react with hasty decisions that can create unexpected problems down the road. Many organizations have been looking for ways to cut costs, become more efficient, and exit unprofitable services or products

–but depending on the approach these actions sacrifice long-term goals and potential rewards.

Ad hoc cost-cutting often erodes morale, damages a company's reputation, and degrades infrastructure. By contrast, a disciplined, enterprise-wide profit improvement initiative is a practical way to improve financial results and build a sustainable culture of cost consciousness.

A successful Profit Improvement Program begins at the top. Your executive team must be focused on the bottom line and ready for change. But, before you get your best and brightest in the war room and start reevaluating your current projects, head count, operating model, and balancing the risk/reward of providing such perks as company-paid parking, you must truly understand the strategic direction of the company and the respective drivers of costs within the organization.

If you have not revisited your strategic plan recently, you should. The macro economy has changed course and is certain to have had an effect on some of the goals and plans that your company established the last time strategic planning was performed. A thoughtful approach in developing your strategy will allow you to align your resources to create the most impact for your company.



### **Situational analysis: Establish a baseline**

Strategic planning begins with an up-front situational analysis. It is imperative for the executive team to have a heavy dose of appropriate data in order to make informed decisions. If your organization has not performed a self assessment or a customer assessment recently, now is the time. In the current economy we have found that customers' value statements have changed. Any assessment should minimally include:

- A financial assessment–Benchmark key industry and related financial performance indicators; trend your revenue streams and expense streams over time; identify productivity ratios such as hours worked per unit produced or collected service hours provided. Determine growing products/markets, customer-specific costs, and anomalies, as well as industry and company-specific trends.
- A self assessment–Each member of the management team should assess what has gone well and what has not over the last 12 months.
- A customer assessment –Ideally, this would be a questionnaire or set of interviews with customers across your segments targeting feedback that will allow you to understand the critical value drivers your company provides over your competitors (the reason customers buy from you). We have found that customers are putting more emphasis on cost and less on such things as service than they have in the past.
- A critical issues, constraints and dependencies list–Each member of the team should identify perceived issues, constraints and dependencies within their function and also within the company. Having this information handy will allow the team to further understand the dynamics of potentially implementing a new strategy and where operations can be improved. Often times, departments and business units compete for shared resources such as Information Technology, identifying these interdependencies up front will allow you to be more practical with decision making.
- A SWOT (Strengths, Weakness, Opportunities and Threats) analysis–Identify external and internal factors affecting your organization and how you stack up against them. Analyze your products and services against organizations with which you compete for business (competitive analysis). Identify methods to build on your strengths and address areas for improvement.
- A current list of initiatives–Understanding the organizations current portfolio of projects and strategic objectives will provide the group a realization of where resources are currently focused and reaffirm the current direction of the company. The assessment of the initiatives should include an examination of the initial desired benefit, the results, return on investment and overall business case.

Coming out of the strategic planning meeting, you should have a clear understanding of how to align tangible and intangible resources to drive customer value and positively affect the bottom line. The planning session will identify the cause-and-effect relationships throughout the organization of any one specific strategy.

Ultimately, the organizational goals will be to either increase productivity or efficiency across market segments or, alternatively, to focus on growing certain products/services. Intuitively, the exercise will identify the “sacred cows” of the business –the critical and core processes, people and systems required to maintain a competitive advantage.

The management team also should identify potential enterprise-wide costs, functional-specific costs and direct product or service operating expenses to target for productivity or efficiency improvements. Non-core elements of the business should be reassessed. Seek to understand the drivers of operating activity. Obviously, capturing the thoughts in a compelling manner and rolling them down into an appropriate management structure is absolutely crucial to meeting your identified organizational goals.



### Creating a cost-conscious culture

A Profit Improvement Program is a holistic and programmatic way of developing a cross-functional team to “own” a number of initiatives targeted at improving profit and cash flow within your company. The team should be charged with understanding the strategic direction of the organization (in order to prevent changes that could have catastrophic impacts to the long-term goals of the company) and also with identifying opportunities for cost savings or margin improvement. They should be held accountable for improved financial results and be incentivized to identify and implement successful margin-improving tactics.

A critical first step is to gain organization-wide support for the cost-cutting initiatives and create a culture of cost consciousness. Communicate effectively and often to the employees that many changes are coming as a result of the current financial situation and that teamwork and collaboration are required to improve operating margins. Create a reward system for employees to stimulate ideas for improving productivity and decreasing costs, or for innovative ideas that could create an improved product or new growth market. A bottom-up reward system is a terrific way to get buy-in within the organization.

After establishing and communicating the Profit Improvement initiative and its objectives throughout the organization, it is time to identify specific initiatives to pursue. Initiatives should be analyzed for bottom-line impact, implementation effort required and effects on other areas of the business.

Going through this effort allows the Profit Improvement team to prioritize and manage its efforts to achieve targeted operational and financial goals. Getting tactical: Profit Improvement teams

Establishing a programmatic and team-based approach to focus on key cost and revenue drivers in the business is the true value of the Profit Improvement Program. Each team should work with the finance department to identify the respective costs and revenue components within their area. For effective implementation, accountability for achieving established financial targets must be in place, and the proper identification and reporting of key measurements must be made available to the executive team to ensure that the program(s) are proceeding as planned.

A typical structure that we often use when working with our clients is to organize our teams in the following method:

- **Cash flow:** A focus on improving the cash conversion cycle to provide increased cash flow for operations and strategic capital investment.
- **Revenue and margin management:** A focus on improving revenue and margin at a customer, product or service line level.
- **Spend management:** A focus on lowering enterprise third party or supplier spend by performing a robust review –often saving 5 to 20 percent of all spend. The Spend Management team will perform category-level analytics, identify potential spend opportunities (sourceable spend) and then develop strategies around the opportunities to drive down costs.
- **Operations:** A focus on increasing throughput in processes, sizing processes appropriately for demand, eliminating waste and transforming operations into a performance-based organization. Doing so will increase efficiency and reduce costs yielding a high ROI.
- **Infrastructure:** Focuses on enterprise-wide policies and procedures; indirect and often shared functions, such as training, marketing, human resources and information technology; and the general operating model of the company. The break-out of the teams in this manner allows for focused effort on areas within businesses that generally can be affected to yield impactful bottom-line change.

In difficult economic times, many companies are under immense pressure to adapt their operations in order to improve their bottom line. However, companies that make significant decisions without first building the necessary strategic foundation and structured disciplined approach, may do more harm than good.



By carefully evaluating the impactful financial and operational drivers of the company and implementing a programmatic approach to achieving improved financial results, your organization will benefit from a thoughtful and sound Profit Improvement Program that yields a vastly improved bottom line to achieve both near-term and longer-term strategic financial goals.

### **Improving Profitability through People and Organizational Excellence**

**“Productivity is the optimized utilization and management of all available resources, investigation into the best known resources, the generation of new resources, through creative thinking, innovation technology, and research and development. It combines the best use of all areas of knowledge, improvement techniques, methods, and approaches for the production and distribution of quality goods and services at minimum unit cost in an ethical and legal manner with due regard for the total environment.”**

The second definition, contained in the 2007 Malcolm Baldrige National Quality Criteria for Business Excellence, is:

**“The term productivity refers to measures of the efficiency of resource use. Although the term is often applied to single factors such as workforce (labor productivity), machines, materials, energy, and capital, the productivity concept applies as well to the total resources used in producing outputs. The use of an aggregate measure of overall productivity allows a determination of whether the net effect of overall changes in a process—possibly involving resources tradeoffs—is beneficial.”**

It has been said that productivity and quality are opposite sides of the same coin. Management understands the term productivity, but quality is more easily understood by the workforce and customers. It is not possible to achieve one without the other. Most of the business excellence frameworks have their roots in productivity, but the output is quality. Quality needs to be more strictly defined because it can be an emotional word like “love,” “hate,” or “fear.” But we recognize quality when we see it and we recognize poor quality when it is absent. In the customer-driven excellence model, “Performance and quality are judged by an organization’s customers.”

On reviewing the various business excellence frameworks from a people perspective, the drive to achieve profitability cannot have the expected results without the constant engagement of the workforce and stakeholders in the enterprise. The two key drivers in successful organizations, according to the business excellence frameworks and most leading top management educators, are leadership and customer focus. These are the “push” and “pull,” respectively, of productivity. High-performing organizations exhibit certain characteristics, which are all delivered through or by the people in them. Fundamental to those characteristics is outstanding leadership, resulting in:

- A powerful sense of shared vision throughout the organization, made manifest daily particularly by management at all levels;
- A strong, unswerving focus on strategy that turns the vision into reality when the vision connects with the workforce;
- Clear, challenging goals for all of the types that stretch people or even “freak them out,” since the gap between goals and current performance offers a powerful learning opportunity;
- Team-based work to develop trust through participation;
- Meaningful measurement of performance, emphasizing the work valued most;
- A culture of commitment and performance among everyone from senior managers to the workers who deal with customers; and
- Good communication, involving straight talk throughout the organization and with stakeholders.

The other common key business excellence criteria reflect that people in high-performing enterprises all seek to deliver results by doing their best for the organization and/or the work teams in which they operate every step of the way. Strategic planning for business excellence can only be effective and relevant if it embraces all the main stakeholders. Vital participants who are not included or are overlooked can quickly become disengaged and unmotivated when they realize that top management has failed to take into account the thinking of front-line employees in forward planning. Beyond the planning stage, strategic deployment should involve a variety of teams. Therefore, considering all aspects of strength, weakness, opportunity, and threat (SWOT) analysis before deployment will minimize oversights, mistakes, and the need for redoing work.

All organizations exist to serve a customer. Customers are real people, not account numbers or enterprise names. Because of this, customer buying decisions are very often made for emotional reasons. It is therefore most important to understand customers, their level of satisfaction, and their opinions of an enterprise, as well as their opinions of its competitors, if the enterprise is to grow and improve its market share. SWOT analysis can also play a role in understanding customers.

It would be easy to think that the measurement and analysis of productivity and quality data simply depend on a series of numbers, as in accounting. However, data collection and analysis are performed by people, not simply by IT or finance departments. Interpretations of information and making of decisions based on those interpretations are done by individuals. Thus, data collection and analysis are important tools to inform managers involved in the strategic planning process of what occurs at the customer interface. Many organizations are automating their data collection. If done correctly, this results in more people being able to access data more quickly for faster, better-informed decision making and customer responsiveness. Data must be relevant and deployed to the end users to enable such responsiveness.

It is interesting to note that 2007 Malcolm Baldrige National Quality Criteria for Business Excellence mentioned the “workforce” as the first factor. Excellent organizations seek to engage, manage, and develop their most important resource. They should also be seeking to align their people with the mission, strategy, and action plans. In high-performing organizations, preventing employee turnover is a focus of top management. Opinion surveys or climate surveys can be a way to uncover pockets of low morale, seek out the root causes, and devise improvement plans. Many high-performing organizations are moving to automate the administrative part of workforce management, thus freeing up managers. Why? So that managers can spend more time with their people.

All key criteria for business excellence have a common thread: a focus on process management. Focusing attention on process management goes a long way toward eliminating the people “blame game.” Finger pointing or blaming others inevitably occurs when management does not see itself as part of the problem. Former US President Bill Clinton said in an interview: “I did not appreciate the power of process until after I left office.” In high-performing organizations, process outputs should: at least meet, if not exceed customer requirements (quality); be produced efficiently (profitability); be competitively superior (competitiveness); and the process cycle time be reduced (productivity).

People work in the system, while managers work on the system to improve it. There is an undisputable interdependency at work: people need people in all organizations. The better they work together (alignment) for the customer, the more successful (profitable) the organization will become.

### **Productivity and Profitability**

The pressure for ever-increasing profits is intense and unrelenting today. And accommodating Wall Street, coping with local competitors and thriving in the global economy make bottom-line efficiency an absolute day-to-day business essential.

But most companies have been squeezing costs and doubling down on productivity-enhancing tools, services, practices and processes for years now. So how can they wring any more excess out of their organizations – even if they’re zealously efficient?



That's a very good question – and the right one to ask, at least from our perspective.

The answer is both simple and complex.

Simple because even though we've been continuously modernizing and streamlining to make things more efficient, the average business is still using old techniques and hasn't yet married its previous gains to all the new opportunities currently available for profitable productivity.

Complex because generating constant productivity growth is hard, and finding the right technology to help isn't always easy.

Our view is that we need to combine the old methods with a new digital model that includes real-time tracking of work. This would provide us with immediate knowledge of who's doing what on a team or in an organization, and where each project actually stands. If we could simply understand the specific things each person is responsible for delivering – and get the information on demand – imagine how far ahead we'd be and how many good – and fast – decisions we could make.

We don't need a lot of technology bells and whistles – or reams and screens of exotic information – to advance productivity further. Email chatter isn't necessary; nor is social dialogue or meeting minutes. Just the state of the deliverables. There's no better way to improve productivity than knowing where it lives and who's performing – and where it's lacking and who's slacking – inside a company.

In the end, if we can successfully combine old and new efficiency approaches, we'll re-define productivity for the 21st century. And from here on out, the new equation for bottom-line improvement should be: Productivity Growth Equals More Profit With Less Effort.

Throughout history – especially modern industrial society – we've seen inefficiency square off against an intense need for more profits with less effort. In almost every case, a cutting-edge collaborative tool or sweeping community process helped boost efficiencies and spread knowledge, while increasing profits and reducing risk.

Let's look at the shipping industry in late 17th century England to see how this worked. Back then, ships and their cargo were insured using the combined expertise of individuals who would regularly congregate at coffee bars on Exchange Alley in London. The terms of each deal would revolve around the collective effort of those in attendance; and they would base each insurance agreement on a variety of factors, including: the shipping routes, the weather, the captains, the commodities being transported, and the ships themselves. Those that chose to become guarantors would sign under the stated terms and become the underwriters.

This loosely structured process was filled with inefficiencies and fraught with risk. And with no market maker for insurance, the captain was apt to pay exorbitant rates.

Edward Lloyd, who ran one of these coffee houses in London, clearly grasped the problems with shipping insurance. To remedy things, he began accumulating and publishing shipping data. The posted information started attracting the best and brightest minds in the shipping business. Soon, a group formed Lloyds of London and became a brokerage that guaranteed the investments of their underwriters. Their careful indexing of risk brought rates down and pushed profits up.

This marked the beginning of the end for the inefficiencies that plagued shipping insurance. It also triggered a massive expansion in shipping, because unfettered access to data enhanced visibility and transparency, and this, in turn, reduced insurance risk.

Now let's fast forward approximately 300 years, to the fledgling financial markets in America. Industry was thriving, and investing in railroads, oil and manufacturing was a rich man's endeavor. Less than 5 percent of Americans were invested in company stocks, and to buy equities was a time-consuming and expensive effort.

Over the course of the 20th century, groups of brokers, analysts and experts formed firms and began advising investors based on their know-how and observations. The firms basically operated in staccato

interactions with their clients. There was no continuous data flow, and no real-time monitoring of the markets.

The advent of mutual funds brought more ongoing research and more investors to the financial markets. But significant inefficiencies still remained.

The rise of electronic stock exchanges has begun erasing those inefficiencies. Interactive online tools are putting real-time data, analysis and control in the hands of an ever-broader swath of investors. And, at all times, investors can see the specific performance of every component of their stocks – right down to the minute-by-minute moves of each share. This new technology, combined with Wall Street's advice, expertise and recommendations, empowers investors, puts them on equal footing with brokers, and allows them to make better portfolio decisions more expeditiously.

The result is greater market efficiencies, increased market participation and trading volume, cheaper trades, and a more profitable Wall Street.

Work efficiency will surge in companies around the world when real-time tracking of deliverables – the equivalent of Edward Lloyd's publication of aggregated shipping insurance data and the rise of electronic stock exchanges that provide investors with access to an abundance of on-demand financial data – is finally embraced.

Looking to the future, we'll be able to stimulate even more efficiency and productivity if we develop and deploy technology that tracks deliverables in real-time both inside and outside a company. Imagine, for example, if we had visibility into all the tasks that a company's vendors and service providers were responsible for. And what if we could eventually extend that real-time deliverable tracking all the way down the supply chain to vendors and service providers who are several steps removed from the company itself.

Each new ripple of technology that allows us to instantly see who owns the work, who is doing the work, and how well the work is actually being done, will reinforce accountability. And accountability is a powerful driver when it comes to productivity and profitability.

The bottom line is that the next big surge of work productivity in the 21st century will depend on a simple digital metric that measures, monitors and manages ownership of critical tasks in real-time.

### 6.3 BALANCED SCORE CARD

The Balanced Scorecard was developed in the early 1990s by two guys at the Harvard Business School: Robert Kaplan and David Norton. The key problem that Kaplan and Norton identified in the business of the day was that many companies tended to manage their businesses based solely on financial measures. While that may have worked well in the past, the pace of business in today's world requires more comprehensive measures. Though financial measures are necessary, they can only report what has happened in the past — where a business has been, but not where it is headed. It's like driving a car by looking in the rearview mirror.

To provide a management system that was better at dealing with today's business pace and to provide business managers with the information they need to make better decisions, Kaplan and Norton developed the Balanced Scorecard.

Note that the Balanced Scorecard is a *management system* — not a *measurement system*. Yes, measurement is a key aspect of the Balanced Scorecard, but it is much more than just measurement; it is a means to setting and achieving the strategic goals and objectives for your organization.

A method of implementing a business strategy by translating it into a set of performance measures derived from strategic goals that allocate rewards to executives and managers based on their success at meeting or exceeding the performance measures is known as Balance Scorecard. It is a strategic planning and management system that is used extensively in business and industry, Government,



and nonprofit organizations worldwide to align business activities to the vision and strategy of the organization, improve internal and external communications, and monitor organization performance against strategic goals. It was originated by Drs. Robert Kaplan and David Norton as a performance measurement framework that added strategic non-financial performance measures to traditional financial metrics to give managers and executives a more 'balanced' view of organizational performance. While the phrase Balanced Scorecard was coined in the early 1990s, the roots of this type of approach are deep, and include the pioneering work of General Electric on performance measurement reporting in the 1950's and the work of French process engineers (who created the Tableau de Bord – literally, a “dashboard” of performance measures) in the early part of the 20th century.

The Balanced Scorecard has evolved from its early use as a simple performance measurement framework to a full strategic planning and management system. The “new” Balanced Scorecard transforms an organization's strategic plan from an attractive but passive document into the “marching orders” for the organization on a daily basis. It provides a framework that not only provides performance measurements, but helps planners identify what should be done and measured. It enables executives to truly execute their strategies.

Recognizing some of the weaknesses and vagueness of previous management approaches, the Balanced Scorecard approach provides a clear prescription as to what companies should measure in order to 'balance' the financial perspective. The Balanced Scorecard is a management system (not only a measurement system) that enables organizations to clarify their vision and strategy and translate them into action. It provides feedback around both the internal business processes and external outcomes in order to continuously improve strategic performance and results. When fully deployed, the Balanced Scorecard transforms strategic planning from an academic exercise into the nerve centre of an enterprise.

### 6.3.1 Perspectives

The Balanced Scorecard suggests that we view the organization from four perspectives, and to develop metrics, collect data and analyze it relative to each of the following perspectives:

**The Learning & Growth Perspective:** This perspective includes employee training and corporate cultural attitudes related to both individual and corporate self-improvement. In a knowledge worker organization, people, the only repository of knowledge, are the main resource. In the current climate of rapid technological change, it is becoming necessary for knowledge workers to be in a continuous learning mode. Metrics can be put into place to guide managers in focusing training funds where they can help the most. In any case, learning and growth constitute the essential foundation for success of any knowledge worker organization.

Kaplan and Norton emphasize that 'learning' is more than 'training'; it also includes things like mentors and tutors within the organization, as well as that ease of communication among workers that allows them to readily get help on a problem when it is needed. It also includes technological tools; what the Baldrige criteria call “high performance work systems.”

**The Business Process Perspective:** This perspective refers to internal business processes. Metrics based on this perspective allow the managers to know how well their business is running, and whether its products and services conform to customer requirements (the mission). These metrics have to be carefully designed by those who know these processes most intimately; with our unique missions these are not something that can be developed by outside consultants.

**The Customer Perspective:** Recent management philosophy has shown an increasing realization of the importance of customer focus and customer satisfaction in any business. These are leading indicators. If customers are not satisfied, they will eventually find other suppliers that will meet their needs. Poor performance from this perspective is thus a leading indicator of future decline, even though the current financial picture may look good.

In developing metrics for satisfaction, customers should be analyzed in terms of kinds of customers and the kinds of processes for which we are providing a product or service to those customer groups.

**The Financial Perspective:** Kaplan and Norton do not disregard the traditional need for financial data. Timely and accurate funding data will always be a priority, and managers will do whatever necessary to provide it. In fact, often there is more than enough handling and processing of financial data. With the implementation of a corporate database, it is hoped that more of the processing can be centralized and automated. But the point is that the current emphasis on financials leads to the “unbalanced” situation with regard to other perspectives. There is perhaps a need to include additional financial-related data, such as risk assessment and cost-benefit data, in this category.

**6.3.2 Suggested Balanced Scorecard - Pro Forma for Hotel Industry**

Perspective	Key Performance Indicator	Target	Actual	Deviation
Customers	Online Customer Rating Level	A	B	C%
	Customer Satisfaction Score	A	B	C%
	Number Of Customer Complaints	A	B	C%
	Percentage Repeat Customers	A	B	C%
Shareholder	Gross Revenue Per Bedroom	A	B	C%
	Average Spend Per Guest	A	B	C%
	Gross/Net Margin	A	B	C%
	Return On Investment	A	B	C%
Internal Business Process	Average Check-In/Out Times	A	B	C%
	Average Time To Service One Room	A	B	C%
	Average Bar Service Time	A	B	C%
	Average Restaurant Service Time	A	B	C%
Learning & Innovation	New Services Offered	A	B	C%
	Training And Development Spend	A	B	C%
	Capital/Infrastructural Expenditure	A	B	C%
	Number Of Internal Promotions	A	B	C%

**6.3.3 The Balanced Scorecard implementation process is quite simple insofar as it involves**

- (i) Agreeing a set of performance measures to be agreed per perspective
- (ii) Agreeing performance targets for each measure
- (iii) Recording actual performance for each performance measure
- (iv) Regularly reporting and acting on any performance deviation

**The benefits of adopting a Balanced Scorecard approach to performance management may include:**

- (1) It creates a longer term strategic view of performance rather than a myopic short term view.
- (2) It broadens the view of divisional managers as to what represents good performance away from a solely financially orientated view.
- (3) Organisations can develop performance measures that are explicitly aligned to the corporate strategy and in support thereof.
- (4) It considers customer viewpoint which is critical in any business.
- (5) It helps to promote accountability as each performance measure could be the responsibility of a nominated individual or individuals.

### 6.3.4 The implementation of the Balanced Scorecard should be relatively simple and understandable.

The Balanced Scorecard is not a piece of software. Unfortunately, many people believe that implementing software amounts to implementing a Balanced Scorecard. Once a scorecard has been developed and implemented, however, performance management software can be used to get the right performance information to the right people at the right time. Automation adds structure and discipline to implementing the Balanced Scorecard system, helps to transform disparate corporate data into information and knowledge, and helps communicate performance information.

So, what is the Balanced Scorecard? In short, it's a management system that enables your organization to set, track, and achieve its key business strategies and objectives. After the business strategies are developed, they are deployed and tracked through *the Four Legs of the Balanced Scorecard*. These four legs comprise four distinct business perspectives: The Customer Leg, the Financial Leg, the Internal Business Process Leg, and the Knowledge, Education, and Growth Leg. These four legs of the Balanced Scorecard are necessary for today's business executives and managers to be able to plan, implement, and achieve their business strategies:

- **Customer Leg:** Measures your customers' satisfaction and their performance requirements — for your organization and what it delivers, whether it's products or services.
- **Financial Leg:** Tracks your financial requirements and performance.
- **Internal Business Process Leg:** Measures your critical-to-customer process requirements and measures.
- **Knowledge, Education, and Growth Leg:** Focuses on how you educate your employees, how you gain and capture your knowledge, and how you use it to maintain a competitive edge within your markets.

These four legs have to be measured, analyzed, and improved together — continuously — in order for your business to thrive. If you ignore any one of these four legs, it'll be like sitting on a four-legged stool with a broken leg. You'll eventually lose your balance and fall flat on your face. And lying flat on your face is no way to run a business!

You not only have to measure these critical four legs, but also set strategies, goals, objectives, and tactics to make them happen. And while you're at it, you have to make sure that your strategies and tactics are congruent. They have to work together and create a single thread, tying together in ways that make sense. This isn't an optional exercise; it's essential. The future of your business depends on it.

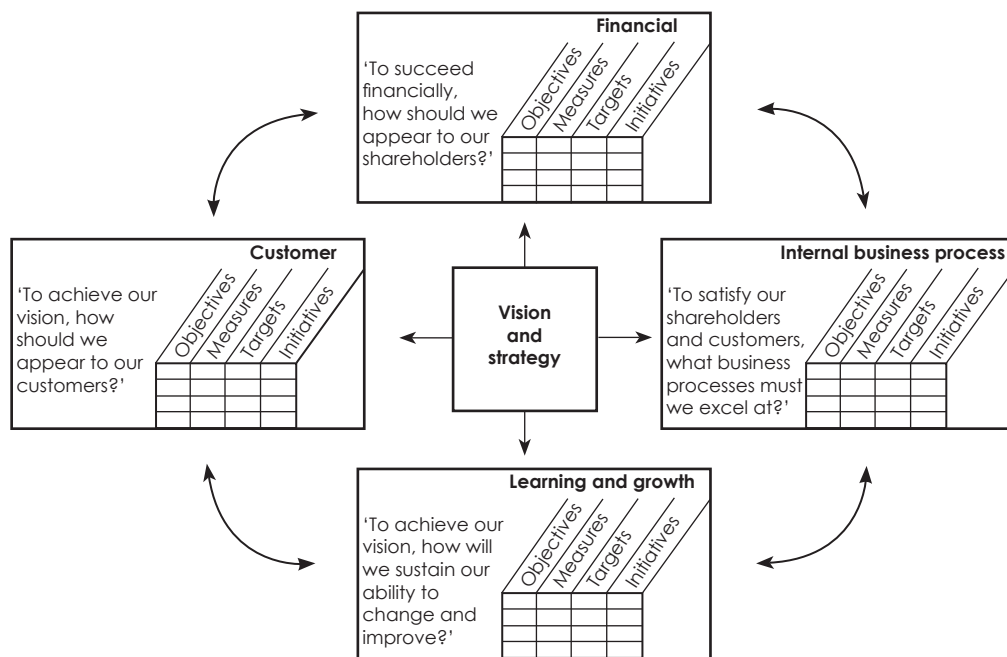

**Fig : Four Perspective of Balance Score Card**



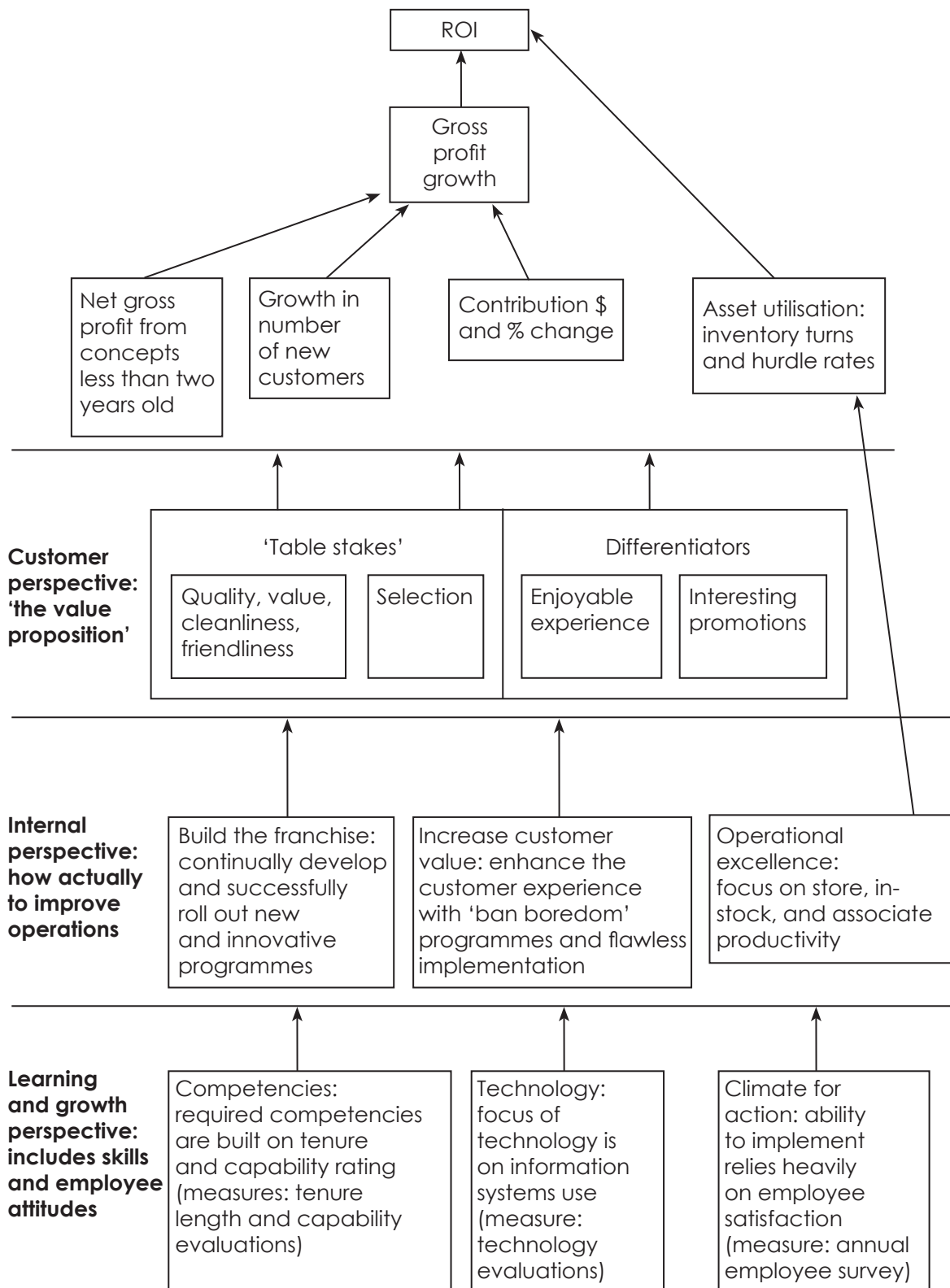

Fig : Example of a strategy map and some balanced measures



---

## **Section B**

# **IT & Econometric Tool in Performance Management**

---





# Study Note - 7

## APPLICATION OF IT AND ECONOMETRIC TOOLS IN PERFORMANCE MANAGEMENT



### This Study Note includes

- 7.1 Impact of Developments in Information Technology and E-Commerce
- 7.2 Data Availability, Data Envelopment Analysis(DEA), Data Mining (DM) & Data Quality
- 7.3 Artificial Neural Network (ANN)
- 7.4 Six Sigma
- 7.5 Statistical Quality Control (SQC)
- 7.6 Stochastic Frontier Analysis (SFA), Fuzzy Sets Theory (FST) & Malm Quist Index (MI)
- 7.7 Principal Component Analysis (PCA)
- 7.8 Total Productivity Management (TPM)
- 7.9 Supply Chain Management (SCM)
- 7.10 Software Tools (Spread Sheets to BI Application)
- 7.11 Different Resources of Technology - Data Warehouse, Business Intelligence System
- 7.12 Scorecards and Dashboard, Decision Support Systems, Management Information Systems, OLAP - Online Analytical Processing Tools

### 7.1 IMPACTS OF DEVELOPMENTS IN INFORMATION TECHNOLOGY AND E-COMMERCE

Electronic commerce may have large economic effects in the future. Internet commerce will change the face of business forever. The e-commerce has affected the global economy in many different ways.

First of all, it has affected the information technology, and all the economic sectors, all and above e-commerce has enhanced the productivity growth worldwide and this impact will be discussed. Advancing the Internet revolution is more than ever a key public policy goal.

#### 7.1.1 E-commerce

It is clear that E-commerce is a very broad concept and does not have a clear cut definition. One way of defining it, is that, it is a way of doing business transactions via the internet. E-commerce or E-business is based on the electronic processing and transmission of data, including text, sound, and video.

E-commerce as it is commonly known is the use of technology to conduct financial transactions online. E-commerce can occur within and between three basic participant groups – business, government, and individuals.

#### 7.1.2 E-commerce Market Models

##### (i) Business to Business (B2B)

Business to Business or B2B refers to e-commerce activities between businesses. These transactions are usually carried out through Electronic Data Interchange or EDI. This allows more transparency among business involved; therefore business can run more efficiently.

**(ii) Business to Customer (B2C)**

Business to Customer or B2C refers to e-commerce activities that are focused on consumers rather than on businesses.

**(iii) Customer to Business (C2B)**

Customer to Business or C2B refers to e-commerce activities, which uses reverse pricing models where the customer determines the prices of the product or services. There is increased emphasis on customer empowerment.

**(iv) Customer to Customer (C2C)**

Customer to Customer or C2C refers to e-commerce activities, which uses an auction style model. This model consists of person-to-person a transaction that completely excludes businesses from the equation.

**7.1.3 Issues Affecting the Development of E-commerce**

There are a number of issues affecting e-commerce which are:

- (i) Taxation
- (ii) Security
- (iii) Privacy
- (iv) Profitability
- (v) Content
- (vi) Participation in new international standards development

**7.1.4 Technical and Operational Factors of E-commerce**

**(i) Protocol (Standards) Making Process**

A well-established telecommunications and Internet infrastructure provides many of the necessary building blocks for development of a successful and vibrant e-commerce marketplace.

**(ii) Delivery Infrastructure**

Successful e-commerce requires a reliable system to deliver goods to the business or private customer.

**(iii) Availability of Payment Mechanisms**

Secure forms of payment in e-commerce transactions include credit cards, checks, debit cards, wire transfer and cash on delivery.

**(iv) General Business Laws**

The application of general business laws to the Internet will serve to promote consumer protection by insuring the average consumer that the Internet is not a place where the consumer is a helpless victim.

**(v) Public Attitude to E-commerce**

The public attitude toward using e-commerce in daily life is a significant factor in the success of e-commerce.

**(vi) Business Attitude to E-commerce**

The willingness of companies to move away from traditional ways of doing business and develop methods and models that include e-commerce is essential.



### 7.1.5 E-commerce and the Economy

The electronic economy will force change within nation states. The modern nation state remains the most prevalent unit of governance in the developed and the developing world. The concept has, in the last 50 years, been extended rather than retracted. There are now more than 200 hugely different nation states, with different legal and regulatory systems, existing in the world. In this context, we define a nation state as a coherent territory circumscribed by defined borders over which the single national government has legitimate jurisdiction. During its 200 year history, the nation state has endured many changes. However, the advent of the electronic economy is confronting the nation state, with intimations of a future in which its relevance to its citizens and enterprises will be challenged. The apparatus of economic regulations and taxation through which nation states operate was developed to support and facilitate industrial economy. That economy produces tangible and location bound services that are sold and distributed within and between fixed borders. In that familiar world of national and international trade, nation states have a variety of tools at their disposal to achieve their economic ends.

They can levy tariffs on imports, raise taxes, protect consumers rights, punish economic criminals, set commercial standards, and provide guarantees of monetary payment. Until recently, these tools were supported by governments majority control over communications networks and information dissemination. Because of the emergence of global communications networks, the nation state is gradually losing monopoly control of information and financial flows. Private individuals and enterprises and groups now have the ability to source, package, and transmit information in compressed time and space. Through "digitization" currency, services, and even some goods can be conveyed immediately, transacted invisibly across the globe. Interactive networks are creating a new, network-linked world without borders, in which many commercial transactions are beyond the reach of national jurisdictions, laws, and taxation systems. As a result, many of the economic instruments and processes of the nation state need to be reexamined in the light of these new challenges.

### 7.1.6 The Global Economy and E-commerce: An Overview

It was claimed that, between 1994 and 1998, the information and communications industries had lowered US and UK inflation by 0.5% a year and would increase sustainable growth by 0.5% a year over the next decade<sup>8</sup>. In 1999, companies invested \$280 million in e-commerce infrastructure and Internet presence and venture capitalists in the U.S. risked \$32 billion in web-based businesses. Total Internet purchases in 1999 were estimated at \$130 billion and it was believed that it will reach \$2.5 trillion by 2004.

In the short term, e-commerce and advertising revenues will remain largely within the United States. By 2003, the U.S. will retain more than half of all e-commerce revenue, with Europe representing about a third. The U.S. accounted for 85 % of all online ad revenues in 2002 according to Forrester Research, and will keep more than two-thirds through 2004. As a multi-national organization, the European Union illustrates the idea that while the Internet is borderless and global, local conditions matter to the success of e-commerce. The key factors which will lead to significant growth in e-commerce are the adoption of the Euro as the single unit of currency, the continued liberalization of telecommunications infrastructure throughout the Union and the increased use of the Internet. By most estimation used, we found that over 95% e-commerce takes place in developed countries, with Africa and Latin America combined accounting for less than 1% of the total. Business to business (B2B) transactions represents around 95% of all e-commerce transactions worldwide.

### 7.1.7 The E-commerce Strategy

It may be useful for development organizations to consider the many issues involved before embarking on an e-commerce initiative, in relation to the organization's mandate, development goals, and organizational structure. The primary issues involved would include:

- **Resource Expansion** -- Is the main goal of selling goods and services online the generation of revenue to offset operational costs? If so, how much revenue does the organization expect/wish

to generate? These strategic questions will allow the organization to assess how much funding will go toward e-commerce activities. If the organization is approaching e-commerce as a means of covering not only the costs of producing the goods and services and disseminating development-focused products, but wishes to expand its revenue base to support other project costs, then it may want to develop an e-commerce platform and strategy that can attract customers. The organization may have to approach e-commerce as a resource expansion activity that uses business strategies and a full marketing approach. This leads to the question of whether this fits in with the development mandate of the organization and its charitable organization status. Will e-commerce activities distort the tax-free status of the development organization? Is the organization liable in the case of legal conflicts? Most development organizations have already faced these questions if they sell publications and other products by "traditional" means.

- **Capital Costs** -- How much funding is the organization willing to put into e-commerce activities? E-commerce platforms can be high priced, depending on the level of sophistication. A development organization undertaking e-commerce activities should consider whether it wants to incur higher costs, with the possibility of cost recovery from an expected higher level of sales. What are the possibilities of receiving financial assistance from donor agencies or partner organizations for this activity? Development organizations pursuing e-commerce activities may have to decide between a variety of options for their online selling activities, depending on their financial capacities. These options can be divided into 1) technical hardware and 2) site design and maintenance. The organization will have to decide whether it wants to invest in setting up its own in-house server, depending on the organization's size and computing requirements, or find a third party that is willing to host the site on its server. Is the third party another development-focused organization, or is it a private company/ISP? Regarding design and maintenance of the e-commerce site, is the organization able to hire in-house technical personnel to handle design, development, and maintenance, or is it more cost effective to hire an outside party to handle these tasks? Developing an e-commerce site that generates high levels of revenue will have to respond to the changes in e-commerce platforms in the commercial sector. The development organization may want to consider using security encryption software for credit card payment, increasing costs to an extent yet benefiting from increasing customer confidence in the transaction process. Will the site be eye-catching, with the hope of attracting customers, possibly increasing site development costs for higher level graphics and design? Pan Partners currently do not have to bear all of the above-mentioned capital costs, but may one day have to consider them when they initiate an e-commerce site on their own.
- **Staffing/Training** -- Along with the capital costs comes the assessment of whether the organization has trained staff that can maintain an e-commerce site, including both the technical staff mentioned above, and the administrative staff that can process and fulfil the orders. Is the current staff able and willing to take on these activities? Will capacities be taken away from other projects and activities? Will the organization have to employ new staff to concentrate on e-commerce? Would it be cheaper/more effective to hire an outside company to do this? Can the organization afford these costs? Will the staff have to receive training? All of the above questions are important, not only for the success of the e-commerce initiative, but also to ensure that capacities are not taken away from other development activities. Once the above-mentioned issues are addressed, it is possible to move on to the operational strategy. The operational strategy addresses the issues highlighted in the examples above. These issues are important to address because of their impact on the overall expected sales patterns of development organizations.
- **Marketing** -- As evident from the discussion above, a good marketing strategy forms the basis of the operational strategy, in order to attract customers to the e-commerce site and ensure a steady pattern of sales. Development organizations often need not employ capital-intensive marketing programs in order to have a successful marketing campaign. The marketing strategy can be divided into two main categories: 1) online markets and 2) offline markets.



- **Online markets** include those customers that have already used, or are able to use, e-commerce for purchasing products. The Internet can be used as a tool in itself in order to capture online markets. Techniques include identifying other sites that would be willing to link to the organization's e-commerce site, or cross selling on these sites. These sites include organization partners and sites that offer links to development information and online resources. Another technique includes identifying target markets that would be interested in purchasing the specific development-focused products that the organization is selling online. Once the target markets are identified, potential customers can be identified and a personalized e-mail sent, providing a description of the products being offered and why they might be of interest to the potential customer. As well, individuals and organizations that have already been in contact with the organization can be contacted by e-mail with a similar message. In this way, the development organization is targeting markets that it knows will be interested in the products it offers.
- **Offline markets** include those individuals and organizations that have access to the Internet, but have never used e-commerce or are unlikely to do so. In these cases, "traditional" means of marketing can be employed to attract the potential customer to the e-commerce site. This includes advertisements in publications, newsletters, announcements at conferences and events, mailings to members, and supporters. Other innovative means of marketing can be employed, such as advertising promotional offers (e.g., "buy one, get one free," or announcements of discounted items) on the home page of the development organization's website.
- **Types of Products Offered for Sale Online** -- As previously noted, the products that are produced by development organizations primarily serve the purpose of disseminating information on a specific development topic or issue. These are products that are not often produced for mass markets, but for particular groups with an interest in the development sector. Should development organizations wish to broaden their market sector, they can develop products that have a wider appeal, while still maintaining a focus on the dissemination of information on development issues. These products could include general information and educational publications on a particular development theme (e.g., a survey of regional environmental issues). Such products could draw in new markets, such as schools and libraries. Development organizations could also look at innovative ways of using the Internet to create Web-based products for sale. For example, electronic versions of books and journals can provide a low-cost means of both producing these products and distributing them. Text can be digitized and offered for sale online. The product can then be sent to the customer electronically, cutting down on the cost of printing the text and sending the item by post. Other products could include digitized audio and video materials and electronic greeting cards. One such initiative is E-cards, an online greeting card company that supports the World Wildlife Fund (WWF). The virtual cards contain photographs of endangered animals and habitats. The site is sponsored by advertisers and for every greeting card sent, E-cards donates a significant portion of the revenue to the WWF. It also assists by sending Web traffic to the WWF website and, as an extension, drawing attention to the cause of endangered species and the environment. Another possibility that development organizations could pursue is allowing charitable donations and contributions to be made online. This would allow individuals that would like to support the efforts of a particular organization to submit their contribution in the form of an online transaction. This may increase overall contributions, as it provides a convenient way for individuals with access to the Internet to donate.
- **Purchasing Patterns of Online Customers** -- The frequency of updating new products can impact the number of items purchased by customers and the number of returning customers. In order to encourage customers to purchase more than one item at a time, it is important to offer a (wide) variety of products. Returning to the marketing strategies, development organizations can offer sales promotions mentioned above. This can increase the per-customer volume of sales, increasing overall revenue. Development organizations can consider organizing a schedule for updating their e-commerce site, adding new products and promotional offers on a regular basis. This way, previous customers will see that new products are available for sale and may be



attracted to purchasing a second or third time. It may be useful to form a general profile of who the organization's likely customers might be, and what their purchasing patterns could be. Are they individuals, companies, research institutes, universities, donors, libraries, or governments? Further research on e-commerce customers could provide a useful tool for assessing online purchasing patterns. Developing an e-commerce strategy can allow development organizations to approach this initiative with an understanding of what they want to achieve and how to achieve it. This can encourage strategic thinking of how to attract potential customers to the site and how to keep them returning. In order for e-commerce initiatives to be successful, whether generating revenue to offset production costs or increasing overall revenue to offset operational costs, development organizations can often use business strategies to more effectively achieve their overall goals.

### **7.1.8 Indian Context**

The use of E-commerce started around two decades ago with the invention of technology such as electronic fund transfers. Introduction of electronic data interchange extended it to producers, retail traders and other services. Its use kept on spreading in many different areas such as stock market operations, travel reservations etc.

The term 'E-commerce' has come out of the term 'e-mail' which means doing online business with the help of computer, e-mail, fax, and telephone lines. In 1972, IBM used the term 'e-commerce and with the invention of computers in 1973 the first successful transaction was carried out between USA and European Union. In the 1990's we witnessed commercialization of internet, and growing popularity of the term e-commerce. Increasing mobile penetration is further expanding the scope and size of e-commerce.

According to the Internet and Mobile Association of India (IAMAI), the Indian online retail market is expected to grow at the rate of 47% in 2011 and will reach ₹ 46, 000 crores.

### **7.1.9 Role of Government**

Government can, however, play an important role in examining the economic and social impact of e-commerce technologies and in promoting understanding and application of these technologies throughout Indian industries and communities.

- (i) Facilitating market access and business opportunities, especially for small, medium, and micro enterprises (SMMEs), on a national and global scale.
- (ii) Providing educational and skills development resources.
- (iii) Supporting the rapid deployment of necessary infrastructure.
- (iv) Facilitating the development of MPCs as vibrant seeding points for community knowledge and wealth creation, above and beyond the provision of the latest ICTs.
- (v) Developing "model use" programmes for the dissemination of government information and services using e-commerce platforms, e.g., for electronic tender processes.
- (vi) Supporting necessary transitions in the laborforce due to technological and industrial transformation.
- (vii) Ensuring equity in the availability of opportunities and benefits, in the context of the overall development of Indian rural community.

### **7.1.10 Economic Impacts**

- (i) Governments and especially businesses are confronted with an "adapt or die" scenario, particularly in developing countries, to fall behind in technology and innovation could increase the gap with wealthier, more advanced economies.
- (ii) E-commerce presents unique opportunities for less developed countries to greatly expand their markets, both internally and externally. Externally, the Internet and other technologies may allow for low-cost international trade, even for small, local businesses. Internally, many groups of citizens



who had been considered “marginalized” and “unbanked” may gain affordable access to financial services, and may thus participate more readily in all aspects of the economy.

- (iii) Rural areas considered too costly or unprofitable for business development might increasingly become a focus for investment and market expansion, and also for relocating corporate offices.
- (iv) Development of microfinance institutions to provide financial services to the semi urban and rural areas.
- (v) E-learning and M-learning enhances the access of the educational institutions in remote areas.
- (vi) E-governance initiatives increases access to information and thereby reducing corruption.
- (vii) M-banking (Mobile banking) reduces the transaction cost of banking industry thereby increasing access to financial services through rapidly growing mobile market.
- (viii) Micro, small and medium enterprises can leverage the technology to market their products globally.

#### **7.1.11 Social Impacts:**

- (i) Some of the intangible downside risks of increasingly “virtual” interaction within rural community include the possible “de-socialization” of individuals who have less and less direct contact with their peers, their co-workers, and their community. This can extend to family relations as well, particularly if technology creates further imbalances between those who are “on-line”, and those without access to these technologies. On the other hand, equitable deployment of infrastructure and educational resources could provide a means of maintaining and expanding family and communal ties that would otherwise be broken by distance and cost.
- (ii) Other problem includes psychological and physical health-related effects of sedentary, computer anchored work environments. Early experience suggests that as this type of work (and social) activity expands, businesses and government will have to consider broad-based means to offset health hazards with new policies and treatments.
- (iii) E-commerce may offer the potential for shifting the balance of opportunity, wealth, and social and political inclusion. As much as these trends can be beneficial to the majority of rural community, they are also likely to bring unanticipated effects on cultural and social norms. Indigenous traditions that have so far survived the intrusion of modernity may be less resilient in the face of global networks and instantaneous communication. These types of impact are just as significant as changes in bottom-line incomes, and can really only be “measured” by the persons whose lives are being changed by forces largely beyond their control.
- (iv) Supporting MSMEs: Electronic commerce opportunities are valuable for giant corporations and small entrepreneurs alike. In the latter case, however, the technologies and market options available through e-commerce may foster a true revolution in the way business structures and relationships are organized. The prospect of establishing new micro, small, and medium enterprises (SMMEs) is greatly enhanced by the efficiencies available through information and communications technologies. A study by Google India showed that 57% of SME's used website as a sales channel and got direct leads from their websites. According to Internet and Mobile Association of India 73% of MSME's have their own websites. Importantly 99% of MSME's use online B2B market places to generate business.

#### **7.1.12 The Brand 'India'**

India is a developing country that entered the IT revolution several years ago. From low-end data entry type operations to Y2K solution providers, the expertise and business has converted itself into a US\$ 6 billion industry. Bangalore (and recently Cyberabad) have become buzz-words in the IT world. Today the country is seeking to emerge as a major e-commerce powerhouse in Asia. How did India do this and what else does it need to do to maintain the momentum?

India Inc. has established itself as a major global IT brand. This phenomenal growth has not been achieved overnight. The Compounded Annual Growth Rate (CAGR) for the Indian software industry revenues between 1995 to 2000 has been 56.3 per cent and its software professionals are the envy of countries across the globe. And yet on several indicators the figures are contra-indicatory to this success. In IT, India is a country of extremes. While on the one hand there is a booming software industry, on the other hand there exists an underdeveloped and unreliable communications infrastructure and low local Internet connectivity.

**In spite of this the following negatives are :**

- 70 per cent of the population belongs to the rural areas where the majority lack basic amenities
- 14<sup>th</sup> largest telecom network in the world, though 67 per cent of its villages do not yet have telephones
- PC penetration ratio of 3 per thousand against 460 per thousand for developed countries
- Internet connections of less than a million today, with on-line population of 0.4 per cent only.

But,

- Goldman Sachs says that by 2003, 70 million Indians will be on the Net.
- Led by export growth of over 50 per cent over the last few years, the Indian software industry has emerged as a leader
- Software exports increased from \$ 15 million in 1987-88 to \$5.7 billion in 1999–2000. and Japan for 3.5 per cent
- Indians account for 34 per cent of all Microsoft employees, 28 per cent of IBM, and 17 per cent of Intel employees
- The Industry and Government have set a target for 2008 to position India as a leading software force with \$50 billion in revenue and an additional \$20 billion from IT enabled services
- NASSCOM has predicted a \$10 billion e-business by 2004
- Today, the Indian software industry employs 280,000 people and every year over 60,000 professionals join. A McKinsey study shows an employment potential of over 2 million in this industry by the end of the decade.

Despite these high growth rates, India's share in the world software product market is still very low, though India still enjoys an advantage over many other nations in software development, services, and exports. This is partially due to the fact that India possesses the world's second largest pool of scientific manpower, which is also English speaking. Coupled with the fact that the quality of Indian software is considered to be good at relatively low cost, it makes for a definitive competitive advantage in the global software economy.

It would be of interest to analyse some of the main initiatives and experiences in India that led to its emergence as a major software exporting nation.

There is a distinct shift taking place in India today in the form of the industry response to the digital economy. As mentioned earlier, from the low end and back end software jobs that were mostly IBM main-frame software projects and body-shopping services provided to US companies, the three major areas of IT services export that are emerging now are e-commerce software and services, Web-enabled services, and e-business and e-trade transactions and services.

## 7.2 DATA AVAILABILITY, DATA ENVELOPMENT ANALYSIS(DEA), DATA MINING (DM) & DATA QUALITY

### 7.2.1 Data Availability

Data availability is a term used by some computer storage manufacturers and storage service providers (SSPs) to describe products and services that ensure that data continues to be available at a required level of performance in situations ranging from normal through “disastrous.” In general, data availability is achieved through redundancy involving where the data is stored and how it can be reached. Some vendors describe the need to have a data center and a storage-centric rather than a server-centric philosophy and environment.

In large enterprise computer systems, computers typically access data over high-speed optical fiber connection to storage devices. Among the best-known systems for access are ESCON and Fibre Channel. Storage devices often are controlled as a redundant array of independent disks (RAID). Flexibility for adding and reconfiguring a storage system as well as automatically switching to a backup or failover environment is provided by a programmable or manually-controlled switch generally known as a director.

Two increasingly popular approaches to providing data availability are the storage area network (SAN) and network-attached storage (NAS). Data availability can be measured in terms of how often the data is available (one vendor promises 99.999 per cent availability) and how much data can flow at a time (the same vendor promises 3200 megabytes per second).

### 7.2.2 Data Envelopment Analysis (DEA)

DEA is today one of the most successful methods of operational research with a wide range of applications and an extensive bibliography is available (Giokas & Pentzaropoulos 2000). For instance, Emrouznejad, Parker, and Tavares (2008), in their extensive searches, have identified more than 4000 research articles published in journals or book chapters. They also enlightened that the evolution of DEA as a worldwide accepted operations research / management science tool and has been tracked in terms of the increases of publications and applications. The results of DEA are relative performance measures. With respect to the efficiency frontier, which is built by the efficient DMUs, the amount of improvement required for the inefficient DMUs are determined. The flexibility of DEA has been demonstrated successfully in numerous performance appraisals in real environments.

- Assess the performance of police forces in England and Wales (Thanassoulis 1995)
- Performance appraisal of engineering design personnel (Paradi, et al. 2002)
- Performance appraisal of primary care physicians (Wagner, Shimshak & Novak 2003)

This is a nonparametric method in operations research and economics for the estimation of production frontiers. It is used to empirically measure productive efficiency of decision making units (or DMUs). Non-parametric approaches have the benefit of not assuming a particular functional form/shape for the frontier, however they do not provide a general relationship (equation) relating output and input. There are also parametric approaches which are used for the estimation of production frontiers (see Lovell & Schmidt 1988 for an early survey). These require that the shape of the frontier be guessed beforehand by specifying a particular function relating output to input. One can also combine the relative strengths from each of these approaches in a hybrid method (Tofallis, 2001) where the frontier units are first identified by DEA and then a smooth surface is fitted to these. This allows a best-practice relationship between multiple outputs and multiple inputs to be estimated.

“The framework has been adapted from multi-input, multi-output production functions and applied in many industries. DEA develops a function whose form is determined by the most efficient producers. This method differs from the Ordinary Least Squares (OLS) statistical technique that bases comparisons relative to an average producer. Like Stochastic Frontier Analysis (SFA), DEA identifies a “frontier” on which the relative performance of all utilities in the sample can be compared: DEA benchmarks firms only against the best producers. It can be characterized as an extreme point method that assumes that if a firm can produce a certain level of output utilizing specific input levels, another firm of equal

scale should be capable of doing the same. The most efficient producers can form a 'composite producer', allowing the computation of an efficient solution for every level of input or output. Where there is no actual corresponding firm, 'virtual producers' are identified to make comparisons"

Data envelopment analysis (DEA) is a linear programming methodology to measure the efficiency of multiple decision-making units (DMUs) when the production process presents a structure of multiple inputs and outputs.

"DEA has been used for both production and cost data. Utilizing the selected variables, such as unit cost and output, DEA software searches for the points with the lowest unit cost for any given output, connecting those points to form the efficiency frontier. Any company not on the frontier is considered inefficient. A numerical coefficient is given to each firm, defining its relative efficiency. Different variables that could be used to establish the efficiency frontier are: number of employees, service quality, environmental safety, and fuel consumption. An early survey of studies of electricity distribution companies identified more than thirty DEA analyses—indicating widespread application of this technique to that network industry. (Jamasp, T. J., Pollitt, M. G. 2001). A number of studies using this technique have been published for water utilities. The main advantage to this method is its ability to accommodate a multiplicity of inputs and outputs. It is also useful because it takes into consideration returns to scale in calculating efficiency, allowing for the concept of increasing or decreasing efficiency based on size and output levels. A drawback of this technique is that model specification and inclusion/exclusion of variables can affect the results." (Berg 2010)

**Some of the Advantages of DEA are:**

- no need to explicitly specify a mathematical form for the production function.
- proven to be useful in uncovering relationships that remain hidden for other methodologies.
- capable of handling multiple inputs and outputs.
- capable of being used with any input-output measurement.
- the sources of inefficiency can be analysed and quantified for every evaluated unit.

**Some of the Disadvantages of DEA are:**

- results are sensitive to the selection of inputs and outputs (Berg 2010).
- you cannot test for the best specification (Berg 2010).
- the number of efficient firms on the frontier tends to increase with the number of inputs and output variables (Berg 2010).

DEA measures efficiency by estimating an empirical production function, which represents the highest values of outputs that could be generated by relevant inputs, as obtained from observed and input output vectors for the analysed Decision Making Units (DMU). The efficiency of a DMU is then measured by the distance from the point representing its input and output values to the corresponding reference point on the production function (Mohamed & Luc 2008). DEA defines the relative efficiency for each DMU (bank branches, employees in engineering teams, hospitals, schools) by comparing its input and output data to all other DMUs in the same cultural environment. In addition to relative efficiency measures, a DEA study provides the following four properties (Paradi, Smith & Schaffnit-Chatterjee 2002).

- A piecewise linear empirical envelopment surface to represent the best practice frontier, consisting of units which exhibit the highest attainable outputs in relation to all other DMU's in the population, for their given level of inputs.
- An efficiency metric to represent the maximal performance measure for each DMU measured by its distance to the frontier.
- Specific targets or efficient projections onto the frontier for each inefficient DMU.

- An efficient reference set or peer group for each DMU defined by the efficient units closest to the DMU.

DEA is an appropriate method of evaluation of employees. Apart from giving individuals an efficiency score DEA is also able to identify the following five features.

- The efficiency frontier which consists of the best practice units.
- The most and the least efficient units, which are ranked accordingly. The efficiency rating of any unit reflects its distance from the frontier, and it is equal to 1 for all efficient units and is less than 1 for all inefficient units.
- An efficiency reference set, or peer group, for each inefficient unit. This is a subset of all the efficient units closest to the unit under evaluation, it contains the efficient units which have the most similar input output orientation to the inefficient unit, and should, therefore, provide examples of good operating practice for the inefficient unit to emulate.
- Input output target levels for each inefficient unit that would, if reached, make that unit relatively efficient (i.e., increase its rating from less than 1 to exactly 1).
- Critical inputs and outputs for any inefficient unit which need to be given priority during the application of an improvement procedure.

DEA is a powerful technique for performance measurement (Cook & Seiford 2009). There is considerable evidence of the strengths of DEA (Ramanathan 2003).

- The main strength of DEA is its objectivity (i.e., DEA provides efficiency ratings that make the maximum possible objective use of the available data).
- Unlike statistical methods of performance analysis, DEA is non parametric in the sense that it does not require an assumption of a functional form relating inputs to outputs.
- The sources of inefficiency can be analysed and quantified for every evaluated unit.
- Large volumes of data can be handled.
- DEA can handle multiple inputs and multiple outputs, and they can be measured in very different units of measurement (Ramanathan 2003). Whereas in traditional methods of appraisals, performance indicators are limited to one measure of output input, and they cannot easily accommodate situations where multiple outputs are produced using multiple inputs (Wagner, et al. 2003). To compensate for the one dimensional nature of the indicators a large set of ratios and normative values needs to be calculated in the performance reports (Locher & Teel 1977).

Thanassoulis (1995) has given an account of a DEA application to the assessment of policing performance. The application was in the context of a major study into crime management in England and Wales, undertaken by the Audit Commission. Assessing police forces using DEA has not only more confidence in the results obtained, but also performance on specific area such as manning levels as distinct from crime clear ups gained. It identified potentially weak and strong Forces on performance, their efficient peers and the levels of clear ups that would render inefficient Forces efficient.

By utilising good data from Bell Canada on engineering design teams, Paradi, Smith, and Chatterjee (2002), were able to offer valuable advice to management, based on both the mathematical power of DEA and the managerial input. Their paper presents the performance analysis of 39 access network engineering design personnel at Bell Canada using 1994 data. The limitations of traditional performance measurement approaches used by Bell were reviewed and contrasted with the benefits offered by DEA. The primary contribution of this study, from a managerial point of view, is a demonstration of the opportunity available to the company that by repeatedly applying these DEA models it could redraw the boundaries of its service areas and increase their efficiency.

There are three basic DEA models. These frameworks are: (a) CCR (Charnes, Cooper & Rhodes

1978), (b) BCC (Banker, Charnes & Cooper 1984), and (c) CCGSS (Charnes, Cooper, Golany, Seiford & Stutz 1985). These models have different mathematical formulations, but all share the principle of envelopment (Golany & Roll 1989). In DEA both output maximisation or input minimisation are possible. The present study focuses on the output maximisation BCC model to improve the efficiency of existing inefficient employees. The BCC model has two main elements.

- Variation of outputs are not in same scale of inputs (Variable Return to Scale (VRS)).
- Increasing Return to Scale (IRS) or Decreasing Return to Scale (DRS) can be found out with this model on each DMU (i.e., employee). (Either an increase or decrease in input, which may result in output increase or decrease respectively to identify IRS or DRS.)

## Sample Applications and Example

### Sample Applications

DEA is commonly applied in the electric utilities sector. For instance a government authority can choose Data Envelope Analysis as their measuring tool to design an individualized regulatory rate for each firm based on their comparative efficiency. The input components would include man-hours, losses, capital (lines and transformers only), and goods and services. The output variables would include number of customers, energy delivered, length of lines, and degree of coastal exposure. (Berg 2010)

DEA is also regularly used to assess the efficiency of public and not-for-profit organizations, e.g. hospitals (Kuntz, Scholtes & Vera 2007; Kuntz & Vera 2007; Vera & Kuntz 2007) or police forces (Thanassoulis 1995; Sun 2002; Aristovnik et al. 2012).

#### • Example

In the DEA methodology, formally developed by Charnes, Cooper and Rhodes (1978), efficiency is defined as a ratio of weighted sum of outputs to a weighted sum of inputs, where the weights structure is calculated by means of mathematical programming and constant returns to scale (CRS) are assumed. In 1984, Banker, Charnes and Cooper developed a model with variable returns to scale (VRS).

#### Assume that we have the following data:

- Unit 1 produces 100 pieces of items per day, and the inputs are 10 dollars of materials and 2 labour-hours
- Unit 2 produces 80 pieces of items per day, and the inputs are 8 dollars of materials and 4 labour-hours
- Unit 3 produces 120 pieces of items per day, and the inputs are 12 dollars of materials and 1.5 labour-hours

To calculate the efficiency of unit 1, we define the objective function as

- maximize efficiency =  $(u_1 \times 100) / (v_1 \times 10 + v_2 \times 2)$

which is subject to all efficiency of other units (efficiency cannot be larger than 1):

- subject to the efficiency of unit 1:  $(u_1 \times 100) / (v_1 \times 10 + v_2 \times 2) \leq 1$
- subject to the efficiency of unit 2:  $(u_1 \times 80) / (v_1 \times 8 + v_2 \times 4) \leq 1$
- subject to the efficiency of unit 3:  $(u_1 \times 120) / (v_1 \times 12 + v_2 \times 1.5) \leq 1$

and non-negativity:

- all  $u$  and  $v \geq 0$ .

But since linear programming cannot handle fraction, we need to transform the formulation, such that we limit the denominator of the objective function and only allow the linear programming to maximize the numerator.

### So the new formulation would be:

- maximize Efficiency =  $u_1 * 100$
- subject to the efficiency of unit 1:  $(u_1 * 100) - (v_1 * 10 + v_2 * 2) \leq 0$
- subject to the efficiency of unit 2:  $(u_1 * 80) - (v_1 * 8 + v_2 * 4) \leq 0$
- subject to the efficiency of unit 3:  $(u_1 * 120) - (v_1 * 12 + v_2 * 1.5) \leq 0$
- subject to  $v_1 * 10 + v_2 * 2 = 1$
- all  $u$  and  $v \geq 0$ .

### Case Study

#### Employee Performance Appraisal Using Data Envelopment Analysis:

Evaluating and ranking the employees working in organisations are challenging tasks involving several factors. Each employee achieves certain performance levels in various factors and the resulting information can be overwhelming. This paper demonstrates how data envelopment analysis (DEA) can be applied as a fair evaluating and sorting tool to support the performance appraisal (PA) as well in the decision making process. DEA focuses on the best practices of efficient employees for the purpose of improving overall performance. Unlike traditional performance appraisals DEA searches for the efficient employees who will serve as peers. The DEA process identifies inefficient employees, magnitude of inefficiency and aids to eliminate inefficiencies with a relatively easy to employ framework. This study supports the ideas that rating formats need reexamination with a focus on computer based models as an alternative to traditional rating methods. Earlier adopted methods have seldom identified and quantified the individual factors for inefficiency whereas DEA could overcome these shortfalls. Based on the results of DEA the improvement of employees' performance are possible by way of providing training, talent enhancement and further qualification wherever required.

### Insights

The motor vehicle sector in India is rapidly growing. For example, the annual sales of motorcycles is expected to cross the 10 million mark by 2010, and the car statistics indicate that India will soon become one of the top 10 car manufacturing countries. Expectedly, the car production capacity will exceed the mark of two million units at the end of this fiscal year. Sustaining this sector of the Indian economy provides the imperative to focus on the strategies to preserve company growth and profitability. Consequently, a major managerial challenge is to address employee performance.

The study site is a small company located in southern India, which is involved in the manufacturing of automobile parts. This company was established six years ago and is involved in manufacturing and supplying components of carburettors (for two and four wheelers) to a manufacturing firm. Its annual turnover is INR 1.2 millions. Sixteen different components for various types of carburettors are manufactured.

### Respondents

The company employs 23 people. There are two managers under the managing director. One is in charge of manufacturing and the other has responsibility for sales/purchases. Under the control of the manager (manufacturing), there are two supervisors, one each per shift of eight hours of duty. For each shift nine employees are working who are engaged in metal machining using lathes, and drilling machines. All these 18 employees underwent a PA within a framework of DEA that provided data for this study. The managers and supervisors are not included for PA.

### Procedure

The main focus of the study is to improve the working efficiencies of the employees and to determine their training needs. Employee rankings will be used to decide the types of incentives and promotions during future expansion of the company. The factors (dataset) considered for the evaluation process



are classified into input and output factors. One of the major advantages of the DEA is the inputs and outputs can be measured and used in their own units (Sami-Mahgary & Lahdelma 1995). No universally applicable rational template is available for the selection of factors. However, in general, the inputs must reflect the resources used and the outputs must reflect the service levels of the utility and the degree to which the utility is meeting its objective (Richards 2003, Thakur 2005).

The dataset is decided upon, by having discussions and brainstorming sessions with the managers, supervisors and representatives of employees. While considering input and output factors the isotonicity relations are assumed for DEA (i.e., an increase in any input should not result in a decrease in any output). Consequently, the values of some factors may have to be inverted before they are entered into the analysis. Another group of factors is the qualitative ones. These have to be assigned numerical values in order to participate in the mathematical evaluation of efficiency. Any number of input or output factors which are relevant and have an impact on the efficiency of employees could be considered for DEA. But the number of employees in the analysis should be at least twice the number of inputs and outputs considered (Golany & Roll 1989).

### Measures

To evaluate efficiency scores of employees the following factors are used: job knowledge, customer relations, interpersonal relations, and work habits as input factors; and quality, and quantity of products produced as output factors. Among the input factors customer relations and interpersonal relations are qualitative. In a wide range of problem settings to which DEA can be applied qualitative factors are often present. Marketing's interest in consumer perception and expectation, and human resources' desire to explore and describe employees' skills are two areas that routinely involve the quantification of qualitative concepts (Dyson, Allen, Camanho, Podinovski, Sarrico & Shale 2001). Only quantitative measures are used in DEA hence, qualitative factors need to be converted into quantitative scores. Such factors may be legitimately quantifiable, but very often such quantification is superficially forced, as a modelling convenience. Typically, a qualitative factor is captured either on a Likert scale, or is represented by some quantitative surrogate such as plant downtime or percentage sick days by employees (Cook, Kress & Seiford 1996). Many authors, Roman, Wigand and Wolfgang (2003), Wong, Yang and Greatbanks (2004), Biehl, Cook and Jonston, (2006), Cook and Zho (2006) utilised a five point Likert scale to convert qualitative data into quantitative used for the evaluations of performance using DEA.

Years of experience of employees is considered to represent the job knowledge (Ross & Droge 2002) and work habits is measured with a surrogate, percentage of employees' attendance. The qualitative input factors Customer Relations and Interpersonal Relations are assessed by using a five point Likert scale with high scores reflecting better relations. In the case of Customer Relations; 1 = school final, 2 = industrial training, 3 = diploma, 4 = degree, and 5 = post graduate; and Interpersonal Relations is measured using: 1 = fair, 2 = satisfactory, 3 = good, 4 = very good, and 5 = excellent.

Unlike traditional performance appraisals, DEA searches for the efficient employees who will serve as role models. The efficiency of a machine can be determined by comparing its actual output to its engineering specifications. However, when considering human service generally, the optimum efficiency is unknown, and, therefore, cannot be determine whether an employee is absolutely efficient (Sowlati & Paradi 2004). DEA can be used to identify employees, who are relatively inefficient, measure the magnitude of the inefficiency, and aids to select the alternative paths to eliminate inefficiencies. More efficient employees, who can act as trainers to the less efficient employees, can have a stake in the employee performance improvement process. A DEA aided appraisal process has four potential benefits.

- Determines the performance levels of employees relative to others.
- Finds the shortfalls in the outputs and surpluses in inputs for employees.
- Ranks the employees in terms of their performance.



- Set targets for inefficient employees to become efficient.

### 7.2.3 Data Mining

Modern science and engineering are based on using first-principle models to describe physical, biological, and social systems. Such an approach starts with a basic scientific model, such as Newton's laws of motion or Maxwell's equations in electromagnetism, and then builds upon them various applications in mechanical engineering or electrical engineering. In this approach, experimental data are used to verify the underlying first-principle models and to estimate some of the parameters that are difficult or sometimes impossible to measure directly. However, in many domains the underlying first principles are unknown, or the systems under study are too complex to be mathematically formalized. With the growing use of computers, there is a great amount of data being generated by such systems. In the absence of first-principle models, such readily available data can be used to derive models by estimating useful relationships between a system's variables (i.e., unknown input-output dependencies). Thus there is currently a paradigm shift from classical modeling and analyses based on first principles to developing models and the corresponding analyses directly from data.

We have grown accustomed gradually to the fact that there are tremendous volumes of data filling our computers, networks, and lives. Government agencies, scientific institutions, and businesses have all dedicated enormous resources to collecting and storing data. In reality, only a small amount of these data will ever be used because, in many cases, the volumes are simply too large to manage, or the data structures themselves are too complicated to be analyzed effectively. How could this happen? The primary reason is that the original effort to create a data set is often focused on issues such as storage efficiency; it does not include a plan for how the data will eventually be used and analyzed.

The need to understand large, complex, information-rich data sets is common to virtually all fields of business, science, and engineering. In the business world, corporate and customer data are becoming recognized as a strategic asset. The ability to extract useful knowledge hidden in these data and to act on that knowledge is becoming increasingly important in today's competitive world. The entire process of applying a computer-based methodology, including new techniques, for discovering knowledge from data is called data mining.

Data mining is an iterative process within which progress is defined by discovery, through either automatic or manual methods. Data mining is most useful in an exploratory analysis scenario in which there are no predetermined notions about what will constitute an "interesting" outcome. Data mining is the search for new, valuable, and nontrivial information in large volumes of data. It is a cooperative effort of humans and computers. Best results are achieved by balancing the knowledge of human experts in describing problems and goals with the search capabilities of computers.

In practice, the two primary goals of data mining tend to be prediction and description. Prediction involves using some variables or fields in the data set to predict unknown or future values of other variables of interest. Description, on the other hand, focuses on finding patterns describing the data that can be interpreted by humans. Therefore, it is possible to put data-mining activities into one of two categories:

- (i) Predictive data mining, which produces the model of the system described by the given data set, or
- (ii) Descriptive data mining, which produces new, nontrivial information based on the available data set.

On the predictive end of the spectrum, the goal of data mining is to produce a model, expressed as an executable code, which can be used to perform classification, prediction, estimation, or other similar tasks. On the other, descriptive, end of the spectrum, the goal is to gain an understanding of the analyzed system by uncovering patterns and relationships in large data sets. The relative importance

of prediction and description for particular data-mining applications can vary considerably. The goals of prediction and description are achieved by using data-mining techniques, explained later in this book, for the following primary data-mining tasks:

- (i) **Classification** - discovery of a predictive learning function that classifies a data item into one of several predefined classes.
- (ii) **Regression** - discovery of a predictive learning function, which maps a data item to a real-value prediction variable.
- (iii) **Clustering** - a common descriptive task in which one seeks to identify a finite set of categories or clusters to describe the data.
- (iv) **Summarization** - an additional descriptive task that involves methods for finding a compact description for a set (or subset) of data.
- (v) **Dependency Modeling** - finding a local model that describes significant dependencies between variables or between the values of a feature in a data set or in a part of a data set.
- (vi) **Change and Deviation Detection** - discovering the most significant changes in the data set

The success of a data-mining engagement depends largely on the amount of energy, knowledge, and creativity that the designer puts into it. In essence, data mining is like solving a puzzle. The individual pieces of the puzzle are not complex structures in and of themselves. Taken as a collective whole, however, they can constitute very elaborate systems. As you try to unravel these systems, you will probably get frustrated, start forcing parts together, and generally become annoyed at the entire process; but once you know how to work with the pieces, you realize that it was not really that hard in the first place. The same analogy can be applied to data mining. In the beginning, the designers of the data-mining process probably do not know much about the data sources; if they did, they would most likely not be interested in performing data mining. Individually, the data seem simple, complete, and explainable. But collectively, they take on a whole new appearance that is intimidating and difficult to comprehend, like the puzzle. Therefore, being an analyst and designer in a data-mining process requires, besides thorough professional knowledge, creative thinking and a willingness to see problems in a different light.

Data mining is one of the fastest growing fields in the computer industry. Once a small interest area within computer science and statistics, it has quickly expanded into a field of its own. One of the greatest strengths of data mining is reflected in its wide range of methodologies and techniques that can be applied to a host of problem sets. Since data mining is a natural activity to be performed on large data sets, one of the largest target markets is the entire data warehousing, data-mart, and decision-support community, encompassing professionals from such industries as retail, manufacturing, telecommunications, healthcare, insurance, and transportation. In the business community, data mining can be used to discover new purchasing trends, plan investment strategies, and detect unauthorized expenditures in the accounting system. It can improve marketing campaigns and the outcomes can be used to provide customers with more focused support and attention. Data-mining techniques can be applied to problems of business process reengineering, in which the goal is to understand interactions and relationships among business practices and organizations.

Many law enforcement and special investigative units, whose mission is to identify fraudulent activities and discover crime trends, have also used data mining successfully. For example, these methodologies can aid analysts in the identification of critical behavior patterns in the communication interactions of narcotics organizations, the monetary transactions of money laundering and insider trading operations, the movements of serial killers, and the targeting of smugglers at border crossings. Data-mining techniques have also been employed by people in the intelligence community who maintain many large data sources as a part of the activities relating to matters of national security. Appendix B of the book gives a brief overview of typical commercial applications of data-mining technology today.

## Data-Mining Roots

Looking at how different authors describe data mining, it is clear that we are far from a universal agreement on the definition of data mining or even what constitutes data mining. Is data mining a form of statistics enriched with learning theory or is it a revolutionary new concept? In our view, most data-mining problems and corresponding solutions have roots in classical data analysis. Data mining has its origins in various disciplines, of which the two most important are statistics and machine learning. Statistics has its roots in mathematics, and therefore, there has been an emphasis on mathematical rigor, a desire to establish that something is sensible on theoretical grounds before testing it in practice. In contrast, the machine-learning community has its origins very much in computer practice. This has led to a practical orientation, a willingness to test something out to see how well it performs, without waiting for a formal proof of effectiveness.

If the place given to mathematics and formalizations is one of the major differences between statistical and machine-learning approaches to data mining, another is in the relative emphasis they give to models and algorithms. Modern statistics is almost entirely driven by the notion of a model. This is a postulated structure, or an approximation to a structure, which could have led to the data. In place of the statistical emphasis on models, machine learning tends to emphasize algorithms. This is hardly surprising; the very word "learning" contains the notion of a process, an implicit algorithm.

Basic modeling principles in data mining also have roots in control theory, which is primarily applied to engineering systems and industrial processes. The problem of determining a mathematical model for an unknown system (also referred to as the target system) by observing its input-output data pairs is generally referred to as system identification. The purposes of system identification are multiple and, from a standpoint of data mining, the most important are to predict a system's behavior and to explain the interaction and relationships between the variables of a system.

### System identification generally involves two top-down steps:

- (i) Structure identification - In this step, we need to apply a priori knowledge about the target system to determine a class of models within which the search for the most suitable model is to be conducted. Usually this class of models is denoted by a parametrized function  $y = f(u, t)$ , where  $y$  is the model's output,  $u$  is an input vector, and  $t$  is a parameter vector. The determination of the function  $f$  is problem-dependent, and the function is based on the designer's experience, intuition, and the laws of nature governing the target system.
- (ii) Parameter identification - In the second step, when the structure of the model is known, all we need to do is apply optimization techniques to determine parameter vector  $t$  such that the resulting model  $y^* = f(u, t^*)$  can describe the system appropriately.

In general, system identification is not a one-pass process: both structure and parameter identification need to be done repeatedly until a satisfactory model is found. This iterative process is represented graphically in the following figure. Typical steps in every iteration are as follows:

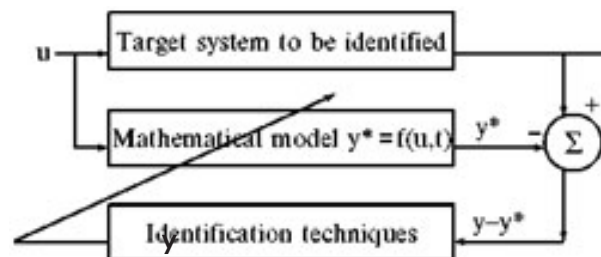

**Figure Block Diagram for Parameter Identification**

- (i) Specify and parametrize a class of formalized (mathematical) models,  $y^* = f(u, t)$ , representing the system to be identified.

- (ii) Perform parameter identification to choose the parameters that best fit the available data set (the difference  $y - y^*$  is minimal).
- (iii) Conduct validation tests to see if the model identified responds correctly to an unseen data set (often referred as test, validating, or checking data set).
- (iv) Terminate the process once the results of the validation test are satisfactory.

If we do not have any a priori knowledge about the target system, then structure identification becomes difficult, and we have to select the structure by trial and error. While we know a great deal about the structures of most engineering systems and industrial processes, in a vast majority of target systems where we apply data-mining techniques, these structures are totally unknown, or they are so complex that it is impossible to obtain an adequate mathematical model. Therefore, new techniques were developed for parameter identification and they are today a part of the spectra of data-mining techniques.

Finally, we can distinguish between how the terms “model” and “pattern” are interpreted in data mining. A model is a “large scale” structure, perhaps summarizing relationships over many (sometimes all) cases, whereas a pattern is a local structure, satisfied by few cases or in a small region of a data space. It is also worth noting here that the word “pattern”, as it is used in pattern recognition, has a rather different meaning for data mining. In pattern recognition it refers to the vector of measurements characterizing a particular object, which is a point in a multidimensional data space. In data mining, a pattern is simply a local model. In this book we refer to n-dimensional vectors of data as samples.

### **Data-Mining Process**

Without trying to cover all possible approaches and all different views about data mining as a discipline, let us start with one possible, sufficiently broad definition of data mining:

Data Mining is a process of discovering various models, summaries, and derived values from a given collection of data.

The word “process” is very important here. Even in some professional environments there is a belief that data mining simply consists of picking and applying a computer-based tool to match the presented problem and automatically obtaining a solution. This is a misconception based on an artificial idealization of the world. There are several reasons why this is incorrect. One reason is that data mining is not simply a collection of isolated tools, each completely different from the other, and waiting to be matched to the problem. A second reason lies in the notion of matching a problem to a technique. Only very rarely is a research question stated sufficiently precisely that a single and simple application of the method will suffice. In fact, what happens in practice is that data mining becomes an iterative process. One studies the data, examines it using some analytic technique, decides to look at it another way, perhaps modifying it, and then goes back to the beginning and applies another data-analysis tool, reaching either better or different results. This can go round and round many times; each technique is used to probe slightly different aspects of data—to ask a slightly different question of the data. What is essentially being described here is a voyage of discovery that makes modern data mining exciting. Still, data mining is not a random application of statistical, machine learning, and other methods and tools. It is not a random walk through the space of analytic techniques but a carefully planned and considered process of deciding what will be most useful, promising, and revealing.

It is important to realize that the problem of discovering or estimating dependencies from data or discovering totally new data is only one part of the general experimental procedure used by scientists, engineers, and others who apply standard steps to draw conclusions from the data. The general experimental procedure adapted to data-mining problems involves the following steps:

#### **1. State the problem and formulate the hypothesis**

Most data-based modeling studies are performed in a particular application domain. Hence, domain-specific knowledge and experience are usually necessary in order to come up with a meaningful

problem statement. Unfortunately, many application studies tend to focus on the data-mining technique at the expense of a clear problem statement. In this step, a modeler usually specifies a set of variables for the unknown dependency and, if possible, a general form of this dependency as an initial hypothesis. There may be several hypotheses formulated for a single problem at this stage. The first step requires the combined expertise of an application domain and a data-mining model. In practice, it usually means a close interaction between the data-mining expert and the application expert. In successful data-mining applications, this cooperation does not stop in the initial phase; it continues during the entire data-mining process.

## 2. Collect the data

This step is concerned with how the data are generated and collected. In general, there are two distinct possibilities. The first is when the data-generation process is under the control of an expert (modeler): this approach is known as a designed experiment. The second possibility is when the expert cannot influence the data-generation process: this is known as the observational approach. An observational setting, namely, random data generation, is assumed in most data-mining applications. Typically, the sampling distribution is completely unknown after data are collected, or it is partially and implicitly given in the data-collection procedure. It is very important, however, to understand how data collection affects its theoretical distribution, since such a priori knowledge can be very useful for modeling and, later, for the final interpretation of results. Also, it is important to make sure that the data used for estimating a model and the data used later for testing and applying a model come from the same, unknown, sampling distribution. If this is not the case, the estimated model cannot be successfully used in a final application of the results.

## 3. Preprocessing the data

In the observational setting, data are usually “collected” from the existing databases, data warehouses, and data marts. Data preprocessing usually includes at least two common tasks:

- (i) **Outlier detection (and removal)** - Outliers are unusual data values that are not consistent with most observations. Commonly, outliers result from measurement errors, coding and recording errors, and, sometimes, are natural, abnormal values. Such non representative samples can seriously affect the model produced later. There are two strategies for dealing with outliers:
  - a) Detect and eventually remove outliers as a part of the preprocessing phase, or
  - b) Develop robust modeling methods that are insensitive to outliers.
- (ii) **Scaling, encoding, and selecting features** - Data preprocessing includes several steps such as variable scaling and different types of encoding. For example, one feature with the range [0, 1] and the other with the range [-100, 1000] will not have the same weights in the applied technique; they will also influence the final data-mining results differently. Therefore, it is recommended to scale them and bring both features to the same weight for further analysis. Also, application-specific encoding methods usually achieve dimensionality reduction by providing a smaller number of informative features for subsequent data modeling.

These two classes of preprocessing tasks are only illustrative examples of a large spectrum of preprocessing activities in a data-mining process.

Data-preprocessing steps should not be considered completely independent from other data-mining phases. In every iteration of the data-mining process, all activities, together, could define new and improved data sets for subsequent iterations. Generally, a good preprocessing method provides an optimal representation for a data-mining technique by incorporating a priori knowledge in the form of application-specific scaling and encoding.

## 4. Estimate the model

The selection and implementation of the appropriate data-mining technique is the main task in this phase. This process is not straightforward; usually, in practice, the implementation is based on several models, and selecting the best one is an additional task.

## 5. Interpret the model and draw conclusions

In most cases, data-mining models should help in decision making. Hence, such models need to be interpretable in order to be useful because humans are not likely to base their decisions on complex “black-box” models. Note that the goals of accuracy of the model and accuracy of its interpretation are somewhat contradictory. Usually, simple models are more interpretable, but they are also less accurate. Modern data-mining methods are expected to yield highly accurate results using high-dimensional models. The problem of interpreting these models, also very important, is considered a separate task, with specific techniques to validate the results. A user does not want hundreds of pages of numeric results. He does not understand them; he cannot summarize, interpret, and use them for successful decision-making.

All phases, separately, and the entire data-mining process, as a whole, are highly iterative, as has been shown in the following figure. A good understanding of the whole process is important for any successful application. No matter how powerful the data-mining method used in step 4 is, the resulting model will not be valid if the data are not collected and preprocessed correctly, or if the problem formulation is not meaningful.

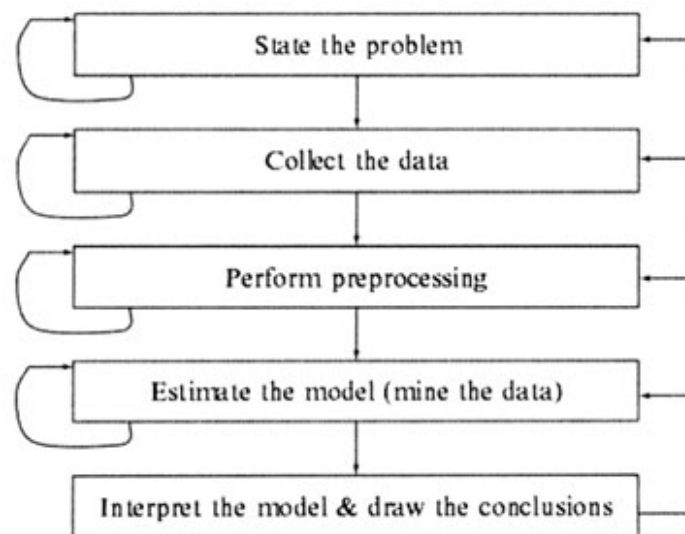

Fig : The Data-mining Process

### Large Data Sets

As we enter into the age of digital information, the problem of data overload looms ominously ahead. Our ability to analyze and understand massive data sets, as we call large data, is far behind our ability to gather and store the data. Large databases of digital information are ubiquitous. Data from the neighborhood store's checkout register, your bank's credit card authorization device, records in your doctor's office, patterns in your telephone calls, and many more applications generate streams of digital records archived in huge business databases. Scientists are at the higher end of today's data-collection machinery, using data from different sources—from remote-sensing platforms to microscope probing of cell details. Scientific instruments can easily generate terabytes of data in a short period of time and store them in the computer. The information age, with the expansion of the Internet, has caused an exponential growth in information sources and also in information-storage units. An illustrative example is given in the following figure, where we can see a dramatic increase of Internet hosts in just the last three years, where these numbers are directly proportional to the amount of data stored on the Internet.

There is a rapidly widening gap between data-collection and data-organization capabilities and the ability to analyze the data. Current hardware and database technology allows efficient, inexpensive,

and reliable data storage and access. However, whether the context is business, medicine, science, or government, the data sets themselves, in their raw form, are of little direct value. What is of value is the knowledge that can be inferred from the data and put to use. For example, the marketing database of a consumer goods company may yield knowledge of the correlation between sales of certain items and certain demographic groupings. This knowledge can be used to introduce new, targeted marketing campaigns with a predictable financial return, as opposed to unfocused campaigns.

The root of the problem is that the data size and dimensionality are too large for manual analysis and interpretation, or even for some semiautomatic computer-based analyses. A scientist or a business manager can work effectively with a few hundred or thousand records. Effectively mining millions of data points, each described with tens or hundreds of characteristics, is another matter. Imagine the analysis of terabytes of sky-image data with thousands of photographic high-resolution images (23,040 x 23,040 pixels per image), or human genome databases with billions of components. In theory, "big data" can lead to much stronger conclusions, but in

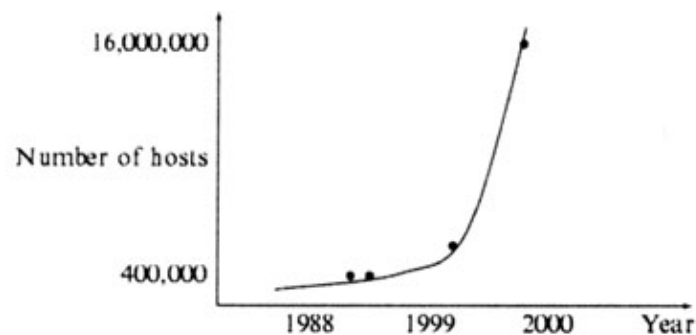

**Fig : Growth of Internet Hosts**

practice many difficulties arise. The business community is well aware of today's information overload, and one analysis shows that

- (i) 61% of managers believe that information overload is present in their own workplace,
- (ii) 80% believe the situation will get worse,
- (iii) over 50% of the managers ignore data in current decision-making processes because of the information overload,
- (iv) 84% of managers store this information for the future; it is not used for current analysis,
- (v) 60% believe that the cost of gathering information outweighs its value.

What are the solutions? Work harder. Yes, but how long can you keep up, because the limits are very close. Employ an assistant. Maybe, if you can afford it. Ignore the data. But then you are not competitive in the market. The only real solution will be to replace classical data analysis and interpretation methodologies (both manual and computer-based) with a new data-mining technology.

In theory, most data-mining methods should be happy with large data sets. Large data sets have the potential to yield more valuable information. If data mining is a search through a space of possibilities, then large data sets suggest many more possibilities to enumerate and evaluate. The potential for increased enumeration and search is counterbalanced by practical limitations. Besides the computational complexity of the data-mining algorithms that work with large data sets, a more exhaustive search may also increase the risk of finding some low-probability solutions that evaluate well for the given data set, but may not meet future expectations.

In today's multimedia-based environment that has a huge Internet infrastructure, different types of data are generated and digitally stored. To prepare adequate data-mining methods, we have to analyze the basic types and characteristics of datasets. The first step in this analysis is systematization of



data with respect to their computer representation and use. Data that is usually the source for a data-mining process can be classified into structured data, semi-structured data, and unstructured data.

Most business databases contain structured data consisting of well-defined fields with numeric or alphanumeric values, while scientific databases may contain all three classes. Examples of semi-structured data are electronic images of business documents, medical reports, executive summaries, and repair manuals. The majority of web documents also fall in this category. An example of unstructured data is a video recorded by a surveillance camera in a department store. Such visual and, in general, multimedia recordings of events or processes of interest are currently gaining widespread popularity because of reduced hardware costs. This form of data generally requires extensive processing to extract and structure the information contained in it.

Structured data is often referred to as traditional data, while the semi-structured and unstructured data are lumped together as nontraditional data (also called multimedia data). Most of the current data-mining methods and commercial tools are applied to traditional data. However, the development of data-mining tools for nontraditional data, as well as interfaces for its transformation into structured formats, is progressing at a rapid rate.

The standard model of structured data for data mining is a collection of cases. Potential measurements called features are specified, and these features are uniformly measured over many cases. Usually the representation of structured data for data-mining problems is in a tabular form, or in the form of a single relation (term used in relational databases), where columns are features of objects stored in a table and rows are values of these features for specific entities. A simplified graphical representation of a data set and its characteristics is given in Figure 1.4. In the data-mining literature, we usually use the terms samples or cases for rows. Many different types of features (attributes or variables) — i.e., fields—in structured data records are common in data mining. Not all of the data-mining methods are equally good at dealing with different types of features.

There are several ways of characterizing features. One way of looking at a feature—or in a formalization process, the more often-used term; variable—is to see whether it is an independent variable or a dependent variable; i.e, whether or not it is a variable whose values depend upon values of other variables represented in a data set. This is a model-based approach to classifying variables. All dependent variables are accepted as outputs from the system for which we are establishing a model, and independent variables are inputs to the system, as represented in the following figure.

There are some additional variables that influence system behavior, but the corresponding values are not available in a data set during a modeling process. The reasons are different: from high complexity and the cost of measurements for these features to a modeler's not understanding the importance of some factors and their influences on the model. These are usually called unobserved variables, and they are the main cause of ambiguities and estimations in a model.

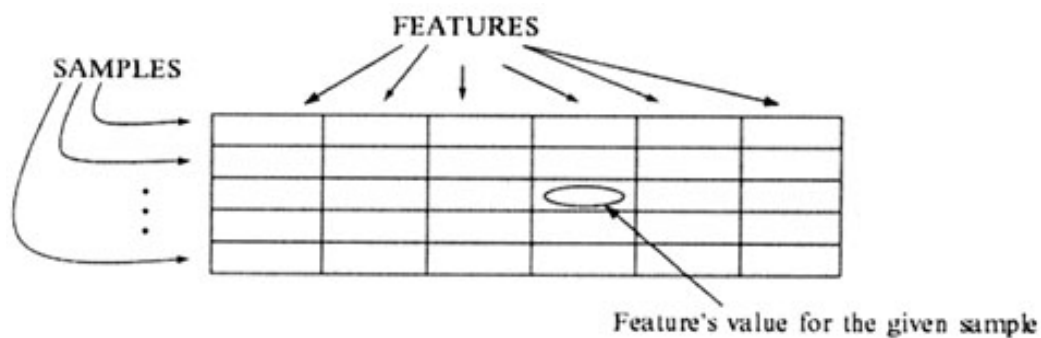

**Fig : Tabular Representation of a Data Set**

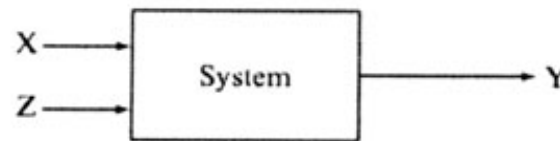

**Fig : A real system, besides input (independent) variables X and (dependent) outputs Y, often has unabsorbed inputs Z.**

Today's computers and corresponding software tools support the processing of data sets with millions of samples and hundreds of features. Large data sets, including those with mixed data types, are a typical initial environment for application of data-mining techniques. When a large amount of data is stored in a computer, one cannot rush into data-mining techniques, because the important problem of data quality has first to be resolved. Also, it is obvious that a manual quality analysis is not possible at that stage. Therefore, it is necessary to prepare a data-quality analysis in the earliest phases of the data-mining process; usually it is a task to be undertaken in the data-preprocessing phase. The quality of data has a profound effect on the image of the system and determines the corresponding model that is implicitly described; it could also limit the ability of end users to make informed decisions. Using the available data-mining techniques, it will be difficult to undertake major qualitative changes in an organization if the data is of a poor quality; similarly, to make new sound discoveries from poor quality scientific data will be almost impossible. There are a number of indicators of data quality:

- (i) The data should be accurate. The analyst has to check that the name is spelled correctly, the code is in a given range, the value is complete, etc.
- (ii) The data should be stored according to data type. The analyst must ensure that the numeric value is not presented in character form, that integers are not in the form of real numbers, etc.
- (iii) The data should have integrity. Updates should not be lost because of conflicts among different users; robust backup and recovery procedures should be implemented if they are not already part of the Data Base Management System (DBMS).
- (iv) The data should be consistent. The form and the content should be the same after integration of large data sets from different sources.
- (v) The data should not be redundant. In practice, redundant data should be minimized and reasoned duplication should be controlled. Duplicated records should be eliminated.
- (vi) The data should be timely. The time component of data should be recognized explicitly from the data or implicitly from the manner of its organization.
- (vii) The data should be well understood. Naming standards are a necessary but not the only condition for data to be well understood. The user should know that the data corresponds to an established domain.
- (viii) The data set should be complete. Missing data, which occurs in reality, should be minimized. Missing data could reduce the quality of a global model. On the other hand, some data-mining techniques are robust enough to support analyses of data sets with missing values.

### **Data Warehouses**

Although the existence of a data warehouse is not a prerequisite for data mining, in practice, the task of data mining, especially for some large companies, is made a lot easier by having access to a data warehouse. A primary goal of a data warehouse is to increase the "intelligence" of a decision process and the knowledge of the people involved in this process. For example, the ability of product marketing executives to look at multiple dimensions of a product's sales performance—by region, by type of sales, by customer demographics—may enable better promotional efforts, increased production, or new decisions in product inventory and distribution. It should be noted that average companies work with

averages. The superstars differentiate themselves by paying attention to the details. They may need to slice and dice the data in different ways to obtain a deeper understanding of their organization and to make possible improvements. To undertake these processes, users have to know what data exists, where it is located, and how to access it.

A data warehouse means different things to different people. Some definitions are limited to data; others refer to people, processes, software, tools, and data. One of the global definitions is that the data warehouse is a collection of integrated, subject-oriented databases designed to support the decision-support functions (DSF), where each unit of data is relevant to some moment in time.

Based on this definition, a data warehouse can be viewed as an organization's repository of data, set up to support strategic decision-making. The function of the data warehouse is to store the historical data of an organization in an integrated manner that reflects the various facets of the organization and business. The data in a warehouse are never updated but used only to respond to queries from end users who are generally decision-makers. Typically, data warehouses are huge, storing billions of records. In many instances, an organization may have several local or departmental data warehouses often called data marts. A data mart is a data warehouse that has been designed to meet the needs of a specific group of users. It may be large or small, depending on the subject area.

At this early time in the evolution of data warehouses, it is not surprising to find many projects floundering because of the basic misunderstanding of what a data warehouse is. What does surprise is the size and scale of these projects. Many companies err by not defining exactly what a data warehouse is, the business problems it will solve, and the uses to which it will be put. Two aspects of a data warehouse are most important for a better understanding of its design process: the first is the specific types (classification) of data stored in a data warehouse, and the second is the set of transformations used to prepare the data in the final form such that it is useful for decision making. A data warehouse includes the following categories of data, where the classification is accommodated to the time-dependent data sources:

- (i) Old detail data
- (ii) Current (new) detail data
- (iii) Lightly summarized data
- (iv) Highly summarized data
- (v) Metadata (the data directory or guide).

To prepare these five types of elementary or derived data in a data warehouse, the fundamental types of data transformation are standardized. There are four main types of transformations, and each has its own characteristics:

- (i) Simple transformations** - These transformations are the building blocks of all other more complex transformations. This category includes manipulation of data that is focused on one field at a time, without taking into account its values in related fields. Examples include changing the data type of a field or replacing an encoded field value with a decoded value.
- (ii) Cleansing and scrubbing** - These transformations ensure consistent formatting and usage of a field, or of related groups of fields. This can include a proper formatting of address information, for example. This class of transformations also includes checks for valid values in a particular field, usually checking the range or choosing from an enumerated list.
- (iii) Integration** - This is a process of taking operational data from one or more sources and mapping it, field by field, onto a new data structure in the data warehouse. The common identifier problem is one of the most difficult integration issues in building a data warehouse. Essentially, this situation occurs when there are multiple system sources for the same entities and there is no clear way to identify those entities as the same. This is a challenging problem, and in many cases it cannot be solved in an automated fashion. It frequently requires sophisticated algorithms to pair up probable



matches. Another complex data-integration scenario occurs when there are multiple sources for the same data element. In reality, it is common that some of these values are contradictory, and resolving a conflict is not a straightforward process. Just as difficult as having conflicting values is having no value for a data element in a warehouse. All these problems and corresponding automatic or semiautomatic solutions are always domain-dependent.

- (iv) Aggregation and summarization** - These are methods of condensing instances of data found in the operational environment into fewer instances in the warehouse environment. Although the terms aggregation and summarization are often used interchangeably in the literature, we believe that they do have slightly different meanings in the data-warehouse context. Summarization is a simple addition of values along one or more data dimensions; e.g., adding up daily sales to produce monthly sales. Aggregation refers to the addition of different business elements into a common total; it is highly domain-dependent. For example, aggregation is adding daily product sales and monthly consulting sales to get the combined, monthly total.

These transformations are the main reason why we prefer a warehouse as a source of data for a data-mining process. If the data warehouse is available, the preprocessing phase in data mining is significantly reduced, sometimes even eliminated. Do not forget that this preparation of data is the most time-consuming phase.

Although the implementation of a data warehouse is a complex task, described in many texts in great detail, in this text we are giving only the basic characteristics. A three-stage data-warehousing development process is summarized through the following basic steps:

- (i) Modeling** - In simple terms, to take the time to understand business processes, the information requirements of these processes, and the decisions that are currently made within processes.
- (ii) Building** - To establish requirements for tools that suit the types of decision support necessary for the targeted business process; to create a data model that helps further define information requirements; to decompose problems into data specifications and the actual data store, which will, in its final form, represent either a data mart or a more comprehensive data warehouse.
- (iii) Deploying** - To implement, relatively early in the overall process, the nature of the data to be warehoused and the various business intelligence tools to be employed; to begin by training users. The deploy stage explicitly contains a time during which users explore both the repository (to understand data that are and should be available) and early versions of the actual data warehouse. This can lead to an evolution of the data warehouse, which involves adding more data, extending historical periods, or returning to the build stage to expand the scope of the data warehouse through a data model.

Data mining represents one of the major applications for data warehousing, since the sole function of a data warehouse is to provide information to end users for decision support. Unlike other query tools and application systems, the data-mining process provides an end-user with the capacity to extract hidden, nontrivial information. Such information, although more difficult to extract, can provide bigger business and scientific advantages and yield higher returns on "data warehousing and data mining" investments.

How is data mining different from other typical applications of a data warehouse, such as structured query languages (SQL) and on-line analytical processing tools (OLAP), which are also applied to data warehouses? SQL is a standard relational database language that is good for queries that impose some kind of constraints on data in the database in order to extract an answer. In contrast, data-mining methods are good for queries that are exploratory in nature, trying to extract hidden, not so obvious information. SQL is useful when we know exactly what we are looking for and we can describe it formally. We will use data-mining methods when we know only vaguely what we are looking for. Therefore, these two classes of data-warehousing applications are complementary.

OLAP tools and methods have become very popular in recent years as they let users analyze data in a

warehouse by providing multiple views of the data, supported by advanced graphical representations. In these views, different dimensions of data correspond to different business characteristics. OLAP tools make it very easy to look at dimensional data from any angle or to slice-and-dice it. Although OLAP tools, like data-mining tools, provide answers that are derived from data, the similarity between them ends here. The derivation of answers from data in OLAP is analogous to calculations in a spreadsheet; because they use simple and given-in-advance calculations, OLAP tools do not learn from data, nor do they create new knowledge. They are usually special-purpose visualization tools that can help end-users draw their own conclusions and decisions, based on graphically condensed data. OLAP tools are very useful for the data-mining process; they can be a part of it but they are not a substitute.

What is meant by the phrase "Data Quality"? Any good definition of data quality must include a discussion of the data's "fitness for purpose." Quality data is as complete, valid, accurate, consistent and timely as is required by the specific purpose of the data. Data is not collected and warehoused at great expense by organizations of all sizes just because they have excess disk space; rather, data is collected for many reasons. Data is collected for use by decision makers as a framework for their thought processes and for use by auditors to insure regulatory compliance, among other reasons. Simply put, data is intended to be used. And the fitness of the data for its intended use is what we refer to as data quality. The consequences of poor data quality depend on the specific use of the data but these consequences can include, for example, lost revenue, dissatisfied customers or, in extreme cases, fines or even imprisonment due to regulatory violations.

#### **7.2.4 Data Quality**

Data quality is a perception or an assessment of data's fitness to serve its purpose in a given context.

Aspects of data quality include:

- Accuracy
- Completeness
- Update status
- Relevance
- Consistency across data sources
- Reliability
- Appropriate presentation
- Accessibility

Within an organization, acceptable data quality is crucial to operational and transactional processes and to the reliability of business analytics (BA) / business intelligence (BI) reporting. Data quality is affected by the way data is entered, stored and managed. Data quality assurance (DQA) is the process of verifying the reliability and effectiveness of data.

Maintaining data quality requires going through the data periodically and scrubbing it. Typically this involves updating it, standardizing it, and de-duplicating records to create a single view of the data, even if it is stored in multiple disparate systems. There are many vendor applications on the market to make this job easier.



**Fig. Data Quality Dimensions**

### **Data Quality Dimensions**

We can assess data quality using five core dimensions: completeness, validity, accuracy, consistency and timeliness.

#### **Completeness**

Data quality completeness is the degree to which required data elements are populated. But whether a data element is “required” depends on the use of the data. For instance, to send an email newsletter to your customers, you need at least the customer’s name and a valid email address, but their phone number is not necessary. If you only have email addresses for 45% of your customers, an email newsletter may not be the most effective method to reach them. A typical database query to obtain your email address list provides you with no indication as to the completeness of that data element. Without at some point assessing the completeness of the email data element in your entire customer database, you may not realize that you are communicating to only a small subset of your intended customer base.

#### **Validity**

Data quality validity is the degree to which data elements satisfy their semantic constraints. Semantic constraints may be syntactic, format or valid values constraints on a data element. For example, an email address without the “at” (“@”) symbol doesn’t meet the syntax constraint for a valid email address. A date field, to use another example, may be required to be in the MM/DD/YYYY format, such as 01/23/1965 to be considered valid. Finally, a gender data element may be constrained to a valid value list: {Male, Female, Unknown}.

Continuing the newsletter example; if you simply email the newsletter to all of the values found in the email data element in your customer database, there are bound to be many newsletters that are not deliverable due to their invalid email addresses. A variety of problems contribute to invalid data—from the lack of semantic constraints in the data entry system, to legacy data migration problems, to simple human error. Data validity doesn’t mean that the value is correct (for example, that the customer’s email address listed is current and correctly spelled); it only means that it’s properly formatted. If the newsletter is intended only for your female customers, and you correctly query the database for all “Female” gender customers, you may miss other female customers whose gender has been invalidly stored as “F” or “Woman.” If the newsletter is targeting customers born in a specific month (“Happy Birthday” specials), and there are invalidly formatted birth dates in your data such as 23/01/1965 (DD/MM/YYYY instead of MM/DD/YYYY), those customers would also be missed by your mailing.

### **Accuracy**

Data quality accuracy is the degree to which data elements contain correct values. Does the valid gender data element in your customer data reflect the customer's true gender? If the customer's gender is inaccurate, you may be communicating ineffectively with them or even offending them, perhaps sending your female-oriented newsletter to men inaccurately indicated as female in your data.

One common data quality accuracy problem comes from duplicate data records. Duplicate records can arise for a variety of reasons, most commonly through combining records from multiple legacy systems into one new central data warehouse. This is also a common problem that can occur when two companies merge operations. Both companies may have served an overlapping set of customers prior to the merger. Are M. Smith and Mark Smyth at 100 North Main Street the same customer? Possibly, but depending how the data integration was handled, the same customer might now be listed twice in your database.

### **Consistency**

Data quality consistency is the degree of variability or contradiction of data element values. Inconsistent data can be an artifact of data capture system problems or policy/procedure adherence issues. For instance, your company policy might be that all travel reservations should be processed through a single travel agency so that proper supplier discounts are applied. Your accounting data should show consistent travel expenses paid via the approved travel agency. Any inconsistency in the values of the accounting data showing expenses paid to another travel agency would indicate a potential policy violation that could be costing your company the value of the negotiated travel discounts.

Contradictory values in your data could also point to system or procedural issues. Suppose the correct description of part number 1234B in your parts database is "spare tire." Through your data quality monitoring program, you discover that your orders system has order entries for part number 1234B with the description, "lug nut." Investigating the source of that data consistency contradiction could lead you to uncover a programming issue in your new order entry system.

### **Timeliness**

Data quality timeliness is the degree to which data elements are current. Any type of accurate forecasting is only going to be as good as the timeliness of the data on which the forecast is based. Forecasting sales of mailboxes is dependent upon data about new home construction. For example, if you were trying to plan how many mailboxes to manufacture next week and your new home construction data was two months old, your forecast would be much less accurate than if you had more timely construction data.

In addition, a company attempting to implement a just-in-time inventory system would run into trouble if its sales staff only entered customer orders into the order entry system on a weekly basis. If the company normally sold 500 widgets a week and a new order for 7,000 widgets came in on a Monday, but the order data isn't available until Friday, the components required to manufacture those 7,000 widgets would not be available when needed.

### **Summary**

The measurement and reporting of the above core data quality dimensions should be the goals of any data quality monitoring program.

### **Five Fundamental Data Quality Practices**

Data quality management incorporates a "virtuous cycle" in which continuous analysis, observation, and improvement lead to overall improvement in the quality of organizational information across the board. The results of each iteration can improve the value of an organization's data asset and the ways that data asset supports the achievement of business objectives.



This cycle turns on the execution of five fundamental data quality management practices, which are ultimately implemented using a combination of core data services. Those practices are:

- Data quality assessment
- Data quality measurement
- Integrating data quality into the application infrastructure
- Operational data quality improvement
- Data quality incident management

By enabling repeatable processes for managing the observance of data quality expectations, these practices provide a solid foundation for enterprise data quality management. This paper describes these practices and then looks at the core data services upon which these practices rely. Each section will provide an overview of the practice and review processes that are used to achieve the desired practice's objectives. By combining good data management practices with the right technology platform, an organization can fully incorporate data quality into the enterprise architecture.

Data quality management practices can improve the value of an organization's data asset and the ways it supports the achievement of business objectives.

### **The Virtuous Cycle of Data Quality**

Data quality management incorporates a "virtuous cycle" in which continuous analysis, observation, and improvement lead to overall improvement in the quality of organizational information across the board (see below). The objective of this cycle is to transition from being an organization in which the data stewards react to acute data failures into an organization that proactively controls and limits the introduction of data flaws into the environment.

In turn, this virtuous cycle incorporates five fundamental data quality management practices, which are ultimately implemented using a combination of core data services. Those practices are:

- (i) Data quality assessment, as a way for the practitioner to understand the scope of how poor data quality affects the ways that the business processes are intended to run, and to develop a business case for data quality management;
- (ii) Data quality measurement, in which the data quality analysts synthesize the results assessment and concentrate on the data elements that are deemed critical based on the selected business users' needs. This leads to the definition of performance metrics that feed management reporting via data quality scorecards;
- (iii) Integrating data quality into the application infrastructure, by way of integrating data requirements analysis across the organization and by engineering data quality into the system development life cycle;
- (iv) Operational data quality improvement, where data stewardship procedures are used to manage identified data quality rules, conformance to acceptability thresholds, supported by
- (v) Data quality incident management, which allows the data quality analysts to review the degree to which the data does or does not meet the levels of acceptability, report, log, and track issues, and document the processes for remediation and improvement.





Together, these practices establish the foundation of the data quality management program, since they enable a repeatable process for incrementally accumulating metrics for data quality that will contribute to populating a data quality scorecard, a data quality dashboard, as well as driving proactive data quality management. In turn, trained staff must employ core data services to make these practices operational.

### Data Quality Assessment

Smart organizations want to maximize their investment in data quality management, and this means understanding how poor data quality negatively impacts the achievement of business objectives. By quantifying that value gap, the data quality practitioner can determine the cost-effectiveness, feasibility, and speed of any proposed data quality improvement. Understanding the impacts of data flaws within the context of the business helps provides a yardstick to measure and prioritize emergent data issues.

As an example, there may be some suspicion of increased mailing and shipping costs due to inaccurate or invalid addresses. This suspicion may be introduced by a perception of a large number of undelivered shipped items returned. However, invalid or incorrect addresses not only incurs direct costs associated with returned items; analytical applications used to profile customer purchase patterns by region are skewed, which can impact the effective execution of marketing campaigns and regional sales promotions. The data quality assessment process can be used to quantify those costs and impacts and determine what percentage of those costs is directly attributed to addresses that can be corrected.

This practice incorporates processes for identifying, assessing, quantifying, and prioritizing data quality issues:

- **Business impact analysis** – this process is intended to guide the analysts by noting any potential data-related issues that increase costs, reduce revenues, impact margins, or introduce inefficiencies or delays in business activities. In essence, the objective is to identify any negative business impacts that can be attributed to data of unacceptable quality. Identifying the location and magnitude of critical pain points in the various business processes helps to scope the business requirements for information for the assessment, narrow the list of data sets that will be examined, and guide the identification of data quality requirements.
- **Data quality assessment using data profiling** – this process performs a bottom-up review of the actual data as a way to isolate apparent anomalies that may be real data flaws. Using data profiling and other statistical and analysis techniques, the analysts can identify these apparent anomalies, which can be subjected to further scrutiny when reviewed with business data consumers.



- **Data quality assessment anomaly review** – during this process, the data quality analysts review the discovered apparent anomalies with business data consumers to see if there are any links between the data errors and any potential business impacts. By distinguishing those data errors that have material impact from the irrelevant ones, the team can prioritize issues based on business impact, and explore ways that the issues can be resolved.
- **Define measures of data quality** – correlating business impacts to data issues through defined business rules provides the method of measurement, and these measures can be used to baseline levels of data quality as well as continuous observation and inspection within an information production flow. This process guides the consideration of data measures to be performed and the technology requirements for collecting those measurements.
- **Prepare DQ assessment report** – the process of documenting the correlation of business impacts with data anomalies along with potential methods of measurement all within a single report provides a “fix-point” for the business data consumers regarding the current state of data quality, and provides the baseline for considering target levels for improvement.

### **Data Quality Measurement and Metrics**

Having used an assessment to identify areas for data quality improvement, the next step is to synthesize the results of the assessment to narrow the scope by concentrating on the data elements that are deemed critical based on the business users' needs. Defining performance metrics for reporting using a data quality scorecard requires processes for the determination of dimensions and corresponding units of measure and acceptability thresholds, and the presentation of quantifiable metrics that are relevant to the business data consumers.

To continue our example, once we have determined using the data quality assessment process that problems with addresses impacts the ability to optimally deliver shipped items, we can narrow the focus for data quality measurements to specific metrics associated with the critical data elements that contribute to the delivery failures. Some items might not be delivered due to missing street information, while others might have incorrect zip codes. The first problem is one of completeness, while the second of consistency with defined reference data. Measurements associated with the data quality dimensions of completeness and consistency can be defined using data quality validation rules for each address, and the resulting measures can be presented as metrics to the business users in the fulfillment department to estimate how invalid addresses are related to increased costs.

### **Aspects of this Practice Include:**

- **Select dimensions of data quality** – A dimension of data quality describes a context and a frame of reference for measurement along with suggested units of measurement.  
Commonly measured dimensions of data quality include completeness, consistency, timeliness, and uniqueness, although the range of possible dimensions is only limited by the ability to provide a method for measurement. During this process, the data quality analysts select the dimensions that are to be measured and consider the tools, techniques, and skills needed to capture the measurements. The result of this process is a collection of specific measures that can be combined to contribute to qualitative data quality metrics.
- **Define data quality metrics** – Having identified the dimensions of data quality that are relevant to the business data consumers as well as the dimensions and the specific measures, the analyst can create specific reportable metrics that can be presented to the business data stewards. These may be basic metrics composed of directly measured rules, or may be more complex metrics that are composed as weighted averages of collected scores. Other aspects include reporting schemas and methods for drilling into flawed data for root cause analysis.
- **Define data validity rules** – The assessment process will expose potential anomalies, which are reviewed with the business users to identify data quality measures and, ultimately, data quality metrics. Yet in order to transition away from a reactive approach that seeks to remediate data

quality issues once they are manifested at the end-user interface, the organization must engineer data controls into the application development process so that data errors can be identified and addressed as they occur. This process has the data quality analysts developing data validity rules; these rules can be integrated into the business applications as controls to verify that data meet expectations throughout the information flow.

- **Set acceptability thresholds** – Once the data quality dimensions and metrics have been validated, the business users are consulted to express their acceptability thresholds. When a metric score is below the acceptability threshold, it means that the data does not meet business expectations. Integrating these thresholds with the methods for measurement completes the construction of the data quality metric.
- **Devise data quality scorecard** – A data quality scorecard presents metric scores to the data stewards observing the business data sets. Metrics scores can be captured within a repository over a long time period to enable trending and demonstrate continuous improvement or (conversely) show that progress is not being made. The process of devising the scorecard include managing the metrics definitions, measurement processes, weightings, how the scores are captured and stored, as well as composing the tools and technologies for delivery and presentation.

### **Data Quality and the System Development Life Cycle**

Too often, data quality becomes an afterthought, with staff members reacting to discovered errors instead of proactively rooting out the causes of data flaws. Because data quality cannot just be an afterthought, once there are processes for identifying the business impact of data quality as well as the capability to define rules for inspection and monitoring, the next step is to integrate that inspection directly into the business applications. In essence, the next practice is to establish the means by which data quality management is designed and engineered across the enterprise application architecture.

However, because traditional approaches to system requirements analysis and design have concentrated on functional requirements for transactional or operational applications, the information needs of downstream business processes are ignored until long after the applications are put into production. Instead, engineering data quality management into the enterprise requires reformulating the view to requirements analysis, with a new focus on horizontal and downstream information requirements instead of solely addressing immediate functional needs.

To continue our example, with the understanding that invalid addresses lead to increased shipping costs, there are two approaches for remediation. The reactive approach is to subject all addresses to a data cleansing and enhancement process prior to generating a shipping label as a way of ensuring the best addresses. While this may result in reducing some of the increased costs, there may be records that are not correctable, or are not properly corrected. Yet if the data validity rules are known, they can be integrated directly into the application when the location data is created. In other words, validating and correcting the address when it is entered by the customer prevents invalid addresses from being introduced into the environment altogether!

#### **Processes that Contribute to this Practice Include:**

- **Data Quality requirements analysis** – during this process, the data quality analysts will synthesize data quality expectations for consumed data sets based on the business impact analysis, the determination of data quality dimensions, and aspects of prioritization related to feasibility as well as systemic impact. For each business application, the information flow is traversed backwards to the points where data is created or acquired, and the end-to-end map is investigated to determine the most appropriate points for inserting data inspection routines. At the points where data sets are extracted, transformed, or exchanged, the analysts can propose data controls that will trigger notification events when downstream expectations are violated.
- **Enhancing the SDLC for DQ** – incorporating data validation and data quality inspection and reporting into business processes and the corresponding business application by adjusting the general system development life cycle (SDLC) so that organizational data requirements can be



solicited and integrated into the requirements phase of system development. This process looks at business ownership of data, and how business process modeling can be used to elaborate on the information needs in addition to functional requirements for business operations. Since downstream users such as business intelligence reporting consumers will depend on the data collected during operational activities, there is a need to formally collect data requirements as part of the SDLC process.

- **Integrate data quality improvement methods** – capturing the organization's data quality requirements as part of the requirements and design phases of a development life cycle empower the development team in integrating data quality and data correction directly into the application. This includes the ability to validate data values and records at their entry into the environment (either through acquisition or creation) or at any hand-off between processing stages, verify acceptability, and either push invalid data back to the provider for resolution or to apply adjustments or corrections on the fly.

### **Operational Data Quality Improvement**

Having collected data quality requirements, defined data validation rules and recommended methods for measuring conformance, the next step is to establish the contract between data suppliers and data consumers as to the service level for maintaining high quality data.

In our example, addresses are validated against a set of defined data standards, either specifically managed by postal agencies in different countries, or “de facto” standards employed by delivery practitioners to ensure proper distribution. These data standards define reference tables and other metadata artifacts that can be used to actively ensure that the validity of a delivery location specification.

Combining the data validity rules and the documented metadata, the data quality analysts can document the level of acceptability for location data expected by the business users. In turn, the performance of any remediation activities can be measured to guarantee that the data is of acceptable quality.

The practice of establishing a data quality service level agreement incorporates these tasks:

- **Data Standards Management** – the absence of a common frame of reference, as well as common business term definitions and an agreed-to format for exchange makes it difficult for parties to understand each other. This is acutely true with respect to data when specific pieces of information need to be shared across two or more business applications. This suggests the need for a normalized standard for data sharing. A data standard is an agreement between collaborating parties on the definitions of common business terms, the ways those terms are named and represented in data, and a set of rules that may describe how data are stored, exchanged, formatted, or presented. This process describes the policies and procedures for defining rules and reaching agreement about standard data elements.
- **Active metadata management** – because the use of the data elements and their underlying concepts drive how the business applications will ultimately execute, an enterprise metadata repository can be used as a “control center” for driving and managing how those business applications use common data concepts. Aside from the need to collect standard technical details regarding the numerous data elements that are potentially available, a metadata repository can help when there is a need to
  - determine business uses of each data element,
  - determine which data element definitions refer to similar concepts,
  - identify the applications that refer to those data concepts,
  - review how each data element and associated concepts are created, read, modified, or retired by different applications,

- document the data quality characteristics, note the inspection and monitoring locations within the business process flow, and
- summarize how all the uses are tied together.

Therefore, a valuable component of an information architecture is an enterprise business metadata management program to facilitate the desired level of standards across the organization.

- **Data Quality inspection and monitoring** – the availability of data validation rules is the basis for data quality inspection and monitoring. Inserting inspection probes and monitoring the quality of data provides the means for identifying data flaws and for notifying the appropriate people when those data flaws are discovered so that any agreed-to remediation tasks can be initiated. Mechanisms for data inspection and monitoring and the corresponding process workflows must be defined for the purposes of inspecting data and ensuring that the data elements, records, and data sets meet downstream requirements.

This process involves defining the data quality inspection routines, which may include both automated and manual processes. Automated processes may include the results of edit checks executed during application processing, data profiling or data analysis automation, ETL tools, or customized processing. Manual inspection may require running queries or reports on data sources or even obtaining samples of data which are then examined.

Inspection procedures are defined for each relevant data quality dimension. The inspection methods are customized for each system as appropriate.

- **Define Data Quality service level agreements** – a service level agreement is a contract between a service provider and that provider's consumers that specifies the service provider's responsibilities with respect to different measurable aspects of what is being provided, such as availability, performance, response time for problems, etc. A data quality service level agreement, or DQ SLA, is an agreement that specifies data consumer expectations in terms of data validity rules and levels of acceptability, as well as reasonable expectations for response and remediation when data errors and corresponding process failures are discovered. DQ SLAs can be expressed for any situation in which a data supplier provides data to a data consumer.

This process is to specify expectations regarding measurable aspects relating to one or more dimensions of data quality (such as accuracy, completeness, consistency, timeliness, etc.), as suggested by other processes already described. Then, the service level agreement specifies what is meant by conformance to those expectations, and describes the workflow that is performed when those expectations are not met. Reported issues will be prioritized and the appropriate people in the organization will be notified to take specific actions to resolve issues before any negative business impacts can occur.

#### **Issue Tracking, Remediation, Improvement**

Operationalizing the data quality service level agreement means that there are processes for reporting, logging, and tracking emergent or discovered data quality issues. Incident reporting frameworks can be adapted to this purpose, which allows the data stewards to concentrate on evaluating the root causes of data issues and proposing a remediation plan, ranging from process reengineering to simple data corrections.

Issues tracking, logging, and management ensures that any discovered issues don't fall through the cracks. In our example, any time a shipment is returned due to a data quality problem, a data analyst will review the error to determine the source of the problem, consider whether it was due to a validation step that was not taken, or determine that there is a new root cause that can lead to defining additional validation rules that can be integrated into the business process flow.

This practice incorporates these tasks:

- **Data quality issue reporting and tracking** – enforcing a data quality service level agreement requires the processes for reporting and tracking data quality issues as well as any follow-on activities. Using a system to log and track data quality issues encourages more formal evaluation and initial diagnosis of "bad data," and the availability of a data quality issue tracking system helps



staff members be more effective at identifying and consequently fixing data-related problems. Incident tracking can also feed performance reporting such as mean-time-to-resolve issues, frequency of occurrence of issues, types of issues, sources of issues, and common approaches for correcting or eliminating problems.

- **Root cause analysis** – data validation rules used as data controls integrated within business applications can trigger notifications that a data error has occurred. At that point it is the role of the data stewards to not just correct the data, but also identify the source of the introduction of the errors into the data. The root cause analysis process employs inspection and monitoring tools and techniques to help isolate the processing phase where the error actually occurred and to review the business processes to determine the ultimate root cause of any errors.
- **Data cleansing** – remedying data errors is instinctively reactive, incorporating processes to correct errors in order to meet acceptability limits, especially when the root cause cannot be determined or if it is beyond the administrative domain of the data stewards to influence a change to the process. Corrections must be socialized and synchronized with all data consumers and data suppliers, especially when the data is used in different business contexts. For example there must be general agreement for changes when comparing reported data and rolled-up aggregate results to operational systems, because different numbers that have no explanation will lead to extra time spent attempting to reconcile the variant results.
- **Process remediation** – despite the existence of a governed mechanism for correcting bad data, the fact that errors occur implies that flawed processes must be reviewed and potentially corrected. Process correction encompasses governed process for evaluating the information production flow, business process work flow, and the determination of how processes can be improved so as to reduce or eliminate the introduction of errors.

### **Data Quality Practices and Core Data Services**

Instituting a data quality management program means more than just purchasing data cleansing tools or starting a data governance board, and establishing a good data management program takes more than just documenting a collection of processes. An iterative cycle of assessment, planning, execution, and performance management for data quality requires repeatable processes that join people with the right sets of skills with the most appropriate tools, and the staff members who are to take part in the program need to have the right kinds of tools at their disposal in order to transition from theory to actual practice. This suggests a combination of the right technology and the proper training in the use of technology, employing data services such as:

- Data integration, to ensure suitable means for extracting and transforming data between different kinds of systems.
- Data profiling, used for data quality assessment, data Validation, and inspection and monitoring.
- Parsing and standardization and identity resolution, which is used for data validation, identification of data errors, normalization, and data correction.
- Record linkage and merging, also used to identify data errors and for resolving variance and subsequent data correction.

These are a subset of the core data services for standardizing sound data management practices. Standardizing the way data quality is deployed and using the right kinds of tools will ensure predictable information reliability and value. When developing or reengineering the enterprise architecture, implementing the fundamental data quality practices will ultimately reduce the complexity of the data management framework, thereby reducing effort, lowering risk, and leading to a high degree of trust in enterprise information.

### 7.3 ARTIFICIAL NEURAL NETWORK (ANN)

An Artificial Neural Network (ANN) is a mathematical model that tries to simulate the structure and functionalities of biological neural networks. Basic building block of every artificial neural network is artificial neuron, that is, a simple mathematical model (function). Such a model has three simple sets of rules: multiplication, summation and activation. At the entrance of artificial neuron the inputs are weighted what means that every input value is multiplied with individual weight. In the middle section of artificial neuron is sum function that sums all weighted inputs and bias. At the exit of artificial neuron the sum of previously weighted inputs and bias is passing through activation function that is also called transfer function.

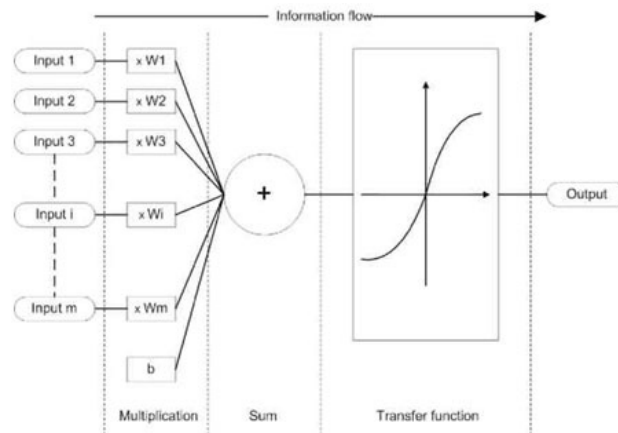

**Fig. Working Principle of an Artificial Neuron**

Although the working principles and simple set of rules of artificial neuron looks like nothing special the full potential and calculation power of these models come to life when we start to interconnect them into artificial neural networks. These artificial neural networks use simple fact that complexity can grown out of merely few basic and simple rules.

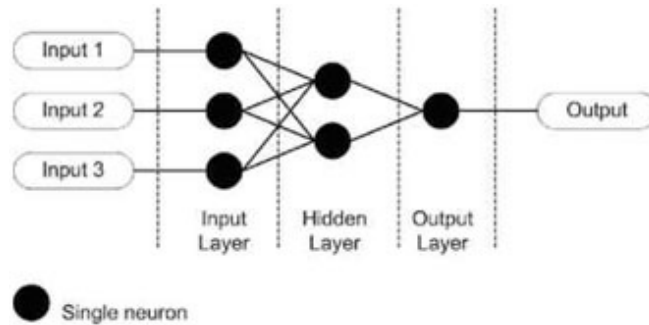

**Fig. Example of Simple Artificial Neural Network**

In order to fully harvest the benefits of mathematical complexity that can be achieved through interconnection of individual artificial neurons and not just making system complex and unmanageable we usually do not interconnect these artificial neurons randomly. In the past, researchers have come up with several "standardised" topographies of artificial neural networks. These predefined topographies can help us with easier, faster and more efficient problem solving. Different types of artificial neural network topographies are suited for solving different types of problems. After determining the type of given problem we need to decide for topology of artificial neural network we are going to use and then fine-tune it. We need to fine-tune the topology itself and its parameters. Fine tuned topology of artificial neural network does not mean that we can start using our artificial neural network, it is only a

precondition. Before we can use our artificial neural network we need to teach it solving the type of given problem. Just as biological neural networks can learn their behaviour/responses on the basis of inputs that they get from their environment the artificial neural networks can do the same. There are three major learning paradigms: supervised learning, unsupervised learning and reinforcement learning. We choose learning paradigm similar as we chose artificial neuron network topography - based on the problem we are trying to solve. Although learning paradigms are different in their principles they all have one thing in common; on the basis of "learning data" and "learning rules" (chosen cost function) artificial neural network is trying to achieve proper output response in accordance to input signals.

After choosing topology of an artificial neural network, fine-tuning of the topology and when artificial neural network has learn a proper behaviour we can start using it for solving given problem. Artificial neural networks have been in use for some time now and we can find them working in areas such as process control, chemistry, gaming, radar systems, automotive industry, space industry, astronomy, genetics, banking, fraud detection, etc. and solving of problems like function approximation, regression analysis, time series prediction, classification, pattern recognition, decision making, data processing, filtering, clustering, etc., naming a few.

### 7.3.1 Artificial Neuron

Artificial neuron is a basic building block of every artificial neural network. Its design and functionalities are derived from observation of a biological neuron that is basic building block of biological neural networks (systems) which includes the brain, spinal cord and peripheral ganglia. Similarities in design and functionalities can be seen in the figure below, where the left side of a figure represents a biological neuron with its soma, dendrites and axon and where the right side of a figure represents an artificial neuron with its inputs, weights, transfer function, bias and outputs.

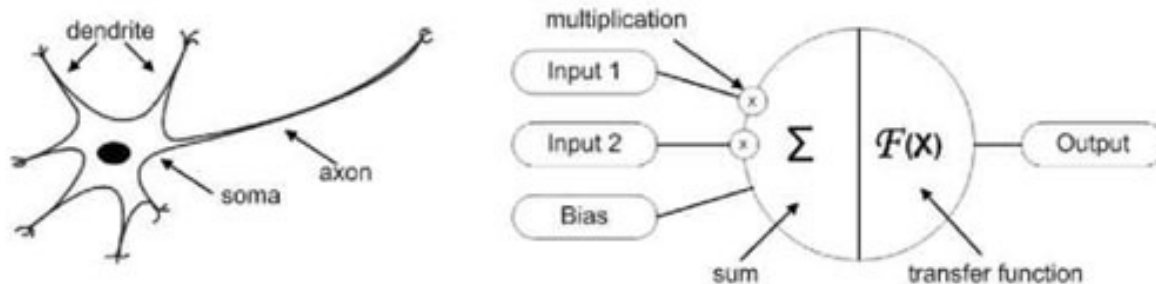

**Fig. Biological and Artificial Neuron Design**

In case of biological neuron information comes into the neuron via dendrite, soma processes the information and passes it on via axon. In case of artificial neuron the information comes into the body of an artificial neuron via inputs that are weighted (each input can be individually multiplied with a weight). The body of an artificial neuron then sums the weighted inputs, bias and "processes" the sum with a transfer function. At the end an artificial neuron passes the processed information via output(s). Benefit of artificial neuron model simplicity can be seen in its mathematical description below:

$$y(k) = F \left( \sum_{i=0}^m w_i(k) x_i(k) + b \right) \quad (1)$$

Where:

- $X_i(k)$  is input value in discrete time  $k$  where  $i$  goes from 0 to  $m$ ,
- $W_i(k)$  is weight value in discrete time  $k$  where  $i$  goes from 0 to  $m$ ,
- $b$  is bias,
- $F$  is a transfer function,



- $y_i(k)$  is output value in discrete time  $k$ .

As seen from a model of an artificial neuron and its equation (1) the major unknown variable of our model is its transfer function. Transfer function defines the properties of artificial neuron and can be any mathematical function. We choose it on the basis of problem that artificial neuron (artificial neural network) needs to solve and in most cases we choose it from the following set of functions: Step function, Linear function and Non-linear (Sigmoid) function.

Step function is binary function that has only two possible output values (e.g. zero and one). That means if input value meets specific threshold the output value results in one value and if specific threshold is not meet that results in different output value. Situation can be described with equation (2).

$$y = \begin{cases} 1 & \text{if } w_i x_i \geq \text{threshold} \\ 0 & \text{if } w_i x_i < \text{threshold} \end{cases} \quad (2)$$

When this type of transfer function is used in artificial neuron we call this artificial neuron perceptron. Perceptron is used for solving classification problems and as such it can be most commonly found in the last layer of artificial neural networks. In case of linear transfer function artificial neuron is doing simple linear transformation over the sum of weighted inputs and bias. Such an artificial neuron is in contrast to perceptron most commonly used in the input layer of artificial neural networks. When we use non-linear function the sigmoid function is the most commonly used. Sigmoid function has easily calculated derivate, which can be important when calculating weight updates in the artificial neural network.

### 7.3.2 Some Issues related to Artificial Neural Networks

When combining two or more artificial neurons we are getting an artificial neural network. If single artificial neuron has almost no usefulness in solving real-life problems the artificial neural networks have it. In fact artificial neural networks are capable of solving complex real-life problems by processing information in their basic building blocks (artificial neurons) in a non-linear, distributed, parallel and local way.

The way that individual artificial neurons are interconnected is called topology, architecture or graph of an artificial neural network. The fact that interconnection can be done in numerous ways results in numerous possible topologies that are divided into two basic classes. The following figure shows these two topologies; the left side of the figure represent simple feed forward topology (acyclic graph) where information flows from inputs to outputs in only one direction and the right side of the figure represent simple recurrent topology (semi-cyclic graph) where some of the information flows not only in one direction from input to output but also in opposite direction. While observing the following figure we need to mention that for easier handling and mathematical describing of an artificial neural network we group individual neurons in layers. On the following figure we can see input, hidden and output layer.

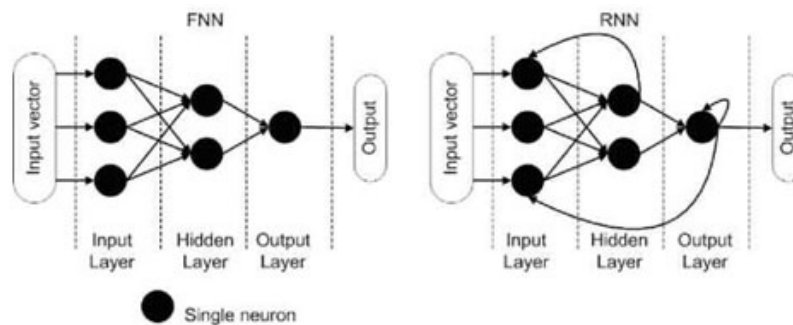

Fig. Feed-forward (FNN) and recurrent (RNN) topology of an artificial

When we choose and build topology of our artificial neural network we only finished half of the task before we can use this artificial neural network for solving given problem. Just as biological neural networks need to learn their proper responses to the given inputs from the environment the artificial neural networks need to do the same. So the next step is to learn proper response of an artificial neural network and this can be achieved through learning (supervised, un-supervised or reinforcement learning). No matter which method we use, the task of learning is to set the values of weight and biases on basis of learning data to minimize the chosen cost function.

### 7.3.3 Feed-forward Artificial Neural Networks

Artificial neural network with feed-forward topology is called Feed-Forward artificial neural network and as such has only one condition: information must flow from input to output in only one direction with no back-loops. There are no limitations on number of layers, type of transfer function used in individual artificial neuron or number of connections between individual artificial neurons. The simplest feed-forward artificial neural network is a single perceptron that is only capable of learning linear separable problems. Simple multi-layer feed-forward artificial neural network for purpose of analytical description (sets of equations (3), (4) and (5)) is shown on the following figure.

$$\begin{aligned} n_1 &= F_1 (w_1 x_1 + b_1) \\ n_2 &= F_2 (w_2 x_2 + b_2) \\ n_3 &= F_2 (w_2 x_2 + b_2) \\ n_4 &= F_3 (w_3 x_3 + b_3) \end{aligned} \quad (3)$$

$$\begin{aligned} m_1 &= F_4 (q_1 n_1 + q_2 n_2 + b_4) \\ m_2 &= F_4 (q_3 n_3 + q_4 n_4 + b_5) \\ y &= F_6 (r_1 m_1 + r_2 m_2 + b_6) \end{aligned} \quad (4)$$

$$y = F_6 \left[ r_1 F_4 [q_1 F_1 [w_1 x_1 + b_1] + q_2 F_2 [w_2 x_2 + b_2]] + b_4 + r_2 F_4 [q_3 F_2 [w_2 x_2 + b_2] + q_4 F_3 [w_3 x_3 + b_3]] + b_5 \right] + b_6 \quad (5)$$

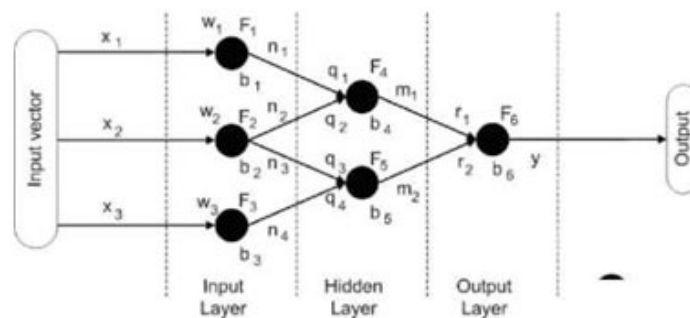

$x, n, m, y$  - signals  $w, q, r$  - weights  $F$  - transfer functions  $b$  - biases

Fig. Feed-forward artificial neural network.

As seen on the previous figure and corresponding analytical description with sets of equations (3), (4) and (5) the simple feed-forward artificial neural network can lead to relatively long mathematical descriptions where artificial neural networks' parameters optimization problem solving by hand is impractical. Although analytical description can be used on any complex artificial neural network in practise we use computers and specialised software that can help us build, mathematically describe and optimise any type of artificial neural network.

### 7.3.4 Recurrent Artificial Neural Networks

Artificial neural network with the recurrent topology is called Recurrent artificial neural network. It is similar to feed-forward neural network with no limitations regarding back-loops. In these cases information is no longer transmitted only in one direction but it is also transmitted backwards. This creates an internal state of the network which allows it to exhibit dynamic temporal behaviour. Recurrent artificial neural networks can use their internal memory to process any sequence of inputs. The following figure shows small Fully Recurrent artificial neural network and complexity of its artificial neuron interconnections. The most basic topology of recurrent artificial neural network is fully recurrent artificial network where every basic building block (artificial neuron) is directly connected to every other basic building block in all direction. Other recurrent artificial neural networks such as Hopfield, Elman, Jordan, bi-directional and other networks are just special cases of recurrent artificial neural networks.

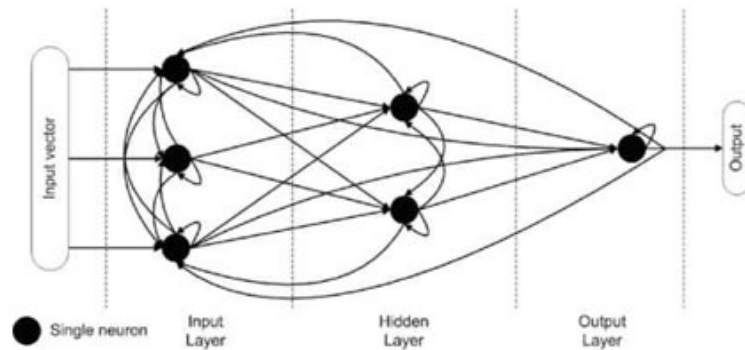

Fig. Fully recurrent artificial neural network

### 7.3.5 Hopfield Artificial Neural Network

A Hopfield artificial neural network is a type of recurrent artificial neural network that is used to store one or more stable target vectors. These stable vectors can be viewed as memories that the network recalls when provided with similar vectors that act as a cue to the network memory. These binary units only take two different values for their states that are determined by whether or not the units' input exceeds their threshold. Binary units can take either values of 1 or -1, or values of 1 or 0. Consequently there are two possible definitions for binary unit activation  $a_i$  (equation (6) and (7)):

$$a_j = \begin{cases} -1 & \text{if } \sum_j w_j s_j > \theta_j \\ 1 & \text{otherwise.} \end{cases} \quad (6)$$

$$a_j = \begin{cases} -1 & \text{if } \sum_j w_j s_j > \theta_j \\ 1 & \text{otherwise.} \end{cases} \quad (7)$$

Where:

- $w_{ij}$  is the strength of the connection weight from unit j to unit i,
- $s_j$  is the state of unit j,
- $\theta_i$  is the threshold of unit i.

While talking about connections  $w_{ij}$  we need to mention that there are typical two restrictions: no unit has a connection with itself ( $w_{ij}$ ) and that connections are symmetric  $w_{ij} = w_{ji}$ .

The requirement that weights must be symmetric is typically used, as it will guarantee that the energy function decreases monotonically while following the activation rules. If non-symmetric weights are used the network may exhibit some periodic or chaotic behaviour. Training a Hopfield artificial neural network involves lowering the energy of states that the artificial neural network should remember.

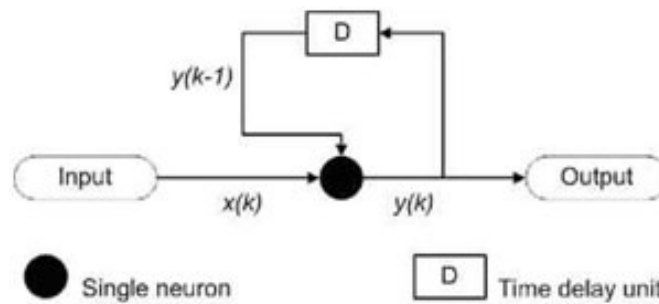
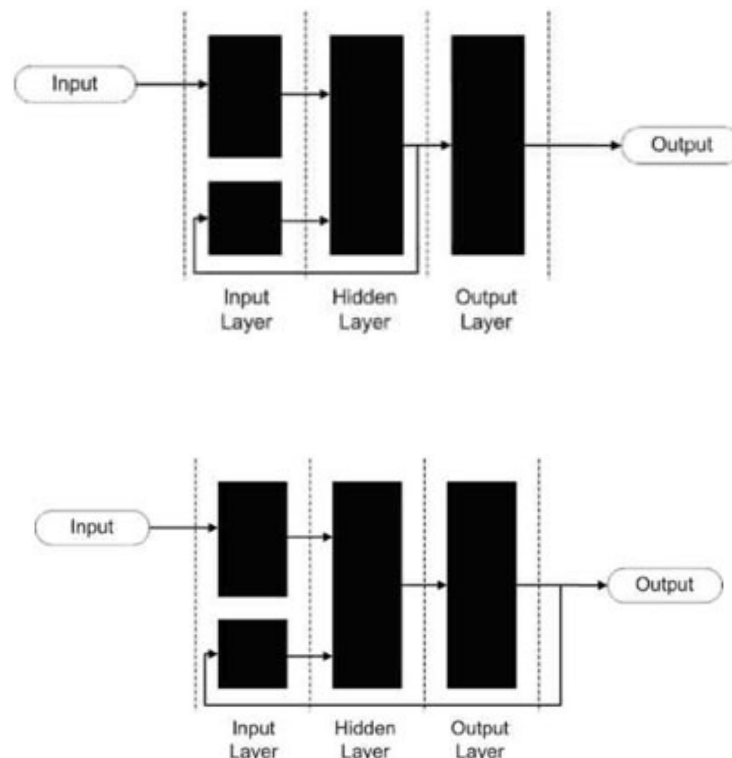

**Fig. Simple “one neuron” Hopfield artificial neural network**

### 7.3.6 Elman and Jordan Artificial Neural Networks

Elman network also referred as Simple Recurrent Network is special case of recurrent artificial neural networks. It differs from conventional two-layer networks in that the first layer has a recurrent connection. It is a simple three-layer artificial neural network that has back-loop from hidden layer to input layer through so called context unit. This type of artificial neural network has memory that allowing it to both detect and generate time-varying patterns.

The Elman artificial neural network has typically sigmoid artificial neurons in its hidden layer, and linear artificial neurons in its output layer. This combination of artificial neurons transfer functions can approximate any function with arbitrary accuracy if only there is enough artificial neurons in hidden layer. Being able to store information Elman artificial neural network is capable of generating temporal patterns as well as spatial patterns and responding on them. Jordan network is similar to Elman network. The only difference is that context units are fed from the output layer instead of the hidden layer.

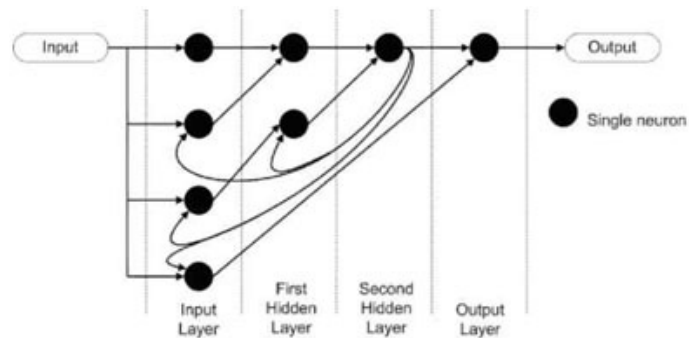

**Fig. Jordan artificial neural network**

### 7.3.7 Long Short Term Memory

Long Short Term Memory is one of the recurrent artificial neural networks topologies. In contrast with basic recurrent artificial neural networks it can learn from its experience to process, classify and predict time series with very long time lags of unknown size between important events. This makes Long Short Term Memory to outperform other recurrent artificial neural networks, Hidden Markov Models and other sequence learning methods. Long Short Term Memory artificial neural network is build from Long Short Term Memory blocks that are capable of remembering value for any length of time. This is achieved with gates that determine when the input is significant enough remembering it, when continue to remembering or forgetting it, and when to output the value.

Architecture of Long Short Term Memory block is shown in the following figure where input layer consists of sigmoid units. Top neuron in the input layer process input value that might be sent to a memory unit depends on computed value of second neuron from the top in the input layer. The third neuron from the top in the input layer decide how long will memory unit hold (remember) its value and the bottom most neuron determines when value from memory should be released to the output. Neurons in first hidden layer and in output layer are doing simple multiplication of their inputs and a neuron in the second hidden layer computes simple linear function of its inputs. Output of the second hidden layer is fed back into input and first hidden layer in order to help making decisions.



**Fig. Simple Long Short Term Memory artificial neural network (block)**

### 7.3.8 Bi-directional Artificial Neural Networks (Bi-ANN)

Bi-directional artificial neural networks are designed to predict complex time series. They consist of two individual interconnected artificial neural (sub) networks that performs direct and inverse (bidirectional) transformation. Interconnection of artificial neural sub networks is done through two dynamic artificial neurons that are capable of remembering their internal states. This type of interconnection between future and past values of the processed signals increase time series prediction capabilities. As such these artificial neural networks not only predict future values of input data but also past values. That brings need for two phase learning; in first phase we teach one artificial neural sub network for predicting future and in the second phase we teach a second artificial neural sub network for predicting past.

### 7.3.9 Self-Organizing Map (SOM)

Self-organizing map is an artificial neural network that is related to feed-forward networks but it needs to be told that this type of architecture is fundamentally different in arrangement of neurons and motivation. Common arrangement of neurons is in a hexagonal or rectangular grid. Self-organizing map is different in comparison to other artificial neural networks in the sense that they use a neighbourhood function to preserve the topological properties of the input space. They uses unsupervised learning paradigm to produce a low-dimensional, discrete representation of the input space of the training samples, called a map what makes them especially useful for visualizing low-dimensional views of high-dimensional data. Such networks can learn to detect regularities and correlations in their input and adapt their future responses to that input accordingly.

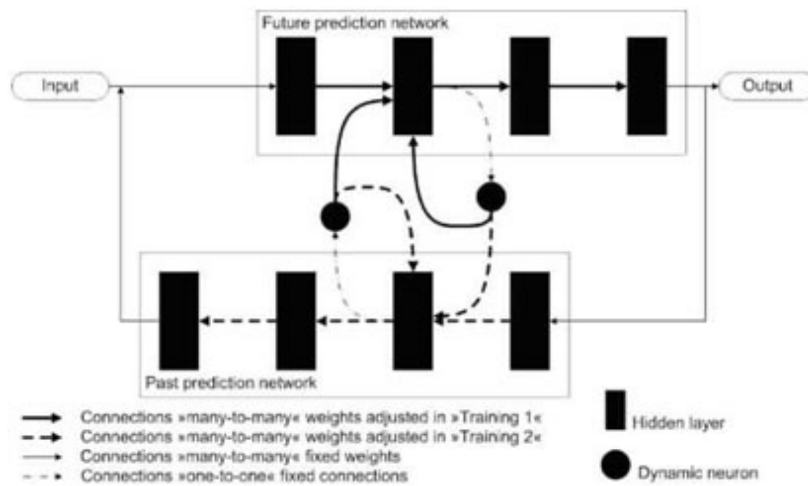

**Fig. Bi-directional artificial neural network**

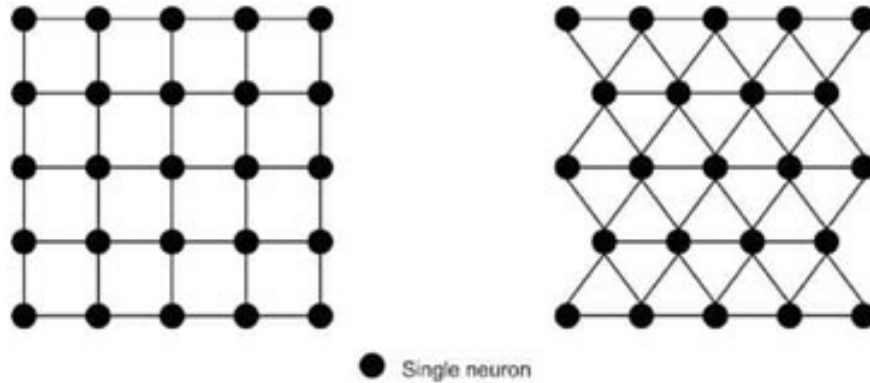

**Fig. Self-organizing Map in rectangular (left) and hexagonal (right) grid**

Just as others artificial neural networks need learning before they can be used the same goes for self-organizing map; where the goal of learning is to cause different parts of the artificial neural network to respond similarly to certain input patterns. While adjusting the weights of the neurons in the process of learning they are initialized either to small random values or sampled evenly from the subspace spanned by the two largest principal component eigenvectors. After initialization artificial neural network needs to be fed with large number of example vectors. At that time Euclidean distance to all weight vectors is computed and the neuron with weight vector most similar to the input is called the best matching unit. The weights of the best matching unit and neurons close to it are adjusted towards the input vector. This process is repeated for each input vector for a number of cycles. After learning phase we do so-called mapping (usage of artificial neural network) and during this phase the only one neuron whose weight vector lies closest to the input vector will be winning neuron. Distance between input and weight vector is again determined by calculating the Euclidean distance between them.

### 7.3.10 Stochastic Artificial Neural Network

Stochastic artificial neural networks are a type of an artificial intelligence tool. They are built by introducing random variations into the network, either by giving the network's neurons stochastic transfer functions, or by giving them stochastic weights. This makes them useful tools for optimization problems, since the random fluctuations help it escape from local minima. Stochastic neural networks that are built by using stochastic transfer functions are often called Boltzmann machine.

### **7.3.11 Physical Artificial Neural Network**

Most of the artificial neural networks today are software-based but that does not exclude the possibility to create them with physical elements which base on adjustable electrical current resistance materials. History of physical artificial neural networks goes back in 1960's when first physical artificial neural networks were created with memory transistors called memistors. Memistors emulate synapses of artificial neurons. Although these artificial neural networks were commercialized they did not last for long due to their incapability for scalability. After this attempt several others followed such as attempt to create physical artificial neural network based on nanotechnology or phase change material.

### **7.3.12 Learning**

There are three major learning paradigms; supervised learning, unsupervised learning and reinforcement learning. Usually they can be employed by any given type of artificial neural network architecture. Each learning paradigm has many training algorithms.

### **7.3.13 Supervised Learning**

Supervised learning is a machine learning technique that sets parameters of an artificial neural network from training data. The task of the learning artificial neural network is to set the value of its parameters for any valid input value after having seen output value. The training data consist of pairs of input and desired output values that are traditionally represented in data vectors. Supervised learning can also be referred as classification, where we have a wide range of classifiers, each with its strengths and weaknesses. Choosing a suitable classifier (Multilayer perceptron, Support Vector Machines, k-nearest neighbour algorithm, Gaussian mixture model, Gaussian, naive Bayes, decision tree, radial basis function classifiers,...) for a given problem is however still more an art than a science. In order to solve a given problem of supervised learning various steps has to be considered. In the first step we have to determine the type of training examples. In the second step we need to gather a training data set that satisfactory describe a given problem. In the third step we need to describe gathered training data set in form understandable to a chosen artificial neural network. In the fourth step we do the learning and after the learning we can test the performance of learned artificial neural network with the test (validation) data set. Test data set consist of data that has not been introduced to artificial neural network while learning.

### **7.3.14 Unsupervised Learning**

Unsupervised learning is a machine learning technique that sets parameters of an artificial neural network based on given data and a cost function which is to be minimized. Cost function can be any function and it is determined by the task formulation. Unsupervised learning is mostly used in applications that fall within the domain of estimation problems such as statistical modelling, compression, filtering, blind source separation and clustering. In unsupervised learning we seek to determine how the data is organized. It differs from supervised learning and reinforcement learning in that the artificial neural network is given only unlabeled examples. One common form of unsupervised learning is clustering where we try to categorize data in different clusters by their similarity. Among above described artificial neural network models, the Self-organizing maps are the ones that the most commonly use unsupervised learning algorithms.

### **7.3.15 Reinforcement Learning**

Reinforcement learning is a machine learning technique that sets parameters of an artificial neural network, where data is usually not given, but generated by interactions with the environment. Reinforcement learning is concerned with how an artificial neural network ought to take actions in an environment so as to maximize some notion of long-term reward. Reinforcement learning is frequently used as a part of artificial neural network's overall learning algorithm.

After return function that needs to be maximized is defined, reinforcement learning uses several algorithms to find the policy which produces the maximum return. Naive brute force algorithm in first step calculates return function for each possible policy and chooses the policy with the largest return.

Obvious weakness of this algorithm is in case of extremely large or even infinite number of possible policies. This weakness can be overcome by value function approaches or direct policy estimation. Value function approaches attempt to find a policy that maximizes the return by maintaining a set of estimates of expected returns for one policy; usually either the current or the optimal estimates. These methods converge to the correct estimates for a fixed policy and can also be used to find the optimal policy. Similar as value function approaches the direct policy estimation can also find the optimal policy. It can find it by searching it directly in policy space what greatly increases the computational cost.

Reinforcement learning is particularly suited to problems which include a long-term versus short-term reward trade-off. It has been applied successfully to various problems, including robot control, telecommunications, and games such as chess and other sequential decision making tasks.

### **7.3.16 Usage of Artificial Neural Networks**

One of the greatest advantages of artificial neural networks is their capability to learn from their environment. Learning from the environment comes useful in applications where complexity of the environment (data or task) make implementations of other type of solutions impractical. As such artificial neural networks can be used for variety of tasks like classification, function approximation, data processing, filtering, clustering, compression, robotics, regulations, decision making, etc. Choosing the right artificial neural network topology depends on the type of the application and data representation of a given problem. When choosing and using artificial neural networks we need to be familiar with theory of artificial neural network models and learning algorithms. Complexity of the chosen model is crucial; using too simple model for specific task usually results in poor or wrong results and over complex model for a specific task can lead to problems in the process of learning. Complex model and simple task results in memorizing and not learning. There are many learning algorithms with numerous tradeoffs between them and almost all are suitable for any type of artificial neural network model. Choosing the right learning algorithm for a given task takes a lot of experiences and experimentation on given problem and data set. When artificial neural network model and learning algorithm is properly selected we get robust tool for solving given problem.

#### **Example: Using bi-directional artificial neural network for ICT fraud detection**

Spread of Information and Communication Technologies results in not only benefits for individuals and society but also in threats and increase of Information and Communication Technology frauds. One of the main tasks for Information and Communication Technology developers is to prevent potential fraudulent misuse of new products and services. If protection against fraud fails there is a vital need to detect frauds as soon as possible. Information and Communication Technology frauds detection is based on numerous principles. One of such principle is use of artificial neural networks in the detection algorithms. Below is an example of how to use bi-directional artificial neural network for detecting mobile-phone fraud.

First task is to represent problem of detecting our fraud in the way that can be easily understood by humans and machines (computers). Each individual user or group of users behave in specific way while using mobile phone. By learning their behaviour we can teach our system to recognize and predict users' future behaviour to a certain degree of accuracy. Later comparison between predicted and real-life behaviour and potential discrepancy between them can indicate a potential fraudulent behaviour. It was shown that mobile-phone usage behaviour can be represented in the form of time series suitable for further analysis with artificial neural networks (Krenker et al., 2009). With this representation we transform the behaviour prediction task in time series prediction task. Time series prediction task can be realized with several different types of artificial neural networks but as mentioned in earlier chapters some are more suitable than others. Because we expect long and short time periods between important events in our data representation of users' behaviour the most obvious artificial neural networks to use are Long Short Term Memory and bi-directional artificial neural networks. On the basis of others researchers' favourable results in time series prediction with bi-directional artificial neural network (Wakuya & Shida, 2001) we decided to use this artificial neural network topology for predicting



our time series. After we choose artificial neural network architecture we choose the type of learning paradigm; we choose supervised learning where we gather real life data form telecommunication system. Gathered data was divided into two sub-sets; training sub-set and validation subset. With training data sub-set artificial neural network learn to predict future and past time series and with validation data sub-set we simulate and validate the prediction capabilities of designed and fine-tuned bi-directional artificial neural networks. Validation was done with calculation of the Average Relative Variance that represents a measure of similarity between predicted and expected time series.

Only after we gathered information about mobile-phone fraud and after choosing representation of our problem and basic approaches for solving it we could start building the overall model for detecting mobile-phone fraud.

On the following figure we can see that mobile-phone fraud detection model is build out of three modules; input module, artificial neural network module and comparison module. Input Module gathers users' information about usage of mobile-phone from telecommunication system in three parts. In first part it is used for gathering learning data from which Artificial Neural Network Module learn it-self. In second part Input Module gathers users' data for purpose of validating the Artificial Neural Network Module and in the third part it collects users' data in real time for purpose of using deployed mobile-phone fraud system. Artificial Neural Network Module is bidirectional artificial neural network that is learning from gathered data and later when the mobile-phone fraud detection system is deployed continuously predicts time series that represents users' behaviour. Comparison module is used for validation of Artificial Neural Network Module in the process of learning and later when the mobile-phone fraud detection system is deployed it is used for triggering alarms in case of discrepancies between predicted and real-life gathered information about users' behaviour.

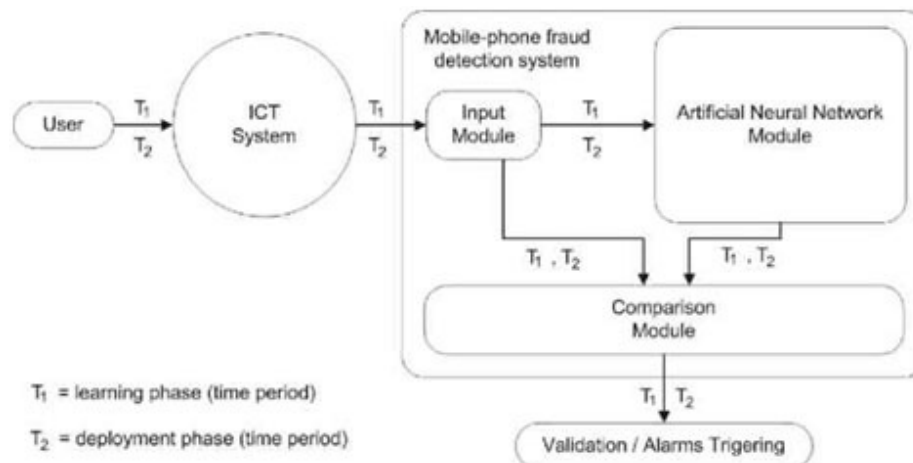

**Fig. Mobile-phone fraud detection model**

Although mobile-phone fraud detection system described above is simple and straight forward reader needs to realize that majority of work is not in creating and later implementing desired systems but in fine-tuning of data representation and artificial neural network architecture and its parameters that is strongly dependant on type of input data.

Artificial neural networks are widely spread and used in everyday services, products and applications. Although modern software products enable relatively easy handling with artificial neural networks, their creation, optimisation and usage in real-life situations it is necessary to understand theory that stands behind them. This chapter of the book introduces artificial neural networks to novice reader and serves as a stepping stone for all of those who would like to get more involved in the area of artificial neural networks. In the Introduction in order to lighten the area of artificial neural networks we briefly described basic building blocks (artificial neuron) of artificial neural networks and their "transformation" from single artificial neuron to complete artificial neural network. In the chapter Artificial Neuron we present basic



and important information about artificial neuron and where researchers borrowed the idea to create one. We show the similarities between biological and artificial neuron their composition and inner workings. In the chapter Artificial Neural Networks we describe basic information about different, most commonly used artificial neural networks topologies. We described Feed-forward, Recurrent, Hopfield, Elman, Jordan, Long Short Term Memory, Bi-directional, Self Organizing Maps, Stochastic and Physical artificial neural networks. After describing various types of artificial neural networks architectures we describe how to make them useful by learning. We describe different learning paradigms (supervised, unsupervised and reinforcement learning) in chapter Learning. In the last chapter Usage of Artificial Neural Networks we describe how to handle artificial neural networks in order to make them capable of solving certain problems. In order to show what artificial neural networks are capable of, we gave a short example how to use bi-directional artificial neural network in mobile-phone fraud detection system.

## 7.4 SIX SIGMA

Six Sigma at many organizations simply means a measure of quality that strives for near perfection. Six Sigma is a disciplined, data-driven approach and methodology for eliminating defects (driving toward six standard deviations between the mean and the nearest specification limit) in any process – from manufacturing to transactional and from product to service.

The statistical representation of Six Sigma describes quantitatively how a process is performing. To achieve Six Sigma, a process must not produce more than 3.4 defects per million opportunities. A Six Sigma defect is defined as anything outside of customer specifications. A Six Sigma opportunity is then the total quantity of chances for a defect.

The fundamental objective of the Six Sigma methodology is the implementation of a measurement-based strategy that focuses on process improvement and variation reduction through the application of Six Sigma improvement projects. This is accomplished through the use of two Six Sigma sub-methodologies: DMAIC and DMADV. The Six Sigma DMAIC process (define, measure, analyze, improve, control) is an improvement system for existing processes falling below specification and looking for incremental improvement. The Six Sigma DMADV process (define, measure, analyze, design, verify) is an improvement system used to develop new processes or products at Six Sigma quality levels. It can also be employed if a current process requires more than just incremental improvement. Both Six Sigma processes are executed by Six Sigma Green Belts and Six Sigma Black Belts, and are overseen by Six Sigma Master Black Belts.

### **Six Sigma doctrine demands the following conditions :**

- Continuous efforts to achieve stable and predictable process results (i.e., reduce process variation) are of vital importance to business success.
- Manufacturing and business processes have characteristics that can be measured, analyzed, controlled and improved.
- Achieving sustained quality improvement requires commitment from the entire organization, particularly from top-level management.

### **Six Sigma initiatives include:**

- A clear focus on achieving measurable and quantifiable financial returns from any Six Sigma project.
- An increased emphasis on strong and passionate management leadership and support. A special infrastructure of “Champions”, “Master Black Belts”, “Black Belts”, “Green Belts”, etc. to lead and implement the Six Sigma approach.
- A clear commitment to making decisions on the basis of verifiable data and statistical methods, rather than assumptions and guesswork.

Six Sigma projects follow two project methodologies inspired by Deming's Plan-Do-Check-Act Cycle. These methodologies, composed of five phases each, bear the acronyms DMAIC and DMADV.

#### 7.4.1 DMAIC

The DMAIC project methodology has five phases:

- **D**efine the problem, the voice of the customer, and the project goals, specifically.
- **M**easure key aspects of the current process and collect relevant data.
- **A**nalyze the data to investigate and verify cause-and-effect relationships. Determine what the relationships are, and attempt to ensure that all factors have been considered. Seek out root cause of the defect under investigation.
- **I**mprove or optimize the current process based upon data analysis using techniques such as design of experiments, poka yoke or mistake proofing, and standard work to create a new, future state process. Set up pilot runs to establish process capability.
- **C**ontrol the future state process to ensure that any deviations from target are corrected before they result in defects. Implement control systems such as statistical process control, production boards, visual workplaces, and continuously monitor the process.

Some organizations add a **R**ecognize step at the beginning, which is to recognize the right problem to work on, thus yielding an RDMAIC methodology.

#### 7.4.2 DMADV or DFSS

The DMADV project methodology, known as DFSS ("Design For Six Sigma"), features five phases:

- Define design goals that are consistent with customer demands and the enterprise strategy.
- Measure and identify CTQs (characteristics that are Critical To Quality), product capabilities, production process capability, and risks.
- Analyze to develop and design alternatives
- Design an improved alternative, best suited per analysis in the previous step
- Verify the design, set up pilot runs, implement the production process and hand it over to the process owner(s).

One key innovation of Six Sigma involves the "professionalizing" of quality management functions. Prior to Six Sigma, quality management in practice was largely relegated to the production floor and to statisticians in a separate quality department. Formal Six Sigma programs adopt a ranking terminology (similar to some martial arts systems) to define a hierarchy (and career path) that cuts across all business functions.

#### 7. 4.3 Six Sigma Identifies Several Key Roles for its Successful Implementation

- Executive Leadership includes the CEO and other members of top management who are responsible for setting up a vision for Six Sigma implementation. They also empower the other role holders with the freedom and resources to explore new ideas for breakthrough improvements.
- Champions take responsibility for Six Sigma implementation across the organization in an integrated manner. The Executive Leadership draws them from upper management. Champions also act as mentors to Black Belts.
- Master Black Belts, identified by champions, act as in-house coaches on Six Sigma. They devote 100% of their time to Six Sigma. They assist champions and guide Black Belts and Green Belts. Apart from statistical tasks, they spend their time on ensuring consistent application of Six Sigma across various functions and departments.
- Black Belts operate under Master Black Belts to apply Six Sigma methodology to specific projects. They devote 100% of their time to Six Sigma. They primarily focus on Six Sigma project execution, whereas Champions and Master Black Belts focus on identifying projects/functions for Six Sigma.



- Green Belts are the employees who take up Six Sigma implementation along with their other job responsibilities, operating under the guidance of Black Belts.

The term "six sigma process" comes from the notion that if one has six standard deviations between the process mean and the nearest specification limit, as shown in the graph, practically no items will fail to meet specifications. This is based on the calculation method employed in process capability studies.

Capability studies measure the number of standard deviations between the process mean and the nearest specification limit in sigma units, represented by the Greek letter  $\sigma$  (sigma). As process standard deviation goes up, or the mean of the process moves away from the center of the tolerance, fewer standard deviations will fit between the mean and the nearest specification limit, decreasing the sigma number and increasing the likelihood of items outside specification.

- **Case Study : Bank Deposits: A Black Belt**

In early 2000, dot-coms were all the rage. Any idea even remotely related to the ability to transact online was immediately funded. Consequently, many decisions were made quickly and without supporting data. And many of these decisions were made in error – but could Six Sigma have made a difference? This case study will review how a Black Belt entered a dot-com transactional business, reviewed a process, and came to his own conclusions about process performance.

- **Case Study: Online Banking**

The Black Belt began working at online bank, and his first project involved the process of how deposits were made to this bank. Since it was an "online" bank, there were no branches for customers to use. Instead, deposits were mailed using the United States Postal Service (USPS). Savings resulting from the lack of branches and tellers were passed along to the customer in the form of higher rates, free services, etc.

Customer focus groups and surveys indicated that the process of making a deposit is of critical importance to a customer. The process from the customer's viewpoint is very straightforward – they sign a check, fill out a deposit slip, and mail both to the bank. Deposits were the second largest driver of inquiries to the customer call center (13 percent of all calls). Customers expressed frustration in mailing delays and couldn't understand why their checks took so long to post to their account.

### **The Deposit Process**

The bank's mission was to receive the deposits as quickly as possible and begin the deposit and check clearing cycle. When the bank originally set up the processes, a decision was made to establish 'local' deposit locations around the United States. These local deposit locations received the deposits and overnight express reshipped them to a central processing location daily.

This local receipt and express reshipment to a central location was done for two main reasons:

1. A deposit being mailed to a local location would take less time than mailing to a centralized, national location.
2. Customer input indicated that mailing within a state or to a neighboring state would make customers more comfortable than mailing to a centralized, national location somewhere across the United States.

### **The DMAIC Project**

The Black Belt hit the ground running. A project charter was created identifying exactly what the process entailed. The business case was written, the problem statement crafted and the scope clearly identified. The team was formed and quickly moved into the measurement phase. Data surrounding the deposits was collected and the analyze phase began to yield some alarming results.

Intuition led the leaders of the business to set up a system that locally collected deposits for express

reshipment to a centralized, national location for processing. How could mailing to a centralized, national location be quicker than mailing locally and express reshipping? Why would customers not feel more comfortable mailing locally than to a centralized, national location?

### **Data and Root Causes**

Data collection, however, revealed a few flaws that were not originally identified: The express reshipment process was manual. Manual processes that are not reinforced daily and that do not have adequate control plans tend to break down. That is exactly what occurred with the local deposit locations. Some locations would not receive deposits on a daily basis. When deposits were received, they sometimes would not be express reshipped that night because of a lack of engrained process.

For deposits that were received during the week, the express reshipment process functioned properly. On the weekend, however, express reshipment wasn't possible, so deposits arriving on Saturday were not express reshipped until Monday evening.

Because of USPS processes, some deposit mailings to 'local' deposit locations took as long as three days. Tack on a weekend stay for the above listed bullet, and a deposit made via mail to a 'local' deposit location may take longer than five days just to be received by the bank.

### **Additional Findings**

An additional analysis of deposits made to a 'local' deposit location with express reshipment to a national location versus mailing directly to a centralized, national location yielded the following results:

- The 'local' process operates at a 2.1 sigma level, while the centralized, national process operates at a 2.5 sigma.
- A 2 sample t-test indicated that there is a statistically significant difference between the two process means ( $p=0.0013$ ).
- The centralized, national process is faster (2.6 average days) than the local express reshipment process (4.6 average days).
- An additional survey conducted with focus groups indicated that the deposit mailing location is not a significant factor for a majority of respondents. As an aside, the original data indicating that customers were more comfortable mailing deposits within their state could not be found.
- A benchmarking analysis of direct competitors indicated that all utilized a centralized, national deposit process.

### **Project Conclusions**

It did not take further data collection to convince the leaders of the business to modify their deposit process and move to a centralized, national process. The facts spoke for themselves. Cost savings resulting from only printing one address envelopes (instead of numerous local), reduced overhead associated with processing, fewer customer inquiry calls and investigations, and a more stable process resulted in savings of \$4MM per year. Not bad for a six month Black Belt project.

## **7.5 STATISTICAL QUALITY CONTROL (SQC)**

The application of statistical techniques to measure and evaluate the quality of a product, service, or process is termed as SQC.

### **7.5.1 Two Basic Categories:**

#### **I. Statistical Process Control (SPC):**

- the application of statistical techniques to determine whether a process is functioning as desired

## II. Acceptance Sampling:

- the application of statistical techniques to determine whether a population of items should be accepted or rejected based on inspection of a sample of those items.

### 7.5.2 Quality Measurement: Attributes vs. Variables

#### Attributes:

Characteristics that are measured as either "acceptable" or "not acceptable", thus have only discrete, binary, or integer values.

#### Variables:

Characteristics that are measured on a continuous scale.

### 7.5.3 Statistical Process Control (SPC) Methods

Statistical process control (SPC) monitors specified quality characteristics of a product or service so as to detect whether the process has changed in a way that will affect product quality and

To measure the current quality of products or services

- Control is maintained through the use of control charts. The charts have upper and lower control limits and the process is in control if sample measurements are between the limits.
- Control chart for Attributes
  - P Charts** - measures proportion defective.
  - C Charts** - measures the number of defects/unit.
- Control chart for Variables
  - X bar and R charts are used together - control a process by ensuring that the sample average and range remain within limits for both.
- Basic Procedure
  1. An upper control limit (UCL) and a lower control limit (LCL) are set for the process.
  2. A random sample of the product or service is taken, and the specified quality characteristic is measured.
  3. If the average of the sample of the quality characteristic is higher than the upper control limit or lower than the lower control limit, the process is considered to be "out of control".

### 7.5.4 Control Charts For Attributes

#### p-Charts for Proportion Defective

p-chart: a statistical control chart that plots movement in the sample proportion defective (p) over time

#### Procedure:

1. take a random sample and inspect each item.
2. determine the sample proportion defective by dividing the number of defective items by the sample size.
3. plot the sample proportion defective on the control chart and compare with UCL and LCL to determine if process is out of control.

The underlying statistical sampling distribution is the binomial distribution, but can be approximated by the normal distribution with:

mean =  $\mu = np$  (**Note - add the bars above the means used in all the equations in this section**)

standard deviation of p:  $\sigma_{\hat{p}} = \text{square root of } (p(1-p) / n)$

where  $p$  = historical population **proportion defective** and  $n$  = sample size

**Control Limits:**

$$\text{UCL} = \bar{u} + z \sigma_p$$

$$\text{LCL} = \bar{u} - z \sigma_p$$

$z$  is the number of standard deviations from the mean. It is set based how certain you wish to be that when a limit is exceeded it is due to a change in the process proportion defective rather than due to sample variability. For example:

If  $z = 1$  if  $p$  has not changed you will still exceed the limits in 32% of the samples (68% confident that mean has changed if the limits are exceeded).

$z = 2$  - limits will be exceeded in 4.5 (95.5 % confidence that mean has changed)

$z = 3$  - limits will be exceeded in .03 (99.7% confidence)

**c-Charts for Number of Defects Per Unit**

c-chart: a statistical control chart that plots movement in the number of defects per unit.

**Procedure:**

1. randomly select one item and count the number of defects in that item
2. plot the number of defects on a control chart
3. compare with UCL and LCL to determine if process is out of control

The underlying sampling distribution is the Poisson distribution, but can be approximated by the normal distribution with:

$$\text{mean} = c$$

$$\text{standard deviation} = \text{square root of } c$$

where  $c$  is the historical average number of **defects/unit**

**Control Limits:**

$$\text{UCL} = c + z c$$

$$\text{LCL} = c - z c$$

**Control Charts for Variables**

Two charts are used together: **R-chart ("range chart")** and **X bar chart ("average chart")**

Both the process variability (measured by the R-chart) and the process average (measured by the X bar chart) must be in control before the process can be said to be in control.

Process variability must be in control before the X bar chart can be developed because a measure of process variability is required to determine the -chart control limits.

**R-Chart for Process Variability:**

$$\text{UCLR} = D_4(\bar{R})$$

$$\text{LCLR} = D_3(\bar{R})$$

where  $\bar{R}$  is the average of past  $R$  values, and  $D_3$  and  $D_4$  are constants based on the sample size

**Chart for Process Average:**

$$\text{UCLR} = \bar{X} + A_2(\bar{R})$$

$$\text{LCL} = \bar{X} - A_2(\bar{R})$$

where  $\bar{X}$  is the average of several past values, and  $A_2$  is a constant based on the sample size

### 7.5.5 Other Types of Attribute-Sampling Plans

#### Double-Sampling Plan

Specifies two sample sizes ( $n_1$  and  $n_2$ ) and two acceptance levels ( $c_1$  and  $c_2$ )

1. if the first sample passes (actual defects  $c_1$ ), the lot is accepted
2. if the first sample fails and actual defects  $> c_2$ , the lot is rejected
3. if first sample fails but  $c_1 < \text{actual defects} < c_2$ , the second sample is taken and judged on the combined number of defectives found.

#### Sequential-Sampling Plan

Each time an item is inspected, a decision is made whether to accept the lot, reject it, or continue sampling.

#### Acceptance Sampling

Goal: To accept or reject a batch of items. Frequently used to test incoming materials from suppliers or other parts of the organization prior to entry into the production process.

Used to determine whether to accept or reject a batch of products. Measures number of defects in a sample. Based on the number of defects in the sample the batch is either accepted or rejected. An acceptance level  $c$  is specified. If the number of defects in the sample is  $c$  the batch is accepted, otherwise it is rejected and subjected to 100% inspection.

- **Case Study**

#### Statistical Quality Control in the Packaging Industries - Case Study

Statistical Quality Control (SQC) is a necessary part of the production and use of modern packaging materials. The software chosen to satisfy basic SQC needs will determine whether it is an awkward, intrusive task or a smoothly operating part of the process. SQC software must not only collect quality data and produce control charts, but also provide the capabilities that make it the core of a well run and effective quality system.

The successful implementation of Statistical Quality Control (SQC) begins with the selection of the tools and methods best suited to the company's quality goals. Because manual charting can be burdensome and time-consuming, PC-based SQC using specialized software is preferable for routine charting and essential for process improvement studies. Numerous PC-based SQC software packages are readily available. Most, however, were developed for discrete manufacturing, particularly the automotive sector, and may not suit the diversified needs of modern packaging manufacturers and packaging users. When evaluating SQC software, packaging producers and manufacturers need to be aware of such shortcomings when making their selection.

## 7.6. STOCHASTIC FRONTIER ANALYSIS (SFA), FUZZY SETS THEORY (FST) & MALMQUIST INDEX (MI)

### 7.6.1 Stochastic Frontier Analysis (SFA)

A researcher wishes to estimate a production function or a cost function. The object is to estimate not the average production or average cost, but the maximum possible production given a set of inputs or the minimum possible cost of a set of outputs. OLS regression estimates the mean of the dependent variable conditional on the explanatory variables; Quantile regression is based on a quantile (e.g. 10th, 25th, median, 75th, 90th), not the maximum or minimum; The max or min cannot be detected directly and used to define the sample for selection bias analysis; Limited dependent variable models truncate the dependent variable into categories or limits but not the maximum or minimum.

None of those standard econometric models is the answer. The answer is frontier functions, econometric stochastic frontier analysis (SFA) or linear programming data envelopment analysis (DEA). Frontier



functions estimate maxima or minima of a dependent variable given explanatory variables, usually to estimate production or cost functions.

SFA has a stochastic frontier with a probability distribution. DEA has a non-stochastic frontier. SFA has one output, or an a priori weighted average of multiple outputs. DEA often has more than one output, no a priori weights, but assumes input-output separability. Both can have stochastic inefficiency, SFA always does, DEA sometimes does

### **Case Study**

#### **Measuring hospital efficiency using stochastic frontier analysis – a comparative analysis of hospitals**

##### **Background**

Measuring efficiency in health care presents analytical challenges including defining measurable outputs and the availability of information about inputs. International comparisons are particularly difficult given the lack of reliable and comparable data.

##### **Aims**

- (i) To identify differences in the production functions of hospitals in each country;
- (ii) To analyse which resources and hospital characteristics affect efficiency levels;
- (iii) To assess levels of technical efficiency in each country;
- (iv) To characterise and understand differences in efficiency levels between countries.

##### **Data**

Patient level data is available for all public hospitals in the participating countries, providing detailed information on patient characteristics and medical conditions, accounting for differences in case-mix. Data on hospital resources includes the number of employees, number of physicians, number of nurses, number of beds, teaching status of the hospital and other structural characteristics.

##### **Methods**

For efficiency measurement the number of discharges weighted for the complexity of patients treated in the hospital is used as a proxy for output. Variables relating to hospital resources are used to estimate the quantity of inputs. Stochastic frontier analysis with bootstrapping is used to estimate each country's production function and to analyse efficiency levels. Technical efficiency of each hospital in each country is then estimated enabling the characterisation of the reality during the period under analysis. Differences in efficiency levels between countries can therefore be assessed, by the estimation of the optimal level of resources in order to identify any excess resource use.

##### **Results**

Preliminary results are available which indicate that the number of beds is the most significant estimator for the hospital production function. The number of doctors and the number of employees are also significant in some years. The average efficiency level has been stable over the period analysed but the tails of the distribution are becoming more heavy over time, meaning less hospitals are near the median. The percentage of hospitals achieving levels of efficiency above 90% increased over time, particularly in 2008 and 2009, but the percentage of those achieving less than 20% of efficiency also rose. The presentation will include results from other countries in the ECHO consortium, permitting hospital level comparisons across countries.

The estimation and comparison of hospital technical efficiency over time provides valuable information on how to improve hospital management and performance. This can be done by identifying first how differently hospitals are producing and second by understanding how and which resources affect efficiency.

Traditionally, PA or efficiency measurement has been a major managerial concern in both the

manufacturing sector and the service industry. Consequently, a wide variety of methods are used to measure efficiency. One of the methods is Frontier approach, which evaluates efficiency against production functions. A production function defines the maximum levels of outputs attainable with a certain combination of inputs or the minimum possible level of inputs for certain level of outputs. The engineering based approach defines productivity by comparing the current performance to a suitable set of engineering standards (Sueyoshi 1992). In both these methods controversy arises when the analyst attempts to assign relative weights to factors. Thus, prior assumptions on weights have reservations, and this problem is eliminated in the use of DEA, as the weights are assigned voluntarily by the method.

### 7.6.2 Fuzzy Sets

**Fuzzy sets** are sets whose elements have degrees of membership. Fuzzy sets were introduced by Lotfi A. Zadeh and Dieter Klaua in 1965 as an extension of the classical notion of set. At the same time, Salii (1965) defined a more general kind of structures called L-relations, which were studied by him in an abstract algebraic context. Fuzzy relations, which are used now in different areas, such as linguistics (De Cock, et al, 2000), decision-making (Kuzmin, 1982) and clustering (Bezdek, 1978), are special cases of L-relations when L is the unit interval  $[0, 1]$ .

In classical set theory, the membership of elements in a set is assessed in binary terms according to a bivalent condition — an element either belongs or does not belong to the set. By contrast, fuzzy set theory permits the gradual assessment of the membership of elements in a set; this is described with the aid of a membership function valued in the real unit interval  $[0, 1]$ . Fuzzy sets generalize classical sets, since the indicator functions of classical sets are special cases of the membership functions of fuzzy sets, if the latter only take values 0 or 1. In fuzzy set theory, classical bivalent sets are usually called crisp sets. The fuzzy set theory can be used in a wide range of domains in which information is incomplete or imprecise, such as bioinformatics.

Fuzzy sets can be applied, for example, to the field of genealogical research. When an individual is searching in vital records such as birth records for possible ancestors, the researcher must contend with a number of issues that could be encapsulated in a membership function. Looking for an ancestor named John Henry Pittman, who you think was born in (probably eastern) Tennessee circa 1853 (based on statements of his age in later censuses, and a marriage record in Knoxville), what is the likelihood that a particular birth record for "John Pittman" is your John Pittman? What about a record in a different part of Tennessee for "J.H. Pittman" in 1851? (It has been suggested by Thayer Watkins that Zadeh's ethnicity is an example of a fuzzy set.)

### Fuzzy Sets in HR Management

This project specializes in the implementation of the Microsoft Dynamics NAV information system. The evaluation of employees is based on multiple criteria evaluations. The criteria are derived from typical competencies of the employees. A competency model has been created for any given role with different normalized weights assigned to various competencies. The evaluation proceeds in the following manner: Firstly, the appointed evaluators fill in a questionnaire indicating to what extent, in their view, the tested employee meets his/her competencies. These evaluations are expressed using fuzzy scales. Normalized weights assigned to the evaluators of any given employee are set based on the intensity of cooperation between the employee and his/her evaluators. The level of fulfillment of each competency by the given employee is calculated as a weighted average of the fuzzy evaluations, conducted by each of his/her evaluators. Then, the overall fulfillment level of the employee's working role, again as a weighted average of fuzzy numbers, is calculated according to a specified model. This produces an overall evaluation of the employee. The evaluation process is followed by an interview where the employee is informed of his/her evaluation results, the employees gaps are discussed, and possibilities for improvement are proposed.

### Case Study

Fuzzy Set Theory Approach for Measuring the Performance of Relationship-Based Construction Projects in Australia :

Research into performance measures for relationship-based construction projects becomes crucial because of an increasing trend of client organizations to adopt a relationship-based (or relational contracting) approach to their construction projects worldwide over the last decade. However, few, if any, comprehensive and systematic research studies focus on developing a comprehensive, objective, reliable, and practical performance evaluation model for relationship-based construction projects. A performance index (PI), which comprises eight weighted key performance indicators (KPIs) and a set of corresponding quantitative indicators (QIs) for measuring the performance of relationship-based construction projects have been developed in Australia. The PI and QIs can assist in developing a benchmark for measuring the performance of relationship-based construction projects. However, the establishment of a set of QIs cannot fully solve the subjectivity of performance evaluation. To remedy this deficiency, the aim of this paper is to adopt a fuzzy set theory (FST) approach to establish a well-defined range of quantitative requirements (QRs) for each QI within each of the five performance levels. By using the modified horizontal approach, fuzzy membership functions (FMFs) have been constructed through three various methods, namely constrained regression line with the vertical error method (VEM), the horizontal error method (HEM), and the bisector error method (BEM). It was shown that the results derived from the three methods were similar, and it seems that the BEM is the best technique to construct the FMFs because it considers both the errors created by the residual sum of squares by both vertical and horizontal distances. The newly developed performance evaluation model is not only innovative in nature, but it can also improve the objectiveness, reliability, and practicality in evaluating the performance of relationship-based construction projects.

#### 7.6.3 Malm Quist Index (MI)

The **Malmquist Index** (MI) is a bilateral index that can be used to compare the production technology of two economies. It is named after Professor Sten Malmquist, on whose ideas it is based. It is also called the Malmquist Productivity Index.

The MI is based on the concept of the Production function. This is a function of maximum possible production, with respect to a set of inputs pertaining to capital and labour. So, if  $S_a$  is the set of labour and capital inputs to the production function of Economy A, and  $Q_a$  is the production function of Economy A, we could write  $Q_a = f_a(S_a)$ .

While the production function would normally apply to an enterprise, it is possible to calculate it for an entire region or nation. This would be called the aggregate production function.

To calculate the Malmquist Index of economy A with respect to economy B, we must substitute the labour and capital inputs of economy A into the production function of B, and vice versa. The formula for MI is given below.

$$MI = \sqrt{(Q_1 Q_2) / (Q_3 Q_4)}$$

where

$$Q_1 = f_a(S_a)$$

$$Q_2 = f_a(S_b)$$

$$Q_3 = f_b(S_a)$$

$$Q_4 = f_b(S_b)$$



Note that the MI of A with respect to B is the reciprocal of the MI of B with respect to A. If the MI of A with respect to B is greater than 1, the aggregate production technology of economy A is superior to that of economy B.

### Case Study

Indian IT and ICT industry: A performance analysis using data envelopment analysis and Malmquist index

The present study gives an account of IT and ICT infrastructure in India and points out the reasons for the boom in the IT exports and outsourcing business today and in times to come. The article analyzes the performances of the Indian IT industry by working out the technical efficiency of the software and telecommunication firms using the mathematical model of the Data Envelopment Analysis (DEA). The DEA is a non linear programming way of calculating technical efficiency of the decision making units. The study also examines the impact of various determinants on technical efficiency of software firms and net exports across the IT firms and further examines the determinants for new technology adoption by telecommunication industries, because the success of the software firms in terms of its exports is intertwined with the performance of telecommunication industry. The study uses a Malmquist index to estimate total factor productivity (TFP) change for the common set of software firms existing between 1996 and 2006 using a prowess data base. The total factor productivity is decomposed into efficiency change (catching up phenomena) and technical change (innovations) for the common set of software firms existing between 1996 and 2006 in India. At the end the study works out the performance of the Indian ICT sector in comparison with countries which are front runners using the DEA and global information technology report 2006 data base. The study will quantify the changes needed in the relatively good Indian ICT environment and ICT readiness to increase its ICT usage among individuals, business and government. The article confirms the improvements in productivity, efficiency, and technical change of the Indian Software industry from 1996 to 2006.

## 7.7 PRINCIPAL COMPONENT ANALYSIS (PCA)

When measuring only two variables, such as height and weight in a dozen patients, it is easy to plot this data and to visually assess the correlation between these two factors. However, in a typical microarray experiment, the expression of thousands of genes is measured across many conditions such as treatments or time points. Therefore, it becomes impossible to make a visual inspection of the relationship between genes or conditions in such a multi-dimensional matrix. One way to make sense of this data is to reduce its dimensionality. Several data decomposition techniques are available for this purpose: Principal Components Analysis (PCA) is among these techniques that reduces the data into two dimensions.

### 7.7.1 Principal Components Analysis

Principal Components Analysis is a method that reduces data dimensionality by performing a covariance analysis between factors. As such, it is suitable for data sets in multiple dimensions, such as a large experiment in gene expression. Let's take an example that illustrates how PCA works with a microarray experiment: Say that you measure 10,000 genes in 8 different patients. These values could form a matrix of 8 x 10,000 measurements. Now imagine that each of these 10,000 genes is plotted in a multi-dimensional on a scatter plot consisting of 8 axes, 1 for each patient. The result is a cloud of values in multi-dimensional space. To characterize the trends exhibited by this data, PCA extracts directions where the cloud is more extended. For instance, if the cloud is shaped like a football, the main direction of the data would be a midline or axis along the length of the football. This is called the first component, or the principal component. PCA will then look for the next direction, orthogonal to the first one, reducing the multidimensional cloud into a two-dimensional space.

### 7.7.2 Some Insights

- Because it is hard to visualize multi-dimensional space, principal components analysis (PCA), a

popular multivariate technique, is mainly used to reduce the dimensionality of  $p$  multi-attributes to two or three dimensions.

- PCA summarizes the variation in a correlated multi-attribute to a set of uncorrelated components, each of which is a particular linear combination of the original variables.
- The extracted uncorrelated components are called principal components (PC) and are estimated from the eigenvectors of the covariance or correlation matrix of the original variables.
- Therefore, the objective of PCA is to achieve parsimony and reduce dimensionality by extracting the smallest number components that account for most of the variation in the original multivariate data and to summarize the data with little loss of information.

In PCA, uncorrelated PC's are extracted by linear transformations of the original variables so that the first few PC's contain most of the variations in the original dataset.

- These PCs are extracted in decreasing order of importance so that the first PC accounts for as much of the variation as possible and each successive component accounts for a little less.
- Following PCA, analyst tries to interpret the first few principal components in terms of the original variables, and thereby have a greater understanding of the data.
- To reproduce the total system variability of the original  $p$  variables, we need all  $p$  PCs. However, if the first few PCs account for a large proportion of the variability (80-90%), we have achieved our objective of dimension reduction.
- Because the first principal component accounts for the co-variation shared by all attributes, this may be a better estimate than simple or weighted averages of the original variables. Thus, PCA can be useful when there is a severe high-degree of correlation present in the multi-attributes
- In deriving PC, the correlation matrix is commonly used when different variables in the dataset are measured using different units (annual income, educational level, numbers of cars owned per family) or if different variables have different variances. Using the correlation matrix is equivalent to standardizing the variables to zero mean and unit standard deviation.

### 7.7.3 PCA Terminology

- **Eigenvalues** measure the amount of the variation explained by each PC and will be largest for the first PC and smaller for the subsequent PCs.
- An eigenvalue greater than 1 indicates that PCs account for more variance than accounted by one of the original variables in standardized data. This is commonly used as a cutoff point for which PCs are retained.
- **Eigenvectors** provides the weights to compute the uncorrelated PC, which are the linear combination of the centered standardized or centered un-standardized original variables.

### Case Study

Uganda has witnessed persistent poor employee performance in public organizations since mid 60s, which scholars attribute to the 1966/67 crisis and the political turmoil of the early 70s up to mid 80s. Despite government's effort to avert the crisis by introducing reforms to improve employee performance, the situation has not improved. The study's main objective was to investigate whether there is a relationship between performance management practices (decision rights, incentives, performance contracts, organization resources and performance measurement) and employee performance in public organizations in Uganda.

The study was conducted at Kampala City Council and the Ministry of Education and Sports. Data was collected from a stratified random sample of 517 participants and from a purposively selected sample

of 32 respondents. A 5- point Likert scale questionnaire and three interview guides were used to collect data. The Principal component analysis was used to establish the number of major components which accounted for most of the variance within the performance management practices, government policy and employee performance, The Mann-Whitney test was used to establish the mean difference between the two organizations. Pearson chi-square test was used to establish the relationship between the performance management practices and employee performance.

Log-Linear analysis was used to establish the interactive effect among the performance management practices, government policy and employee performance. Qualitative data was analyzed using pragmatic content analysis. The results of the study revealed that the selected performance management practices explained 54% of employee performance while 46% was explained by other factors. Findings also indicated that the Ministry of Education and Sports had better performance management practices than Kampala City Council.

The study findings also established that performance management practices had a significant positive relationship with employee performance apart from incentives that had an inverse relationship with employee performance. Findings also revealed that there was a 3-way order interactive effect among performance management practices. Performance measurement, government policy and employee performance had the most critical interaction effect. On the basis of the findings, it was recommended that public organization managers and policy makers must ensure that the performance measurement tool used in public organizations is modernized to spell out what it really intends to measure. Measurement should be a continuous process with immediate feedback given to employees.

The performance gaps must be addressed in line with government policy. Secondly, public sector managers must ensure that the incentive systems in place are modernized by making them more attractive so as to induce employees to perform optimally. Managers must exercise procedural and distributive justice in the administration of the rewards. They should also ensure that decisions are decentralized to allow full employee participation in the decision making processes. Lastly public sector managers must see to it that organization.

## 7.8 TOTAL PRODUCTIVITY MANAGEMENT (TPM)

Total Productive Management (TPM) provides a system for coordinating all the various improvement activities for the company so that they contribute to the achievement of corporate objective. Starting with a corporate vision and broad goals, these activities are developed into supporting objectives, or targets, throughout the organisation. The targets are specifically and quantitatively defined. This seminar therefore emphasizes how to improve the competitiveness of products and services in quality, price, cost and customer responsiveness, thereby increasing the profitability, market share, and return on investment in human, material, capital, and technology resources.

### 7.8.1 Total Productive Maintenance (TPM)

Originated in Japan in 1971 as a method for improved machine availability through better utilization of maintenance and production resources.

Whereas in most production settings the operator is not viewed as a member of the maintenance team, in TPM the machine operator is trained to perform many of the day-to-day tasks of simple maintenance and fault-finding. Teams are created that include a technical expert (often an engineer or maintenance technician) as well as operators. In this setting the operators are enabled to understand the machinery and identify potential problems, righting them before they can impact production and by so doing, decrease downtime and reduce costs of production.

TPM is a critical adjunct to lean manufacturing. If machine uptime is not predictable and if process capability is not sustained, the process must keep extra stocks to buffer against this uncertainty and flow through the process will be interrupted. Unreliable uptime is caused by breakdowns or badly performed maintenance. Correct maintenance will allow uptime to improve and speed production

through a given area allowing a machine to run at its designed capacity of production.

One way to think of TPM is “deterioration prevention”: deterioration is what happens naturally to anything that is not “taken care of”. For this reason many people refer to TPM as “total productive manufacturing” or “total process management”. TPM is a proactive approach that essentially aims to identify issues as soon as possible and plan to prevent any issues before occurrence. One motto is “zero error, zero work-related accident, and zero loss

TPM is a management process developed for improving productivity by making processes more reliable and less wasteful. TPM is an extension of TQM (Total Quality Management). The objective of TPM is to maintain the plant or equipment in good condition without interfering with the daily process. To achieve this objective, preventive and predictive maintenance is required. By following the philosophy of TPM we can minimize the unexpected failure of the equipment.

To implement TPM the production unit and maintenance unit should work jointly.

Original goal of total productive management:

“Continuously improve all operational conditions, within a production system; by stimulating the daily awareness of all employees” (by Seiichi Nakajima, Japan, JIPM)

TPM focuses primarily on manufacturing (although its benefits are applicable to virtually any “process”) and is the first methodology Toyota used to improve its global position (1950s). After TPM, the focus was stretched, and also suppliers and customers were involved (Supply Chain), this next methodology was called lean manufacturing. This sheet gives an overview of TPM in its original form.

An accurate and practical implementation of TPM, will increase productivity within the total organization, where:

- (i) a clear business culture is designed to continuously improve the efficiency of the total production system
- (ii) a standardized and systematic approach is used, where all losses are prevented and/or known.
- (iii) all departments, influencing productivity, will be involved to move from a reactive- to a predictive mindset.
- (iv) a transparent multidisciplinary organization in reaching zero losses.
- (v) steps are taken as a journey, not as a quick menu.

Finally TPM will provide practical and transparent ingredients to reach operational excellence.

### **7.8.2 Goals**

TPM has basically 3 goals - Zero Product Defects, Zero Equipment Unplanned Failures and Zero Accidents. It sets out to achieve these goals by Gap Analysis of previous historical records of Product Defects, Equipment Failures and Accidents. Then through a clear understanding of this Gap Analysis (Fishbone Cause-Effect Analysis, Why-Why Cause-Effect Analysis, and P-M Analysis) plan a physical investigation to discover new latent fuguai (slight deterioration) during the first step in TPM Autonomous Maintenance called “Initial Cleaning”.

Many companies struggle to implement TPM due to 2 main reasons. First is having insufficient knowledge and skills especially in understanding the linkages between the 8 Pillar-Activities in TPM.[1] It does not help in that most TPM books are long on the theories but scanty on the implementation details. The second reason is that TPM requires more time, resources and efforts than most of these companies believe they can afford. A typical TPM implementation requires company-wide participation and full results can only be seen after 3 years and sometimes 5 years. The main reason for this long duration is due to the basic involvement and training required for Autonomous Maintenance participation where operators participate in the restoring the equipment to its original capability and condition and then improving the equipment.



An effective Fast-Track TPM Implementation Approach has been successful in a Paper Mill and Electronics Industries and documented. It circumvented this problem by assigning Project Teams to do Autonomous Maintenance for the AM Steps of 1) Initial Cleaning and 2) Eliminating Sources of Contamination and Improving Equipment Accessibility. Production Operators take over the Autonomous Maintenance after the AM Step 3 (Initial Maintenance Standards) has been established. This has been proven to reduce TPM implementation time by about 50%.

TPM success measurement - A set of performance metrics which is considered to fit well in a lean manufacturing/TPM environment is overall equipment effectiveness, or OEE. For advanced TPM world class practitioners, the OEE cannot be converted to costs using Target Costing Management (TCM) OEE measurements are used as a guide to the potential improvement that can be made to an equipment, and by identifying which of the 6 losses is the greater, then the techniques applicable to that type of loss. Consistent application of the applicable improvement techniques to the sources of major losses will positively impact the performance of that equipment.

Using a criticality analysis across the factory should identify which equipments should be improved first, also to gain the quickest overall factory performance.

The use of Cost Deployment is quite rare, but can be very useful in identifying the priority for selective TPM deployment.

### **7.8.3 Steps to Start TPM**

The Steps are –

- Identify the key people
- Management should learn the philosophy.
- Management must promote the philosophy.
- Training for all the employees.
- Identify the areas where improvement are needed.
- Make an implementation plan.
- Form an autonomous group.

### **7.8.4 Benefits**

With the adoption of TPM at the enterprise level, your organisation would benefit from the following aspect:

- A set of new management goals will be developed by the Management, using the skills and training provided during the implementation of the TPM
- Team bonding and better accountability
- Improved quality and total cost competitiveness
- Productivity and quality team training for problem solving
- Earlier detection of factors critical to maintaining equipment “uptime”
- Measure impact of defects, sub-optimal performance, and downtime using OEE (Overall Equipment Effectiveness)
- Motivated people function better all the time

### **Case Study**

#### **Resource Use, Waste, and Total Productivity Management in Saudi Arabia Hotel Industry**

The costs of resources and impacts of waste could obviously affect the revenue, public image and environmental performance of the hotels sector. The hotel industry in Saudi Arabia is expanding quickly with increasing international arrivals and domestic tourist. Management of the hotel industry's resources



would contribute to the long term sustainability of the tourism sector. There has been no systematic study on resources use and its analysis in Saudi Arabia. Therefore, there is a need for conducting a study to assess the resource use and management in the hotels sector in Saudi Arabia. This study was conducted through the distribution of a questionnaire to 80 hotels on waste generation, and energy and water consumption. These results are compared with those in other countries. Benchmarks for efficient use of resources in the hotels sector in Saudi Arabia are presented in this paper. In addition, accomplishing increased productivity remains an important matter with many service firms. Therefore, in the second part of this paper the objective is to gain insights as to how managers can improve the productivity of their hotel industry. This was implemented by applying the concept of Total Productivity Management to a real case study. The results of this paper can be used as a guideline for all hotels in Saudi Arabia for the efficient use and management of resources and to know how to apply the concept of the Total Productivity Management in order to achieve the management goals.

- **Productivity of the tourism sector**

Tourism related industries in developed countries are not only facing global competition but also competing in factor markets with other sectors with higher productivity. Tourism as a service and a self-service industry, which suffers comparatively low productivity, should increase its productivity, and its related industries must increase their competitiveness in the market.

Tourism industries are labour-intensive, so the magnitude of the differences in wage levels between developed and developing countries plays a significant role. Developed countries' tourism faces high wages and hard currency while earning more per visitor and achieving higher added value per employee. The ratio of value added to GDP in the tourism sectors of industrialized nations is in a downward spiral. In fact, the research found that a country's level of development has a considerable influence on tourism growth. The strongest tourism growth in recent years actually appear in the largest emerging economies, even though the developments in world tourism has led to dynamic and lasting growth in all countries. Developing countries' tourism-related industries have a competitive advantage because of the countries' plentiful resources to offer and lower cost on producing the services. As a matter of fact, tourism is the most productive sector in developing countries, compared with the rest of the economy (Todd, 2008).

#### **Measurement problems in the tourism sector**

As a part of the service sector, the measurement problems exist in the tourism sector as well. Some scholars believe the measurement problems play a role in the low productivity within the industry because without accurately measuring the productivity it is hard to manage and monitor the production procedures well. There are three difficulties in measuring productivity: identification of the appropriate inputs and outputs; appropriate measures of those inputs and outputs; the appropriate ways of measuring the relationship between inputs and outputs (Anderson, 1996). The intangible service nature, simultaneous production and consumption of the hospitality and the perishability and heterogeneity of services cause those difficulties. The inputs of tourism-dependent industries can be defined in terms of units of human resources, capital and natural resources required for the provision of a service. As a result, the value of a tourism service is measured by the price that can be charged, which depends both on efficient marketing in tourism markets and the efficient application of the factors of production.

#### **Improving productivity of the tourism sector**

Tourism is the sector in which the manufactured experience requires high quality levels. The quality of the experience is the base of productivity in tourism, which is reflected in the subjectively perceived satisfaction of the visitor. Also, the quality of the services is the basic element to compete between destinations. As a result, anything that contributes to the efficient production and marketing of quality experiences helps to improve productivity in tourism. To improve productivity, it needs not only to produce efficiently but also sell the products efficiently to the markets.

The dual structure of the tourism related industries, as shown in Table, determines the existence of two types of corporate organizations in the tourism sector, small-to-medium-sized enterprises (SMEs) and large companies. SMEs can tailor and personalize its services to the needs of the individual visitor and rapidly adapt the changing market requirement but such personalized tourism is very expensive. In fact, the competition on price and cutting cost have become more and more important for succeeding in the tourism industry, which means improving productivity. The big corporations are able to massively provide standardized products which allow them to cut the cost and adapt a lower price.

**Table : Dual structure of the tourism related industries**

Characteristics	Tourism Sector (outgoing)	Destination oriented SME's (in-coming)
Functions	Organization, Information, Transport	Welcome, Hospitality, Leisure
Related industries	Travel agency, Airline industry, Other	Accommodation, Catering, Cable cars, other
Corporate Organization	Large companies	SMEs

## 7.9 SUPPLY CHAIN MANAGEMENT (SCM)

The concept of Supply Chain Management is based on two core ideas. The first is that practically every product that reaches an end user represents the cumulative effort of multiple organizations. These organizations are referred to collectively as the supply chain.

The second idea is that while supply chains have existed for a long time, most organizations have only paid attention to what was happening within their "four walls." Few businesses understood, much less managed, the entire chain of activities that ultimately delivered products to the final customer. The result was disjointed and often ineffective supply chains.

Supply chain management, then, is the active management of supply chain activities to maximize customer value and achieve a sustainable competitive advantage. It represents a conscious effort by the supply chain firms to develop and run supply chains in the most effective & efficient ways possible. Supply chain activities cover everything from product development, sourcing, production, and logistics, as well as the information systems needed to coordinate these activities.

The organizations that make up the supply chain are "linked" together through physical flows and information flows. Physical flows involve the transformation, movement, and storage of goods and materials. They are the most visible piece of the supply chain. But just as important are information flows. Information flows allow the various supply chain partners to coordinate their long-term plans, and to control the day-to-day flow of goods and material up and down the supply chain.

### 7.9.1 Terms & Definitions of Supply Chain Management

#### 1. Activity-Based Cost Accounting (ABC)

A cost accounting system that accumulates costs based on activities performed and then uses cost drivers to allocate these costs to products or other bases, such as customers, markets, or projects. It is an attempt to allocate overhead costs on a more realistic basis than direct labor or machine hours.

#### 2. Activity-Based Management (ABM)

The use of activity-based costing information about cost pools and drivers, activity analysis, and business processes to identify business strategies; improve product design, manufacturing, and distribution; and remove waste from operations.

### **3. Agreements**

An agreement should clearly state what you are buying and its cost. Delivery terms and responsibility, installation related issues, if applicable, an acceptance provision detailing how and when the buyer will accept the products, warranty issues, and your remedial actions should be clearly spelled out in the agreement. Arbitration and conflict resolution mechanisms should also be included in the contract because even the best written agreements are subject to misinterpretation. A well-developed agreement can provide adequate protection against economic opportunism between parties and lead to a positive relationship. Effective long-term agreements generally have specific, measurable objectives stated in them, including pricing mechanisms, delivery and quality standards and improvements, cost savings sharing, evergreen clauses, and termination of the relationship.

### **4. Business-to-Business Commerce (B2B)**

Business being conducted over the Internet between businesses. The implication is that this connectivity will cause businesses to transform themselves via supply chain management to become virtual organizations, reducing costs, improving quality, reducing delivery lead time, and improving due-date performance.

### **5. Capacity Management**

The function of establishing, measuring, monitoring, and adjusting limits or levels of capacity in order to execute all manufacturing schedules; i.e., the production plan, master production schedule, material requirements plan, and dispatch list. Capacity management is executed at four levels: resource requirements planning, rough-cut capacity planning, capacity requirements planning, and input/output control.

### **6. Capacity Planning**

The process of determining the amount of capacity required to produce in the future. This process may be performed at an aggregate or product-line level (resource requirements planning), at the master-scheduling level (rough-cut capacity planning), and at the material requirements planning level (capacity requirements planning).

### **7. Capacity Requirements Planning**

This is defined as the function of establishing, measuring, and adjusting limits or levels of capacity. The term capacity requirements planning in this context refers to the process of determining in detail the amount of labor and machine resources required to accomplish the tasks of production. Open shop orders and planned orders in the MRP system are input to CRP, which through the use of parts routings and time standards translates these orders into hours of work by work center by time period. Even though rough-cut capacity planning may indicate that sufficient capacity exists to execute the MPS, CRP may show that capacity is insufficient during specific time periods.

### **8. Capacity Strategy**

This is one of the strategic choices that a firm must make as part of its manufacturing strategy. There are three commonly recognized capacity strategies: lead, lag, and tracking. A lead capacity strategy adds capacity in anticipation of increasing demand. A lag strategy does not add capacity until the firm is operating at or beyond full capacity. A tracking strategy adds capacity in small amounts to attempt to respond to changing demand in the marketplace.

### **9. Capacity Utilization**

This is a measure (usually expressed as a percentage) of how intensively a resource is being used to produce a good or service. Utilization compares actual time used to available time. Traditionally, utilization is the ratio of direct time charged (run time plus setup time) to the clock time available.



Utilization is a percentage between 0% and 100% that is equal to 100% minus the percentage of time lost due to machine, tool, worker, etc., unavailability.

#### **10. Capacity – Information Flows**

Capacity is the capability of a worker, machine, work center, plant, or organization to produce output per time period. Information aids us in addressing capacity availability, unused capacity and performance issues that impact a business's revenue and productivity as well as its image and reputation.

#### **11. Capacity – Physical Flows**

- (i) The capability of a system to perform its expected function.
- (ii) The capability of a worker, machine, work center, plant, or organization to produce output per time period. Capacity required represents the system capability needed to make a given product mix (assuming technology, product specification, etc.). As a planning function, both capacity available and capacity required can be measured in the short term (capacity requirements plan), intermediate term (rough-cut capacity plan), and long term (resource requirements plan).

#### **12. Channel management**

The management of firms or individuals that participate in the flow of goods and services from the raw material supplier and producer to the final user or customer.

#### **13. Collaboration**

Collaboration is defined as the process by which partners adopt a high level of purposeful cooperation to maintain a trading relationship over time. The relationship is bilateral; both parties have the power to shape its nature and future direction over time. Mutual commitment to the future and a balanced power relationship are essential to the process. While collaborative relationships are not devoid of conflict, they include mechanisms for managing conflict built into the relationship.

#### **14. Commodity Strategy Development**

The purchasing plan for a family of items. This would include the plan to manage the supplier base and solve problems

#### **15. Continuous Improvement**

A never-ending effort to expose and eliminate root causes of problems; small step improvement as opposed to big step improvement.

#### **16. Contract**

An agreement between two or more competent persons or companies to perform or not to perform specific acts or services or to deliver merchandise. A contract may be oral or written. A purchase agreement when accepted by a supplier, becomes a contract. Acceptance may be in writing or by performance, unless the purchase order requires acceptance in writing.

#### **17. Contract Management**

Contract management is a strategic management discipline employed by both buyers and sellers whose objectives are to manage customer and supplier expectations and relationships, control risk and cost, and contribute to organizational profitability/success. For successful service contract administration, the buyer needs to have a realistic degree of control over the supplier's performance. Crucial to success in this area is the timely availability of accurate data including the contractor's plan of performance and the contractor's actual progress.

## 18. Cost Management

In terms of activity-based cost accounting, cost management involves control of activities to eliminate waste, improve cost drivers, and plan operations. This process should influence the organization's strategy setting process. Factors such as product pricing, introduction of new products, and distribution of existing products are examples of strategic decisions that are affected by cost management.

## 19. Cost System Design

An intelligent cost system design is one that is simple while still providing managers with information they need to make decisions. As most manufacturing processes were labor intensive at the turn of the century, a majority of cost management systems relied on direct labor to assign indirect costs to products and services. Indirect or overhead costs are costs that are associated with or caused by two or more operating activities jointly but are not traceable to each of them individually. Direct costs, on the other hand, are specifically traceable to or caused by a specific project or production operation.

The emergence of highly automated machines, which replaced direct labor with support labor, reduced the accuracy of direct labor as an estimator of indirect costs. This reduction first led to the emergence of machine hour-based cost systems. But both, labor based and machine hour based cost systems, rely on unit-level cost drivers and can provide adequate insights to managers about the costs of their products only in very simple manufacturing systems. As competition faced by firms increased, profit levels began to fall, and it became more important for the firm's cost system to report accurate product costs. More accurate products costs enable firms to fine tune its product mix so it is inherently more profitable. Activity based costing or management is a tool that more accurately identifies and allocates indirect costs to the products they support because it identifies the drivers of the indirect costs. This identification allows management to identify and implement cost savings opportunities.

## 20. Currency Conversions

Issues with currency conversion add complexity to the global sourcing process. The absence of fixed exchange rates can be a problem. Fluctuations in exchange rates can have a significant impact on the costs and profits made by the buyer and the seller. U.S. purchasing departments are particularly at a disadvantage. Their unfamiliarity in dealing with foreign currencies leads to higher costs in two ways: 1) the buyers attempt to put all currency risk on the supplier which causes the supplier to include charges for hedging; 2) In an attempt to avoid dealing with foreign currency, buyers' use U.S. subsidiaries who accept U.S. dollars but charge higher markups. The unfamiliarity of vendors and suppliers with currency conversion issues can cause supply chain slowdowns and force businesses to revert to using paper invoices, bound ledgers and filing cabinets leading to delays and increased costs in the supply chain.

## 21. Customer Relationship Management (CRM)

A marketing philosophy based on putting the customer first. It involves the collection and analysis of information designed for sales and marketing decision support to understand and support existing and potential customer needs. It includes account management, catalog and order entry, payment processing, credits and adjustments, and other functions.

## 22. Customer Value

The customer value approach focuses on how people choose among competing suppliers, customer attraction and retention, and market-share gains.

By highlighting the best performer on each key buying factor, marketers obtain a market derived, empirical aggregate of each supplier's customer value proposition. Often the view from the marketplace differs from the organization's internally developed customer value proposition.



### **23. Customer/Order Fulfillment Process**

A series of customers' interactions with an organization through the order filling process, including product/service design, production and delivery, and order status reporting.

### **24. Demand Management**

The function of recognizing all demands for goods and services to support the market place. It involves prioritizing demand when supply is lacking. Proper demand management facilitates the planning and use of resources for profitable business results.

### **25. Distribution Channel Design**

The planned channels of inventory disbursement from one or more sources to field warehouses and ultimately to the customer. There are several levels in the distribution network structure.

### **26. Facility Location**

Location decisions are a basic determinant of profitability in international logistics. Decisions on where to manufacture, to assemble, to store, to transship and to consolidate can make the difference between profit and loss. Because of international differences in basic factor costs and because of exchange rate movements, location decisions are very important. Also, these decisions involve substantial involvement in fixed assets in the form of facilities and equipment. Location decisions, therefore, can have a continuing impact over time on the company's financial and competitive position. As movement towards global manufacturing increases, organizations should consider location decisions through total cost analysis which includes activity related costs such as manufacturing, transportation and handling as well as inventory holding costs, tariffs, and taxes.

### **27. Forecast Error**

The difference between actual demand and forecast demand, stated as an absolute value or as a percentage. E.g., average forecast error, forecast accuracy, mean absolute deviation, tracking signal. There are three ways to accommodate forecasting errors: One is to try to reduce the error through better forecasting. The second is to build more visibility and flexibility into the supply chain. And the third is to reduce the lead time over which forecasts are required.

### **28. Forecast Sharing**

A supply partnership between a buyer and supplier is based on mutual interdependency and respect and calls for information sharing between the involved parties. By sharing its demand forecast with the supplier, the buyer benefits in two ways:

- 1) the partner becomes familiar with the buyer's needs, and
- 2) the buyer develops a dependable supply source. Forecast sharing allows the supplier to plan for and schedule production efficiently.

### **29. Forecasting**

The business function that attempts to predict sales and use of products so they can be purchased or manufactured in appropriate quantities in advance.

### 30. Forecasting Techniques

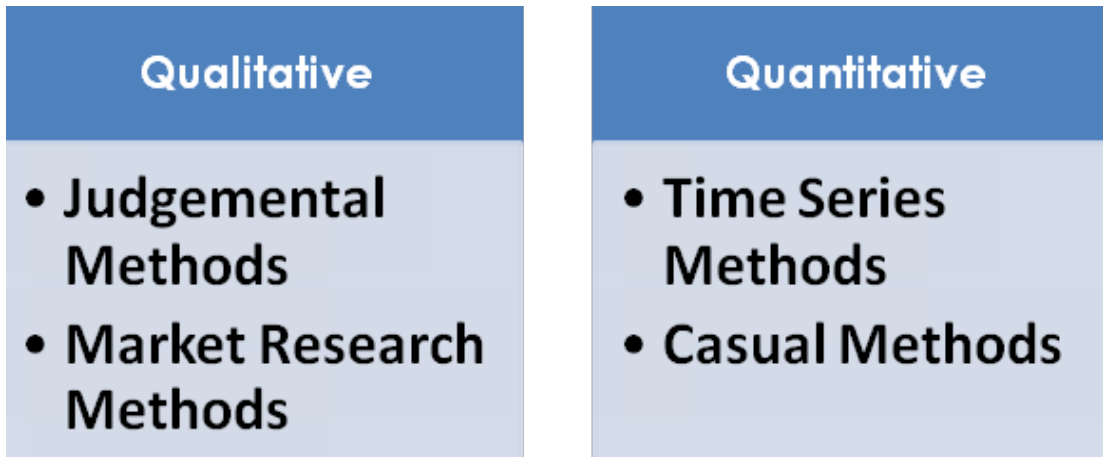

- **Judgmental Methods:**
  - ✓ Sales-force composite
  - ✓ Panels of experts
  - ✓ Delphi method
- **Market Research Methods:**
  - ✓ Markey testing
  - ✓ Market survey
- **Time Series Methods:**
  - ✓ Moving average
  - ✓ Exponential smoothing
  - ✓ Trend analysis
  - ✓ Seasonality
    - Use de-seasonalized data for forecast
    - Forecast de-seasonalized demand
    - Develop seasonal forecast by applying seasonal index to base forecast
- **Casual Methods:**
  - ✓ Single Regression analysis
  - ✓ Multiple Regression analysis

### 31. Inbound Logistics

Following the receipt of materials, parts or resale products from external suppliers, the subsequent storage, handling, and transportation requirements to facilitate either manufacturing or market distribution constitute inbound logistics.

### 32. Industry Standards

An industrial standard is a uniform identification that is agreed on. Industrial standardization can be defined as the process of establishing agreement on uniform identifications for definite characteristics of quality, design, performance, quantity, service, etc.



### **33. Information Sharing**

A strategic partnering relationship between suppliers and buyers is characterized by a willingness to be open, and to share forecasted demand and cost data as well as the benefits resulting from the information sharing. Both parties in the relationship generally follow a continuous improvement philosophy towards total cost of material acquisition and ownership along with quality and service. Cost, quality and schedule information that is confidential is shared both ways between firms during the early and ongoing stages of design and during the production life-cycle of the supplying relationship. This openness exists because of the high degree of trust earned through multiple successful interactions between the two organizations.

### **34. Information Technology**

The technology of computers, telecommunications, and other devices that integrate data, equipment, personnel, and problem-solving methods in planning and controlling business activities. Information technology provides the means for collecting, storing, encoding, processing, analyzing, transmitting, receiving, and printing text, audio, or video information.

Hardware: In the context of information technology, the computer and its peripherals constitute the hardware.

Software: The programs and documentation necessary to make use of a computer constitute the software.

### **35. Insource vs Outsource**

The act of deciding whether to produce an item internally or buy it from an outside supplier. Factors to consider in the decision include costs, capacity availability, proprietary and/or specialized knowledge, quality considerations, skill requirements, volume, and timing.

### **36. Interplant Transfer**

The shipment of a part or product by one plant to another plant or division within the corporation.

### **37. Inventory**

- 1) Those stocks or items used to support production (raw materials and work-in-process items), supporting activities (maintenance, repair, and operating supplies), and customer service (finished goods and spare parts). Demand for inventory may be dependent or independent. Inventory functions are anticipation, hedge, cycle (lot size), fluctuation (safety, buffer, or reserve), transportation (pipeline), and service parts.
- 2) In the theory of constraints, inventory is defined as those items purchased for resale and includes finished goods, work in process, and raw materials. Inventory is always valued at purchase price and includes no value-added costs, as opposed to the traditional cost accounting practice of adding direct labor and allocating overhead as work in process progresses through the production process.

### **38. Inventory Management Systems**

Software applications that permit monitoring events across a supply chain. These systems track and trace inventory globally on a line-item level and notify the user of significant deviations from plans. Companies are provided with realistic estimates of when material will arrive. With Inventory visibility, organizations are able to make decisions that optimize supply chain performance. Information is available to reduce costs by removing inventory from the supply chain, reducing obsolescence, decreasing operational assets, lowering network operations cost, and decreasing transportation costs. Visibility also increases competitiveness by improving customer satisfaction and market responsiveness.



### **39. Inventory Positioning**

Inventory positioning refers to the selective location of various items in the product line in plant, regional, or field warehouses. Inventory positioning has a bearing on facility location decision, and therefore, must be considered in the logistics strategy.

### **40. Joint Venture**

An agreement between two or more firms to risk equity capital to attempt a specific business objective.

### **41. Language**

Differences in culture, language, dialects or terminology may result in miscommunication and cause problems. While both parties may think that they understand what the other party has said, a true agreement may be missing. A simple word like "plant" for instance, can be a source of confusion – in the Far East, the word "plant" is interpreted to mean only a living organism, not a physical facility.

### **42. Lead Times/Cycle Times**

1) A span of time required to perform a process (or series of operations). 2) In a logistics context, the time between recognition of the need for an order and the receipt of goods. Individual components of lead time can include order preparation time, queue time, processing time, move or transportation time, and receiving and inspection time.

### **43. Lean Manufacturing**

A philosophy of production that emphasizes the minimization of the amount of all the resources (including time) used in the various activities of the enterprise. It involves identifying and eliminating non-value-adding activities in design, production, supply chain management, and dealing with the customers. Lean producers employ teams of multiskilled workers at all levels of the organization and use highly flexible, increasingly automated machines to produce volumes of products in potentially enormous variety. It contains a set of principles and practices to reduce cost through the relentless removal of waste and through the simplification of all manufacturing and support processes.

### **44. Legal Issues**

Purchasing law has been primarily developed from laws regarding contracts. In order for a contract to be valid, four conditions must be present: 1) Parties with full contractual capacity should willfully and in the absence of fraudulent activity have signed the contract; 2) the underlying purpose for the agreement must be legal; 3) all conditions regarding the offer and acceptance of the contract must be met; 4) the contract should have an element of mutual obligation; that is both parties must agree to do something they otherwise would not be required to do.

### **45. Logistics Information Systems**

Converting data to information, portraying it in a manner useful for decision making, and interfacing the information with decision-assisting methods are considered to be at the heart of an information system. Logistics information systems are a subset of the firm's total information system, and it is directed to the particular problems of logistics decision making. There are three distinct elements that make up this system: the input, the database and its associated manipulations, and the output. The inputs are data items needed for planning and operating logistics system obtained from sources like customers, company records, and published data and company personnel. Management of the database involves selection of the data to be stored and retrieved, choice of the methods of analysis and choice of the basic data-processing procedures..



#### **46. Logistics Management**

Logistics management is the process of strategically managing the procurement, movement and storage of materials, parts and finished inventory (and the related information flows) through the organization and its marketing channels in such a way that current and future profitability are maximized through the cost-effective fulfillment of orders.

#### **47. Outbound Logistics**

The process related to the storage and movement of the final product and related information flows from the end of the production line to the end user.

#### **48. Performance Measurement**

Supplier performance measurement and evaluation includes the methods and techniques used to collect information that can be used to measure, rate or rank supplier performance on a continuous basis. The measurement system is a crucial part of supplier management and development.

#### **49. Preventative Maintenance**

The activities, including adjustments, replacements, and basic cleanliness, that forestall machine breakdowns. The purpose is to ensure that production quality is maintained and that delivery schedules are met. In addition, a machine that is well cared for will last longer and cause fewer problems.

#### **50. Program Management**

The coordinated management of a portfolio of projects to achieve a set of business objectives is called program management. Or, a program might refer to an ongoing set of activities internal to the organization, for example, a Total Quality Management program, workplace safety program, supplier development program, etc.

#### **51. Promotions**

One of the four P's (product, price, place, and promotion) that constitute the set of tools used to direct the business offering to the customer. Promotion is the mechanism whereby information about the product offering is communicated to the customer and includes public relations, advertising, sales promotions, and other tools to persuade customers to purchase the product offering.

#### **52. Quality**

Conformance to requirements or fitness for use. Quality can be defined through five principal approaches: (1) Transcendent quality is an ideal, a condition of excellence. (2) Product-based quality is based on a product attribute. (3) User-based quality is fitness for use. (4) Manufacturing-based quality is conformance to requirements. (5) Value-based quality is the degree of excellence at an acceptable price. Also, quality has two major components: (1) quality of conformance—quality is defined by the absence of defects, and (2) quality of design—quality is measured by the degree of customer satisfaction with a product's characteristics and features.

#### **53. Quality Programs**

Some of quality programs that are currently used include:

##### **(TQM):**

TQM is a management approach to long-term success through customer satisfaction. TQM is based on the participation of all members of an organization in improving processes, goods, services, and the culture in which they work.

**(TQE):**

TQE is the discipline of designing quality into the product and manufacturing processes by understanding the needs of the customer and performance capabilities of the equipment.

**(TQC):**

TQC is the process of creating and producing the total composite good and service characteristics by marketing, engineering, manufacturing, purchasing, etc., through which the good and service will meet the expectations of customers.

**(SQC):**

SQC is the application of statistical techniques to control quality.

**54. Six-Sigma Quality:**

Six sigma quality is a term used generally to indicate that a process is well controlled, i.e., tolerance limits are  $\pm 6$  sigma from the centerline in a control chart.

**55. Reverse Logistics**

A supply chain that is dedicated to the reverse flow of products and materials for returns, repair, remanufacture, and/or recycling.

**56. Scheduling**

Scheduling involves taking decisions regarding the allocation of available capacity or resources (equipment, labor and space) to jobs, activities, tasks or customers over time. Scheduling thus results in a time-phased plan, or schedule of activities. The schedule indicates what is to be done, when, by whom and with what equipment. Scheduling seeks to achieve several conflicting objectives: high efficiency, low inventories and good customer service. Scheduling can be classified by the type of process: line, batch and project.

**57. Service Level Agreement**

Service-level agreements (SLAs) are contracts between service providers and customers that define the services provided, the metrics associated with these services, acceptable and unacceptable service levels, liabilities on the part of the service provider and the customer, and actions to be taken in specific circumstances.

**58. Sourcing Strategy**

A successful sourcing strategy requires a thorough understanding of a company's business strategy, the resources required to deliver that strategy, the market forces and the unique risks within the company associated with implementing specific approaches. A periodic review of the sourcing strategy ensures achievement of desired results and continued alignment with business objectives. Some of the sourcing strategies that are used in supply chain management today include:

**Single sourcing:** A method whereby a purchased part is supplied by only one supplier. A JIT manufacturer will frequently have only one supplier for a purchased part so that close relationships can be established with a smaller number of suppliers. These close relationships (and mutual interdependence) foster high quality, reliability, short lead times, and cooperative action.

**Multisourcing:** Procurement of a good or service from more than one independent supplier. Companies may use it sometimes to induce healthy competition between the suppliers in order to achieve higher quality and lower price.

**Outsourcing:** The process of having suppliers provide goods and services that were previously provided internally. Outsourcing involves substitution—the replacement of internal capacity and production by that of the supplier.



**Insourcing:** The goods or services are developed internally.

#### **59. Specifications**

Specifications are the most detailed method of describing requirements. Various types of design specifications are the detailed descriptions of the materials, parts, and components to be used in making a product. Hence, they are the descriptions that tell the seller exactly what the buyer wants to purchase.

#### **60. Standard/Compatibility**

- 1) An established norm against which measurements are compared. (APICS 10th ed.)
- 2) The Internet has transformed supply chain management into something closer to an exact science. However for information to be shared, systems, both hardware and software, must be able to communicate and be compatible so that all supply chain activities can be optimized across company boundaries. Standards promote interoperability and compatibility among operating environments.

#### **61. Statement of Work (S.O.W)**

The most critical ingredient of a successful procurement of services is the development and documentation of the requirements – the statement of work. The S.O.W. identifies what the contractor is to accomplish. It first clearly identifies the primary objective and then the subordinate objectives. One of the goals of the S.O.W. is to gain understanding and agreement with a contractor about the specific nature of the technical activity to be performed. The S.O.W. also impacts the administration of the contract by defining the scope of the contract, that is, what the contractor is supposed to do and the purchaser supposed to receive.

#### **62. Strategic Alliance**

A relationship formed by two or more organizations that share (proprietary), participate in joint investments, and develop linked and common processes to increase the performance of both companies. Many organizations form strategic alliances to increase the performance of their common supply chain.

#### **63. Supplier Development Training**

Education and training is the most common approach to supplier development and improvement. A purchaser may provide training in statistical process control, quality improvement techniques, just-in-time delivery or any other crucial performance area. In order for purchasing to adequately assess and aid suppliers in improving quality, purchasers need to become familiar with the important components of quality management. In many organizations, purchasing may request the assistance of quality and engineering departments in assisting with the supplier quality training. Purchasing companies emphasize four areas of quality training with their suppliers: 1) Total quality management and quality improvement training, 2) statistical quality control techniques training, 3) training focusing on integrating quality into the design of products and processes to reduce variability, and 4) training in problem solving techniques.

#### **64. Supplier Integration in New Product Development**

Supplier integration into new product/process/service development suggests that suppliers are providing information and directly participating in decision making for purchases used in the new product/process/service. This integration can occur during idea generation, preliminary business/technical assessment, product/process/service concept development, product/process/service design and development and prototype build, test or production ramp up.

### 65. Supplier Intelligence

Supplier Intelligence is the purposeful, coordinated and ethical monitoring of strategic suppliers, within a specific marketplace.

### 66. Supplier Performance Evaluation

The main objective of the supplier evaluation process is to reduce purchase risk and maximize the overall value of the purchaser. It typically involves evaluating, at a minimum, supplier quality, cost competitiveness, potential delivery performance and technological capability. Some of the other criteria used in the preliminary evaluation of suppliers include financial risk analysis, evaluation of previous performance, and evaluation of supplier provided information.

### 67. Supplier-Customer Partnership

A long-term relationship between a buyer and a supplier characterized by teamwork and mutual confidence. The supplier is considered an extension of the buyer's organization. The partnership is based on several commitments. The buyer provides long-term contracts and uses fewer suppliers. The supplier implements quality assurance processes so that incoming inspection can be minimized. The supplier also helps the buyer reduce costs and improve product and process designs.

### 68. Supply Chain Design

Supply chain design involves the determination of how to structure a supply chain. Design decisions include the selection of partners, the location and capacity of warehouse and production facilities, the products, the modes of transportation, and supporting information systems.

#### 7.9.3 Addressing the Problems by Supply Chain Management

Supply Chain Management must address the following problems:

- **Distribution Network Configuration:** Number, location and network missions of suppliers, production facilities, distribution centers, warehouses, cross-docks and customers.
- **Distribution Strategy:** Questions of operating control (centralized, decentralized or shared); delivery scheme, e.g., direct shipment, pool point shipping, cross docking, direct store delivery (DSD), closed loop shipping; mode of transportation, e.g., motor carrier, including truckload, Less than truckload (LTL), parcel; railroad; intermodal transport, including trailer on flatcar (TOFC) and container on flatcar (COFC); ocean freight; airfreight; replenishment strategy (e.g., pull, push or hybrid); and transportation control (e.g., owner-operated, private carrier, common carrier, contract carrier, or third-party logistics (3PL)).
- **Trade-Offs in Logistical Activities:** The above activities must be well coordinated in order to achieve the lowest total logistics cost. Trade-offs may increase the total cost if only one of the activities is optimized. For example, full truckload (FTL) rates are more economical on a cost per pallet basis than LTL shipments. If, however, a full truckload of a product is ordered to reduce transportation costs, there will be an increase in inventory holding costs which may increase total logistics costs. It is therefore imperative to take a systems approach when planning logistical activities. These trade-offs are key to developing the most efficient and effective Logistics and SCM strategy.
- **Information:** Integration of processes through the supply chain to share valuable information, including demand signals, forecasts, inventory, transportation, potential collaboration, etc.
- **Inventory Management:** Quantity and location of inventory, including raw materials, work-in-process (WIP) and finished goods.
- **Cash-Flow:** Arranging the payment terms and methodologies for exchanging funds across entities within the supply chain.



#### 7.9.4 Supply Chain Execution

It means managing and coordinating the movement of materials, information and funds across the supply chain. The flow is bi-directional. SCM applications provide real-time analytical systems that manage the flow of product and information throughout the enterprise supply chain network.

Supply chain management is a cross-function approach including in managing the movement of raw materials into an organization, certain aspects of the internal processing of materials into finished goods, and the movement of finished goods out of the organization and toward the end-consumer. As organizations strive to focus on core competencies and becoming more flexible, they reduce their ownership of raw materials sources and distribution channels. These functions are increasingly being outsourced to other entities that can perform the activities better or more cost effectively. The effect is to increase the number of organizations involved in satisfying customer demand, while reducing management control of daily logistics operations. Less control and more supply chain partners led to the creation of supply chain management concepts. The purpose of supply chain management is to improve trust and collaboration among supply chain partners, thus improving inventory visibility and the velocity of inventory movement.

#### 7.9.5 Supply Chain Activities

Several models have been proposed for understanding the activities required to manage material movements across organizational and functional boundaries. SCOR is a supply chain management model promoted by the Supply Chain Council. Another model is the SCM Model proposed by the Global Supply Chain Forum (GSCF). Supply chain activities can be grouped into strategic, tactical, and operational levels. The CSCMP has adopted The American Productivity & Quality Center (APQC) Process Classification Framework a high-level, industry-neutral enterprise process model that allows organizations to see their business processes from a cross-industry viewpoint.

##### Strategic

- Strategic network optimization, including the number, location, and size of warehousing, distribution centers, and facilities.
- Strategic partnerships with suppliers, distributors, and customers, creating communication channels for critical information and operational improvements such as cross docking, direct shipping, and third-party logistics.
- Product life cycle management, so that new and existing products can be optimally integrated into the supply chain and capacity management activities.
- Segmentation of products and customers to guide alignment of corporate objectives with manufacturing and distribution strategy.
- Information technology chain operations.
- Where-to-make and make-buy decisions.
- Aligning overall organizational strategy with supply strategy.
- It is for long term and needs resource commitment.

##### Tactical level

- Sourcing contracts and other purchasing decisions.
- Production decisions, including contracting, scheduling, and planning process definition.
- Inventory decisions, including quantity, location, and quality of inventory.
- Transportation strategy, including frequency, routes, and contracting.
- Benchmarking of all operations against competitors and implementation of best practices throughout the enterprise.

- Milestone payments.
- Focus on customer demand and Habits.

#### **Operational level**

- Daily production and distribution planning, including all nodes in the supply chain.
- Production scheduling for each manufacturing facility in the supply chain (minute by minute).
- Demand planning and forecasting, coordinating the demand forecast of all customers and sharing the forecast with all suppliers.
- Sourcing planning, including current inventory and forecast demand, in collaboration with all suppliers.
- Inbound operations, including transportation from suppliers and receiving inventory.
- Production operations, including the consumption of materials and flow of finished goods.
- Outbound operations, including all fulfillment activities, warehousing and transportation to customers.
- Order promising, accounting for all constraints in the supply chain, including all suppliers, manufacturing facilities, distribution centers, and other customers.
- From production level to supply level accounting all transit damage cases & arrange to settlement at customer level by maintaining company loss through insurance company.
- Managing non-moving, short-dated inventory and avoiding more products to go short-dated.

#### **7.9.6 Specialization era (phase I): outsourced manufacturing and distribution**

In the 1990s, industries began to focus on “core competencies” and adopted a specialization model. Companies abandoned vertical integration, sold off non-core operations, and outsourced those functions to other companies. This changed management requirements by extending the supply chain well beyond company walls and distributing management across specialized supply chain partnerships.

This transition also re-focused the fundamental perspectives of each respective organization. OEMs became brand owners that needed deep visibility into their supply base. They had to control the entire supply chain from above instead of from within. Contract manufacturers had to manage bills of material with different part numbering schemes from multiple OEMs and support customer requests for work -in-process visibility and vendor-managed inventory (VMI).

The specialization model creates manufacturing and distribution networks composed of multiple, individual supply chains specific to products, suppliers, and customers who work together to design, manufacture, distribute, market, sell, and service a product. The set of partners may change according to a given market, region, or channel, resulting in a proliferation of trading partner environments, each with its own unique characteristics and demands.

#### **7.9.7 Specialization era (phase II): supply chain management as a service**

Specialization within the supply chain began in the 1980s with the inception of transportation brokerages, warehouse management, and non-asset-based carriers and has matured beyond transportation and logistics into aspects of supply planning, collaboration, execution and performance management.

At any given moment, market forces could demand changes from suppliers, logistics providers, locations and customers, and from any number of these specialized participants as components of supply chain networks. This variability has significant effects on the supply chain infrastructure, from the foundation layers of establishing and managing the electronic communication between the trading partners to more complex requirements including the configuration of the processes and work flows



that are essential to the management of the network itself.

Supply chain specialization enables companies to improve their overall competencies in the same way that outsourced manufacturing and distribution has done; it allows them to focus on their core competencies and assemble networks of specific, best-in-class partners to contribute to the overall value chain itself, thereby increasing overall performance and efficiency. The ability to quickly obtain and deploy this domain-specific supply chain expertise without developing and maintaining an entirely unique and complex competency in house is the leading reason why supply chain specialization is gaining popularity.

Outsourced technology hosting for supply chain solutions debuted in the late 1990s and has taken root primarily in transportation and collaboration categories. This has progressed from the Application Service Provider (ASP) model from approximately 1998 through 2003 to the On-Demand model from approximately 2003-2006 to the Software as a Service (SaaS) model currently in focus today.

### **7.9.8 Supply chain management 2.0 (SCM 2.0)**

Building on globalization and specialization, the term SCM 2.0 has been coined to describe both the changes within the supply chain itself as well as the evolution of the processes, methods and tools that manage it in this new "era". The growing popularity of collaborative platforms is highlighted by the rise of TradeCard's supply chain collaboration platform which connects multiple buyers and suppliers with financial institutions, enabling them to conduct automated supply chain finance transactions.[13]

Web 2.0 is defined as a trend in the use of the World Wide Web that is meant to increase creativity, information sharing, and collaboration among users. At its core, the common attribute that Web 2.0 brings is to help navigate the vast amount of information available on the Web in order to find what is being sought. It is the notion of a usable pathway. SCM 2.0 follows this notion into supply chain operations. It is the pathway to SCM results, a combination of the processes, methodologies, tools and delivery options to guide companies to their results quickly as the complexity and speed of the supply chain increase due to the effects of global competition, rapid price fluctuations, surging oil prices, short product life cycles, expanded specialization, near-/far- and off-shoring, and talent scarcity.

SCM 2.0 leverages proven solutions designed to rapidly deliver results with the agility to quickly manage future change for continuous flexibility, value and success. This is delivered through competency networks composed of best-of-breed supply chain domain expertise to understand which elements, both operationally and organizationally, are the critical few that deliver the results as well as through intimate understanding of how to manage these elements to achieve desired results. Finally, the solutions are delivered in a variety of options, such as no-touch via business process outsourcing, mid-touch via managed services and software as a service (SaaS), or high touch in the traditional software deployment model.

## **7.10 SOFTWARE TOOLS (SPREAD SHEET TO BI APPLICATION)**

Technology powers many things in our daily lives from cell phones to toys, computers to televisions. When normal day-to-day activity depends on technology, it's essential that technology runs correctly. In careers and recreation, life can come to an irritatingly grinding halt when technology doesn't work correctly.

Software tools, also known as programming tools, are necessary to keeping your technology running without a hitch. Software tools are programs that software developers create debug, maintain, and support other systems. Software tools are usually relatively simple programs that can be combined together to perform more than one task. Software tools can do any number of tasks including:

- Analyze performance
- Debug



- Check accuracy
- Build applications
- Check and adjust memory usage
- Linking and integrating
- Text editors

There are also Integrated Development Environments (IDE), which combined different software tools into a simpler package that makes it easier to use. These IDE Environments are an exciting new concept that's been a long time coming. So many businesses have been seeking a solution like this one for so long. They are easy to implement, and provide companies with exactly what they need.

### 7.10.1 Why Are They Important?

Software tools are important to computer usage, or to anyone who uses technology daily. Software tools protect computers from crashing, keep them running accurately, and help make sure the memory is being used in the most efficient way. Computers hold extremely important data, whether they are business computers or personal computers, and often people forget to save their data to other removable storage disks. Software tools decrease the potential of losing important information and increase the performance of the computer itself.

### 7.10.2 Spread Sheet

A **spreadsheet** is a program designed specifically for processing data in tabular form. These data may be numerical or textual, although most of the functions of a spreadsheet are for the former kind.

The spreadsheet is modelled on the paper device once used by accountants for tabulating numerical figures—a large sheet of paper spread out to show the financial state of a business. Apart from its ease of correction the electronic version differs from the paper spreadsheet principally in its database and numerical functions, most notably sorting and the ability to display the results of formulae which depend on values entered elsewhere in the sheet. Automatic calculation and graphical display have meant a radical increase in speculative, “as if” presentations, which has made the spreadsheet an essential tool of all commercial business and certain kinds of academic research. The rapidity with which graphical displays may be generated from quantitative information represents a potential for communication of facts and ideas that may as easily be abused as used. Hence the increased need, explored in this course, for understanding visual forms.

Spreadsheet software allows you to

- create simple lists and tables of alphabetic or numerical data
- create and manipulate simple (flat-file) databases
- establish relationships between sets of numerical data
- apply arithmetic, mathematical or statistical functions to numerical datasets
- represent datasets in graphical or chart form

In the humanities, potential uses of spreadsheets include:

- maintaining lists of short items you wish to sort, e.g. vocabulary, categories, instances of phenomena
- studying quantifiable information, such as word-distributions across textual corpora; demographics; other sociological statistics; voting patterns; inventories; etc.
- managing budgets, e.g. for grant applications and project expenses

### 7.10.3 Software Programs and Documentation

*Excel* (a Microsoft product) is used in this course and easily available commercially. It is the dominant product of its kind. But as with other long-established kinds of software, many other products are available, including some very effective alternatives that are free of charge.

The range of functions needed by most students in the humanities represents only a small fraction of what *Excel* and other such programs commonly offer. Books documenting them are in general both expensive and difficult to use. None of these is recommended because you are unlikely to need the majority of the information they provide, and they are quite poor at explaining some of the simplest functions.

### 7.10.4 Definitions and Terminology

#### Structure

A **spreadsheet** (or **worksheet**) is a table of *rows* and *columns*, as shown in the sample image below from Excel.

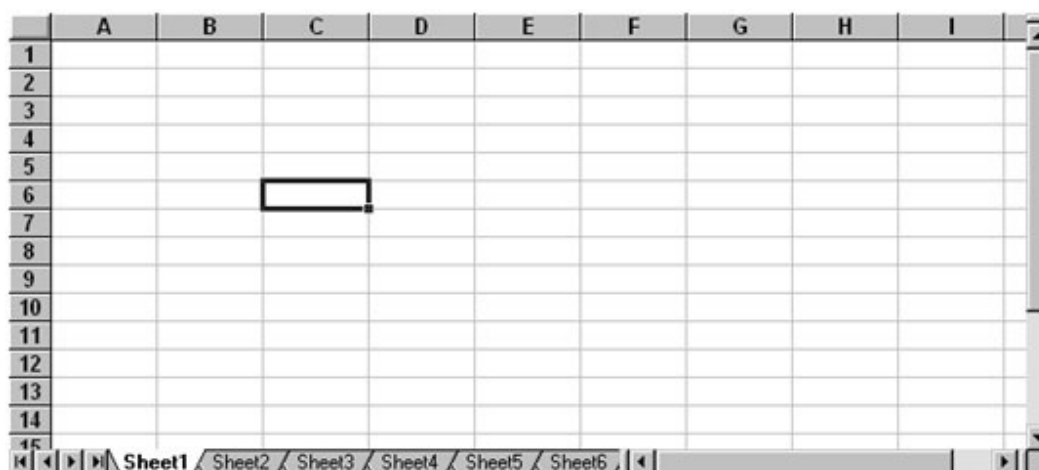

Note that

- The rows are identified by number (1, 2, 3, ... 16384), the columns by letter (A, B, C, ... Z, AA, AB, ... AZ, BA, ... ZZ)
- The intersection of a row with a column, called a **cell**, is uniquely identified by its column and row designators, e.g. A2, B10, J13
- A cell may contain text, a number or a formula.

Because cells may be referenced within formulas, spreadsheet software makes a distinction between **Relative** and **Absolute** references. See the sections on Formulas and Referencing, in "Basic operations".

In Excel, worksheets are kept in **workbooks**, i.e. Excel files that may contain up to 255 worksheets. A workbook is a useful organizational device, since you can keep in it all the sheets related to a particular project and the charts related to them. Note in the above image the tabs for the sheets in the current workbook.

#### Useful Terms

The following terms are commonly used to refer to parts of the spreadsheet:

1. **Mouse cursor**: the pointer that in Excel takes the form of a cross (2 types, depending on location) or an "insertion point" (a vertical bar with cross-bars top and bottom, like the letter "I").
2. **Active cell**: the current or selected cell (in the above image, cell C6)

3. **Cell reference:** the unique designator for a cell

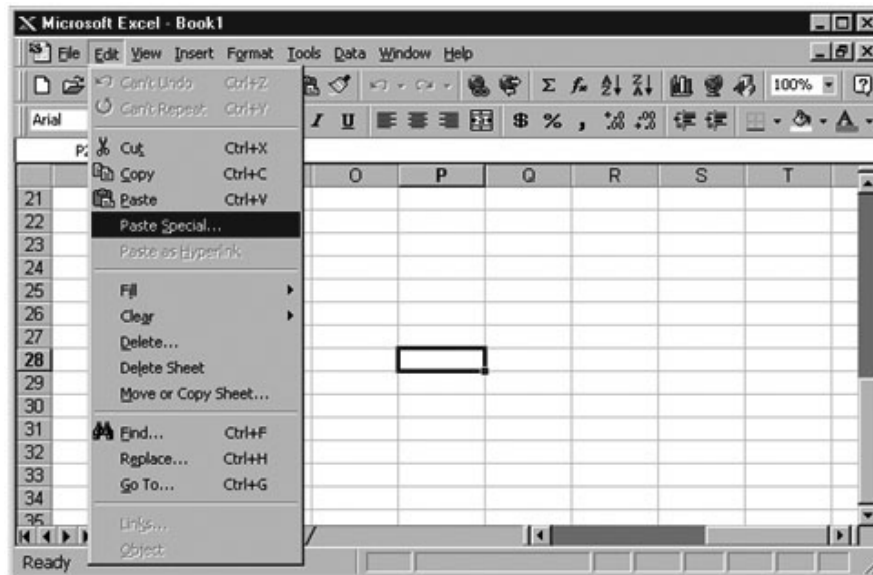
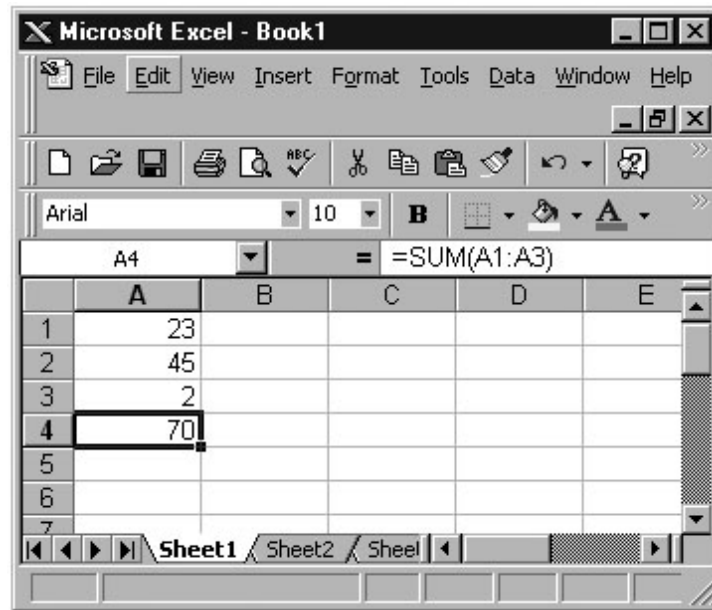

4. **Menu bar:** the horizontal area at the top of the Excel window containing the names of the various "drop-down" menus. In the example at right, the menu bar is shown with the Edit menu activated.
5. **Toolbar:** two horizontal areas below the menu bar containing buttons, each with an icon representing the operations performed by the tool; these consist of the **standard toolbar** and the **formatting toolbar**. Moving the cursor onto the button causes an explanatory caption for it to be displayed briefly. See the above image.
6. **Formula:** an expression entered into a cell that is designed to be evaluated by the spreadsheet software.
7. **Formula bar:** the horizontal area beneath the toolbar and to the right, where formulas are displayed when they are entered and whenever a cell containing a formula is selected. In the example at right, cell A4 contains the formula displayed in the formula bar.

8. **Sheet tabs:** the tab-like entities at the bottom of the workbook area, designated by “Sheet 1”, “Sheet 2”, and so forth, as shown here. Clicking on a tab causes the named sheet to be displayed. The **active sheet tab** is the one currently selected, here Sheet 1. Note the **tab scrolling buttons** to the left of the tabs; these cause the currently displayed set of sheet tabs to be rotated to the right or left.
9. **Vertical scroll bar:** in the image above, the bar at the right-hand edge of the Excel window, used for scrolling up and down the sheet; similarly the **horizontal scroll bar** is used for right- and left-scrolling.

## 7.11 DIFFERENT RESOURCES OF TECHNOLOGY - DATA WAREHOUSE, BUSINESS INTELLIGENCE SYSTEM

### 7.11.1 Data Warehousing

Data warehousing is the science of storing data for the purpose of meaningful future analysis.

Yes, it is a science (not much art involved!) and it deals with the mechanism of electronically storing and retrieving data so that some analysis can be performed on that data to corroborate support a business decision or to predict a business outcome.

DW technologies provide historical, current and predictive views of business operations by analyzing the present and historical business data. Data analysis is often done using visualization techniques that turn complex data into images that tells compelling story. Raw data by this process of analysis help management take right decisions.

To further demonstrate the need of data warehousing, consider this.

Let's imagine a company called “FairShop” that has 1000 retail outlets across USA. The company has built one data warehouse to store the data collected from all the shop outlets so that they can analyze the data to gather business intelligence.

The company collects raw sales data from all of their outlet shops (through a process called ETL) and then load them into a place called data warehouse or data mart.

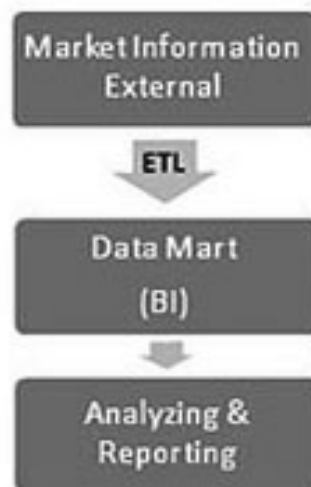

Once the data is there in data warehouse (or data mart) business intelligence techniques are applied to that data for analysis and reporting. Since the company now has the sales and purchase information from all their shops in a centralized place, it can easily use this data to answer some rudimentary questions about their business e.g. what shop makes highest sales, which product is most popular across the shop, what is the stock balance etc.

It is very common to talk about both data warehousing and business intelligence together since business intelligence in this context refers to analyzing the data in data warehouse. As Wikipedia puts it:

“Common functions of business intelligence technologies are reporting, online analytical processing, analytics, data mining, process mining, complex event processing, business performance management, benchmarking, text mining and predictive analytics.”

### **Building the definition of data warehouse**

There are couple of points to notice from the typical retail scenario shown above. These points form the base of our discussion on the definition.

1. Objective of building a data warehouse is to store data that are required for analysis and reporting
2. For a data warehouse to function, it should be supplemented with a process that can collect and load data into it (e.g. ETL)
3. In a data warehouse, data actually flows from the source to target - so the contents of the data warehouse would be different between 2 given points in time

Now if I tell you that, the definition of data warehouse can be constructed from the above 3 points - that shouldn't surprise you. But what will surprise you is - a lot of these points are not really considered in the classic definition of data warehouse.

So let's discuss the classic definitions of data warehouse first.

Classic Definition of Data Warehouse - A peek in the history

The history of data warehouse dates back to 1960. Without going into detail, here we will quickly touch upon a few noteworthy events of the history of data warehouse. In 1970, ACNielsen, a global marketing research company, published sales data pertaining to retail industry in the form of dimensional data mart.

Earlier than this, the concept of data warehouse for analysis was only a subject of academic pursuit.

Along the same time, the concept of decision support system were gradually developing and people started to realize that data stored in operational systems (e.g. data stored in the individual stores of a retail chain) are not easy to analyze in the time of decision making. So in 1983, Teradata introduced a database management system specifically designed for decision support.

In this decade and next, several people experimented with several designs of data warehouse and some of them were quite successful. In the year 1992, one of them, named Bill Inmon published a book - Building the Data Warehouse - which among other things, gave us a widely accepted definition of what a data warehouse is. We will soon jump into that definition. But before that let me mention one more author - Ralph Kimball - who 4 years later in 1996 wrote another book - Data warehouse toolkit - showing us yet another approach of defining and building a data warehouse. Since then, both Inmon and Kimball approaches are widely accepted and implemented throughout the globe.

So How did Bill Inmon defined a data warehouse? Here it is:

A data warehouse is a subject oriented, non-volatile, integrated, time variant collection of data in support of management's decisions.

Now let's understand this definition.

Explanation on the classic definition of data warehouse

### **Subject Oriented**

This means a data warehouse has a defined scope and it only stores data under that scope. So for example, if the sales team of your company is creating a data warehouse - the data warehouse by definition is required to contain data related to sales (and not the data related to production management for example)



### **Non-volatile**

This means that data once stored in the data warehouse are not removed or deleted from it and always stay there no matter what.

### **Integrated**

This means that the data stored in a data warehouse make sense. Fact and figures are related to each other and they are integrable and projects a single point of truth.

### **Time variant**

This means that data is not constant, as new and new data gets loaded in the warehouse, data warehouse also grows in size.

### **Identifying a data warehouse based on its definition**

4 simple terms by Inmon defined data warehouse succinctly. Let's now check how the definition help us identify a data warehouse from other types of data stores.

Is a book written on how to create 17 different peas pudding, a data warehouse? It is subject oriented (deals with peas pudding), Non-volatile (deals with fixed 17 methods that are there to stay), integrated (makes sense). But it's not time variant. Answer is it's not a data warehouse.

So is the folder on my desktop named "Account Statements" a data warehouse? Subject oriented (deals with financial accounting), non-volatile (until I manually delete it), Time variant (every month new account statements pour in) but it's not integrated (one file in the folder containing the account statement from bank XYZ for the month of May has no way to link to the other file in the folder containing the account statement of the bank ABC for the month of June). So - not a data warehouse.

So is the sales information collected in one store of a big retail chain a data warehouse? It's subject oriented, time variant and integrated (after all there is a relational database behind). But is it non-volatile? Mostly not. And even if it is - there is a fifth factor. Is it being used for the purpose of management decision making? Surely not. After all who will take an enterprise wide management decision based on the data collected from a single store?

### **A broader definition of data warehouse**

The classic definition that we discussed above does not focus much on the purpose of the data warehouse. The purpose is something which distinguishes a data warehouse from a data mart if you will and help us understand the need of the data warehouse. The purpose of a data warehouse, as we discussed before, is to render a timely data-driven insight that was otherwise inconceivable directly from the raw data. A data warehouse which stores data, is time variant and subject oriented and integrated yet does not solve this purpose - is no better than just a data dump.

An alternative (and more concurrent) definition of data warehouse will be:

A data warehouse is an electronically stored collection of integrated data that can be used for the purpose of intelligent analysis.

Dropping the time variance from the above definition broadens the coverage of the definition and omission of non-volatility condition makes the definition more realistic rather than idealistic. There are many data that are not time variant (historical and scientific data) but can be stored in a data warehouse for analysis. Similarly modern data warehouses are purged regularly when the data lose its purpose. Adding a sense of purpose in the definition enables us to create a more reliable and goal-oriented data warehouse.

### Schematic View of a data warehouse

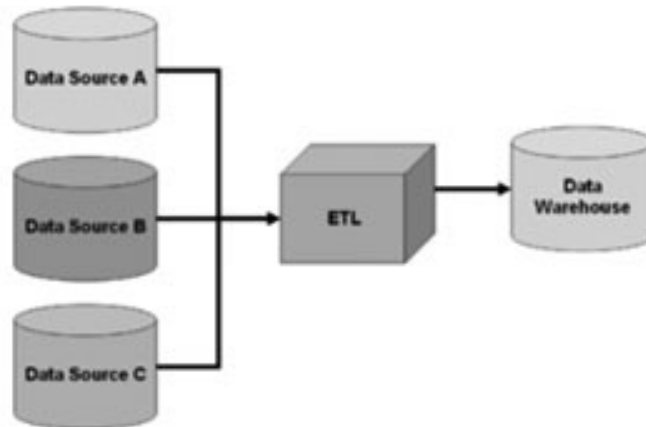

The diagram above shows a typical schematic structure of a data warehouse. As one can see here, most data warehouses collect data from multiple sources to form one integrated warehouse. Before loading to the warehouse, these data often need special treatment which is done in the ETL layer (ETL - Extraction, Transformation, Loading). ETL layer is mostly responsible for 2 types of treatments on the data:

- Data Integration - So that some links can be established between data coming from separate systems, and
- Qualitative Treatment - so that the validity and quality of the data can be checked (and if required corrected) before loading to the data warehouse.

#### 7.11.2 Business Intelligence (BI)

Business Intelligence (BI) is the ways in which we store and use business information. It encompasses the technologies, applications, and means for collecting, integrating, analyzing, and presenting business data. Using data that has been stored in a data warehouse, software applications are able to use this data to report past business information as well as predict future business information, including trends, threats, opportunities and patterns. Popular BI applications are very complex and experts in this field are in high demand. Some of the currently popular enterprise level systems, which can manage information about all of the business functions and systems, are sold and implemented by Oracle, SAP, IBM, and Hewlett Packard (HP). Companies often need in-house experts in these systems to assist with the implementation and the on-going use of these systems, which are quite complex!

Business Intelligence is becoming a critically important tool that can allow your company to better understand your customers and suppliers, or measure the efficiency of your own internal operations. If you are new to BI, try reading our Business Intelligence Overview first. Now, it's time to start planning a new BI project. You will need to design the right BI solution for the kind of analysis you plan to do, and evaluate your existing IT infrastructure to ensure that it can support this kind of solution.

#### Choosing the Right BI Solution

BI tools offer functionality ranging from simple reports to drill-down analytical solutions targeted at specific industries and operational environments. When choosing a Business Intelligence solution, firms need to ask two key questions:

1. What kind of data needs to be analyzed and where does it come from?

Many packaged application and database vendors include some BI functionality in their core product, and if you plan to source all of your data from the same application or database, you may not need to buy additional products. However, this strategy may also limit the analytical range.



2. Who will be doing the analysis and how do they need to receive the results?

Historically, report or analysis requests would be sent to the IT department, which would then code and generate the report. Today, BI is on the front lines of business and the tools may well be used by executives or sales and marketing professionals. As a result, firms need to know the technical capabilities of the end user upfront.

### The Business Intelligence Technology Stack

To build a Business Intelligence solution, enterprises will need to consider new investments and upgrades to current technology to build out the BI technology stack. The technology stack is designed to highlight the different layers of technology that will be affected by a BI project, all the way from the hardware hosting your data at the bottom of the stack to the portal product used to present information to users at the top. Starting from the bottom, this seven-layer stack includes:

1. **Storage and computing hardware:** To implement BI, firms will need to invest or upgrade their data storage infrastructure. This includes Storage Area Networks (SAN), Network Attached Storage (NAS), Hierarchical Storage Management (HSM), and silo-style tape libraries. The trend over the next five years is for storage resources to be amalgamated into a single, policy-managed, enterprise-wide storage pool.
2. **Applications and data sources:** To develop an effective BI solution, source data will need to be scrubbed and organized. The challenge is that source data can come from any number of applications, most using proprietary data formats and application-specific data structures. Customer Relationship Management (CRM), Supply Chain Management (SCM), and Enterprise Resource Planning (ERP) systems, and other applications are the common sources of data. The trend over the next five years will be for applications to standardize the data format using eXtensible Markup Language (XML) schema and leverage BI specific standards like XML for Analysis.
3. **Data integration:** Middleware allows different systems supporting different communication protocols, interfaces, object models, and data formats to communicate. Firms will need to invest in these "connectors" to allow data from source applications to be integrated with the BI repository. Extraction, transformation and loading (ETL) tools pull data from multiple sources, and load the data into a data warehouse. Again, the trend in data integration and Enterprise Application Integration, in general, is toward standardization through XML and web services.
4. **Relational databases and data warehouses:** Firms will need a data warehouse to store and organize tactical or historical information in a relational database. Organizing data in this way allows the user to extract and assemble specific data elements from a complete dataset to perform a variety of analyses.
5. **OLAP applications and analytic engines:** Online analytic processing (OLAP) applications provide a layer of separation between the storage repository and the end user's analytic application of choice. Its role is to perform special analytical functions that require high-performance processing power and more specialized analytical skills.
6. **Analytic applications:** Analytic applications are the programs used to run queries against the data to perform either "slide-and-dice" analysis of historical data or more predictive analyses, often referred to as "drill-down" analysis. For example, a customer intelligence application might enable a historical analysis of customer orders and payment history. Alternatively, users could drill down to understand how changing a price might affect future sales in a specific region.
7. **Information presentation and delivery products:** The results of a query can be returned to the user in a variety of ways. Many tools provide presentation through the analytic application itself and offer dashboard formats to aggregate multiple queries. Also, enterprises can purchase packaged or custom reporting products, such as Crystal Reports. An important trend in BI presentation is leveraging XML to deliver analyses through a portal or any other Internet-enabled interface, such as a personal digital assistant (PDA).



### How do Business Intelligence (BI) and Performance Management (PM) Fit Together?

Are BI and PM different words for a species of bird or two different birds ... or animals? Is BI part of PM? Or is PM part of BI?

There is ambiguity because the underlying inputs, processes, outputs and outcomes of an organization - whether a public sector government agency or a commercial business - may arguably have some parts that belong to BI, while others belong to PM. The key word in that sentence was "arguably." This argument arises because IT-centric people often see an enterprise as a ravenous consumer of billions of bytes of data intended to manage the business (a BI view). In contrast, leaders, managers and employee teams typically view the same enterprise as an organism with a purpose and mission (a PM view); they desire solutions and applications that achieve results. How can BI and PM be reconciled? The enterprise is like that single species of bird - nothing can change its existence in reality.

### How do Business Intelligence and Performance Management Relate to Each Other?

There are two things related to this topic that most folks can agree upon: 1) BI involves raw data that must first be integrated from disparate source systems and then transformed into information; and 2) PM leverages that information. In this context, information is much more valuable than data points, because integrating and transforming data using calculations and pattern discovery results in potentially meaningful information that can be used for decisions. For example, an automobile manufacturer's warranty claims can be globally analyzed to detect a design problem. In another instance, the history of an individual's credit card purchase transaction data can be converted to information that, in turn, can be used for decisions by retailers to better serve the customer or provide customized offers to sell more to them.

A recent survey by the global technology consulting firm Accenture reported that senior U.S. executives are increasingly more disenchanted with their analytic and BI capabilities.<sup>2</sup> Although they acknowledged that their BI (regardless of how they personally define it) provides a display of data in terms of reporting, querying, searching and visual dashboards, they felt their mainstream BI still fell short. An organization's interest is not just to monitor the dials; it is, more importantly, to move the dials. That is, merely reporting information does equate to managing for better results. Actions and decisions are needed to improve the organization's performance. Having mainstream BI capability is definitely important; however, it often came about as the result of departments needing advances that their IT function could not provide. Extending BI across the organization so that mini-BI applications can talk is a mission-critical differentiator for organizational success and competitiveness.

Managing and improving are not the same thing. Many people are managers, like a coach of a sports team, and they get by. Improving, on the other hand, is how an organization wins. To differentiate BI from PM, performance management can be viewed as deploying the power of BI, but the two are inseparable. Think of PM as an application of BI. PM adds context and direction for BI. As in physics, BI is like potential energy, while PM is the conversion of potential energy into kinetic energy. Coal, when heated, provides power to move things. Using a track-and-field analogy, BI is like the muscle of a pole-vaulter, and PM is that same athlete clearing higher heights. BI is an enterprise information platform for querying, reporting and much more, making it the foundation for effective performance management. PM drives the strategy and leverages all of the processes, methodologies, metrics and systems that monitor, manage and, most importantly, improve enterprise performance. Together, BI and PM form the bridge that connects data to decisions.

With PM, the strategy spurs the application of technology, methodologies and software. As methodologies - which are typically implemented or operated in isolation of each other - are integrated, the strength and power of PM grows. Technologies, such as software, support the methodologies. Software is an essential enabler, but the critical part is in the thinking. That is, one must understand the assumptions used in configuring commercial software and, more importantly, have a vision of the emerging possibilities to apply the new knowledge that BI and PM produces.



## 7.12 SCORECARDS AND DASHBOARD, DECISION SUPPORT SYSTEMS, MANAGEMENT INFORMATION SYSTEMS, OLAP - ONLINE ANALYTICAL PROCESSING TOOLS

### 7.12.1 Balanced Scorecard

The balanced scorecard is a strategic planning and management system that is used extensively in business and industry, government, and nonprofit organizations worldwide to align business activities to the vision and strategy of the organization, improve internal and external communications, and monitor organization performance against strategic goals. It was originated by Drs. Robert Kaplan (Harvard Business School) and David Norton as a performance measurement framework that added strategic non-financial performance measures to traditional financial metrics to give managers and executives a more 'balanced' view of organizational performance. While the phrase balanced scorecard was coined in the early 1990s, the roots of this type of approach are deep, and include the pioneering work of General Electric on performance measurement reporting in the 1950's and the work of French process engineers (who created the Tableau de Bord – literally, a “dashboard” of performance measures) in the early part of the 20th century.

The balanced scorecard has evolved from its early use as a simple performance measurement framework to a full strategic planning and management system. The “new” balanced scorecard transforms an organization's strategic plan from an attractive but passive document into the “marching orders” for the organization on a daily basis. It provides a framework that not only provides performance measurements, but helps planners identify what should be done and measured. It enables executives to truly execute their strategies.

This new approach to strategic management was first detailed in a series of articles and books by Drs. Kaplan and Norton. Recognizing some of the weaknesses and vagueness of previous management approaches, the balanced scorecard approach provides a clear prescription as to what companies should measure in order to 'balance' the financial perspective. The balanced scorecard is a management system (not only a measurement system) that enables organizations to clarify their vision and strategy and translate them into action. It provides feedback around both the internal business processes and external outcomes in order to continuously improve strategic performance and results. When fully deployed, the balanced scorecard transforms strategic planning from an academic exercise into the nerve center of an enterprise.

Kaplan and Norton describe the innovation of the balanced scorecard as follows:

“The balanced scorecard retains traditional financial measures. But financial measures tell the story of past events, an adequate story for industrial age companies for which investments in long-term capabilities and customer relationships were not critical for success. These financial measures are inadequate, however, for guiding and evaluating the journey that information age companies must make to create future value through investment in customers, suppliers, employees, processes, technology, and innovation.”

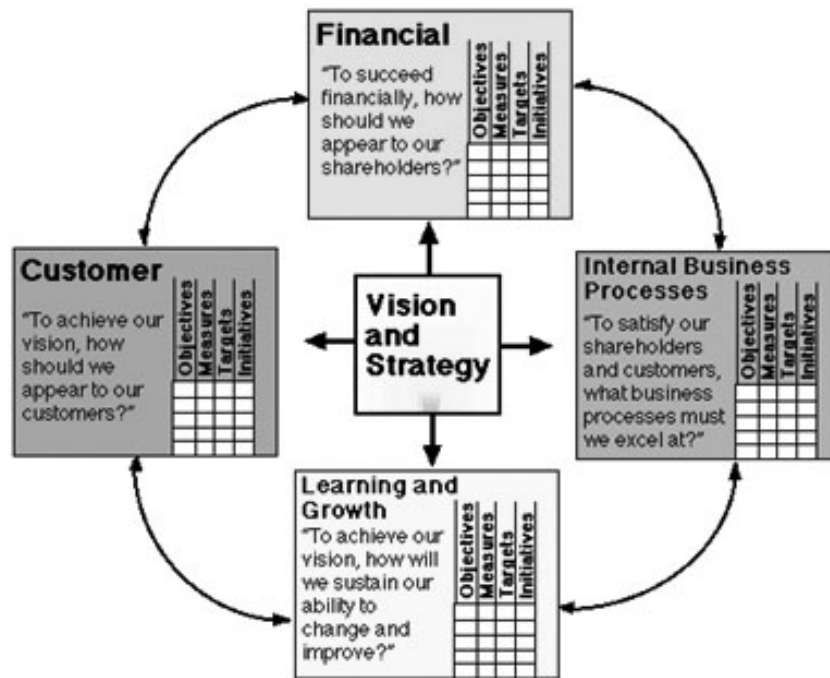

Adapted from Robert S. Kaplan and David P. Norton, "Using the Balanced Scorecard as a Strategic Management System," Harvard Business Review (January-February 1996): 76.

### Perspectives

The balanced scorecard suggests that we view the organization from four perspectives, and to develop metrics, collect data and analyze it relative to each of these perspectives:

#### The Learning & Growth Perspective

This perspective includes employee training and corporate cultural attitudes related to both individual and corporate self-improvement. In a knowledge-worker organization, people -- the only repository of knowledge -- are the main resource. In the current climate of rapid technological change, it is becoming necessary for knowledge workers to be in a continuous learning mode. Metrics can be put into place to guide managers in focusing training funds where they can help the most. In any case, learning and growth constitute the essential foundation for success of any knowledge-worker organization.

Kaplan and Norton emphasize that 'learning' is more than 'training'; it also includes things like mentors and tutors within the organization, as well as that ease of communication among workers that allows them to readily get help on a problem when it is needed. It also includes technological tools; what the Baldrige criteria call "high performance work systems."

#### The Business Process Perspective

This perspective refers to internal business processes. Metrics based on this perspective allow the managers to know how well their business is running, and whether its products and services conform to customer requirements (the mission). These metrics have to be carefully designed by those who know these processes most intimately; with our unique missions these are not something that can be developed by outside consultants.

#### The Customer Perspective

Recent management philosophy has shown an increasing realization of the importance of customer focus and customer satisfaction in any business. These are leading indicators: if customers are not



satisfied, they will eventually find other suppliers that will meet their needs. Poor performance from this perspective is thus a leading indicator of future decline, even though the current financial picture may look good.

In developing metrics for satisfaction, customers should be analyzed in terms of kinds of customers and the kinds of processes for which we are providing a product or service to those customer groups.

### **The Financial Perspective**

Kaplan and Norton do not disregard the traditional need for financial data. Timely and accurate funding data will always be a priority, and managers will do whatever necessary to provide it. In fact, often there is more than enough handling and processing of financial data. With the implementation of a corporate database, it is hoped that more of the processing can be centralized and automated. But the point is that the current emphasis on financials leads to the “unbalanced” situation with regard to other perspectives. There is perhaps a need to include additional financial-related data, such as risk assessment and cost-benefit data, in this category.

### **Strategy Mapping**

Strategy maps are communication tools used to tell a story of how value is created for the organization. They show a logical, step-by-step connection between strategic objectives (shown as ovals on the map) in the form of a cause-and-effect chain. Generally speaking, improving performance in the objectives found in the Learning & Growth perspective (the bottom row) enables the organization to improve its Internal Process perspective Objectives (the next row up), which in turn enables the organization to create desirable results in the Customer and Financial perspectives (the top two rows).

### **Balanced Scorecard Software**

The balanced scorecard is not a piece of software. Unfortunately, many people believe that implementing software amounts to implementing a balanced scorecard. Once a scorecard has been developed and implemented, however, performance management software can be used to get the right performance information to the right people at the right time. Automation adds structure and discipline to implementing the Balanced Scorecard system, helps transform disparate corporate data into information and knowledge, and helps communicate performance information.

### **7.12.2 Dashboard**

In information technology, a dashboard is a user interface that, somewhat resembling an automobile's dashboard, organizes and presents information in a way that is easy to read. However, a computer dashboard is more likely to be interactive than an automobile dashboard (unless it is also computer-based). To some extent, most graphical user interfaces (GUIs) resemble a dashboard. However, some product developers consciously employ this metaphor (and sometimes the term) so that the user instantly recognizes the similarity.

Some products that aim to integrate information from multiple components into a unified display refer to themselves as dashboards. For example, a product might obtain information from the local operating system in a computer, from one or more applications that may be running, and from one or more remote sites on the Web and present it as though it all came from the same source. Hewlett Packard developed the first such product, which began as a tool for customizing Windows desktops. Called Dashboard, the HP product was subsequently acquired by Borland and then a company called Starfish. Microsoft's Digital Dashboard tool incorporates Web-based elements (such as news, stock quotes, and so on) and corporate elements (such as e-mail, applications, and so on) into Outlook. Dashboards may be customized in a multitude of ways and named accordingly, generally, for example as a general corporate or enterprise dashboard, or more specifically, as a CIO or CEO dashboard.

The two terms – scorecards and dashboards – have a tendency to confuse, or rather get used interchangeably, but each brings a different set of capabilities. The sources of the confusion are:

- Both represent a way to track results.

- Both use traffic lights, dials, sliders and other visual aids.
- Both have targets, thresholds and alert messages.
- Both provide linkage or drill down to other metrics and reports.

The difference comes from the context in how they are applied. To provide some history, as busy executives and managers struggled to keep up with the amount of information being thrust at them, the concept of traffic lighting were applied to virtually any and all types of reporting. As technology has improved, more bells and whistles were added – the ability to link to other reports and to drill down to finer levels of detail. The common denominator was the speed of being able to focus on something that required action or further investigation. The terminology evolved to reflect how technology vendors described the widgets that provided this capability – dashboards. As a consequence, both dashboard and scorecard terms are being used interchangeably.

The following figure illustrates the difference between scorecards and dashboards using a taxonomy. Scorecards and dashboards are not contradictory; they are used for different purposes.

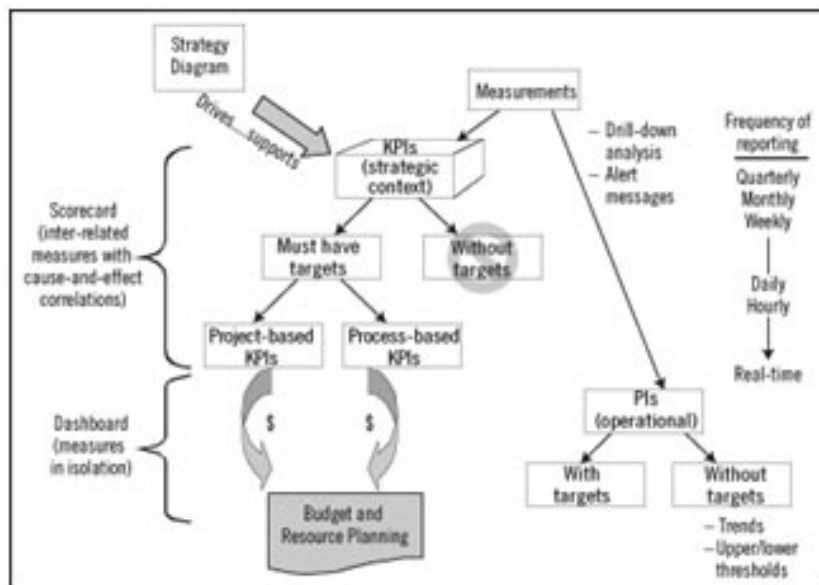

**Fig: Difference between Scorecards and Dashboards Using Taxonomy**

At the top portion of the figure is the realm of scorecards. Scorecards are intended to be *strategic*. They align the behavior of employees and partners with the strategic objectives formulated by the executive team. In contrast, dashboards, at the bottom portion of the figure, are intended to be *operational*.

Some refer to dashboards as “dumb” reporting and scorecards as “intelligent” reporting. The reason is dashboards are primarily for data visualization; they display what is happening during a time period. Most organizations begin with identifying what they are already measuring and construct a dashboard dial from there. However, dashboards do not communicate why something matters, why someone should care about the reported measure or what the impact may be if an undesirable declining measure continues. In short, dashboards report what you can measure.

### 7.12.3 Decision Support Systems

In a world of constant flux, informed and thoughtful decision-making is the cornerstone of business success. As a manager, you must make decisions that affect your business every day, some critical and some not so important. Decision Support Systems allow faster decision making, identification of negative trends, and better allocation of business resources all to the benefit of you and your organization.



Decision Support Systems - DSS - are a specific class of computer-based information systems that support your decision-making activities. A decision support system analyzes business data and provide interactive information support to managers and business professionals during the decision-making process, from problem recognition to implementing your decision. Decision Support Systems use (1) Analytical models, (2) specialized databases, (3) a decision maker's own insights and judgments, and (4) an interactive, computer-based modeling process to support semi-structured business decisions.

A key component to any DSS is Business Intelligence reporting tools, processes, and methodologies. These provide you with rich reporting, monitoring, and data analysis, which are necessary for effective and fast decision-making.

**Support Business Decision Making:** In an increasingly competitive global business environment you cannot ponder over decisions for too long. As a manager today, you must be making more decisions than ever before - and you also have to make them faster than ever before. That is why your business needs managers who can take snap decisions and execute the outlined strategy.

The entire decision-making process, from problem recognition to action, has become so accelerated it is simply impossible to rely on human response alone. That is why companies need a Decision Support System that will help you react and adapt to the constantly changing business environment you must relate to.

Therefore, to succeed in business today, your company needs information systems that can support the diverse information and decision-making needs of you and your company and support you in making snap decisions. Decision Support Systems helps you assess and resolve everyday business questions by compiling useful information from a combination of raw data, documents, personal knowledge, or business models.

**Gain competitive advantage with Decision Support Systems:** In today's competitive business environment, what you need for maximum performance is to achieve competitive advantage. Without competitive advantage, your company will not be able to operate and will eventually cease to exist.

One way of gaining competitive advantage is through the use of computerized Decision Support Systems. The simplest and most tangible benefit of a Decision Support System is the ability to help you toward making better decisions. Your decisions are better in the sense that, once they are implemented, they have such effect as reducing costs, using assets more efficiently, increasing revenue, reducing risks, improving customer service, and so on.

However, Decision Support Systems can provide your company with many other benefits including:

- Speeding up process of decision making
- Increasing organizational control
- Speeding up problem solving in an organization
- Helping automate managerial processes
- Improving personal efficiency
- Eliminating value chain activities

## Components of Decision Support Systems

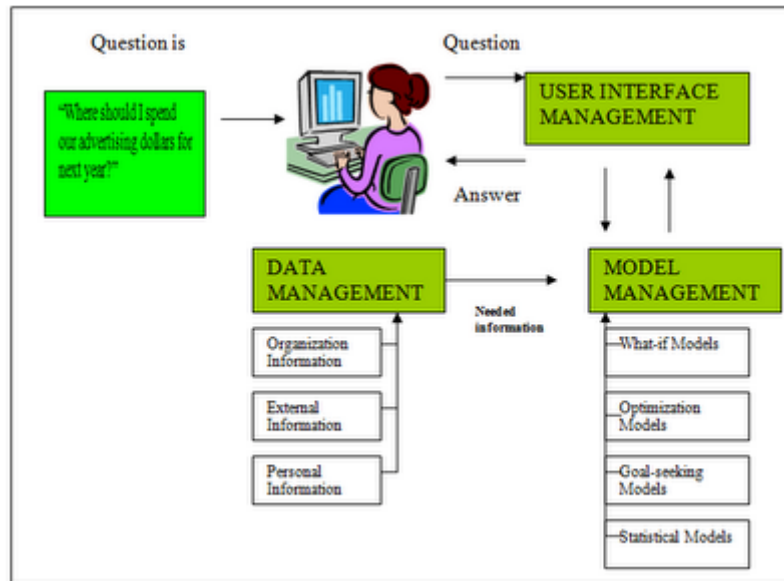

**Decision support systems** vary greatly in application and complexity, but they all share specific features. A typical **Decision support systems** has four components: data management, model management, knowledge management and user interface management.

### Data Management Component

The data management component performs the function of storing and maintaining the information that you want your **Decision Support System** to use. The data management component, therefore, consists of both the Decision Support System information and the Decision Support System database management system. The information you use in your

**Decision Support System** comes from one or more of three sources:

- **Organizational information;** you may want to use virtually any information available in the organization for your Decision Support System. What you use, of course, depends on what you need and whether it is available. You can design your Decision Support System to access this information directly from your company's database and data warehouse. However, specific information is often copied to the Decision Support System database to save time in searching through the organization's database and data warehouses.
- **External information:** some decisions require input from external sources of information. Various branches of federal government, Dow Jones, Compustat data, and the internet, to mention just a few, can provide additional information for the use with a Decision Support System.
- **Personal information:** you can incorporate your own insights and experience your personal information into your Decision Support System. You can design your Decision Support System so that you enter this personal information only as needed, or you can keep the information in a personal database that is accessible by the Decision Support System.

### Model Management Component

**The model management component consists of both the Decision Support System models and the Decision Support System model management system.** A model is a representation of some event, fact, or situation. As it is not always practical, or wise, to experiment with reality, people build models and use them for experimentation. Models can take various forms.



**Businesses use models to represent variables and their relationships.** For example, you would use a statistical model called analysis of variance to determine whether newspaper, TV, and billboard advertising are equally effective in increasing sales.

**Decision Support Systems help in various decision-making situations** by utilizing models that allow you to analyze information in many different ways. The models you use in a Decision Support System depend on the decision you are making and, consequently, the kind of analysis you require. For example, you would use what-if analysis to see what effect the change of one or more variables will have on other variables, or optimization to find the most profitable solution given operating restrictions and limited resources. Spreadsheet software such as excel can be used as a Decision Support System for what-if analysis.

**The model management system stores and maintains the Decision Support System's models.** Its function of managing models is similar to that of a database management system. The model management component can not select the best model for you to use for a particular problem that requires your expertise but it can help you create and manipulate models quickly and easily.

### **User Interface Management Component**

The user interface management component allows you to communicate with the Decision Support System. It consists of the user interface management system. This is the component that allows you to combine your know-how with the storage and processing capabilities of the computer.

The user interface is the part of the system you see through it when enter information, commands, and models. This is the only component of the system with which you have direct contract. If you have a Decision Support System with a poorly designed user interface, if it is too rigid or too cumbersome to use, you simply won't use it no matter what its capabilities. The best user interface uses your terminology and methods and is flexible, consistent, simple, and adaptable.

**For an example of the components of a Decision Support System,** let's consider the Decision Support System that Land's End has tens of millions of names in its customer database. It sells a wide range of women's, men's, and children's clothing, as well various household wares. To match the right customer with the catalog, land's end has identified 20 different specialty target markets. Customers in these target markets receive catalogs of merchandise that they are likely to buy, saving Lands' End the expense of sending catalogs of all products to all 20 million customers. To predict customer demand, lands' end needs to continuously monitor buying trends. And to meet that demand, lands' end must accurately forecast sales levels. To accomplish these goals, it uses a Decision Support System which performs three tasks:

- **Data management:** The Decision Support System stores customer and product information. In addition to this organizational information, Lands' End also needs external information, such as demographic information and industry and style trend information.
- **Model management:** The Decision Support System has to have models to analyze the information. The models create new information that decision makers need to plan product lines and inventory levels. For example, Lands' End uses a statistical model called regression analysis to determine trends in customer buying patterns and forecasting models to predict sales levels.
- **User interface management:** A user interface enables Lands' End decision makers to access information and to specify the models they want to use to create the information they need.

### **Knowledge Management Component**

The knowledge management component, like that in an expert system, provides information about the relationship among data that is too complex for a database to represent. It consists of rules that can constrain possible solution as well as alternative solutions and methods for evaluating them.

**For example,** when analyzing the impact of a price reduction, a Decision Support System should signal if the forecasted volume of activity exceeds the volume that the projected staff can service.



Such signaling requires the Decision Support System to incorporate some rules-of-thumb about an appropriate ratio of staff to sales volume. Such rules-of-thumb, also known as heuristics, make up the knowledge base.

#### 7.12.4 Management Information System

Management Information System is a systematic process of providing relevant information in right time in right format to all levels of users in the organization for effective decision making. MIS is also defined to be system of collection, processing, retrieving and transmission of data to meet the information requirement of different levels of managers in an organization.

##### **According to CIMA-**

MIS is a set of procedures designed to provide managers at different levels in the organization with information for decision making, and for control of those parts of the business for which they are responsible. MIS comprises of three elements viz., management, information and system. The concept of MIS is better understood if each element of the term MIS is defined separately.

**Management:** A manager may be required to perform following activities in an organisation:

- (i) Determination of organisational objectives and developing plans to achieve them.
- (ii) Securing and organising human beings and physical resources so as to achieve the laid down objectives.
- (iii) Exercising adequate controls over the functions performed at the lower level.
- (iv) Monitoring the results to ensure that accomplishments are proceeding according to plans.

Thus, management comprises of the processes or activities that describe what managers do while working in their organisation. They in fact plan, organise, initiate, and control operations. In other words, management refers to a set of functions and processes designed to initiate and co-ordinate group efforts in an organised setting directed towards promotion of certain interests, preserving certain values and pursuing certain goals. It involves mobilisation, combination, allocation and utilisation of physical, human and other needed resources in a judicious manner by employing appropriate skills, approaches and techniques.

**Information:** Information is data that have been organised into a meaningful and useful context. It has been defined by Davis and Olson - "Information is data that has been processed into a form that is meaningful to the recipient and is of real or perceived value in current or progressive decision". For example, data regarding sales by various salesmen can be merged to provide information regarding total sales through sales personnel. This information is of vital importance to a marketing manager who is trying to plan for future sales.

Information is the substance on which business decision are based. Therefore, the quality of information determines the quality of action or decision. The management plays the part of converting the information into action through the familiar process of decision-making. Information has come to occupy a very important position in the survival of a business.

**System:** System may be defined as a composite entity consisting of a number of elements which are interdependent and interacting, operating together for the accomplishment of an objective. One can find many examples of a system. Human body is a system, consisting of various parts such as head, heart, hands, legs and so on. The various body parts are related by means of connecting networks of blood vessels and nerves. This system has a main goal which we may call "living". Thus, a system can be described by specifying its parts, the way in which they are related, and the goals which they are expected to achieve. A business is also a system where economic resources such as people, money, material, machines, etc. are transformed by various organisation processes (such as production, marketing, finance, etc.) into goods and services.



Thus, MIS can be defined as a network of information that supports management decision making. The role of MIS is to recognise information as a resource and then use it for effective and timely achievement of organisational objectives.

### **Potential impact of computers and MIS on different levels of management**

The potential impact of computers on top level management may be quite significant. An important factor which may account for this change is the fast development in the area of computer science. It is believed that in future computers would be able to provide simulation models to assist top management in planning their work activities. For example, with the help of a computer it may be possible in future to develop a financial model by using simulation technique, which will facilitate executives to test the impact of ideas and strategies formulated on future profitability and in determining the needs for funds and physical resources. By carrying sensitivity analysis with the support of computers, it may be possible to study and measure the effect of variation of individual factors to determine final results. Also, the availability of a new class of experts will facilitate effective communication with computers. Such experts may also play a useful role in the development and processing of models. In brief, potential impact of computers would be more in the area of planning and decision making.

Futurists believe that top management will realise the significance of techniques like simulation, sensitivity analysis and management science. The application of these techniques to business problems with the help of computers would generate accurate, reliable, timely and comprehensive information to top management. Such information will be quite useful for the purpose of managerial planning and decision making. Computerised MIS will also influence in the development, evaluation and implementation of a solution to a problem under decision making process.

Potential impact of Computers and MIS on middle management level will also be significant. It will bring a marked change in the process of their decision making. At this level, most of the decisions will be programmed and thus will be made by the computer, thereby drastically reducing the requirement of middle level managers. For example, in the case of inventory control system; computer will carry records of all items in respect of their purchase, issue and balance. The reorder level, reorder quantity etc. for each item of material will also be stored in computer after its predetermination. Under such a system, as soon as the consumption level of a particular item of material will touch reorder level, computer will inform for its purchase immediately. The futurists also foresee the computer and the erosion of middle management as the vehicles for a major shift to recentralisation. The new information technology will enable management to view an operation as a single entity whose effectiveness can only be optimised by making decisions that take into account the entity and not the individual parts.

The impact of Computers and MIS today at supervisory management level is maximum. At this level managers are responsible for routine, day-to-day decisions and activities of the organisation which do not require much judgement and discretion. In a way, supervisory manager's job is directed more towards control functions, which are highly receptive to computerisation. For control, such managers are provided with accurate, timely, comprehensive and suitable reports. A higher percentage of information requirements of executives is met out at this level.

Potential impact of Computers and MIS on supervisory level will completely revolutionise the working at this level. Most of the controls in future will be operated with the help of computers. Even the need of supervisory managers for controlling the operations will be substantially reduced. Most of the operations/activities now performed manually will be either fully or partially automated.

### **Objectives of MIS**

- To provide the managers at all levels with timely and accurate information for control of business activities
- To highlight the critical factors in the operation of the business for appropriate decision making
- To develop a systematic and regular process of communication within the organization on performance in different functional areas

- To use the tools and techniques available under the system for programmed decision making
- To provide best services to customers
- To gain competitive advantage
- To provide information support for business planning for future

**Strategic-level information systems** help senior management to tackle and address strategic issues and long-term trends, both within the firm and external environment. Their principal concern is matching changes in the external environment with existing organisational capability - What will be the cost-trends, where will our firm fit in, what products should be made etc ? In other words, these systems are designed to provide top-management with information that assists them in making long -range planning decisions for the organization.

**Tactical-level information systems** serve middle level managers and help in taking decisions for a period of 2-3 years. The managers are typically concerned with planning, controlling and use summaries of transactions to aid their decision- making. In other words, these systems provide middle-level managers with the information they need to monitor and control operations and to allocate resources more effectively. In tactical systems, transactions data are summarized, aggregated, or analysed. Their purpose is not to support the execution of operational tasks but to help the manager control these operations.

**Operational-level information systems** are typically transaction processing systems and help in the operational level managers to keep track of elementary activities and transactions of the organisations such as sales, receipts, cash deposits, flow of materials etc. Their purpose is to answer routine questions and to track flow of transactions. Thus, the primary concern of these systems is to collect, validate, and record transactional data describing the acquisition or disbursement of corporate resources.

Thus, each type of information system serves the requirements of a particular level in the organisation, providing the needed basis for decision making.

### 7.12.5 On-Line Analytical Processing (OLAP)

On-Line Analytical Processing (OLAP) is a category of software technology that enables analysts, managers and executives to gain insight into data through fast, consistent, interactive access to a wide variety of possible views of information that has been transformed from raw data to reflect the real dimensionality of the enterprise as understood by the user.

OLAP functionality is characterized by dynamic multi-dimensional analysis of consolidated enterprise data supporting end user analytical and navigational activities including:

- calculations and modeling applied across dimensions, through hierarchies and/or across members
- trend analysis over sequential time periods
- slicing subsets for on-screen viewing
- drill-down to deeper levels of consolidation
- reach-through to underlying detail data
- rotation to new dimensional comparisons in the viewing area

OLAP is implemented in a multi-user client/server mode and offers consistently rapid response to queries, regardless of database size and complexity. OLAP helps the user synthesize enterprise information through comparative, personalized viewing, as well as through analysis of historical and projected data in various "what-if" data model scenarios. This is achieved through use of an OLAP Server.



## OLAP Server

An OLAP server is a high-capacity, multi-user data manipulation engine specifically designed to support and operate on multi-dimensional data structures. A multi-dimensional structure is arranged so that every data item is located and accessed based on the intersection of the dimension members which define that item. The design of the server and the structure of the data are optimized for rapid ad-hoc information retrieval in any orientation, as well as for fast, flexible calculation and transformation of raw data based on formulaic relationships. The OLAP Server may either physically stage the processed multi-dimensional information to deliver consistent and rapid response times to end users, or it may populate its data structures in real-time from relational or other databases, or offer a choice of both. Given the current state of technology and the end user requirement for consistent and rapid response times, staging the multi-dimensional data in the OLAP Server is often the preferred method.

Executives of business have to make crucial decision for the future of their enterprise. The plethora of business data (customers, products, etc) lead us to store them in a place and then to retrieve the suitable information according to some rules. Databases solved one part of the problem that is the data storage. To retrieve the appropriate information from the business data a variety of tools, using different techniques, exist that performs simple or complex tasks involving mathematical and statistical operations. These tools are lying under the notion of Decision Support Systems (DSS) technology.

The core of any OLAP system is an OLAP cube (also called a 'multidimensional cube' or a hypercube). It consists of numeric facts called measures which are categorized by dimensions. The measures are placed at the intersections of the hypercube, which is spanned by the dimensions as a Vector space. *The usual interface to manipulate an OLAP cube is a matrix interface like Pivot tables in a spreadsheet program, which performs projection operations along the dimensions, such as aggregation or averaging.*

*The cube metadata is typically created from a star schema or snowflake schema of tables in a relational database. Measures are derived from the records in the fact table and dimensions are derived from the dimension tables.*

*Each measure can be thought of as having a set of labels, or meta-data associated with it. A dimension is what describes these labels; it provides information about the measure.*

*A simple example would be a cube that contains a store's sales as a measure, and Date/Time as a dimension. Each Sale has a Date/Time label that describes more about that sale.*

*Any number of dimensions can be added to the structure such as Store, Cashier, or Customer by adding a foreign key column to the fact table. This allows an analyst to view the measures along any combination of the dimensions.*

### Multidimensional databases

*Multidimensional structure is defined as "a variation of the relational model that uses multidimensional structures to organize data and express the relationships between data". The structure is broken into cubes and the cubes are able to store and access data within the confines of each cube. "Each cell within a multidimensional structure contains aggregated data related to elements along each of its dimensions". Even when data is manipulated it remains easy to access and continues to constitute a compact database format. The data still remains interrelated. Multidimensional structure is quite popular for analytical databases that use online analytical processing (OLAP) applications (O'Brien & Marakas, 2009). Analytical databases use these databases because of their ability to deliver answers to complex business queries swiftly. Data can be viewed from different angles, which gives a broader perspective of a problem unlike other models.*

### Aggregations

*It has been claimed that for complex queries OLAP cubes can produce an answer in around 0.1% of the time required for the same query on OLTP relational data. The most important mechanism in OLAP*

which allows it to achieve such performance is the use of *aggregations*. Aggregations are built from the fact table by changing the granularity on specific dimensions and aggregating up data along these dimensions. The number of possible aggregations is determined by every possible combination of dimension granularities.

The combination of all possible aggregations and the base data contains the answers to every query which can be answered from the data.

Because usually there are many aggregations that can be calculated, often only a predetermined number are fully calculated; the remainder are solved on demand. The problem of deciding which aggregations (views) to calculate is known as the view selection problem. View selection can be constrained by the total size of the selected set of aggregations, the time to update them from changes in the base data, or both. The objective of view selection is typically to minimize the average time to answer OLAP queries, although some studies also minimize the update time. View selection is NP-Complete. Many approaches to the problem have been explored, including greedy algorithms, randomized search, genetic algorithms and A\* search algorithm.

### Types

OLAP systems have been traditionally categorized using the following taxonomy.

#### Multidimensional

MOLAP is a “multi-dimensional online analytical processing”. ‘MOLAP’ is the ‘classic’ form of OLAP and is sometimes referred to as just OLAP. MOLAP stores this data in an optimized multi-dimensional array storage, rather than in a relational database. Therefore it requires the pre-computation and storage of information in the cube - the operation known as processing. MOLAP tools generally utilize a pre-calculated data set referred to as a data cube. The data cube contains all the possible answers to a given range of questions. MOLAP tools have a very fast response time and the ability to quickly write back data into the data set.

#### Relational

**ROLAP** works directly with relational databases. The base data and the dimension tables are stored as relational tables and new tables are created to hold the aggregated information. Depends on a specialized schema design. This methodology relies on manipulating the data stored in the relational database to give the appearance of traditional OLAP's slicing and dicing functionality. In essence, each action of slicing and dicing is equivalent to adding a “WHERE” clause in the SQL statement. ROLAP tools do not use pre-calculated data cubes but instead pose the query to the standard relational database and its tables in order to bring back the data required to answer the question. ROLAP tools feature the ability to ask any question because the methodology does not limit to the contents of a cube. ROLAP also has the ability to drill down to the lowest level of detail in the database.

#### Hybrid

There is no clear agreement across the industry as to what constitutes “Hybrid OLAP”, except that a database will divide data between relational and specialized storage. For example, for some vendors, a HOLAP database will use relational tables to hold the larger quantities of detailed data, and use specialized storage for at least some aspects of the smaller quantities of more-aggregate or less-detailed data. HOLAP addresses the shortcomings of MOLAP and ROLAP by combining the capabilities of both approaches. HOLAP tools can utilize both pre-calculated cubes and relational data sources.

#### Comparison

Each type has certain benefits, although there is disagreement about the specifics of the benefits between providers.

- Some MOLAP implementations are prone to database explosion, a phenomenon causing vast amounts of storage space to be used by MOLAP databases when certain common conditions are met: high number of dimensions, pre-calculated results and sparse multidimensional data.

- MOLAP generally delivers better performance due to specialized indexing and storage optimizations. MOLAP also needs less storage space compared to ROLAP because the specialized storage typically includes compression techniques.[15]
- ROLAP is generally more scalable.[15] However, large volume pre-processing is difficult to implement efficiently so it is frequently skipped. ROLAP query performance can therefore suffer tremendously.
- Since ROLAP relies more on the database to perform calculations, it has more limitations in the specialized functions it can use.
- HOLAP encompasses a range of solutions that attempt to mix the best of ROLAP and MOLAP. It can generally pre-process swiftly, scale well, and offer good function support.

### Other types

The following acronyms are also sometimes used, although they are not as widespread as the ones above:

- **WOLAP** - Web-based OLAP
- **DOLAP** - Desktop OLAP
- **RTOLAP** - Real-Time OLAP

### Appendix: Econometrics Basic Concepts

#### Endogenous Variable and Exogenous Variable

They are the observable variables and usually there are more variables than the number of equations in the model. Some of the variables are supposed to be determined by forces completely outside the model and their values are assumed to be given. Such variables are called "Exogenous Variables". Variables like "government policy, population etc. are the example of exogenous variables. It is treated like a parameter in solving the equations of a model.

The variable whose values are determined by the system when parameters disturbances and exogenous variables are given are called " Endogenous Variables". Endogenous variables cannot affect the value of exogenous variables. But the values of exogenous variables influence the value of endogenous variables.

#### Type 1 Error

The decision to accept or reject the null hypothesis  $H_0$  is made on the basis of information supplied by the sample observations. It is possible the conclusion drawn on the basis of a particular sample may not be true in aspect of population. When the test procedure rejects a hypothesis when it ought to have been accepted, it is called "type 1 error".

#### Null Hypothesis

It implies a neutral or non-committal attitude of the statistician in testing the hypothesis. It is a hypothesis of absence of relationship or absence of difference between sample static and population parameters.

$\beta_0 = 0$  is the null hypothesis.

#### Level of Significance

The validity of a hypothesis  $H_0$  is against the alternative hypothesis  $H_1$  is tested at a certain level. The Level of Significance determines the confidence within which a statistician accepts a null hypothesis. 5% is the level of significance and 95% is the level of confidence.

### **$R^2$ (R Square) and $\bar{R}^2$ ( R Bar Square)**

R Square is the Measure of “ Goodness Of Fit: It Measures How Well the Regression Line Fits the Observed Data.  $R^2$  Lies Between 0 And 1

i.e.  $0 < R^2 < 1$

When There is Inclusion of Additional Explanatory Variables in the Function it can Never Reduce  $R^2$  and will Usually Increase it. To Correct for this Defect, we Adjust  $R^2$  by taking into Account the Degree of Freedom, which Clearly Decrease as New Independent Variable, Known as (R Bar Square). It is also known as “ Loss of Degree of Freedom”.

### **Type 2 Error**

When the test leads to acceptance of a false hypothesis, it is called type 2 error.

### **Critical Region**

While Accepting or Rejecting a Null Hypothesis at a Given Level of Significance the Region of Rejection is called as Critical Region Whereas the Other Region is Called as Region of Acceptance.

### **Problem of Identification**

Problem of Identification implies out whether Numerical Estimates of the Parameters of the structural Equation can be Obtained from the Estimated Reduced form of Coefficient. If This is possible then we say that the equation is Identified. Identification Problem arise only for those Equations, which have coefficients which have to be Estimated Statistically.

### **Order Condition and Rank Condition**

**Order Condition:** For an Equation to be Identified the Total No. of Variables Excluded from it but included in other Equations of the Model Must be atleast as Great as the no of Equations of the System Minus One.

**Rank Condition:** In a System of G Equations any Particular Equation is Identified if and only if it is possible to Construct atleast one Non-Zero Determinant of Order (G-1) from the Co-Efficient of the Variables Excluded from that Particular Equation but Contained in the other Equations of the Model.

### **Structural form and Reduced form of Simultaneous Equation Model**

The equations appearing in a simultaneous equation model are called structural or behavioral equations. They describe the structure or behaviour of the economy or a producing firm in an econometric model. The parameters of these equations are called “structural parameters”. The number of such equations in a model is equal to the no. of endogenous or jointly dependent variables.

Reduced form equations are those equations, which express the endogenous variables only in terms of the predetermined variables and the stochastic disturbances. Reduced form equations can be obtained in 2 ways -

1. Express the endogenous variables directly as functions of the predetermined variables.
2. solve the structural system of endogenous variables in terms of predetermined variables, the structural parameters and disturbances.



## ADDITIONAL MATERIAL FOR REFERENCE

### TOTAL QUALITY MANAGEMENT (TQM) & TATA BUSINESS EXCELLENCE MODEL (TBEM)

Words such as 'quality' and 'business excellence' have become so much a part of the management lexicon that they are sometimes taken for granted, observed more in the breach or by faddish rote. Not so in the Tata Group, where they have been embraced with a passion that reflects a deeper understanding of their significance to the health and wealth of all entrepreneurial activity.

The quality movement in the Tata Group is defined by a framework known as the Tata Business Excellence Model (TBEM), which has been adapted from the renowned Malcolm Baldrige archetype. The Model works under the aegis of Tata Quality Management Services (TQMS), an in-house organisation mandated to help different Tata companies achieve their business objectives through specific processes. These processes — which have come to characterise the Tata way of enhancing and conducting its business endeavours — essentially relate to two factors: business excellence and business ethics.

TQMS plays the role of supporter and facilitator in the journey that Tata enterprises undertake to reach the peaks of business eminence while, at the same time, adhering to the highest ethical standards. There are, primarily, two tools that define the pathways and scope of this journey. The first of these is TBEM and the other is the Tata code of conduct.

While quality has always been one of the cornerstones of the Tata way of business, the need to introduce a formal system that calibrated how different group companies were faring on this scale began being felt in the early 1990s. That led to the institution, in 1995, of the JRD Quality Value Awards, the forerunner to TBEM. Named after JRD Tata, the late chairman of the group and a crusader for the cause of business excellence in Tata companies, the awards have now been incorporated in TBEM. Companies taking the TBEM road vie for gold and silver every year, and the winners are presented the honours on July 29, JRD's birth anniversary.

Speaking at the 2001 edition of the JRD QV Awards, Group chairman Ratan Tata touched on the TBEM imperative. "Without being critical, it is true that many of our companies had their heads in the sand and were resting on past glories," he said. "In the course of time, the view gained ground that we were less nimble than others, more resistant to change and more set in our ways. What we needed to do, of course, was benchmark ourselves against the best, get away from doing things the way we were, and put certain processes in place.

"Instead of just putting together an award with a cursory kind of assessment process, we thought out a robust and comprehensive process which I think we are all benefiting from now. This process has, in fact, set the tone and laid the foundation for what I believe is one of the important changes we have made in the group over the last five years." In the years since Mr Tata made these points, the call of quality has resonated across the group in even stronger fashion.

A basic building block of the quality movement in the group is the corporate governance doctrine of every Tata company and their overall philosophy, which has been articulated through the term 'Leadership with Trust'. There is a formal arrangement that governs the relationship between individual Tata companies and the superstructure that is the Tata Group. In order to use the Tata nomenclature, a group company has to sign a contract called the Brand Equity and Business Promotion (BEBP) Agreement. This places an obligation on the company signing on to adopt TBEM as a means to attaining business leadership.

The TBEM methodology has been moulded to deliver strategic direction and drive business improvement. It contains elements that enable companies following its directives to capture the best of global business processes and practices. The model has retained its relevance thanks to the dynamism built into its core. This translates into an ability to evolve and stay in step with ever-changing business performance parameters.

TQMS helps Tata companies gain insights on their strengths and their opportunities for improvement. This is managed through an annual process of 'applications and assessments'. Each company writes



an application wherein it describes, in the context of the TBEM matrix, what it does and how it does it. This submission is then gauged by trained assessors, who study the application, visit the company and interact with its people. The assessors map out the strengths and improvement opportunities existing in the company before providing their feedback to its leadership team.

TQMS trains and certifies assessors, who are selected from across the group, and it designs and administers an assessment apparatus that helps them evaluate different Tata companies. The point person in each company is the 'corporate quality head', nominated by the CEO as the business excellence process owner. Typically, each company has a network of business excellence people from a variety of functions and locations.

The commitment a company makes when it signs the BEBP contract compels it to attain explicit business excellence scores over specific time periods. A result-driven scoring mechanism enables the company to track its progress over time, and ensure that it keeps improving. There is also an annually administered, group-wide recognition system for companies that exceed a certain score, thereby reflecting excellence, industry leadership and consistent improvement.

TQMS also has an 'assurance module' that captures how executives perceive their own company's progress on the TBEM chart. This module provides objective feedback to the management of each organisation as well as the Tata Group Corporate Centre on the perceptions of company insiders on the progress made in business ethics and business excellence.

The TQMS surveys explore whether a structure is in place in the company, whether processes are deployed, whether senior, middle and junior management are personally involved in leading and supporting the processes, whether change and improvement initiatives are vibrant, and whether planning and review mechanisms are being used by the leadership to stimulate continuous advancement.

Implicit in the TQMS approach is the belief that its wide-ranging methodology will enable Tata companies to become exemplars - on business as well as ethical parameters — in their respective spheres.

The TBEM matrix is used for the organisational self-assessment of Tata companies, recognition and awards, and for providing feedback to applicants. In addition, TBEM plays three important supportive roles in strengthening the competitiveness of Tata companies:

- It helps improve business excellence practices, capabilities and results.
- It facilitates communication and sharing of best practices among Tata companies.
- It serves as a working tool for understanding and managing performance, for providing planning guidance, and for identifying learning opportunities.

The TBEM methodology comprises a set of questions that applicant Tata companies have to answer. Its main objectives are to enhance value to customers and contribute to marketplace success; maximise enterprise-wide effectiveness and capabilities; and deliver organisational and personal learning. The methodology is built on the following set of interrelated core values and concepts: visionary leadership; customer-driven excellence; organisational and personal learning; valuing of employees and partners; agility; future focus; managing for innovation; management by fact; social responsibility; results and value creation; and systems perspective.

The core values and concepts of TBEM are embodied in seven categories: Leadership; strategic planning; customer and market focus; measurement, analysis and knowledge management; human resource focus; process management; and business results. The TBEM system focuses on certain key areas of business performance: customer-focused results; product and service results; financial and market results; human resource results; organisational effectiveness results; governance and social responsibility results.

The set of questions to be addressed by an applicant for TBEM-based assessment comprises result-oriented requirements. However, TBEM does not offer any prescriptions, and with good reason. The



focus is on results, not on procedures, tools or organisational structures. Companies are encouraged to develop and demonstrate creative, adaptive and flexible approaches for meeting basic requirements.

In the same speech quoted earlier, Mr Tata also said: “When we started [the TBEM] process, some of us, and certainly I, felt frustrated because I sensed a great deal of cynicism among many people who thought all this was unnecessary, that it was just a fad.” Time — and TBEM — has proven how much attitudes have changed, and how far down the road Tata companies following the methodology have come.

## **1. INTRODUCTION**

Many Indian Auto companies in India have been doing exceptionally well since early 1990's by learning from each other and following the philosophy of Total Quality Management (TQM) as a way for their corporate strategy to achieve Business Excellence. Many Indian companies especially in the automobile-component sector have been applying the principles of TQM or Business Excellence for competing in this very competitive market. With help from Prof. Osada of Japanese Union of Scientist and Engineers (JUSE) and the Confederation of Indian Industry (CII), these companies have been applying the Deming Model for TQM Implementation in their companies for achieving competitive advantage.

Many of the companies like Sundaram Clayton, Sundram -Brakelining, Sundaram Fasteners, TVS Lucas of the TVS group and Sona Koyo Steering Limited have been applying the principles of TQM and Business Excellence by applying the Guidelines for the Deming Prize instituted by the Japanese Union of Scientists and Engineers (JUSE).

### **1.1 The Deming Prize (Japanese Model for Excellence)**

This best known prize with the longest history was first awarded by the Japanese Union of Scientist and Engineers (JVSE) in 1951 to a Japanese company which excelled in Total Quality Management. This prize is given for an overall performance of a company. Till 1991 this prize was given to only Japanese Companies but from 1992, any company outside Japan could apply for Japanese--Deming Prize.

### **1.2 The 10-Point Content of the Deming Prize Comprehensively Covers Issues for Any Organization as Given below:**

1. Policy
2. Organization
3. Information
4. Standardization
5. Human Resource Development and Utilization
6. Quality Assurance Activities
7. Maintenance and Control Activities
8. Improvement Activities
9. Effects including Tangible and Intangible effects, Methods for measuring and grasping effects, customer satisfaction and employee satisfaction, Influence on associated companies and local and international communities.
10. Future Plans for the organization for improving problems, changes in social and customer environment and future plans, relationship between management philosophy, vision and long term plans.

## 2. STRATEGIC MANAGEMENT BY BUSINESS POLICY (SMBP) FOR TQM IMPLEMENTATION

Prof. Osada, the Japanese Guru for JUSE emphasizes the concept of Strategic Management by Business Policy (SMBP) for TQM Implementation.

Excellent companies in 21st century will have to focus on

### (a) Sustainable growth

Looking at all stakeholders' satisfaction, which implies value for customer, employee, society, business partner and shareholders and be

### (b) Able to face the mega competition and win the competitive advantage by

- Differentiation strategies
- Tapping of creativity and innovation from all its employees for coming out with creative and innovative products.
- And having optimum resource allocation.

View points needed for strategic planning, as per Osada should certain the following:

- (a) Innovation: strategic & future orientation
- (b) Improvement in processes: problem solving
- (c) Forecasting business environment clearly & comprehensively
- (d) Product business lifecycle
- (e) Positioning, benchmarking
- (f) And focus on optimum resource allocation
- (g) Concentrate on key success factors / failure factors
- (h) Practical strategy looking at product, market & strategic elements
- (i) Participatory type of strategic planning
- (j) And finally strategic planning implementation.

By applying this framework and the concerns for the Deming prize, companies in the TVS Group like, Sundram Clayton, Sundram Brakelining, TVS Motors, have achieved excellence. Other auto- component manufacturers like Jay Bharat Maruti, a subsidiary of Maruti Udyog Limited, Sona Koyo Steering, and Minda Huf Ltd. in India have established a level of excellence by which they are able to supply their products to the top automobile manufactures of the world based in India. They are also able to export to foreign countries facing the challenges of global competition successfully. Two examples of Indian auto component companies would be highlighted in the next part of the paper:

## 3. CASE STUDIES FOR DEMING PRIZE WINNERS IN AUTO-COMPONENT COMPANIES

### A) Sona Koyo Steering Systems Ltd., India

In Jan. 1985, Sona Group had technical collaboration agreement with Koyo Seiko Co. Ltd., Japan for manufacture of manual steering, gear assemblies and steering column assemblies. From October 1987 this company started its production. In 1992 equity participation of 8% by Koyo and it was increased to equity participation to 20.5%. In 1998, Sona Steering systems changed to Sona Koyo Steering Systems Ltd. Since 1994 Koyo certified Sona as an approved vendor for export of steering parts to Japan.

Policy management is the process of formulating, deploying and implementing the company policy of the year related to high priority to lower levels in the organization. Policy Deployment starts from the Top Management and goes down to Plant Manager, Departmental Manager and to the Section Manager level. The process has been improved over the years based on the learning during implementation using the Plan, Do, Check, Act (PDCA) Cycle as propagated by Guru's like Shewart and Deming.



Implementation of Objectives & Action Plans at Sona Koyo Steering Systems Ltd. the implementation of objectives and action plans is briefly highlighted as:

- Weekly review of action plan in Managing Committee meetings
- Monthly review of Divisional Objectives
- Quarterly review of Chief Level Objectives
- Half yearly review of Company Objectives
- Daily, weekly and monthly gap analysis of Checking Points, and
- Monthly review of Managing Points

This has given better results in terms of reducing the manufacturing expenses as % of net sales from 2000 year onwards. Fuel consumption per unit of power has gone down since year 2000.

Inventory Turnover ratio has improved; In-house rejection have declined customer returns Per Part Million (PPM) has decreased since year 2000. After implementing the concept of policy management in the company. Some highlights of the company from the primary source are given which gives us an idea how this company has achieved competitive advantage in the field of auto component business.

New competitions will be coming through supplier power and price level sensitivity in the market. New opportunity for the company will be in Western Europe and North America as well as new challenges in Indian market.

Some of the aspect of the competitive advantage in this company is:

- Shared costs between several products
- Quality & knowledge of work force
- Experience and knowledge of business & organizational learning culture
- Production technology upgradation
- Strategic outsourcing
- Standardization of product and pricing policy
- Good relationship with suppliers computerized management of information flows and material flows
- Good policy management systems in the company

New strategic goals of the company are:

- Development of new knowledge and technologies
- Increase of the sales turnover
- To be present in the global market
- Research and development reinforcement & development of unique capabilities within the company for innovation

The company won the prestigious Deming Application Prize for Business Excellence awarded by Japanese Union of Scientists and Engineers (JUSE) in 2003. This company has become globally competitive by applying the principles of Total Quality and Excellence.

B) Sundaram--Clayton Limited Brakes Division (Chennai), India This Company was established in 1962 as a joint venture with Clayton Devandre, UK (Now WABCO Automotive UK). WABCO Automotive is part of American Standard Inc.--a fortune 500 company. Sundaram Clayton--Brakes Division is located at Chennai and is part of the TVS group, which was established in India in 1911.

### **SCL Products:**

- Air brake systems for medium and heavy commercial vehicles
- Vacuum brake products for light commercial vehicles.
- Anti-lock braking systems (ABS) and Anti-spin Regulation Systems.

In 1983-87 there was a recession in the Automobile Industry and Emergence of Competition in Sundaram Clayton Business. There was a drop in market share and profitability. Thus in 1987-88 there was a wakeup call for the company to gear up and faced competition. Sundaram Clayton embraced the TQM philosophy and the Deming model for improving performance and manufacturing excellence.

### **1987-90 phase the Introduction phase**

The first issues was to be tackled in this phase was bringing about a cultural change in the organization by having common uniform for all employees, open offices, total employee involvement, where quality circles and suggestion schemes were encouraged among the employees.

Restructuring Manufacturing process was done to have product layout, self-contained units, and operator's ownership of Quality.

### **1990-1994: The Promotion phase**

The Policy Management philosophy was employed to have goal congruence among all the levels of management. Measures and targets were fixed and monitored / reviewed and achieved. The audit reviews were carried out throughout the organization.

The concept of cellular manufacturing--emphasizing Productivity Improvements, Lead--Time Reduction, settings up of operation standards for all key processes were done.

Massive efforts towards Education and Training where problem solving skills were imparted to company wide employers at all levels.

### **1994-1998: Deployment Phase**

Standardization was adopted for all processes and operating procedures were written for every activity specially all manufacturing activity & related activities. Poka-Yoke (Mistake Proofing) was implemented for various machines in the manufacturing process.

New Product Development was taken up very seriously applying a multidisciplinary task force full time and New Product Development (NPD) process was well defined and all the tools and techniques were applied for New Product Development.

Supplier Development was emphasized for the whole manufacturing function. Manufacturing cells were created at the suppliers' sites and training of suppliers or vendors of the company was done by the specialists.

In 1998 Sundaram Clayton--Brakes Division was awarded "Deming Application Prize" for distinctive performance improvement through the application of Company-wide Quality Control. This company became the fourth company outside Japan and the very first in India to receive this prestigious award.

### **Continuos Improvement phase (1998--Present)**

Responding to the External changes and the Internal changes, the Deming examiner's feedback with TVS corporate values in mind, efforts began to own new products, sustain product quality and productivity with social responsibility for improved customer satisfaction and business results.

Concepts like Total Productivity Maintenance (TPM), Lean Manufacturing, Application of IT as enabling processes Productivity Improvement, Establishing Environmental Management Standards (EMS) as per ISO 14001 standard were taken up. Development work for electronic control system for air brakes was taken up during this period. Development of new customers has also being given importance. For



sustaining profit, product mix optimization and cost management have been made very effective throughout the company. The Road map for competitiveness as applied by SCL.

With the above two case study, from the auto component industry in India, we have seen how policy management as part of the Deming way of implementing Total Quality Management (TQM) for achieving business excellence has been implemented in the two case studies.

#### **4. TATA BUSINESS EXCELLENCE MODEL (TBEM) AT TATA STEEL:**

Now we look at the genesis of the Tata Business Excellence Model (TBEM) applied by one of the largest diversified and admired private group in India the Tata Group. Based on the American Model, The Malcolm Baldrige Award for business Excellence, The TBEM is applied in one of the oldest companies of the group, Tata Steel, the first Steel Company in Asia, which started in 1907 in India. By applying this integrated model for excellence, has become one of the best steel companies of the world now.

Tata Business Excellence Model at Tata Steel: One of the largest business groups in India consists of 85 companies and 7 business sectors worth about ₹ 50, 000 crores i.e. about US \$11. 213 billion in revenues. Tata Group of companies have taken upon themselves one of the largest strategic change initiatives in their companies through the Tata Business Excellence Model (TBEM) launched in 1998 to grapple with the challenges and transformation, the competitive environment was throwing upon the different companies in the Group. Post 1991--when the liberalization era had just begun in India, there was a change in the competitive scenario in India and companies had to adopt their strategies and philosophies which would make them more competitive in the market place.

Between December 1998 and early 2000, about 30 companies in the Tata Group signed up to implement the Tata Business Excellence Model (TBEM) and from July 2000, these companies are being annually evaluated on the 7 criteria that constitute the TBEM:

1. Leadership
2. Strategic Planning
3. Customer and Market Focus
4. Information and Analysis
5. Human Resource Management
6. Process Management and
7. Business Results

#### **Origin of TBEM:**

The genesis of the Tata Business Excellence Model (TBEM) lies in the JRD Quality Value (JRDQV) Award launched after the death of the group chairman Mr. J.R.D. Tata in 1994 in his memory for the Tata group companies. This model is based on Malcolm Baldrige National Quality Award that jump-started the Quality movement in USA in 1988. The TBEM, which was adopted in Tata Group, companies including Tata Steel, was adopted in 1998. It has all the same criteria as the Malcolm Baldrige Award criteria plus it also incorporates the Tata Brand equity promotion and Tata Code of conduct.

#### **JRDQV Award Quest at Tata Steel:**

Tata Steel, the oldest Integrated Steel Company India, which was, founded in 1907 at Jamshedpur in the Bihar State (Now called Jharkhand State) produces about 3 Million Tons/year of saleable steel. Tata Steel is Asia's first and country's largest private sector integrated steel plant. The company has played a pioneering role in integrating professional business practices with exemplary corporate citizenship programs in India. In mid of year 2000, the company has started operating a 1 Million-Ton Cold Rolling Plant with the collaboration with Nippon Steel, Japan. In 1999-2000, the company had a sales turnover of ₹ 6,943.33 Crores i.e. about \$1.47 Billion and Profit after Taxes as ₹ 422.59 Crores i.e. about \$8.93 Million. In the year 2000-2001, the sales turnover was ₹ 7814.58 Crores i.e. about \$1.65 Billion with a net

profit of ₹ 553.44 Crores i.e. \$11.71 Million. Year 2001-2002 was a very difficult year for the steel industry. All the companies in the world made losses but Tata Steel made a profit of ₹ 205 crores and in 2002-2003, The company has done exceedingly well by making a net profit of ₹ 1012 crores i.e. about \$18.72 Million. Tata Steel in its new vision statement in 1998 had taken up the challenge to become the lowest cost producer of steel in the world. Till the year 2000, it was second to the leading Korean Steel Company, Posco Steel.

In year 2001-2002 as per the World Steel Dynamics, Tata Steel of India has become the lowest cost producer of steel in the whole world.

This is the only company among the Tata Group, which has crossed 600 points out of 1000 points to qualify for the JRDQV award in July 2000. Tata Steel is way ahead of the other companies because it's quest for Total Quality and Excellence, which started in the late 1989, when it started its Total Quality Management (TQM) movement. In early 1992, it adopted the Malcolm Baldrige Award Criteria for implementing TQM in various divisions of the company and called it the JN Tata Quality Award, where various divisions within the company were competing with each other on Total Quality Implementation. In 1994, Tata Steel adopted the JRDQV guidelines again based on Malcolm Baldrige guidelines for moving towards Total Quality or Business Excellence, and started competing with other Tata group companies. From 1998 onwards it has been leading in the JRDQV award total scores in the Tata group. The need for TBEM and what it does are given in the next sections.

#### **The Need for the TBEM:**

The following issues were considered before the Tata Group felt the need for adopting the Tata Business Excellence Model (TBEM). They are:

- Processes and practices were not customer-centric in the companies
- Tata Group Companies pursued size instead of agility
- Performance standards varied between organizations
- Knowledge and best practices were not being shared
- There was no unified management strategy for the Tata Group

#### **What the TBEM Does?**

- Provides a framework for the group to become competitive
- Uses quality as the route to acquiring competitiveness
- Works as a competition to ensure participation
- Becomes a transformational tool for every company

#### **The TBEM Model:**

Beyond the broad guidelines, the model has no prescriptions, and is extensively adaptable. The choices of the tools of implementation lie entirely with the company, as does the method of deployment. Here is how the TBEM drives excellence across functions:

- The leadership criteria checks how senior leaders create a leadership system based on Group Values
- The customer and Market Focus checks how the company determines customer groups, key customer needs, and complaint-management issues
- The Strategic Planning criteria examines how the company develops strategic-objectives, action plans and resource allocation
- Analysis criteria check whether the organization has key metrics in place to measure and



- The human resources management checks the appraisal-system, the work environment, and the training and development of employees
- The process management examines the product-design, production and delivery process and supply-chain management
- The business results criteria measures the organization's performance in business areas like customer satisfaction, human resource results and company's financial results.

The inter-linkages between the different criteria for the model on the above points as given in the JRDQV Model, based on American Model Malcolm Baldrige Model for Business Excellence.

The foundation on which the Tata Business Excellence Model (TBEM) is built upon is the 1) JRDQV Award guidelines (based on Malcolm Baldrige Quality Award), which emphasizes on quality practices, customer focus and process improvement and 2) the Tata Brand Equity Business Promotion (BEBP) which lays down the criteria for using the Tata Brand and 3) the code of conduct for the Tata group and ethical practices for the Tata Group.

Beyond the broad guidelines, the model has no prescriptions and is extremely adaptable. The choices of tools of implementation lie entirely with the company, as does the method of deployment. TBEM drives excellence across functions. Every group company with different business is applying this model for business excellence in their own way.

Massive education and training effort is in place in the company to take care of the minimum training needs for each employee and the developmental need for every employee. This is achieved through in-house Management Development Center and Technical Training Institute for the company. Every Department in the company has Training and Educational Executive and coordinates the Education and Training function with the central company facilities. The Human Resource Division has now an organizational learning wing, which caters to the employee's learning needs. When Tata Steel won the JRDQV awards in July 2000, its highest scores were in the category of "Customer and Market-Knowledge" and Public Responsibility and Citizenship" Now, Knowledge Management structures has been created for the benefit of integration of knowledge within the company. The measures based on Customer, In-process, Financial and Innovation and Learning are monitored at the top management level. It also percolates to each department and division and individual employee. Tata Steel started positioning itself as a more competitive and customer-oriented steel manufacturer. For this, a process was needed which could be used by the managers throughout the organization to improve their performance and hence the competitiveness of the organization. In order to achieve such a goal, the company incorporated Benchmarking into its corporate strategy and started Reengineering its core Business processes.

### **Journey for Business Excellence at Tata Steel**

Prior to globalization of Indian economy in 1991, the competition in steel industry was limited. By adopting measures leading to marginal improvements, Tara Steel was ahead of its Indian competitors. However, the company was primarily inward looking and was not affected much with the happenings beyond Indian economy with globalization, the environment changed dramatically and the company had to think 'out of the box'. It became necessary to redefine the business elements (technology, products, market-segment, human resource, input materials, plant location, etc.), business priorities, vision, strategies, management tool and techniques etc. In effect, the company redefined and reoriented itself in a turbulent environment. First adopting the Total Quality Management (TQM) philosophy as a part of Competitive Strategy was formally launched in the company in late 1989. It started with massive effort on education and training on TQM. It started with ISO 9001 and ISO 9002 certification of various manufacturing and later service units. Process Improvements through Quality Improvement Projects (QIP's), Value Engineering Projects and Statistical Process Control projects and Operations Research Projects by managerial teams was making great contributions in various departments and divisions of the company. Quality Circles and 5S as strategic tool for employee involvement and improvement were adopted in all departments of the company. It adopted the J N Tata Quality Award Model based



on Malcolm Baldrige Model for its various divisions in the company in 1992. Later it adopted the JRDQV Model for Business Excellence in 1994 for competing with other group companies. Benchmarking and Business Process Reengineering (BPR) emerged as powerful Management Tools in this direction complimenting the TQM efforts at Tata Steel in terms of continuous improvement in process and practices. Concept of Balanced Score Card was integrated with the TQM strategy of the company in 1998. It was integrated with the Annual quality Improvement Plans (AQUIP's) of various departments.

#### **New thrust areas at Tata Steel:**

In the quest for further increasing their benchmark and improving their processes, Tata Steel has signed an Automotive Steel Technology Cooperation with Nippon Steel of Japan and Arcelor of Europe. This will help Tata Steel get the technology of making high quality sheets for the Indian automotive market. The top management of Tata Steel has created the new vision 2007 after Tata Steel became the world's lowest cost producer of hot-rolled coils at \$160 per tonne in the year 2001.

#### **The new vision 2007**

"To seize the opportunities of tomorrow and create a future that will make us an EVA +ve company. To continue to improve the quality of life of our employees and communities we serve"

This vision will uphold the spirit and values of the Tata's towards nation building. It will realize the core business for a sustainable future and venture into new business that will own a share of the company's future. Applying and adopting the strategic issues as discussed in this paper, Tata Steel, has been able to achieve the JRDQV Award in July 2000. This is the only company among the Tata Group of companies to have got this award for excellence based on the Malcolm Baldrige Award criteria for Organizational Excellence. The judges for the award found that Tata Steel exhibited the following strengths:

- System based approaches in addressing many areas of the TBEM
- Demonstrable strength in processes addressing key customer and stakeholder needs
- Fact-based evaluation and improvement processes

Tata Steel also won the CII-EXIM Award for Business Excellence in November 2000. This award is based on the European Model for Business Excellence (EFQM). Tata Steel become the third company in India to win this award after Hewlett Packard India and Maruti Udyog Ltd., (the biggest car manufacturer in India) who have a Japanese collaboration with Suzuki Motors. In 2003 Tata Steel has won the TBEM sustainable award by getting 675 marks out of 1000 points based on Malcolm Baldrige criteria for Excellence assessed by experienced Baldrige Assessors along with the Tata Group Assessors. Despite difficult times in Steel industry worldwide as well as in India, Tata Steel has been always making net profit every year since its inception. World Steel Dynamics has identified 12 companies as World Class Steel Makers. Tata Steel of India has been rated on the top above Posco of South Korea, Nucor of USA and Nippon of Japan and other such companies.

#### **5. CONCLUSION**

By applying the Japanese Business Excellence Model, the Deming Prize as shown by two small auto component companies in India namely Sona Steering Limited and Sundaram Clayton which have won the Deming Prize in India have become globally competitive companies. It has been seen that by applying the principles of the American Model for Business Excellence and fine-tuning to the needs of an old and culturally strong Steel Company, Tata Steel, has inculcated the philosophy of Total Quality Management and Business Excellence as part of the company's Corporate Business Strategy. Any company can gain competitive advantage and move towards Business Excellence as described in this paper. Tata Steel, Sona Koyo Steerings Limited and Sundaram Clayton Limited in India have done this because of its foresight and the vision it had among the Top Management Leadership and support from all its employees in the company. These companies have as prepared themselves to compete and be successful in a competitive globalized world.



### Table 1. Key Customer for the Company

Maruti Udyog Ltd.	59.4% of sales
Mahindra & Mahindra Ltd.	20% of sales
Toyota	5.6% of sales
Hyundai	8.5% of sales
Tata Motors	5% of sales

### TQM Customer Centric -driven quality

TQM has a customer-first orientation. Customer satisfaction is the mantra and their satisfaction is taken as a measurement of success. The Company is sensitive to customer requirements and responds rapidly to them. In this context, **'being sensitive to customer requirements'** goes beyond defect and error reduction, and merely meeting specifications or reducing customer complaints.

To spread this message each individual department becomes one another's customer and their performance is measured through SLA as one's input being output to other.

#### Fast response

To achieve customer satisfaction, the company has to respond rapidly to customer needs. This implies short product and service introduction cycles. These can be achieved with customer-driven and process-oriented product development because the resulting simplicity and efficiency greatly reduce the time involved. The result is a dramatic improvement in the elapsed time from product concept to first shipment.

### 3 P's and TQM

#### 1. PROCESS

Continuous improvement of all operations and activities is core theme of TQM. Quality product is seen as the deliverables of customer satisfaction,

In order to enhance the product quality and customer satisfaction, TQM also recognizes that product quality is the result of process quality. As a result, there is a focus on continuous improvement of the company's processes which enhance process quality. Improvement cycles are encouraged for all the company's activities. In turn this will lead to an improvement in product quality, and to an increase in customer satisfaction.

#### Kill the diseases at its roots

Elimination of waste is a major component of the continuous improvement approach. There is also a strong emphasis on prevention rather than detection, and an emphasis on quality at the design stage. The customer-driven approach helps to prevent errors and achieve defect-free production. When problems do occur within the product development process, they are generally discovered and resolved before they can get to the next internal customer.

#### 2. PEOPLE

A successful TQM environment requires a committed and well-trained work force that participates fully in quality improvement activities. Such participation is reinforced by reward and recognition systems which emphasize the achievement of quality objectives. On-going education and training will be the prerequisites for enhancing quality. Employees are encouraged to take more responsibility, communicate more effectively, act creatively, and innovate. As people behave the way they are measured and remunerated, TQM links remuneration to customer satisfaction metrics. Employees have to be made to feel that they are responsible for customer satisfaction. They should feel they are important and recognized thus an integral aspect of the whole processes.

### 3. PRODUCT

Product development in a TQM environment is customer-driven and focused on quality. Teams are process-oriented, and interact with their internal customers to deliver the required results. Management's focus is on controlling the overall process, and rewarding teamwork. The product is the end result of a cumulative process implemented by the people.

#### **TQM leadership from top management**

TQM is a way of life for a company. The key point is that it has to be introduced and led by top management. Any initiative will not see its daylight in true spirit until and unless the tone is set at the top. Subordinates are often driven by superior's priority as they see their leaders are the communicators of corporate vision and mission. Until and unless leaders practice whatever they preach, their initiative will not percolate to the downstream.

#### **TQM & TBEM**

Nowadays 'Quality' and 'Business Excellence' are considered to be each side of one coin.

The quality movement in the Tata Group is known as the Tata Business Excellence Model (TBEM), which has been adapted from the renowned Malcolm Baldrige archetype and works under the aegis of Tata Quality Management Services (TQMS) to help different Tata companies achieve their business objectives through specific processes. These processes are driven by two factors: **business excellence and business ethics**. TBEM evolves around to achieve best practices through building robust processes.

#### **A Case Study – Improvement of Supply Chain Process & Involvement of People:**

Problem Description:

A Core Problem experienced by Tata Motors is that it is always operating in a time pressure situation to execute its plan into production. Our initial hypothesis is that simple process realignment (and not expensive software) that would be required to vastly improve Tata Motor's overall Supply Chain Management.

#### **2. Testing the Hypothesis:**

##### **Conducting a Supply Chain Evaluation:**

Conduct discussions with departmental managers including marketing, sales, production planning, purchasing, manufacturing, finance, and transport to develop an overall picture of the company's supply chain operations. These interviews will be followed by our preparing flow charts that enable us to track the flows and timing of materials and information from the moment orders were placed throughout the chain to the moment that customer deliveries will be made. All facets of the operation will be considered, including sales promotions, order booking, credit approval, sales forecasting, materials and ingredients purchasing, inventory management, order fulfillment, customer service, and final transportation to the customer.

##### **Develop a Task Force of involved employees:**

Appoint a dedicated manager to work with for this project and to bring together employees within the company having involvement in the various aspects of the supply chain management. This group of people will form a special Task Force, assigned with the responsibility of identifying ways to improve the flows of materials and information throughout the supply chain, including flows both to and from the company involving outside vendors. Weekly meetings to be held to address various issues and to find ways to resolve them to increase the inter-departmental synchronization of various supply chain management activities.

#### **3. Case Study Findings:**

Dealers are holding orders until the last minute before sending them to our RSO's in case there were any



changes to be made. This practice leaves very little time for our production team to make production adjustments to cover any possible inventory shortages.

Credit checks were frequently delaying the release of orders to the production-planning department. We found that the vast majority of orders were approved by credit, and that by informing the rest of the company that these orders were in "cue", preparations could be made to accommodate orders much faster once the accounting department released them.

The transportation department had been experiencing difficulty getting people to handle customer deliveries. We found that truckers were given less than 24 hours notice before orders were to be shipped, not allowing them enough time to position the necessary equipment at the customer's shipping location. The short lead time was mostly due to the fact that the transportation department was not informed of pending orders until the day before they were to be shipped.

#### **4. Case Study – Better Service & Cost Savings:**

By more effective communication with dealers/ vendors, we will be able to increase our production schedule by at least 1 month. In addition to this, we need to develop a reliable vendor base who can supply materials according to our Quality Standards and at the time we require. Unnecessary Inventory Holding (Both Finished Goods – Supply Float & Inspection Float and Raw Materials) is a redundant cost. Hence, if we can reschedule our production according to a fixed plan, we can reduce on Inventory Holding cost. At the same time, we can also ensure that product demand is met on time.

Also, instead of arranging for transportation of our vehicles once it is tested ok to RSO, we should get communication from end consumer that when they need our vehicle. Once we know that, we can back calculate and plan our production accordingly. The vehicle can be dispatched according to the desired dates and desired location as specified by the end consumer.

#### **Conclusion:**

These improvements are but a few examples of how our company can benefit from our **Supply Chain Management Consulting Services**. For example, we will also find that employee morale improves as a result of the increased levels of inter-department communication and cooperation. The company will perform well financially and competitively.

#### **1. Beginning the description, the agreement on leadership...**

Managers work on systems. Others work within systems. The step-by-step integration of the quality disciplines into the daily routine, into the core of the organization's soul is the management challenge. The integration is time consuming. A lifetime, maybe more, maybe forever. But, then, TQM is not a thing, not a place. It is a process, a journey, from where we are to excellence; a process of never ending improvement to a never attainable end:

There is no one road. The road to continuous improvement is unique for each reality. It is personal--personal for those on the journey, which is everyone in the organization, including managers. But for a manager it is more. It is tests of stamina, courage, and faith; it is challenges in style and skill. It demands adaptation. Continuous improvement, continuous change; not the same, not that far apart.

More than anything, TQM depends on people and people are not managed. They are led. Tom has described leadership. He will not find argument with me. However, all those who lead, are not managers. Leaders arise from any quarter. All those who have the title, the position, the responsibility, the boss's offspring in his or her bed, are not managers. Neither management nor leadership is bestowed by title, position, responsibility, or vows. The differences Tom describes are the differences between supervising and leading, between boss and leader. (And boss is bestowed.)

From anywhere, one can lead. One who takes the initiative, leads. One who demonstrates taking the initiative, more than leads. He or she develops leaders. Demonstrating commitment, the same. One who lives the belief, leads by example and empowers others to do the same via the very act of demonstration as well as via the transference of power. Empowered employees can establish

clear, attainable goals. Managers and employees, leaders all, can genuinely agree on those goals in theory and in practice because they are committed to improvement; improvement in their jobs, in the processes they touch, in the products they produce, and in themselves.

Deming, Juran, Glenn, teach us continuous improvement is slave to individuals and groups learning from error. Error is shown from comparisons: the actual versus the expected. Unbridled by fear, in concert with leaders, mistakes are teachers. Peer leaders and managers who lead; encourage, coach, and recognize--for the real victory in the process of continuous improvement is not the correction the error, but the learning from it.

## **2. Continuing the description; transition from leadership to management, systems...**

Along the road to perfection are obstacles and barriers.

Removal is essential. Who identifies them? Managers? Probably not--stinks of patronage. Leaders empower workers to identify the problems, but it is often left to managers and workers, working together, to remove barriers and obstacles. Leaders encourage the work, facilitate it, empower workers, and transfer ownership. Workers do the work, take ownership of the processes, and change the processes. But it is management that creates that system, that environment that allows, encourages, and, eventually, breeds this outstanding performance.

Awareness is people change, a job for leadership, and awareness is the result of systematic modification, a job for management. TQM requires individual awareness of the need to improve, awareness of the promise of the quality road, awareness of the philosophy of continuous improvement, and awareness of the tools and methods one employs in implementation. Leaders can bring people to the road; leaders can share their knowledge and experience for adaptation to the journey, but it is management that provides and ensures. Management ensures that workshops and conferences are there and accessible, that the TQM body of literature is enmeshed in the corporate psyche, that higher level management is attune to the changes, that there are mechanisms for horizon communication throughout the organization, that there are mechanisms that assure goals communicated downward are aligned with resources needs communicated upward, and that customers and suppliers are brought into the processes within the system.

Open, honest communication creates the environment in which TQM flourishes. The absence of open, honest communication assures a stunted growth, if not a demise for quality. Leaders know this. Leaders communicate openly and honestly. Leaders know they must spend a lot time listening, asking questions, and acting on answers. It is not simply that everyone knows what he or she needs to know. People are stilted in such an environment.

Continuous improvement is a "nonstarter" in an organization where everyone does not know everything. People need to know the vision, the organizational goals, the supervisor's objectives, the multiple agenda, and what is coming down the road. It is only in such an environment that people feel respected, trusted, and secure enough to offer the total, open, honest communication essential to TQM. It is in only in such an environment where suggestions for improvement can be relevant. Only systematic change and managerial commitment can create the mechanisms that can assure that clear lines of communication are open throughout the organization and that they are open and functioning vertically as well as horizontally.

## **3. Continuing the description; management as umbrella, constancy of purpose...**

Up to now, a manager has been working on the processes of the organization. The system components he or she has been manipulating, have been those components that directly impact the processes. Since the processes are the business of the organization, success or failure was fully dependent on involving everyone in the organization. The need to involve everyone in the continuous improvement effort never ends. But if it is only strength of character that drives quality, the "leader" has become the indispensable man. [Tom Peters, "Liberation Management," discusses the problems of the indispensable man in some detail and provides specific examples how one can cure such behavior.] It is the



responsibility of management to provide the environment, the system that allows (indeed facilitates and encourages) outstanding performance; that ensures the organization adopts the philosophy. While everyone is important and ought to be made to feel that way, no one should be allowed to become indispensable. It is the antithesis of team.

Management must create constancy of purpose. There must be common direction for all the organizational components, and all the organizations components must contribute to attainment of the organization's objectives. This requires first an organizational mission. While the statement may be a product of the organization, it is management that will launch it, that must see the need for it.

The improvement of processes is not a long term vision—although, granted, it is a long term commitment. The long term vision is not the mission either. It is a statement of where TQM, the road of continuous improvement, is to take the organization. Again, a product of the entire organization, maybe; but it is management driven and management's responsibility to ensure its creation and dissemination throughout the organization. It is a management duty to provide the boundaries—mission and vision.

These managerial activities, mission statement, vision statement, serve as the foundation for strategic planning—a managerial responsibility. Strategic planning should generate long term goals and specific, short term objectives for the improvement process. It is the duty of management to ensure that all the goals are meaningful.

Management responsibility to the system continues with the deployment of policy throughout the organization. Again I will say this, but for the last time. The work of creating these things is not done in a back room. Teams, with representation from throughout the organization, to do the work and to make the recommendations, is the preferred mechanism. But the exercises one undertakes to create or to modify systems are the essence of management. (It takes leadership to get it done.)

Continuing with deployment.... [For those who would like to see this discussed in more detail, you might try Juran's book, "Planning for Quality." He takes the reader step by step from identify the customer to deployment with considerable detail. (And he writes clear, readable text.)] Deployment is multiple processes. It is the process by which organizational goals become detailed, specific objectives with resource requirements and commitments. It is also a process by which management can assure that its goals and the goals of the components are in alignment with one another, with the mission, and with the vision.

This (deployment) is a particularly dangerous exercise for management. Its responsibility is to ensure the exercise does not trip over into the old numeric game. Goals deployed must be faithful to the spirit of TQM. They have to be goals for improvement not for achieving a result. If slippage occurs, the result may be an improved system, but it is just as likely to be a bastardization of the system such that progress in one area is at the expense of another (often not identifiable at once; often producing a net loss) or, in true Deming misery, the figures are distorted. Management has to guard that the assessment of performance stays focused on how well people are improving the processes, not on how close to the numeric goal people have come.

Self evaluation and self correction can easily become self promotion; competition, not cooperation if the management is unskilled or uninformed.

#### **4. Continuing the description; focusing on the customer and using teams...**

The focus of quality must be the customer. Linking organizational purpose to customer satisfaction is much more than an exercise in leadership. Just identifying customers requires an alien mind set. Anyone can see that those outside the organization are customers. It is much more difficult to bring to the organization the realization that everyone in the organization affected by the processes in which one is involved, is a customer. Note the word employed here is, "realization," not "recognition" or some other wimpy commitment. Realization denotes one is committed to learning the needs of his or her coworkers and satisfying them with the same zeal and with the same success one satisfies a stranger.

Satisfying customers continues with—after identification, which is itself a management chore—

understanding customers; understanding their needs, their expectation, and their requirements. This often means understanding the customer better than the customer understands his or herself and understanding him or her implicitly. It means establishing meaningful dialogue, listening, involving the customer in the organization's planning and in the organization's deciding.

Teams are the engine that propels continuous improvement, and successfully functioning teams are the vehicles that include everyone in the improvement effort. I would not argue that leadership is often the difference between a successfully functioning team and something less. However, the little computer that keeps it together, that gets all the cylinders firing cooperatively, is management. Teams do not spontaneously birth. Without constancy of purpose, teams develop conflicting and counterproductive goals. The work of teams in TQM is managed participation, and it is essential that teams develop goals and pursue improvements that reinforce one another as well as contribute to the vision and to the mission.

Cross-functional teams are not natural. It takes a Dr. Frankenstein (a manager) to bring individuals from several functional components together, to provide the system that facilitates peer collaboration. [I have to concede, separating the mix of management responsibility and leadership skill that raise the behavior of individuals on cross-functional teams above parochialism and evolve a "team think" concentration on common processes is extremely delicate surgery indeed.] Teams not devoted to improvement also have a place, and management has to know when an emerging problem demands immediate attention. Short term, problem solving teams have been a mainstay in the managerial toolbox for generations, and they have place in TQM.

Managerial responsibility is to foster the system that eventually includes everyone on an improvement team. Management must also ensure that process improvement teams are linked vertically and horizontally. Vertically: lower-level teams function consistently within the expectations of higher levels and the organization as a whole proceeds logically.

Horizontally: cross-functional groups address common problems and the lessons learned in one area are applied in another with duplicative effort.

### **5. Continuing the description; common subject, different perspective on education and training...**

Earlier I spoke of education and training as a mix of leadership and management; how a leader can teach and the responsibilities of management to insure that educational resources (workshops, conferences) are there. But the greater managerial responsibility is the creation of a system that ensures adequate time as well as sufficient availability of the more traditional training resources.

Management must, in the final analysis, decide if the organization will develop organizational-specific training approaches or use (or adapt) exiting resources and materials. It is management that is responsible for the personal and professional development of its people. It has to first recognize that training in the TQM environment is continuous and management has to arrange for continuous training. The training has to be consistent, a managerial responsibility. There must be a common level of understanding about TQM principles, techniques, tools, and skills throughout the organization. Managers and supervisors have to be trained; management must ensure it happens.

Managers must create the time for improvement. Time has to be provided not just for the effort, but for the training (OJT and in the classroom). Time must be provided for team meetings. Time must also be provided for the independent activities associated with TQM; such as, data collection and analysis.

Managers must organize it all to support continuous improvement. The organizational structure that mirrors the improvement effort, facilitates the effort.

### **6. Continuing the description; bringing it all home, making Total Quality Management (not Total Quality Leadership) the over arching philosophy...**

If continuous improvement becomes one with the organization it will survive and the organization will thrive. It (continuous improvement) must become the routine, the normal approach; it must become



the system. The organization must expect improvement; not simply that the leader (or leaders) expects improvement, but that everyone in the organization, peers, subordinates, and superiors expects improvement, and everyone outside the organization, customers and suppliers (see part seven) expects improvement. These are not expectations born of criticism and punishment, but expectations born of a systematic unwillingness to accept less.

The re-characterization of problems to opportunities requires an organization poised to milk “problems” for the potential for improvement inherent in their existence. It requires not just acknowledgement of their existence, but an active, systematic effort to ferret them out as well as a rewards system for those who surface them [still a subject for future debate]. Depending upon the maturity of TQM in the organization, there will be policies and routines out of alignment with the philosophy of TQM that must be systematically eliminated, and, as TQM matures, new TQM-contradictory policies and routines will be introduced. They too must be identified and eliminated, or brought into alignment.

It is a basic tenet of TQM that fear has to be driven from the work place and out of the organization. We need only look to the reinventing government movement to see that failed management does not drive out fear, it embeds it: the shoot the managers credo, penalizing problem finders by requiring finders without ownership to solve the problems they illuminate, and the disregard for survival--the first and most basic need--with the threats of job loss and the message, “go away.” The inevitable results of this managerial myopia create environments and systems that leadership cannot set right. Resolution requires a systematic realignment of the vision itself, of the vision with the goals, and of the strategic and implementation plans with the vision and the goals. Given the body of literature available, it is mind boggling that the body politic has come to believe that TQM can be implemented by fiat, without evolution, and without hard, dedicated work.

The rewards and recognition systems have to be aligned with the TQM philosophy. [I will not address this here with the intention of debating the role of these systems in TQM at some future date.] “Leading Teams” by (I think it was) Zenger et. al. and “The Customer Comes Second” by Rothenblath contain some interesting discussions of the subject.] [Apologies is I’ve spelled the names of these authors incorrectly. I’m writing in a place where I don’t have access to my personal library.]

The move to stop reliance on mass inspections--another basic tenet--has to come from management. When working people are producing products that are accepted or rejected on the basis of inspection, the incentive and the result is to produce products “good enough” to pass inspection--hardly an acceptable definition of quality by any standard.

Lastly, making quality part and parcel to the organization also requires management take a fresh look at the way it justifies cost. Juran tells us [“Designing for Quality”] that the only valid comparisons are total cost to total cost. [E.g., a hammer with a five dollar price tag that last three months “costs” an organization an amount many fold more than does a as hammer with a thirty or fifty dollar price tag that lasts a lifetime.]

## **7. Expanding to suppliers...**

The emphasis on customers is so pervasive in the conception of TQM, the necessity to bring suppliers into the picture can be overlooked. That oversight, particularly in cases of competition, can differentiate the winners from the losers. The Juran Trilogy, supplier, processor, customer, is everywhere all the time; every process and each of us is a supplier, a processor, and a customer. We may look at this at its most basic level: a person (supplier) gives something to another, who does something to it (processor), and gives it to another who needs it (customer). And we may look at this at its most macro level and its essence is unchanged: Japan (supplier) provides steel to Canada (processor) which make a automobile sold in the U.S. (customer). No matter what magnification our perception, inclusion of the supplier requires multiple processes (a system) and a commitment, which, in the case of an organization, is a management undertaking.

Bringing the supplier into the system is much more than inviting her representative to attend meetings. We might begin with the purchasing process; eliminate redundancy, unnecessary processes, and



procedures not worth the effort. With a mature TQM in place, management could forget a host of safeguards in favor of trust and forget a litany of specifications to which lowest price competitors bid and in which they invest heavily to undercut.

One reason management must be committed is the time it takes for TQM to mature in an organization; years. Getting all one's ducks in order within the organization and with the external customers before bringing suppliers into the system just delays maturity and leaves a gap for competing, better managed TQM organizations, to fill. Suppliers should be involved early and pervasively. Each benefits from the lessons the other learns. It is in the organization's best interest to help suppliers improve--after all, what better insurance of quality supplies? by conducting supplier work shops, permitting suppliers into organizational training, implementing personnel exchange programs, and (and it is a BIG AND) making the intra organizational data available to them--this is pure Juran; pure management.

When the teams begin to form, the organization who's management engages suppliers in mutual problem solving, mutual improvement exercises, is the organization with the edge and the organization with the more mature system. Organizational management should reward improving suppliers. Longer term contracts, additional contracts, better profit margins, reduced oversight are examples of managerial reward. But probably the best reward for suppliers and organization alike is reduction in the number of suppliers. Deming ["Out of the Crisis"] is quite clear in his guidance on this: we invest time and resources and create for ourselves the opportunity for closer, long term alliance with fewer suppliers. Win, win. [Deming: "The New Realities"] The TQM process allows us to quite clearly identify the best suppliers; the ones with whom we want to establish an extended relationship. They are the ones who focus on team work, who have the total commitment and (conceding a point) leadership from top management, who have a vision of continuous improvement, and whose emphasis on improvement is data driven.

### **A Case Study: Alignment of IT Objectives with Business Objectives.**

One of the major challenges faced by us in inducting a TQM culture is to develop a sustainable alignment with the user culture and requirement of TQM. In the following case study, we would analyse a problem faced and discuss the possible alternatives.

TQM program has three main components -- Just in Time (JIT), Total Quality Control (TQC) and Total Employee Involvement (TEI). The relationship between the three legs of TQM is as following:

- (i) JIT exposes the cause of problems;
- (ii) TQC helps provide a solution to problems.
- (iii) TEI involves the employees in the process of change since they do all improvements.

This study is evolves around a situation where the effort is to align the IT with the business process and focuses on the TEI aspect.

Every organisation, before inducting a study of process harmonisation, would have processes that were determined either by individuals in charge of the process or is a part of the organisation culture. Whatever the origin, such practices has deep rooted acceptance in the organisation and it is a difficult task to even to advocate a change. Once the users are required to relearn a process – a certain amount of insecurity comes in as they are not sure whether they can reach their achieved level of efficiency under the new system. Whenever the users have found that the changed system will improve their demonstrated efficiency level, there always is a ready acceptance for the same.

To be fair to the internal users, it must also be pointed out that the external vendors try to reengineer the process to suit their standard solution – thus saving effort and possible chances of compromise of the level of efficiency associated with customisation. Since in majority of the cases the vendors deal is a technology which has proved benefits and internal users are not in a position to influence the solution specification, most organisations agree to re-engineer their process rather than opting for costly customisation. Financially this also looks a better alternative since the total cost of ownership rarely takes into account the user discontent and lower productivity during initial days.

In the instant case, the users were uninitiated about the requirement of IT discipline and formalities which are envisaged by relevant quality control standards and practices viz. ISO27001 or the regulatory requirement like SOX implementation where our IT vendor IBM has to do according to requirements of IT General Control under SOX.

The users are well trained and extremely competent on their functional interface with the system. Recently they have gone through an exercise of user management and change management. This exercise was done internally and informal channels of communication were used to sensitise the employees. In addition, the entire affected system was managed internally. Consequently peer group pressure could be used to obtain the buy in of the internal users.

Having been through such an exercise, the users were cold to the process of implementing best practices in the area of discipline and formalities. In addition this exercise was being conducted by an external vendor whose understanding of the internal dynamics of the organisation was limited. The vendor (IBM) was also under pressure from the Top Management as well as the External auditors to implement the changes at the earliest. This made providing time for internal negotiation to promote the idea of the proposed change almost impossible. The situation was highlighted by a group of agitated user and impatient vendor.

An analysis of the situation brings forth the fact that the users were not involved in the decision making process and hence were ignorant about the benefits that would arise with the changed system. It must be noted, that in the process of maximising benefit of the organisation, unless the employees feel that their individual benefits are also being addressed to, it is always difficult to get the spontaneous support from them.

A study of the reason behind the lack of user acceptance brought forward a singular reason – users were not convinced of the benefit. This clearly points out to complete failure of selling the concept to the internal customers – which leads to a stark reality – the implementation did not recognise the role of the human asset in the entire system. In the milieu of system, hardware, software, and process – an important cog in the wheel went unnoticed. In an individual interaction, whenever the discontented employees were explained the rationale behind the project and how they benefit from the same – the reaction was always positive and for the project. All that was required to be done is to formalise the function of information dissemination and doubt clarification.

**Lessons learnt in this exercise include the following:**

- (i) We often consider an IT driven system as the complete solution not recognising the critical role the users play in the process
- (ii) Users must be consulted in any decision involving re-engineering of the process
- (iii) Users must be trained, not only in the operation of the solution, but also to recognise the benefits arising to them
- (iv) Users must be convinced that re-engineered process does not involve additional work – but essentially involves realignment of the work. If such a conviction cannot be logically achieved, the organisation must revisit the expected benefits from the project. If re-engineering cannot improve the efficiency expressed as input output ratio – there may not be any merit in going for the same.
- (v) The organisation must consider the discontent among the employees including the impact on productivity while computing the total cost of ownership.
- (vi) The solution provider must recognise and respect the domain expertise of the users and not push them into buying their suggested process of work.
- (vii) In any process improvement decision, a comprehensive view of the organisation must be taken in line with ISO20000. A departmental view will only shift from the problem from one department to another.

Organisations will need to improve their processes and will have to face some amount of discontent from the users. In addition to adopting a strategy to minimise such dissidence, the organisation will also need to evaluate whether discontented employees are an acceptable result of a process improvement activity.

Process cannot be without the involvement of people but organisation must sell the idea of any change management to get full support from them and people also should understand that without being ready to adapt the changes, organisation will not survive thus in turn they will also not survive.



---

# **Section C**

## **Enterprise Risk Management**

---





# Study Note - 8

## ENTERPRISE RISK MANAGEMENT



This Study Note includes

8.1 Risk Management

8.2 Corporate Risk Management

### 8.1 RISK MANAGEMENT

Risk management has become the most important topic for banks in the recent years. Addressing risk management in the context of current challenges is a complex matter and a function of appropriate policies, procedures and culture. Risk management will be successful if the word risk is understood well and clearly.

#### Risk

According to Dowd (2005), Risk refers to the chance of financial losses due to random changes in underlying risk factors.

A risk is a random event that may possibly occur and, if it did occur, would have a negative impact on the goals of the organization. It is the probability of incurring loss due to unexpected and unfavorable movement of certain parameters.

Risk is composed of three elements — the scenario, its probability of occurrence, and the size of its impact if it did occur (either a fixed value or a distribution). Risk is thus measured by volatility.

An opportunity is also a random variable which is the other side of the coin! But it has a positive impact on the goals of the organization.

In the corporate world, accepting risks is necessary to obtain a competitive advantage and generate profit. Introducing new product or expanding production facilities involves both return and risk. When a company is exposed to an event that can cause a shortfall in a targeted financial measure or value, this is financial risk.

#### Types of RISK

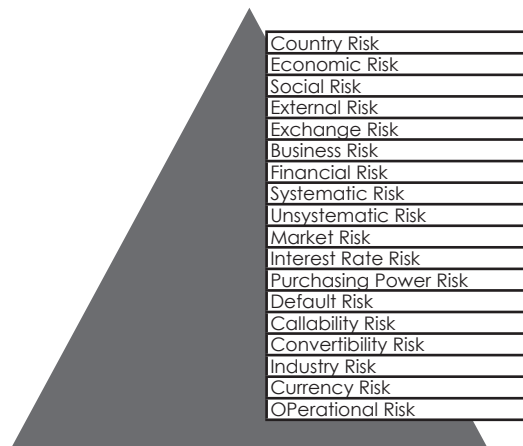

**Risk can be of the following types:**

**Political Risk:** Political risk is defined as “the possibility of a multinational company being significantly affected by political events in a host country or a change in the political relationships between a host country and one or more other countries”. Political risk is the unwanted consequences of political activities that will have effect on the value of the firm. The multinational companies which are making foreign direct investment must assess the political risk, before any such investments are made. The political component in country risk can be subdivided into two categories, internal political risk and external political risk. Internal political risk arises due to internal conflicts such as racial/religious riots, rebellions, rural/separatist insurgency or political turmoil. Such activities tend to destabilize the state, which will in turn result in delays or defaults in the repayment of loans. External political risk is exposure to loss as a result of acts such as war or occupation by foreign powers, while a war may cause a delay in the repayment of debts. Occupation of foreign power may result in default, as the new power may not reorganize the debt obligations of the former Government. The possibility of such political upheaval needs to be carefully evaluated by the lender before releasing funds to a foreign state.

**Country Risk:** The country risk is defined as exposure to a loss in offshore lending, caused by events in a particular country, events which are, at least to some extent, under control of the Government but definitely not under the control of a private enterprise or individual. Country risk is a broad concept encompassing sovereign, political as well as other forms of risks like economic, social and external risks. Since country risk is the sum total of a number of different types of risk, assessing country risk would mean the evaluation of each of these risks that contribute towards it. The country risk is an all embracing term incorporating all types of risks a lender encounters in offshore lending. Country risk means with reference foreign funding the possibility that a borrower will be unwilling or unable to service its debt in a timely fashion - the risk from cross-border lending that arises from events to some degree under the control of the Government of the borrowing country. Country risk is inherent with dealing of state (sovereign risk) or any overseas business. The assessment of country risk, involves both qualitative and quantitative analysis of political, social, economic and natural conditions in the country in which the borrower operates.

**Economic Risk:** Economic risk is concerned with the general economic climate within the country. Some of the factors which reflect the economic climate of a country are:

- (a) level of affluence enjoyed by the country.
- (b) the growth rate of income.
- (c) the nation's propensity to save/invest.
- (d) the stability of prices (inflation).
- (e) characteristics of the labour force.
- (f) level of sophistication of the financial system.
- (g) level of foreign debt outstanding.
- (h) major income earners (exports) and their sensitivity to overall global economic changes.
- (i) extent of dependence on major export items.
- (j) trends in balance of payments.
- (k) level of imports
- (l) level of reserve and credit standing, and
- (m) fluctuations of exchange rate and controls on foreign exchange.

**Social Risk:** Social risk refers to the possibilities of loss due to factors such as religious fanaticism, ethnic polarization, dissatisfaction among the people as a result of wide disparity in income distribution, or



regionalism. These sociological problems eventually lead to riot and revolutions resulting in loss of lives and property. An economy plagued by riots and revolutions will undoubtedly face problems in repaying its debts.

**External Risk:** The external risk component of country risk arises due to situations outside the country. For instance, if the borrower nation is situated beside a country which is at war, the country risk ratios of the prospective borrower will be higher than what will be the case if its neighbour is at peace. This difference in the risk rating is attributable to external risk. Although the borrower nation may not be directly involved in the conflict, the chance of spillover may exist. Additionally, the borrower of refugees fleeing the war may upset the economic conditions in the borrower nation. Hence, the lender has also to consider the external environment of the prospective borrower before sanctioning the loan.

**Exchange Risk:** Since the liability of the borrower of the foreign currency financing remains in the currency in which the borrower obtains loan, so at the time of repayment the rupee liability is determined on the basis of the exchange rate prevailing on the date of repayment. The exchange rate fluctuates widely with the passage of time, so the borrower is subject to exposure to exchange rate fluctuations on the outstanding principal of the foreign currency financing. Further if the borrowing is made at a floating rate of interest, there can be substantial variations in the rate of interest with the passage of time, depends on the variations in the LIBOR.

**Business Risk:** A company's business risk is determined by how it invest its funds i.e., the type of projects which it undertakes, while financial risk is determined by how it finances these investments. A company's competitive position, the industries in which it operates, the company's market share, the rate of growth of the market and the stage of maturity all influence business risk. Business risk relates to volatility of revenues and profits of a particular company due to its market conditions, product mix, input availability, competitive market condition, labour supply etc. The business risk may be due to external factors or internal conditions of a particular business firm. External business risk arises due to change in operating conditions caused by conditions thrust upon the firm which are beyond its control - such as business cycles, Governmental controls etc. Internal business risk is associated with the efficiency with which a firm conducts its operations within the broader environment imposed upon it.

**Financial Risk:** Financial risk is primarily influenced by the level of financial gearing, interest cover, operating leverage, and cash flow adequacy. The financial risk depends on the method of financing adopted by the company. Financial risk is associated with the capital structure of a firm. A firm with no debt financing has no financial risk. The extent of financial risk depends on the leverage of the firm's capital structure. A highly geared firm may face the problems like high cost of equity and debt funds, cash flow problems in servicing off debt obligations, constraints on management control, fall in profits available to equity holders etc. The financial risk will also arise due to short-term liquidity problems, shortage of working capital, inefficiency in collection of receivables, bad debts, funds tied in excess inventories, long operating cycle etc.

**Systematic Risk:** Systematic risk refers to that part of total risk which causes the movement in individual stock price due to changes in general stock market index. Systematic risk arises out of external and uncontrollable factors. The price of individual security reflects the fluctuations and changes of general market. Systematic risk refers to that portion of variation in return caused by factors that affect the price of all securities. The effect in systematic risk causes the prices of all individual shares/bonds to move in the same direction. This movement is generally due to the response to economic, social and political changes. The systematic risk cannot be avoided. It relates to economic trends which affect the whole market. When the stock market is bullish, prices of all stocks indicate rising trend and in the bearish market, the prices of all stocks will be falling. The systematic risk cannot be eliminated by diversification of portfolio, because every share is influenced by the general market trend.

**Unsystematic Risk:** Unsystematic risk is that portion of total risk which results from known and controllable factors. Unsystematic risk refers to that portion of the risk which is caused due to factors unique or related to a firm or industry. The unsystematic risk is the change in the price of stocks due to the factors which are particular to the stock. For example, if excise duty or customs duty on viscose fibre increases, the



price of stocks of synthetic yarn industry declines. The unsystematic risk can be eliminated or reduced by diversification of portfolio. Unsystematic risks are those that are unique to a particular company or a particular investment, resulting downward movement in the performance of one company can be offset by an uptrend movement in another and so much of this unsystematic risk can be eliminated through diversification on the part of the shareholders when they hold a portfolio of shares. The systematic risk attached to each of the security is same irrespective of any number of securities in the portfolio. The total risk of portfolio is reduced, with increase in number of stocks, as a result of decrease in the unsystematic risk distributed over number of stocks in the portfolio.

**Market Risk:** The market risk arises due to changes in demand and supply, expectations of the investors, information flow, investor's risk perception etc. Variations in price sparked off due to real social, political and economic events are referred to as market risk.

**Interest Rate Risk:** The return on investment depends on the market rate of interest, which changes from time to time. The cost of corporate debt depends on the interest rates prevailing, maturity periods, creditworthiness of the borrowers, monetary and credit policy of the central bank, riskiness of the investments, expectations of the investors etc. The uncertainty of future market values and the size of future incomes, caused by fluctuations in the general level of interest are known as 'interest rate risk'. Generally, price of securities tend to move inversely with changes in the rate of interest.

**Purchasing Power Risk:** Uncertainties of purchasing power is referred to as risk due to inflation. If investment is considered as consumption sacrificed, then a person, purchasing securities, foregoes the opportunity to buy some goods or services for so long as he continues to hold the securities. In case, the prices of goods and services, increases during this period, the investor actually loses purchasing power. The investors expected return will change due to change in real value of returns. The risk in prices due to inflation will cause to rise in cost of production and reduction in profit due to lower margins. The supply of money, monetary and fiscal policy of the Government will cause the changes in inflation. The investors' expectations will also change with the changes in levels of purchasing power. The purchasing power risk is inherent in all securities, which is uncontrollable by the individual investors.

**Default Risk:** The default risk arises due to the default in meeting the financial obligations as and when due for payment. The non-payment of interest and principal amounts in time will increase the risk of insolvency and bankruptcy costs. The default risk or insolvency risk will cause a sudden dip in company's stock prices.

**Liquidity Risk:** It is that portion of an asset's total variability of return which results from price discounts given or sales commissions paid in order to sell the asset without delay. It is a situation wherein it may not be possible to sell the asset. Assets are disposed off at great inconvenience and cost in terms of money and time. Any asset that can be bought or sold quickly is said to be liquid. Failure to realize with minimum discount to its value of an asset is called liquidity risk.

**Callability Risk:** It is that portion of security's total variability of returns that derives from the possibility that the issue may be called or redeemed before maturity. Callability risk commands a risk premium that comes in the form of a slightly higher average rate of return. This additional return should increase as the risk increases.

**Convertibility Risk:** It is that portion of the total variability of return from a convertible bond or a convertible preferred stock that reflects the possibility that the investment may be converted into the issuer's common stock at a time or under terms harmful to the investor's best interests.

**Industry Risk:** It is that portion of an investment's total variability of return caused by events that affect the products and firms that make upon industry, the stage of the industry's life cycle, international tariffs and/or quotas on the product produced by an industry.

**Currency Risk:** These are associated with international investments not denominated in the home currency of the portfolio manager's beneficiaries. These risks involve the international payment of cash.

Currency risks on a global basis may be close to unsystematic, meaning that they are uncorrelated across economies and are not priced.

**Operational Risk:** Operational risk arises primarily due to deviation from planned normal functioning of system, procedures, technology, human failure, omission or commission of errors. It also arises due to inherent fault in the systems, procedures and technologies that affect the revenue of the organization adversely. As the activities of the organization change due to globalization and integration, new factors are continuously influencing and increasing the operational risk.

### 8.1.1 Definition of Risk Management

Risk management is the process of measuring or assessing risk and developing strategies to manage it. Risk management is a systematic approach in identifying, analyzing and controlling areas or events with a potential for causing unwanted change. It is through risk management that risks to any specific program are assessed and systematically managed to reduce risk to an acceptable level. Risk management is the act or practice of controlling risk. It includes risk planning, assessing risk areas, developing risk handling options, monitoring risks to determine how risks have changed and documenting overall risk management program.

According to Deventer, Imai & Mesler (2005), it is the discipline which makes us appreciate the risks and returns from various portfolio and transaction-level strategies. At portfolio level, CEO, Chief Risk Officer (CRO), RMD, ALCO manages the risks in a Banking Institution. At transaction level, Trader, Swap dealer, loan officers manages the risk. The risks from individual transactions might be diversified away at the portfolio or institution level.

Risk management is a systematic approach to setting the best course of action under uncertainty by identifying, assessing, understanding, acting on and communicating risk issues. A Key ingredient of the risk measurement process is the accuracy and quality of master data that goes into the computation of different aspects of risk. It is no surprise therefore that Master Data Management is a key area. Risk management is first and foremost a 'science' and then an 'art'. Given the appetite for risk, if one uses accurate and relevant data, reliable financial models and best analytical tools, one can minimize risk and make the odds work in one's favour.

Risk Management process needs to identify measure and manage various risks so that comparison of risks and returns is possible to set corporate strategies. Risk Management is the identification and evaluation of risks to an organization including risks to its existence, profits and reputation (solvency) and the acceptance, elimination, controlling or mitigation of the risks and the effects of the risks.

Risk Management framework need a common metric to rank return and potential losses from different portfolios and risk categories.

Integrated risk management is a continuous, proactive and systematic process to understand, manage and communicate risk from an organization-wide perspective. It is about making strategic decisions that contribute to the achievement of an organization's overall corporate objectives.

### 8.1.2 Objectives of Risk Management

Risk management basically has the following objectives:

- (a) Anticipating the uncertainty and the degree of uncertainty of the events not happening the way they are planned.
- (b) Channelizing events to happen the way they are planned.
- (c) Setting right, at the earliest opportunity, deviations from plans, whenever they occur.
- (d) Ensuring that the objective of the planned event is achieved by alternative means, when the means chosen proves wrong, and
- (e) In case the expected event is frustrated, making the damage minimal.

### 8.1.3 Risk Management Process

Risk management process refers to the process of measuring or assessing risk and then developing strategies to manage risk. In the risk management, the following steps are taken up to minimize the risk:

**Step 1: Risk Identification and Assessment**

This step involves event identification and data collection process. The institution has to put in place a system of capturing information either through key risk drivers (KRIs) or through a rating system. Once risks are identified, combine like risks according to the following key areas impacted by the risks — people, mission, physical assets, financial assets, and customer/stakeholder trust.

**Step 2: Risk Quantification and Measurement**

The next step is to Quantify and Measure risks-this means Rate risks according to probability and impact. Various standard tools are used by financial institutions to measure risk and understand their impact in terms of capital or its importance to the organization through a scoring technique.

**Step 3: Risk Analysis, Monitor and Reporting**

The next step is risk analysis, monitoring and reporting. This will help one to get the big picture and decided on the approach to risk management.

**Step 4: Capital Allocation**

Risk Analysis, Monitoring & Reporting sends information to the top management of the organization to take strategic decisions. Capital allocation plays key role in management decision making.

**Step 5: Risk Management and Mitigation**

After the above step, the last step is to make strategic decisions to manage the risk in order to mitigate the risk.

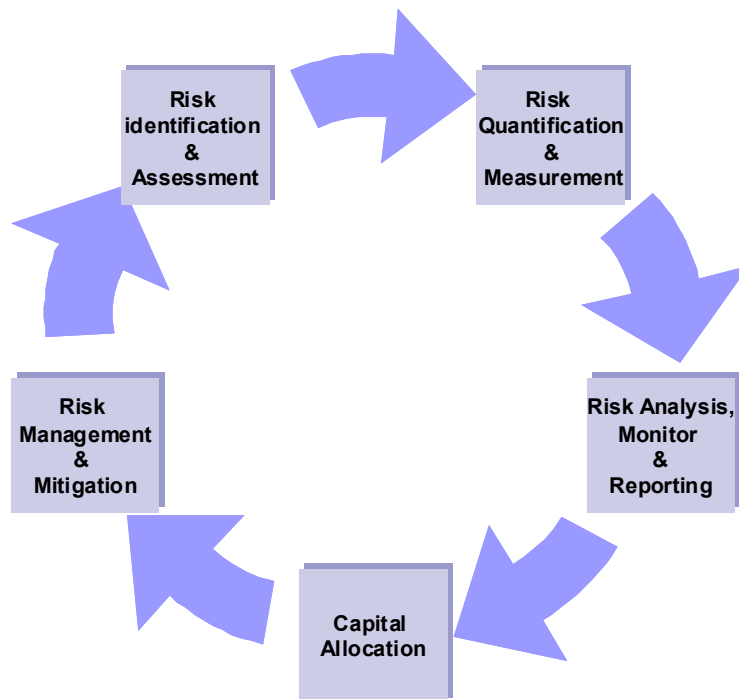



## Strategic Decision for Risk Management

**Risk Handling:** In ideal risk management, a prioritization process is followed whereby risks with the greatest loss and the greatest probability of occurring are handled first, and risks with lower probability loss are handled later.

**Risk Reduction:** This strategy is attempted to decrease the quantum of losses arising out of a risky happening e.g. earthquake, storm, flood etc. It involves methods that reduce severity of the loss arising from risk consequences. Risk reduction can be achieved through (a) loss prevention, and (b) loss control.

**Risk Avoidance:** This is prevention and a proven strategy. This strategy results in complete elimination of exposure to loss due to a specific risk. It may involve avoidance of an activity, which is risky. It includes deliberate attempt on part of the person taking risk decision not to perform an activity or not to accept a proposal, which is risk prone. This strategy can be approached in two ways: (a) Don't assume risk, and (b) Discontinue of an activity to avoid risk.

**Risk Retention:** This strategy is adopted when risk cannot be avoided, reduced or transferred. It involves accepting the loss when it occurs by taking risky proposal or risky assignment where there are no other alternatives to avoid risk. It can be a voluntary or involuntary action. When it is voluntary, it is retained through implied agreements. Involuntary retention occurs when the organization is unaware of the risk and faces it when it comes up.

**Risk Transfer:** It means causing another party to accept the risk, typically by contract. It involves a process of shifting risk responsibility on others. Insurance is one type of risk transfer, which is widely used in common parlance.

**Risk Hedging:** It is a systematic process of reducing risk associated with an investment proposal or in some other assignments where risk is inevitable i.e. the risk is of such nature that it cannot be avoided altogether.

**Risk Diversification:** It involves identifying both systematic and unsystematic risks. Systematic risk is inherent and is peculiar to the type of business/firm and can be reduced or diversified through functional level strategy. The unsystematic risk is external to the organization and is termed as 'market risk'. The identification of characteristics of market risk through statistical correlation 'beta, which is a measure of market risk, lends itself for manipulation through portfolio management. This strategy is followed in reduction of risk of single portfolio by investing in shares, debentures, bonds, treasury bills etc. to reduce overall risk of the portfolio.

**Risk Sharing:** Taking an insurance coverage for the exposure is the common method of sharing risk. By paying insurance premium, the company shares the risk with an insurance company. The insurance company can also share its risk with other insurance companies by doing reinsurance.

**Risk Pooling:** It is the process of identification of separate risks and put them all together in a single blanket, so that the monitoring, integrating or diversifying risk can be implemented.

### 8.1.4 Risk Measurement

Evaluation of the likelihood and extent or magnitude of a risk is known as Risk Measurement. In other words, it can be defined as a real valued function numerically representing an individual decision maker's risk ordering on a given set of alternatives. It quantified the amount of perceived risk. It provides fundamental support to decision making within the insurance industry.

#### 8.1.4.1 Risk Pooling

One of the forms of risk management mostly practiced by insurance companies is Risk Pool. Under this system, insurance companies come together to form a pool, which can provide protection to

insurance companies against catastrophic risks such as floods, earthquakes etc. The term is also used to describe the pooling of similar risks that underlies the concept of insurance. While risk pooling is necessary for insurance to work, not all risks can be effectively pooled. In particular, it is difficult to pool dissimilar risks in a voluntary insurance market, unless there is a subsidy available to encourage participation.

Risk pooling is an important concept in supply chain management. Risk pooling suggests that demand variability is reduced if one aggregates demand across locations because as demand is aggregated across different locations, it becomes more likely that high demand from one customer will be offset by low demand from another. This reduction in variability allows a decrease in safety stock and therefore reduces average inventory.

The three critical points to risk pooling are:

- (1) Centralized inventory saves safety stock and average inventory in the system.
- (2) When demands from markets are negatively correlated, the higher the coefficient of variation, the greater the benefit obtained from centralized systems i.e., the greater the benefit from risk pooling.
- (3) The benefits from risk pooling depend directly on the relative market behaviour. If we compare two markets and when demand from both markets is more or less than the average demand, we say that the demands from the market are positively correlated. Thus the benefits derived from risk pooling decreases as the correlation between demands from the two markets becomes more positive.

The basis for the concept of risk pooling is to share or reduce risks that no single member could absorb on their own. Hence, risk pooling reduces a person or firm's exposure to financial loss by spreading the risk among many members or companies. Actuarial concepts used in risk pooling include:

- (A) Statistical variation.
- (B) The law of averages.
- (C) The law of large numbers.
- (D) The laws of probability.

#### **8.1.4.2 Risk Reduction through Diversification**

The important principle to consider that in an efficient capital market, investors should not hold all their eggs in one basket; they should hold a well-diversified portfolio. In order to diversify risk for the creation of an efficient portfolio (one that allows the firm to achieve the maximum return for a given level of risk or to minimize risk for a given level of return), the concept of correlation must be understood. Correlation is a statistical measure that indicates the relationship, if any, between series of numbers representing anything from cash flows to test data. If the two-series move together, they are positively correlated; if the series move in opposite directions, they are negatively correlated. The existence of perfectly correlated (especially negatively correlated) projects is quite rare. In order to diversify project risk and thereby reduce the firm's overall risk, the projects that are best combined or added to the existing portfolio of projects are those that have a negative (or low positive) correlation with existing projects.

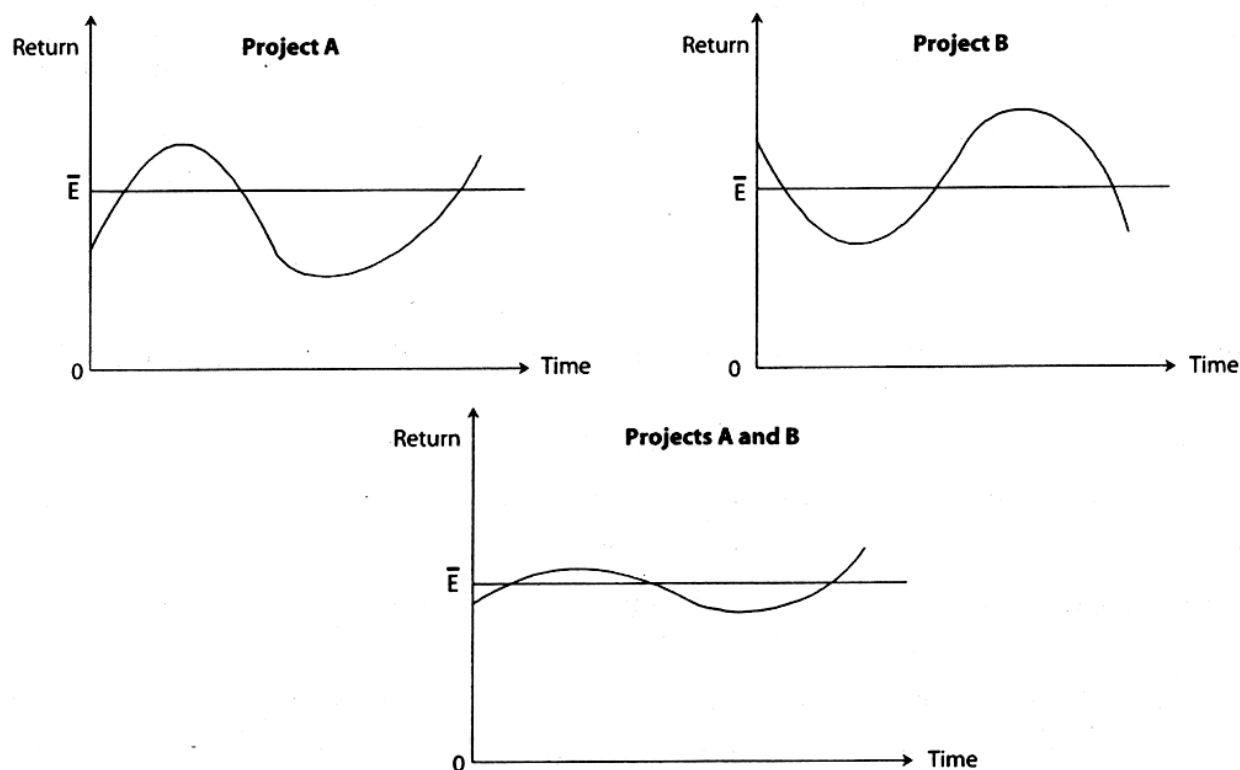

### Reduction of Risk through Diversification

By combining negatively correlated projects, the overall variability of returns or risk can be reduced. It shows that a portfolio containing the negatively correlated projects A and B, both having the same expected return,  $E$ , also has the return  $E$ , but less risk (i.e., less variability of return) than either of the projects taken separately. This type of risk is sometimes described as diversifiable or alpha risk. The creation of a portfolio by combining two perfectly correlated projects cannot reduce the portfolio's overall risk below the risk of the least risky project, while the creation of a portfolio combining two projects that are perfectly negatively correlated can reduce the portfolio's total risk to a level below that of either of the component projects, which in certain situations may be zero. Combining projects with correlations falling between perfect positive correlation (i.e., a correlation coefficient of +1) and perfect negative correlation (i.e., a correlation coefficient of -1), can therefore reduce the overall risk of a portfolio.

### Benefits of Diversification

The gains in risk reduction from portfolio diversification depend inversely upon the extent to which the returns on securities in a portfolio are positively correlated. Ideally the securities should display negative correlation. This implies that if a pair of securities has a negative correlation of returns, then in circumstances where one of the securities is performing badly the other is likely to be doing well and vice versa in reverse circumstances. Therefore the 'average' return on holding the two securities is likely to be much 'safer' than investing in one of them alone.

#### 8.1.4.3 Total Loss Distribution

Probability distributions can be very useful tools for evaluating the expected frequency and/or severity of losses due to identified risks. In risk management, two types of probability distribution are used: empirical and theoretical. To form an empirical probability distribution, the risk manager actually observes the events that occur, as explained in the previous section. To create a theoretical probability distribution, a mathematical formula is used. To effectively use such distributions, the risk manager must

be reasonably confident that the distribution of the firm's losses is similar to the theoretical distribution chosen.

Three theoretical probability distributions that are widely used in risk management are: the binomial, normal, and poisson.

#### 8.1.4.4 Probability of Ruin

Ruin theory also known as collective risk theory, was actually developed by the insurance industry for studying the insurers vulnerability to insolvency using mathematical modeling. It is based on the derivation of many ruin-related measures and quantities and specifically includes the probability of ultimate ruin. This can be also related to the sphere of applied probability as the techniques used in the ruin theory as fundamentally arising out of stochastic processes. Many problems in ruin theory relate to real-life actuarial studies but the mathematical aspects of ruin theory have really been of interest to actuarial scientists and other business research people.

Normally an insurers' surplus has been computed as the net of two opposing cash flows, namely, cash inflow of premium income collected continuously at the rate of  $c$  and the cash outflow due to a series of insurance claims that are mutually independent and identically distributed with a common distribution function  $P(y)$ . The path of the series of claims is assumed to respond to a Poisson process with intensity rate  $\lambda$  which would mean that the number of claims received  $N(t)$  at a time frame of  $t$  is controlled by a Poisson distribution with a mean  $\lambda t$ . Therefore, the insurer's surplus at any time  $t$  is represented by the following-formula:

$$X(t) = x + ct - \sum_{i=0}^{N(t)} Y_i$$

where, the business of the insurer starts with an initial level of surplus capital.

$X(0) = x$  under probability measure as explained in the previous paragraph.

Towards the end of the 20th century, Garbur and Shiu introduced the concept of the expected discounted penalty function derived from the probability of ultimate ruin. This concept was utilized to gauge the behaviour of insurer's surplus using the following formula:

$$m(x) E^x \mathbb{E}^{\partial} K_T$$

where,  $\partial$  is the discounting force of interest,  $K_T$  is a general penalty function representing the economic costs of the insurer at the time of ruin and the expectation relates to the probability measure. Quite a few ruin-related quantities fall into the category of the expected discounted penalty function.

In short, this theory of the probability of ruin is applied in the case of risk of insolvency of a company with diversified business activity. For the purpose of study, resources between diversified activities are allowed to be transferred and are limited by costs of transaction. Terminal insolvency happens when capital transfers between the business lines are not able to compensate the negative positions. Actuarial calculations are involved in the determination of ultimate ruin as discussed.

#### 8.1.5 Risk Analysis - Risk Mapping and Key Risk Indicator

Risk analysis is a procedure to identify threats & vulnerabilities, analyze them to ascertain the exposures, and highlight how the impact can be eliminated or reduced. In other words, risk analysis refers to the uncertainty of forecasted future cash flows streams, variance of portfolio/stock returns, statistical analysis to determine the probability of a project's success or failure, and possible future economic states. Risk analysts often work in tandem with forecasting professionals to minimize future negative unforeseen effects.

##### 8.1.5.1 Risk MAPPING

Risk mapping is the first step in operational risk measurement, since it requires identifying all potential risks to which the bank is exposed and then pointing out those on which attention and monitoring

should be focused given their current or potential future relevance for the bank, while the risk mapping process is sometimes identified with the usual classification of operational risks in a simple frequency/severity matrix, what is really needed to map banks' internal processes in order to understand what could go wrong, where, and why, to set the basis for assessing potential frequency and the severity of potential operational events, and to define a set of indicators that can anticipate problems based on the evolution of the external and internal environments. Careful risk mapping is an important as a first step for operational risk measurement as it is for the audit process, when potential pitfalls have to be identified in advance and properly eliminated or at least monitored. risk mapping should start from process mapping and from identifying critical risks in each process phase, linked either to key people, to systems, to interdependencies with external players, or to any other resource involved in the process. Subsequently, potential effects of errors, failures or improper behavior should be analyzed. This may also lead to identifying priorities in terms of control actions. Of course, special care should be given to high-severity risks, even if they appear unlikely to occur.

Risks are unanticipated events that may affect the organization's ability to meet its key objectives. These could consist of unfavorable situations or missed opportunities. As such, a clear and effective understanding of the major risks is a key driver for organizational success.

Risk mapping is the process of identifying, quantifying and prioritizing the risks that may interfere with the achievement of your organizational objectives.

Its aim is to arrive at a clear set of action plans that improve risk management controls, in areas where these are necessary and help the management of the organization's direct resources.

### Risk Mapping Defined

A risk map is a graphical depiction of a select number of a company's risks designed to (1) illustrate the *impact or significance* of risk on one axis, and (2) the *likelihood or frequency* on the other axis. Many types and variations of risk maps exist. For example, the axes can vary (impact and likelihood on different axes), the scales can vary, and some are even three-dimensional. The following example in the below Figure 1 illustrates a typical risk map.

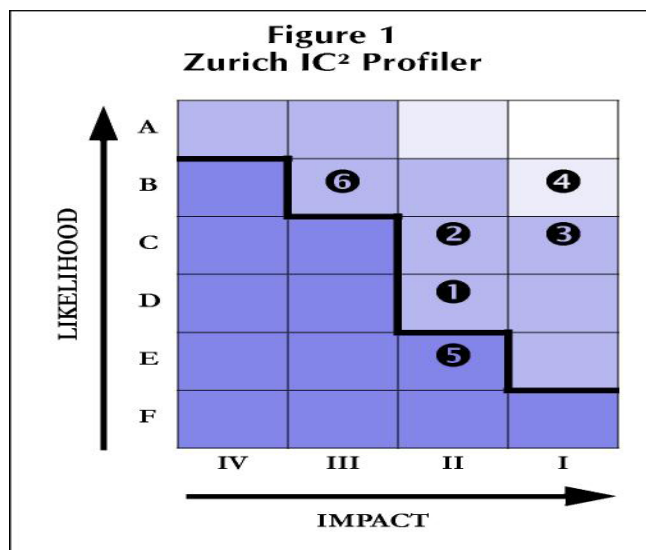

This risk map depicts likelihood or frequency on the vertical axis, and impact or significance on the horizontal axis. In this configuration, similar to that of a mathematical distribution curve, likelihood increases as you move up the vertical axis, and impact increases from left to right.

The points on the profile represent risks that have been categorized into four *impact* categories and six *likelihood* categories. The categories simplify the prioritization process by forcing placement of each risk into



a particular box showing its position relative to the others. The “stepped” line is the *Critical Issue Tolerance Boundary*. Scenarios or risks above this boundary are considered intolerable and require immediate attention, while risks below the boundary do not require immediate attention.

The methodologies used to develop risk maps are as varied as the different risk map types. We will summarize one such process.

### **Risk Mapping Process**

The risk mapping process is part of a systematic, comprehensive methodology to identify, prioritize, and quantify (at a macro level) risks to an organization. This example of the mapping process is taken from the Zurich IC<sup>2</sup> Profiling process, a methodology that entails a facilitation session and application of proprietary software to capture information. Other methods of capturing information include structured interviews, surveys (written and electronic) or a combination of these. Individual client characteristics and needs dictate the appropriate method of data collection.

We will describe the facilitation risk profiling process by highlighting the major elements. These include the workshop, scope, team composition, time horizon, scenario development and categorization, tolerance boundary, profile development, action plan, process and technology transfer, and quantification and modeling.

### **Scope**

The scope of the exercise is determined at the beginning of the analysis to specify the areas of the business considered. The scope provides the parameters for the analysis. Scope is often defined as identifying, prioritizing, and understanding risks and impediments to achieving corporate and strategic objectives. The scope can be as broad or as narrow as desired; however, a balance exists between the breadth of scope and the value of information derived from the risk mapping process. For example, the value of one risk map for a multi-billion dollar firm would be significantly less than one risk map for each division or business unit of that company. We will address different scope options later in this article.

### **Benefits of risk mapping**

- Promotes awareness of significant risks through priority ranking, facilitating the efficient planning of resources.
- Enables the delivery of solutions and services across the entire risk management value chain.
- Serves as a powerful aid to strategic business planning.
- Aids the development of an action plan for the effective management of significant risks.
- Assigns clear responsibilities to individuals for the management of particular risk areas.
- Provides an opportunity to leverage risk management as a competitive advantage.
- Facilitates the development of a strategic approach to insurance programme design.
- Supports the design of the client's risk financing and insurance programmes, through the development of effective/optimal retention levels and scope of coverage etc.

#### **8.1.5.2 Key Risk Indicator**

Key risk indicators come out as the result of the mapping process and should be used to provide anticipatory signals that can be useful for both operational risk prevention and measurement. In particular, they should provide early warning signals to anticipate the most critical operational events, and they may also be partly derived from the experience of audit departments defining potential risk scores for different business units as a tool for defining priorities in their audit action plan.

1. Process mapping

2. Identification of key risks in each process phase

3a. Definition of Key risk indicators

3b. Potential impact and identification of priorities for action

1. The definition of the operational events that should be captured by the data base.
2. The minimum threshold of loss to be recorded
3. The classification criteria that should be applied to operational events
4. The way in which loss should be recorded
5. The architecture of the loss collection process
6. The policies concerning operational events' internal disclosure.

As far as the definition of an operational event is concerned, the bank should first decide whether to adopt a stricter definition of operational losses or whether also to record other kinds of events that might be relevant for internal operational risk management purposes. One example is represented by credit losses deriving from operational errors (e.g. missing documentation, making it impossible to take advantage of collateral in a case of default, or human error in handling a loan review process, resulting in missing the chance to take appropriate actions to reduce exposure with a borrower that will eventually default). According to Basel Committee 2006a those losses are already taken into consideration under credit risk MRCR, and hence, correctly, they should be excluded from the operational risk loss data base to prevent double counting. Yet measuring the frequency and severity of these events may be useful for internal purposes, to understand the relevance of the phenomenon and to support remedial actions.

The second issue is to whether also to record the so-called near misses, i.e. those events that might have provoked operational losses even if they (luckily) did not. an example of a near miss is a mistake in recording a trading deal that generated an accidental gain instead of loss. while the severity of such events is clearly zero, their frequency and type may be relevant for providing further data about what could have happened and as useful signals to business line managers who should take these events as a relevant warning signal. Cases of operational error implying faulty profit allocation across business units (e.g. due to an incorrect internal deal transcription, which did not affect overall bank profit) could be placed in this category. A bank may therefore adopt a broader definition of operational event than Basel II suggests, while it should still use a subset of data only when estimating AMA- compliant operational risk capita

The threshold over which losses should be recorded ( with potential exception of near misses) is a particularly critical choice for risk quantification. Intuitively, if the threshold were too high, only a relatively limited number of medium- to high-impact events would be recorded, provided a weaker base for estimating the frequency and severity of all operational events. A lower threshold allows one to model operational risk severity and frequency better but also implies higher collection costs. moreover, lower threshold require greater effort to enforce the rules of the loss collection process at the bankwide level. in fact, larger operational losses cannot clearly be either hidden or forgotten. yet, as the threshold decreases, the risk of incomplete reporting of operational loss in some business units increases, and great care is required to avoid alterations of data quality( with the likely effect of underestimating frequency and overestimating average severity of losses).

## 8.2 CORPORATE RISK MANAGEMENT

Corporate Risk Management works to ensure the safety of the business, guarding it from risk of injury or financial loss. It helps to optimize risk taking of an organization.

### **Management of Strategic Operational Risks**

The process of risk identification and assessment followed by Tata Chemicals Limited (TCL) is dynamic in nature. Hence the company has been able to identify, monitor, and mitigate the most relevant strategic and operational risks both during its periods of accelerated growth and during the recessionary phase of the economy (2008-09).

Identified risks are used as an input while developing strategy and business plans. The risk management framework at TCL encompasses the following activities:

#### **Risk identification**

A periodic assessment across various variables and the subsidiaries of a company, with a trigger-based assessment, is undertaken to identify and thereafter prioritize significant risks. This assessment is based on an online risk perception survey, environment scanning, and inputs from key stakeholders.

#### **Risk measurement and control**

Professionals at all levels who are responsible for managing risk are identified as 'owners'. Owners are identified for all identified risks and they go on to develop and deploy mitigation strategies. Measurement indices are used to evaluate the effectiveness of these mitigation plans.

#### **Risk reporting and review**

Besides a detailed review by the executive committee, enterprise risks are reviewed quarterly by the audit committee of the board. Risk owners present status updates on their mitigation plans in front of the committee. Some of the major risks and concerns that TCL has identified are as follows:

#### **Continued recessionary pressure**

Although world markets and economies have begun to recover from the unprecedented turmoil witnessed during 2008-09 reduced consumer wealth and consequent demand continue to be major concerns. Additionally, the withdrawal of fiscal stimulus packages across the globe further accentuates this risk. While the breadth of TCL's portfolio and its geographic spread has helped mitigate the crisis to an extent, it continues to protect its profits through a new wave of enterprise wide initiatives on cost compression.

#### **Financial risks**

Tata Chemicals Limited's breadth in international operations, India's foreign currency borrowings, and India's dependency on imports for the phosphate fertilizers, continue to subject the company to risks from changes in the relative value of currencies. The company's elaborate treasury policy ensures that foreign exchange exposures are within prescribed limits and the use of foreign exchange forward contracts is resorted to judiciously. The company has a separate risk management committee that monitors and helps mitigate our currency and interest rate risks.

#### **Government subsidy on sale of fertilizers**

Effective as of 1 April 2010, the Government has introduced a nutrient-based subsidy for phosphate and potash-based fertilizers. This change can result in margin pressures in the short/medium term. Uncertainty regarding the timing of receipts of Government subsidy in the fertilizer business is a major factor affecting cash flows and hence working capital requirements. Here again, the company's treasury policy anticipates this risk and adequate precautions have been built in to address the issue.



## Input costs and securitization of raw materials for fertilizer business

The prices of raw materials for phosphate fertilizers are subject to economic conditions and global demand-supply balances. With the change in policy towards subsidy grants based on the nutrient, it is imperative that the prices of imported raw materials be competitive. While TCL has entered into a long-term supply contract for its key raw materials, the pricing of these are normally formula based. TCL actively monitors the environment for fresh opportunities and maintains good supplier relationships to ensure minimal impact from commodity price fluctuations.

## People and talent

Attracting and retaining talented employees is core to the company's success. Tata Chemicals Limited has, over the years, embarked on several 'people initiatives' to enhance the environment and help employees achieve their personal and professional goals. Work-life balance is consciously pursued. The company's performance appraisal systems are well-integrated with its business objectives as well and help bring out the best in individuals. Investment in employees through training is constantly made to ensure that TCL equips its employees for challenges in their roles.

## Safety and environment-related risks

Tata Chemicals Limited is conscious of its strong corporate reputation and the positive role it can play by focusing on social and environmental issues. Towards this, the company has set very exacting standards in safety, ethics, and environmental management. It continues to recognize the importance of safety and environmental issues in operations and has established comprehensive indicators to track performance in these areas. The company values the safety of its employees and constantly raises the bar in ensuring a safe work place.

The company continues to benchmark its internal audit and risk management practices with the global best and ensures that high standards are set to meet the challenges of the external environment.

## Relationship between Risk and Strategy

Business process management in itself involves both short-term and long-term decisions. An entrepreneur who promotes a business entity is aware of the risks that he will encounter during the period of incorporating the entity, establishing infrastructure, and entering commercial operations in a time bound framework.

The entrepreneur tries to formulate a corporate strategy, and then implement, evaluate, and control it to attain the desired goals. In today's volatile economy, it is difficult to make corporate strategy work in a designated manner. Normally, corporate strategy risk identification has three steps. These are as follows:

- (1) Looking inwards to comprehend the organizational mindset and its operations.
- (2) Understanding the external environment, especially, in respect to competition at the market place and the political, social, and cultural issues that impact corporate strategy.
- (3) Combining steps 1 and 2, projecting the requirements of the strategy and identifying the grey areas, that is, risks.

Maintaining the balance between the internal and external environments is vital; this process includes several risks, and maintaining this balance may itself become a challenge.

Previously we had identified risk in the traditional sense as different from uncertainty and characterized it at the macro level. These risks put on a different garb when projected into the future in long-term planning for strategy. To summarize the impact of identified risk on a strategic exercise, the following observations can be pointers:

**Country risk:** This type of political risk is one area of concern whenever a business is started in a foreign country. Political risk encompasses all undertakings in some form or another, susceptible to the influence

of state control. This can be either in the form of controls on raw materials, licensing, or pricing, as well as on any issue that may be of public importance arising from the company's activity.

Political risk is also caused by changes occasioned by political influence rather than the company's influence. This is particularly important as corporate strategy should be flexible enough to absorb the shocks caused by political influence over a period of time.

For instance, nationalization was adopted by many socialistic Governments at some point in time, and then reversed due to the exigencies of a market economy. Again, Government interference and interventions in the Indian corporate sector have wielded distinct influence on the courses of strategy pursued by companies. This is especially true in the case of a public sector company. Multinational corporations have also developed their own political lobbies to mould Governmental policies in such a way that the alignment of corporate strategy with government directives principles is not compromised.

**Market volatility:** This has always rendered a long-term strategy susceptible to deviation from the desired course. Markets are no longer protected and the whole world has shrunk due to new vistas in communication. The winds of change that have been blowing across the globe during the last few decades have brought in many abrupt changes resulting in the diverse business risks of demand-supply imbalances, divergence, unexpected technological obsolescence, and new exigencies in corporate governance. The price mechanism has also changed. The belief that price takes care of all the factors of production such as land, labour, capital, technology, and enterprise, is not too correct because inefficiencies in any of the factors cannot be passed on to the customer. Customer behaviour, an important component of the value chain, needs to be carefully coordinated. However, the parameter is itself unpredictable, since customer perceptions across segments and sectors are known to vary and thus add to the risk component.

**Human aspects of corporate strategy:** These continue to be enigmas in the course of corporate history. From the time of the Industrial Revolution until today, many vicissitudes and changes have been observed in the relationship between labour and management. The birth of trade unionism and collective bargaining as a source of strength for labour has also introduced a sea change in labour management thought. Political parties have made inroads into labour movements and their influence has not been appreciated. An increase in unlawful activities by intransigent labour unions has also led to risks in developing strategies that are an amalgam of both bottom-up and top-down approaches.

Different ideologies have also shaped the ways of work as they spread across different countries.

The application of turnaround strategies, restructuring, business process reengineering and the like have faced many risks, in terms of the human component while facing issues such as cutting out dead wood, developing safety nets for retiring employees, and retraining existing employees to help them gain new skills.

Human resources problems, such as resistance to technology upgrades that would cause job losses, affect the course of a corporate strategy due to both external and internal risks arising out of political, technological, and ideological changes. For example, there was a challenge in India with respect to adoption of technology in banks and public sector units when IT was introduced as it required training and loss of some job opportunities.

**Geo-politics at an international level:** This refers to risks arising from geographical differences. This type of risk, such as the current Middle East crisis, may have a cataclysmic impact on corporate strategy. This is also seen in cases where developed countries wield a lot of influence on the developing or the less developed countries with regard to moulding their corporate strategies. Economic power has also been shifting from the west to the east as developed countries have production capacities in excess of their demand due to stagnating populations and high cost economies. The scramble in new markets for products from developed countries in the developing world has also introduced a misalignment due to the diverging aims of various nations.

Due to the presence of greed in particular sections of the business community, it is said that geopolitics has introduced some new types of risks. Their actions culminate in the bankruptcy of companies leading to failures of big banking institutions. Although it is difficult to spell out all instances, examples of some crude oil resource-dominated countries and parts of Europe and Africa demonstrate this type of political risk. These violent occurrences have had repercussions on the market economy, leading to recessions and then to depressions. These sudden changes have also introduced uneven parities among currencies, liquidity crunches, and lop sided international trade.

The impact of these four factors can be identified as specific risks as follows:

**Risks affecting capital influx:** Capital formation through foreign direct investment must face the ramifications of political risk at the strategic level. Policies favouring capital influx into a country may have to toil against policies favouring nationalization or stringent governmental controls, especially due to the usually long time-frame of their eventual implementation. Influx of capital through foreign institutional investments must also face different risks caused by changes in interest rate, political, and national exigencies.

For example, the different interest rates in different countries has introduced a risk, in that FII's pull out of a country or enter another country in a big way, leading to volatility in interest rates and their differentials. A thin margin of profit may lead to an avalanche of foreign institutional investors moving from one country to another. For instance, an increase in foreign institutional investment in some Asian economies, such as India, towards the end of the 20th century occurred when the Asian tigers suffered a jolt in their economy.

Another important risk in this arena is the camouflage of investments through participatory notes and the like. This may obscure the likely participation, in the secondary market, of groups that may have links with terrorism and the mafia.

**Risks affecting global governance:** Capital flows represent only one aspect of international trade. To build international trade on global governance norms is a must. However, it is easier said than done. Global governance rests not only on economic criteria but also on the kaleidoscope of different national aspirations, social and commercial networks, and the barriers that face their integration. These barriers arise from fears held by every nation that their own interest may be jeopardized in the maze of international negotiations. This is amply clear from the number of conferences held during the last ten years, under the aegis of the World Trade Organization (WTO). While the laudable objective is to develop a level playing field in which the developed, developing, and underdeveloped countries play fairly according to the rules of the game. The risks that lurk in developing global governance are as follows:

- (1) Conflicts in the aspirations of the different nations
- (2) Volatility in the political affiliations
- (3) A yawning gap in the balance of payment positions between developed countries and the rest of the world.

These risks are aggravated by the emergence of fast-developing economies such as China, India, and other Asian nations which introduce more complexity in a negotiating framework that is acceptable to all countries under the sponsorship of the WTO.

The progress made on some of the key issues discussed at the fourth WTO ministerial summit at Doha are summarized below:

The fourth ministerial meeting of the World Trade Organization (WTO) was held in Doha, Qatar, in November 2001. The previous meeting of the WTO that was held in Seattle failed to launch a new round of trade negotiations. This led to significant pressure, particularly on the part of developed country Governments, to ensure that the summit at Doha succeeded in mapping the directions of future trade negotiations.

The following is the summary of the progress made on some of the key trade-related development issues discussed at the fourth WTO ministerial summit in Doha, from the Australian Council for Overseas Aid's (ACFOA) point of view:

### **Agriculture**

A number of developing countries were keen to strengthen special and differential options to support poor farmers especially to ensure food security at the time of crises. In principle, it requires a clear action plan based on specific measures so that outcomes can be predicted.

### **Technical assistance**

Developing countries were disappointed with the Harbinson text in that while the rhetoric was fine, there was little by way of compulsion and timings that would force WTO members to deliver further on trade-related technical assistance and capacity building for the poorer members.

There was a need for a three-pronged approach to trade-related development problems of less developed countries (LDCs). Market access was of little avail if there was little to competitively export. Supply side solutions were necessary to help develop infrastructure, goods and services for export as well as the need for technology transfer, human resource development, and support for implementation of WTO rules. However, developed nations showed a reluctance to increase aid budgets and additional assistance to developing nations does not look like a possible way forward.

### **Trips**

Developing nations wanted greater access to medicines and protection from the ability of transnational companies (TNCs) to buy patents on genes and seeds, etc. of the 900 patents on seeds, 44 per cent are owned by just four TNCs. This hurts developing countries by way of cost and availability. For example, when farmers pay high prices for seeds, it spirals up their input price and basic food crops become more expensive to produce and sell.

The US and Brazil made some progress on a compromise on access to medicines that would give comfort to those in need of more affordable and accessible medicines. However, the issue of patents on seeds and genes was not addressed.

### **Environment**

Developing countries were not happy with the EU's position on the precautionary principle as this was mainly used for protectionist measures.

Less developed countries in particular were vastly outnumbered and understaffed in dealing with the complexity of negotiations compared with delegations from developed countries. There are still problems of transparency and capacity that LDCs find difficult. They often lack the legal expertise or the clout to attend meetings and determine complex trade policy positions in their favour. Nevertheless, developing countries did work well together as a block on some key issues and managed to counter some of the political pressure brought to bear by the US and EU. Many development NGOs have worked very hard in supporting developing country delegations in the formulation of policy positions in the absence of any other support.

While the last decade has thrown up many factors that seemingly provide a healthy compromise for integrated global governance, they have also raised many contradictions. This paradox is due to the fractured relations between different political entities that are homogeneous for a period, and then suddenly become heterogeneous. Even though every country professes that protectionism has to be abjured to arrive at a consensual approach to a well-structured world economy in the short term, national interest supersedes the long-term interest of the community of nations.

Although the colonialism that typified the 18th and 19th centuries has disappeared, neocolonialism has reappeared in a different form through economic exploitation. Thus, the path of global governance needs to be managed with a sensitive and sensible approach.



**Risk due to differing business conditions:** Business transactions in various countries are governed by national statutes, and the economic, social, and cultural outlook of the people of the country. There are countries where each business transaction is well-documented and a legal entity is available. However, in certain other countries, business is still consummated through word of mouth and there is very little documentation. Apart from these factors, the emergence of information technology (IT) has assured policy makers that there is a certain dynamism and urgency in all transactions. Herein too lies a risk, as many countries are yet to adapt to the fast-growing and wide-reaching effects of IT. Different levels of comprehension and usage and the phenomenal growth of 'tech business' have also introduced both commercial and political risks.

The phenomena of business process outsourcing, the mushrooming of the call centre culture, and knowledge process outsourcing, both onshore and offshore, have also added to the risk of unemployment in developed countries, where jobs may be sacrificed at the altar of cost reduction. Besides, the barriers of language across different nations have led to complexity in many negotiations. English speaking countries have been able to fare better while negotiating business contracts, but countries that are not so familiar with the language have also managed to capture centre stage through political will and power.

While developed countries have the necessary infrastructure for production, they do not have the necessary demand within their own country due to a stagnant population. On the other hand, in developing countries, the level of infrastructure available is not able to match the pace of economic development. As such, there is a gap in meeting the demands of the developing countries for the products required by them. In a similar manner, logistics have not sufficiently improved in many developing countries to handle the huge import of goods from developed countries. These anomalies have introduced trade risk in the form of failure to meet deadlines, failure in quality and failure in completing transactions. Such risks again need to be addressed by a well thought-out specific approach by each country.

### **8.2.2 Risk Retention**

This denotes acceptance of the loss or benefit arising out of a risk when it takes place. In short, it is also termed as self insurance. This strategy is viable when the risks are small enough to be transferred at a cost that may be higher than the loss arising out of the risk itself. On the other hand, the risk can be so big that it cannot be transferred or insured. Such risks will have to be phased out when the eventuality occurs. War is an example as also are 'Acts of God' such as earthquakes and floods. The reasons for risk retention can be cited as follows:

- (1) While risk in a business is taken to increase its return, risk retention relates to such risks which have no relation to return but are part of an individual's life or organization or a company operational risk can be cited as such a risk that is inherent and needs to be accepted for retention.
- (2) Sometimes, such risks are so small that they are ignored and/or phased out when they surface.
- (3) This method is also useful when the probability of occurrence is very low and a reserve built within the system over a period can take care of such losses arising out of risk retention. This is normally resorted to in businesses against credit risks that are inherent due to marketing on credit basis.
- (4) In some cases, the subject, who is susceptible to risk, also becomes fully aware of the nature of risk. In these situations, there is a certain amount of preparedness in the system due to risk retention.

#### **Certain guidelines relating to risk retention should be followed:**

- (1) Determine the risk retention level through proper estimation of risk using sales projections, cash flows, contracts, liquidated damages, and guarantees.
- (2) Though there is no precise formula for estimation of risks to be retained, statistical averages of such losses over a period of time give an indication to estimate such losses. For instance, bad debts



occurring over a period of time are taken into consideration as an estimate to create a reserve for doubtful debts.

- (3) It is also necessary to ascertain the capacity for funding a loss arising out of retained risk that is the measure for transferring the risk beyond that level.

Risk retention as an exercise and a strategy is attempted mainly in the case of operational risk in business.

### **8.2.3 Risk Reduction**

Risk reduction or optimization aims at reduction in the severity of laws or the probability that laws may not be passed. While risks can be helpful or harmful, optimization leads to a balance between negative risk and the advantages of the operation. Risk reduction can also be termed as mitigation that would include all measures taken to reduce the effect of the hazard itself as well as the vulnerable conditions leading to the hazard. Risk reduction also includes steps to mitigate physical, economic, and social vulnerability.

The mitigation carried out is such that there should be an ultimate reduction in the loss due to a hazard. Sometimes certain steps taken to mitigate a hazard may turn out to be more damaging, as in the case of certain fire suppression systems. The cost of such steps is so prohibitive that the losses cannot be reduced intrinsically. Outsourcing can be considered an act of risk reduction if the vendor has the expertise and a higher capability in mitigating risk. For example, demolition of an old, risky, high-rise building could be outsourced to an expert vendor who could implode the building without causing any damage to the environment or people.

Risk mitigation also implies a certain extent of preparedness on the part of the risk bearer because he is aware of the risk. This helps identify the parameters that lead to the disaster and mitigate parameters ahead of the eventuality, thus reducing the risk. Studies based on HAZOP are known to help factories develop sufficient preparedness in case of a hazard or explosion. It is sometimes known as 'failsafe' activity. For example, the introduction of a rupture disc in the pressure equipment as a failsafe against excessive pressure buildup. The rupture disc saves the equipment when the actual risk takes place by blowing out the contents or by reducing the pressure.

In case of physical disasters, detailed disaster management preparedness is a plan for mitigation. These mitigation measures can be either structural or non-structural and can also be described as passive or active. The passive approach can be code of conduct and training to personnel who may have to face a risk while active measures actually rely on providing incentives for disaster reduction.

Mitigation embraces all measures taken to reduce both the effect of the hazard itself and the conditions vulnerable to it, in order to reduce the scale of a future disaster and its impacts. Mitigation also includes measures aimed at reducing physical, economic, and social vulnerability. Therefore, mitigation may incorporate community-related issues such as land ownership distribution. Depending on their purpose, mitigation measures can be categorized as structural or non-structural.

Both structural and non-structural mitigation measures may be termed either 'passive' or 'active'. Active measures are those that rely on providing incentives for disaster reduction. They are often more effective than passive measures, which are based on laws and controls. For example, while codes and land use planning may provide a legal context for mitigation, they are ineffective unless rigorously enforced. Instead, measures that provide incentives such as Government grants or subsidies, reduction in insurance premiums for safer construction and provision of Government technical advice are more effective. Structural mitigation measures relate to those activities and decision making systems that provide the context within which disaster management and planning operates. They are organized and include measures such as preparation of preparedness plans, training and education, public education, evacuation planning, institution building, warning systems, and land use planning.

The existence of a disaster-preparedness plan is the foremost step of importance. Distraught officials have at hand a set of instructions that they can follow to issue directions to their subordinates and

affected people. This speeds up the rescue and relief operations and boosts the morale of victims. Disaster plans are also useful for pre-disaster operations, when warnings have been issued. Time, which might otherwise be lost in consultations with senior officers and getting formal approval, is saved. Response plans are formulated by different agencies that need to co-ordinate during emergencies. For example, the electricity board would be responsible for preparing an action plan, which would be used following a disaster event to restore full services quickly. A Contingency Action Plan (CAP) already exists at the national level that lists out in detail the actions to be taken in various levels of Government at the time of calamity. There is, however, a need to carry out a comprehensive revision of CAP followed by clear-cut operational guidelines. Recently, a high power committee has been established to prepare a disaster management plant at central/state and district levels

### **Mitigation strategy**

The plans recognize the fact that effective community involvement and public awareness can largely minimize the impact of disasters. The community-based mitigation strategy strengthens and stabilizes the efforts of the administration. The focus is on community capacity building including formation of Community Emergency Response Teams (CERT).

Mitigation strategy also focuses on micro-risk assessment and vulnerability analysis including hazard mapping, applied research and technology transfer to improve the quality of forecast and disseminate warnings quickly. It also highlights the need for a disaster management legislation and relief and rehabilitation policy that would define specific roles and responsibilities as well as set-up permanent administrative structures and institutional mechanisms for disaster management. The importance of land use planning and regulations for sustainable development, which include development and implementation of building codes, serve as a guideline to managing disaster. Structural and non-structural measures, given in the mitigation strategy document, are used to avoid damages during disasters.

### **Training strategy**

Training of the key community and social functionaries is an essential element for the successful execution of a Disaster Management Action Plan. The DMAP cannot be fully operationalized without keeping in mind a training strategy, manuals for warning and evacuation, and the roles of the Emergency Operations Center (EOC), and District Control Room (DCR). The manuals list the tasks to be undertaken by the responsible branch authority. Information on important contact persons and emergency officials is also provided in the manual. The state and the district plans specify guidelines for the community as well as NGOs and local community based organizations in the advent of any disaster.

### **Community-based preparedness strategy**

For calculated response in case of a disaster, a plan for community preparedness is essential. The plan must incorporate the following points:

- Clearly perceived vision of hazards and developed hazard profile of the community and its neighbourhoods.
- Assessment of risk and its vulnerability.
- Identification of individual and community resources.
- Must be clear and simple, specific in details, define duties and responsibilities of each member, ear-mark various escape routes, and locate shelter sites.
- Written as a simple concise 'checklist' so that one does not have to refer to it in depth when emergency arises.
- The Panchayat/local body/local community forms resilient focal communities or target groups.

This, however, is possible only with the concerted efforts and conscious policy at top level of administration.

### **Geographic Information System (GIS)**

Disaster planning involves predicting the risk of natural hazard and possible impact. The use of GIS can be successfully made in communication, risk and vulnerability assessment, study of loss patterns, and searches. Hazard maps could be created for cities, districts, states or even for the entire country. Such maps prove helpful for analysis and determination of hazard zones and for the likely effects during disasters. The maps can be successfully used in establishing response priorities, developing actions plans, quickly assessing disaster location, carrying out search and rescue operations effectively, and zoning operations accordingly to risk magnitudes, population details, and assets at risk. Geographic Information Systems (GIS) and remote sensing facilitate record-keeping and obtainment of status or ongoing works that are the most critical task for disaster management.

### **8.2.4 Asset Liability Management Model**

Risks encountered in portfolio management need to be addressed more emphatically. In passive portfolio management, normally the mean variance and mean absolute deviation are employed to arrive at an optimal fixed mix strategy. However, this method does not recognize the high volatility in financial markets and as such the volatility risk is not addressed. However, active portfolio management is more aggressive, and involves reviewing the initial investment strategy every time rebalancing of the portfolio is required. Carino and Turner (1998) present the superiority of dynamic asset allocation framework using stochastic programming applications. Any financial planning strategy should be such that the mix of asset classes in a portfolio is able to grow and satisfy future goals with the best possible returns. This is the crux of asset liability management.

Asset liability management applications with the aid of stochastic programming conceptualize the problem of creating a portfolio by allocating a set of assets. The investor needs to decide the three factors, namely:

- Amount of assets to buy
- Amount of assets to sell
- Amount of assets to hold

The indices are defined and the problem parameters and decision variables are set out so that the stochastic programming model can develop a solution.

In this deterministic model, uncertainty is introduced to take care of risk. A refinement to the deterministic model is to apply a more sophisticated technique for estimation of asset prices that takes into consideration any unusual occurrence in the market as well as volatility. Sub-models based on randomness are introduced into the programming to take care of the risk as well. The randomness introduced is able to generate a set of scenarios which can be incorporated into the optimization model.

This model can be further improved using a two-stage stochastic program because an investor tries to use this model for making a contingent decision involving future risk. The first stage involves fixing a time period for stage two observation followed by finally taking a decision. The observation part of it can be likened to a 'wait and see' period of observation.

Asset liability management model can also be conceptualized as a method to compute the matching of assets and liabilities to generate a cautious investment portfolio. The purpose of this model is to optimize risk-adjusted returns to the shareholders over a long run. Two approaches for matching assets and liabilities are as follows:

**Duration:** This is defined as a measure of price sensitivity in relation to interest rates. It refers to the

weighted average maturity where the weights are applied in terms of present value. This can be represented by the following formula:

Modified duration = Duration / [1 + (Yield to maturity/Number of coupon payments per year)]

**Convexity:** This is defined as the change in duration corresponding to changes in yield as follows:

$$\text{Convexity} = (P_+ + P_- - 2P_0) / 2P_0 ((\Delta i)^2)$$

where

$\Delta i$  = Change in yield (in decimals)

$P_0$  = Initial price

$P_+$  = Price if yields increase by  $\Delta i$

$P_-$  = Price if yields decline by  $\Delta i$

Combining convexity and duration is a good approach to examining the influence on change in yield on the market values of assets and liabilities.

The asset management model can also be employed to manage liquidity risk. Assets and liabilities can be arranged according to their maturity pattern in a time frame. Applying gap analysis, the differential between maturing assets and maturing liabilities are computed. If the gap is positive, then assets exceed liabilities; if it is negative, infusion of funds would be necessary either through sale of assets or creating new liabilities or a rollover of existing liabilities.

This model can also be applied to exchange rate risk management. Financial institutions match their assets and liabilities at a particular exchange rate. Fluctuations in the exchange rate obviously disturb the balance. This risk is corrected by matching the assets and liabilities in the same currency. The risk of foreign exchange borrowings can also be passed on to the lenders through foreign currency loans. The uncovered borrowings can be hedged through forward covers for the entire amount.

### 8.2.5 Project Risk Management

Projects are one time processes - unique in nature. Each project will be different and has different gestation periods. By its own nature, a project is based on many assumptions, to be realized at a future and is subjected to environmental changes and changes due to statutory policies. With a gestation period running into a few years, any change or revision in assumptions can transform itself into a big risk. Management of such risks is called 'Project Risk Management', which can be difficult and would require special tools and models.

#### Project Risk

This risk arises when a project fails to take off due to sudden and drastic changes in the base assumptions. A project exercise normally extends over a period of 5-10 years and the entire economics of the products is based on many assumptions. Where the assumptions had not been fully verified and tested, the projects came to grief. Especially in the case of an industry that pollutes the environment, the assumption that a company can get away with minimum treatment of the pollutant has proven to be disastrous.

The risk evaluation and its minimization is to be made for the projects which are going to be implemented. The application of risk management in new projects consists of the following steps:

- (a) Plan should include risk management tasks, responsibilities, activities and budget.
- (a) Assigning a Risk Officer, a team member other than a Project Manager, who is responsible for foreseeing potential project problems.
- (b) Maintaining live project risk data base. Each risk should have the following attributes: opening date, title, short description, probability and importance.

- (c) Creating anonymous risk reporting channels. Each team member should have possibility to report risk that he foresees in the project.
- (b) Preparing mitigation plans for risks that are chosen to be mitigated.
- (c) Summarize the planned and faced risks, effectiveness of mitigation activities and effort spend for the risk management.

Risk is the essence of entrepreneurship. In business the extent of risk varies with each investment. Enterprises should consciously consider the possibility of realizing the course and results of events as planned before venturing into their investments. Risks in project management are basically:

- (a) Market related risks - mainly due to changes in demand
- (b) Completion risks - due to both administrative and technical risks during implementation
- (c) Institutional risks - due to unexpected changes in the conditions and norms laid down by the institutions that have funded the projects.

All these three risks can create certain consequences of events, compounded by unforeseen circumstances. This may lead to 'turbulence', when multiple issues arise, initiating moves and counter moves and often ending in deadlock and the entire project may collapse.

### **8.2.6 Enterprise Risk Management**

The Enterprise Risk Management (ERM) is defined as "a process, effected by an entity's board of directors, management and other personnel, applied in strategy setting and across the enterprise, designed to identify potential events that may affect the entity, and manage risk to be within its risk appetite, to provide reasonable assurance regarding the achievement of entity objectives".

From the above definition, ERM is:

- (a) A process, ongoing and following through an entity.
- (b) Effected by people at every level of an organization.
- (c) Applied in strategy-setting.
- (d) Applied across the enterprise, at every level and unit, and includes taking an entity-level portfolio view of risk.
- (e) Designed to identify potential events affecting the entity and manage risk within its risk appetite.
- (f) Able to provide reasonable assurance to an entity's management and board.
- (g) Geared to the achievement of objectives in one or more separate but overlapping categories.

ERM is about designing and implementing capabilities for managing the risks that matter. The greater the gaps in the current state and the desired future state of the organizations risk management capabilities, the greater the need for ERM infrastructure to facilitate the advancement of risk management capabilities overtime. ERM is about establishing the oversight, control and discipline to drive continuous improvement of an entity's risk management capabilities in a changing operating environment.

ERM deals with risk and opportunities affecting value creation or preservation. ERM is a comprehensive and integrated approach to addressing corporate risk. ERM enables management to effectively deal with uncertainty and associated risk and opportunity, enhancing the capacity to build value. In ERM, a risk is defined as a possible event or circumstance that can have negative influences on the enterprise in question. Its impact can be on the very existence, the resources (human and capital), the products and services, or the customers of the enterprise, as well as external impacts on society, markets or the environment.

## Need for Implementation of ERM

ERM needs to be implemented for the following reasons:

- (a) Reduce unacceptable performance variability.
- (b) Align and integrate varying views of risk management.
- (c) Build confidence of investment community and stakeholders.
- (d) Enhance corporate governance.
- (e) Successfully respond to a changing business environment.
- (f) Align strategy and corporate culture.

Traditional risk management approaches are focused on protecting the tangible assets reported on a company's Balance Sheet and the related contractual rights and obligations. The emphasis of ERM, however, is on enhancing business strategy. The scope and application of ERM is much broader than protecting physical and financial assets. With an ERM approach, the scope of risk management is enterprise-wide and the application of risk management is targeted to enhancing as well as protecting the unique combination of tangible and intangible assets comprising the organization's business model.

## ERM Process: Developing a More Risk Aware Culture

Establishing a Risk culture has become a fundamental building block of good enterprise risk management (ERM) practices. Management's actions, as well as consistent, ongoing communication around ethics and risk management, are the first steps in instilling such a culture.

## Essence of ERM

For monitoring the performance of an organization with respect to corporate objectives, it is imperative to form control mechanisms that enable the identification of risks and which meet the predefined objectives. The COSO framework is based on 2004 publication on Enterprise Risk Management Integrated framework is a very standard and popular framework through which companies should be regulated and measured.

## COSO ERM Framework

The ERM framework by the Commission of Sponsoring Organizations of the Treadway Commission (COSO) provides a more disciplined and consistent standard against which to implement and assess a company's ERM program.

ERM provides a more holistic approach that enables the alignment of the organization's strategies and operational and compliance processes across the entire company for managing all the key business risks and opportunities with the goal of maximizing value for the entire enterprise.

ERM is a process-based approach where the various components interact as part of an on-going, iterative process. COSO represents these relationships in a three dimensional cube:

**Objectives** which are what the company wants to achieve whether strategic, operations, reporting and/or compliance.

**Internal Environment** components which represent what is needed to achieve the objectives. This is also called risk culture of an organization

**Entity Level** which represent the various units of the company.

Many have measured ERM's value in qualitative, "softer" terms — enhanced risk identification and prioritization, a common risk language, improved risk and controls optimization, better risk monitoring and reporting, and stronger risk governance and culture.

Similarly, estimating earnings variability can be feasibly undertaken both before and after ERM risk mitigation activities to demonstrate the impact and value of the ERM program. Applying a risk lens and

risk metrics to a business opportunity is also likely to result in improved investment decisions. ERM can assist in identifying areas of the business that would benefit from investment.

**Chart: Enterprise Risk Management Framework of COSO**

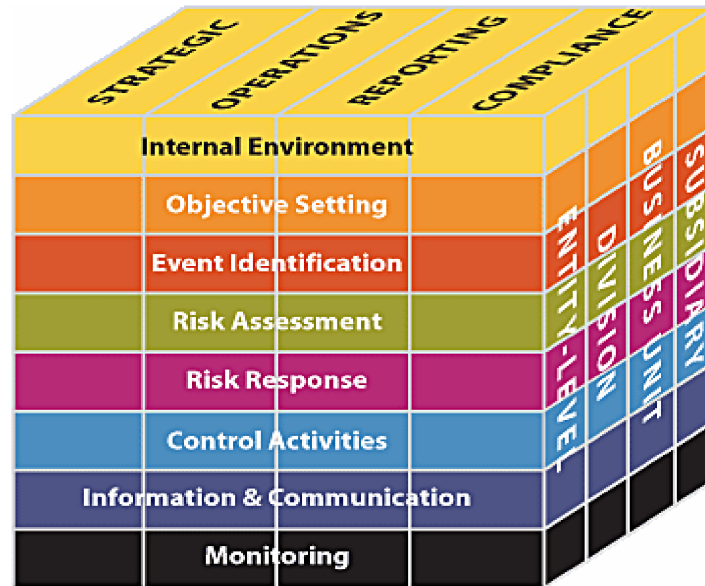

Risk Adjusted Return on Capital (RAROC) metric helps banks/FIs to make better decisions when approving, structuring, and pricing deals.

**8.2.7 Value at Risk**

Value at Risk (VaR) is one of the popular methods of measuring financial risks. There are different types of VaR—long-term VaR, marginal VaR, factor VaR, and shock VaR. VaR is also defined as the threshold value such that the probability of a portfolio making a market to a market loss over a specific time horizon exceeds this value. For example, if a portfolio stock has a one day 3 per cent VaR of ₹10 million, there is 0.03 probability that the portfolio may face a reduction in value by more than ₹10 million over a specific time period. This is on assuming that normal market operations and there is no trading. A loss which exceeds VaR threshold is known as 'VaR break'. VaR has applications in financial risk management, risk measurement, control and reporting. It can also be used in calculating regulatory capital.

VaR essentially identifies the boundary between normal days and extreme occurrences. The probability level is specified as 1 minus probability of a VaR Break. Normally VaR parameters are 1 per cent and 5 per cent probabilities and 1 day and 2 week horizons. While VaR represents loss, a negative VaR would indicate that a portfolio has a high probability for making profits.

There are two types of VaR—one is applied primarily in risk management and the other in risk measurement. For a manager who is managing financial risk, VaR is essentially a system and not just a number as it runs periodically and is compared with the movement of computed prices in opening positions over the particular time horizon. An interesting application of VaR is the governance of endowments, trusts and pension plans. VaR utilized for this purpose is to monitor risk.

VaR has the advantage of a structured methodology for critically analysing a risk that is available as part of management function. Daily publication of a number on time and with particular statistical data enables an organization to maintain a high objective standard. However, robust backup systems and assumptions regarding default need to be established. A quotation runs thus, 'risk taking institution that does not compute VaR might escape disaster but an institution that cannot compute VaR will not' according to Aaron Brown.



Another advantage of VaR is that it differentiates risks into two regimes, that is, normal days and extreme occurrences. Inside the VaR limit, application of the conventional statistical methods is reliable. Out VaR limit risk should be analyzed with stress testing on the basis of data available on the long-term and in the broad market. Distribution losses beyond VaR point are both impossible and useless. As such the finance manager should concentrate on developing plans to limit the loss if possible or to survive the loss.

VaR as a risk measurement is usually reported with other risk measurements such as standard deviation, expected shortfall, partial derivatives of portfolio value, etc.

Application of VaR is to segregate extreme occurrences in a systematic way. They can be studied over the long-term in a qualitative manner on the basis of day-to-day movement of prices, both quantitatively and qualitatively. As VaR can at best be utilized to define risk as a market to market loss on a fixed portfolio over a fixed time horizon in normal markets, it is not useful in abnormal situations.

There has been criticism against VaR. It is said that this concept has led to excessive risk taking and leveraging by financial institutions. Again VaR is not sub-additive which means that VaR of a combined portfolio can be larger than the sum of the VaRs of its components.

### **8.2.8 Evolution of Basel Regime:**

The Basel Committee on Banking Supervision, after an extensive consultation process, redrafted its recommendations for credit institutions' regulatory capital requirements (Basel I) issued in 1988. The revision was motivated by the wish to adequately reflect current developments in banking and to strengthen the stability of the international financial system. On November 15, 2005, the Basel Committee on Banking Supervision presented the revised version of the "Basel II" Capital Accord's framework agreement, initially released under the title "International Convergence of Capital Measurement and Capital Requirements" on June 26, 2004. The major difference between this document and the Basel I framework, which merely imposed minimum capital requirements on credit institutions, is that Basel II foresees also a supervisory reviewing process (Pillar 2) and broader disclosure obligations (Pillar 3).

#### **Basel-I**

As on date the provisions of Basel Accord of 1988 has undergone a number of changes made year after year. Though Basel II accord has become operational some of the covenants of Basel I (1988) are still relevant. Under the 1988 accord, Banks and security firms have been given different treatment. In the ensuing paragraphs we will focus on these developments.

#### **The Basel Accord (BASEL I)**

In 1988, the Basel Committee published a set of minimal capital requirements for banks. These became law in G-10 countries in 1992, with Japanese banks being permitted an extended transition period. The requirements have come to be known as the 1988 Basel Accord.

**What is a 'Bank' for the purpose of Basel accord:** To understand the scope of the 1988 accord, we need to clarify what we mean by 'bank.' This is because, some jurisdictions distinguished between banks and securities firms, and the Basel accord (Basel I) applied only to the former.

#### **Commercial Banks and Universal Banks - Glass Steagal Act, USA (1933-1999)**

Under its Glass-Steagal Act, the United States had quite some time back made a distinction between commercial banks and securities firms (investment banks or broker-dealers). Following World War II, Japan adopted a similar legal distinction. The United Kingdom also distinguished between banks and securities firms, although this was more a matter of custom than law. By comparison, Germany had a tradition of universal banking, which made no distinction between banks and securities firms. Under German law, securities firms were banks and a single regulatory authority oversaw banks. France and the Scandinavian countries had similar regimes. The USA revoked the Glass Steagal Act in 1999.



### **Exclusive Focus on Credit Risk During 1988-1998**

The 1988 Basel Accord -Basel I- primarily addressed banking in the sense of deposit taking and lending (commercial banking under US law), so its focus was credit risk. Under this dispensation, bank assets were assigned 'risk weights.' Generally, G-10 government debt was weighted 0 per cent, G-10 bank debt was weighted 20 per cent, and other debt was weighted 100 per cent. Following this the Government of India Securities were assigned zero risk weight. Having assigned and aggregated the risk, Banks were required to hold capital equal to 8 per cent of the risk weighted value of assets. Additional rules applied to contingent obligations, such as letters of credit or derivatives.

### **Market Risk - Recognition of the Need for Capital - Amendment of Basel I In 1996**

With banks increasingly taking market risks, in the early 1990s, the Basel Committee decided to update the 1988 accord to include bank capital requirements for market risk. This would have implications for non-bank securities firms. Any capital requirements the Basel Committee adopted for banks' market risk were to be incorporated into future updates of Europe's Capital Adequacy Directive (CAD) and thereby apply to Britain's non-bank securities firms. If the same framework were extended to non-bank securities firms outside Europe, then market risk capital requirements for banks, and, securities firms could be harmonized globally. In 1991, the Basel Committee entered discussions with the International Organization of Securities Commissions (IOSCO) to jointly develop such a framework. The two organizations formed a technical committee, and work commenced in January 1992.

### **Commercial Banks & Securities Firms - Universal Banks**

Glass Steagal Act revocation in 1999 by USA: Historically, capital requirements for banks and securities firms had served different purposes.

#### **Banks**

Banks were primarily exposed to credit risk. They often held illiquid portfolios of loans supported by deposits. Such loans could be liquidated rapidly only at 'fire sale' prices. This placed banks at risk of 'runs.' If depositors feared that a bank might fail, they would withdraw their deposits. Forced to liquidate its loan portfolio, the bank would succumb to staggering losses on those sales.

Though Deposit insurance and lender-of-last-resort provisions implemented eliminated the risk of bank runs, they introduced a new problem. Depositors no longer had an incentive to consider a bank's financial viability before depositing funds. Without such marketplace discipline, regulators were forced to intervene often at huge cost to the exchequer. One solution was to impose minimum capital requirements on banks. Because of the high cost of liquidating a bank, such requirements were generally based upon the value of a bank as a going concern.

#### **Securities Firms**

The primary objective behind stipulation of capital requirements for securities firms was to protect clients who might have funds or securities on deposit with a firm. Securities firms were primarily exposed to market risk. They held liquid portfolios of marketable securities supported by secured financing such as repos. A troubled firm's portfolio could be unwound quickly at market prices. For this reason, capital requirements were based upon the liquidation value of a firm.

### **Capital for Banks & Securities Firms**

In a nutshell, banks entailed systemic risk. It was thought then that Securities firms did not. Regulators would strive to keep a troubled bank afloat but would gladly unwind a troubled securities firm. Banks needed long-term capital in the form of equity or long-term subordinated debt. Securities firms could operate with more transient capital, including short-term subordinated debt.



## Segregation of Banking Book & Trading Book for Holding Capital

In April 1993, the Basel Committee released a package of proposed amendments to the 1988 accord. This included a document proposing minimum capital requirements for banks' market risk.

- *Banks would be required to identify a trading book and hold capital for market risk under trading book and organization-wide foreign exchange exposures.*
- *Capital charges for the trading book would be based upon a crude value-at-risk (VaR) measure broadly consistent with a 10-day 95 per cent VaR metric. Similar to a VaR measure used by Europe's CAD, this partially recognized hedging effects but ignored diversification effects.*
- *Later VaR measure was changed modestly from the 1993 proposal, still reflecting a 10-day 95 per cent VaR metric. Market risk capital requirements were set equal to the greater of either the previous day's VaR, or the average VaR over the previous six days, multiplied by 3.*

Banks to have independent risk management function and satisfy the regulator regarding its risk management practices

The Basel Committee's new proposal was adopted in 1996 as an amendment to the 1988 accord. It is known as the 1996 amendment. It went into effect in 1998.

The Basel Committee published a set of minimal capital requirements for banks and distinguished between banks and securities firms. Bank assets were assigned 'risk weights'. The primary purpose of capital requirements for securities firms was to protect clients who might have funds or securities on deposit with a firm.

### **Basel II:**

Broadly speaking, the objectives of Basel II are to encourage better and more systematic risk management practices, especially in the area of credit risk, and to provide improved measures of capital adequacy for the benefit of supervisors and the marketplace more generally.

The introduction of Basel II has incentivized many of the best practices banks, both internationally and in the Indian economy to adopt better risk management techniques and to reconsider the analyses that must be carried out to evaluate their performance relative to market expectations and relative to competitors.

Under Basel II regime, banks need to implement sound processes and systems to ensure that they are adequately capitalized at all times in view of all material risks. It has to ensure that Regulatory Capital requirements are more in line with Economic Capital requirements of banks and by this, make capital allocation of banks more risk sensitive.

*The Basel Committee replaced the 1988 accord (amended in 1996 and adopted in 1998) in April 2006. This has been dubbed Basel II. It includes more sophisticated treatment of credit risk. Basel II also addressed 'Operational risk', among other things.*

Chart: Basel II Structure

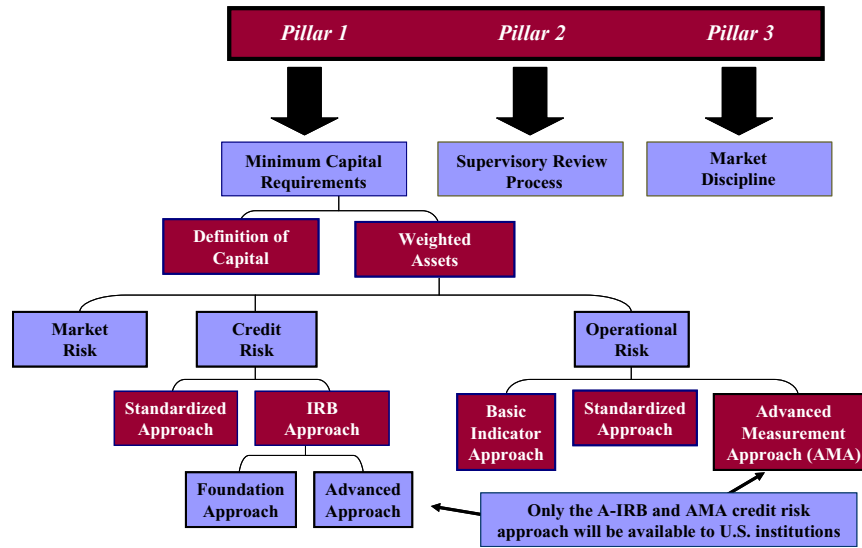

Under the new Basel II regulatory capital requirement, interest rate risk in the trading book continues to carry a minimum capital charge (Pillar 1 of Basel II). What is new is that interest rate risk in the banking book needs to be assessed in the review of capital adequacy (Pillar 2 of Basel II).

To calculate the minimum regulatory capital requirements, banks must differentiate between interest rate risks in the trading book (Pillar I capital) and interest rate risks in the banking book (pillar II capital).

Chart: Three-Pillar Architecture of Basel II

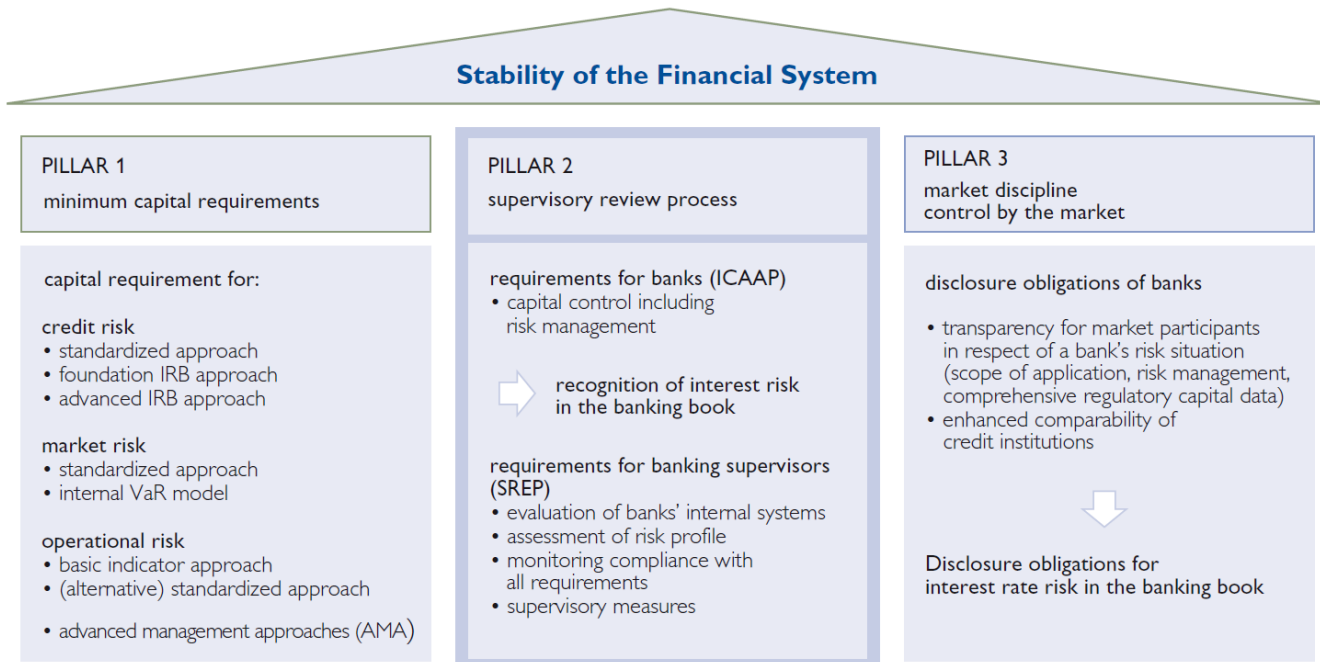

The above chart explains various approaches for calculating Pillar 1 and Pillar 2 risk capital under Basel II regime. For market risk, Banks have to report capital requirement for interest rate risk, equity position risk and foreign exchange risk (including Gold) to the regulator. Similarly, for credit risk, Banks in India currently follow the standardized approach and they report risk weighted assets for various credit exposures depending upon their external rating positions and hence compute capital requirement



for credit risk. Better the rating of the borrower (hence lower the risk), lower is the risk weights assigned by the regulator (here RBI). For example, where a AAA corporate rated by CRISIL will attract a risk weight of only 20%, a relative higher risky BBB corporate loan exposure will have to be weighed 100% to estimate risk weighted assets. Finally, all these risk weights need to be added and multiplied by 9% to estimate minimum capital requirement for taking credit risk.

Amount of loan  $\times$  Risk-weight  $\times$  9% = the capital required to be held against any given loan.

Similarly, for retail loans (e.g. residential housing loans, personal loans etc.) risk weights are different for different sizes of exposures depending on the availability of collateral margins (risk weights are less for higher margin, better collateral and smaller loan size).

Banks also use various credit conversion factors (CCFs) to convert their off balance sheet exposures (e.g. CCF=50% for credit guarantees; CCF=20% for cash credit etc.) into on balance sheet to estimate risk capital. Similarly, standard supervisory haircuts are used to take into account the benefit of eligible collaterals (like gold, bonds, NSC, KVP etc.) that reduces their credit risk exposures.

Under the Foundation Internal Rating Based Approach (FIRB), banks are allowed to develop their own empirical model to estimate the PD (Probability of Default) for individual clients or groups of clients. The other important risk parameters like EAD and LGD will be supplied by the regulator. Banks can use this approach only subject to approval from their local regulators.

Under Advanced IRB (AIRB) approach, banks are supposed to use their own quantitative models to estimate PD (Probability of Default), EAD (Exposure at Default), LGD (Loss Given Default) and other parameters required for calculating the RWA (Risk-Weighted Asset). Then total required capital is calculated as a fixed percentage of the estimated RWA.

For measuring market risk, Banks in India generally follows the standardized method that has been prescribed by the regulator. However, for advanced approaches, Banks can use internal VaR models coupled with stress testing exercises to estimate market risk capital charge.

For operational risk capital estimation, there are three approaches: Basic Indicator Approach (BIA), The Standardized Approach (TSA) and Advanced Measurement Approach (AMA). Under BIA, the capital charge is derived as a fixed multiple (alpha=15%) of three years average gross income of Banks. Under TSA, different business lines are assigned individual gross activity measures and the regulators determine the appropriate fixed multiple (beta) to calculate the regulatory capital requirement. The exposure indicator is gross income of various business lines of the Bank. The beta values range from 12% to 18%. Many Banks of India have already adopted BIA as well as TSA. Under the advanced measurement (AMA) banks have to use their internally defined risk parameters based on their historical internal loss data on Frauds, Business disruption & system failures, Execution, Delivery and Process, Transaction processing risk, Employment practices, Business Practices etc. Loss history represents the inherent operational risks and the state of the controls at a point in time. Loss data to be categorized according to an event-driven taxonomy that enables banks to have a risk profile for each event. Finally Banks can use Value at Risk (VaR) models to estimate figure for unexpected loss and operational risk capital subject to the regulatory review and approval. Some banks in India have applied for AMA. Involvement of Board of directors and senior management is a must for adopting AMA in a Bank.

As per existing Basel II rules, banks need to maintain minimum regulatory capital at 9% of the risk-weighted assets (internationally 8%). Out of this, not less than 50% should be Tier I capital. Capital Risk Weighted Assets Ratio (CRAR) =

*Eligible Tier I & Tier II Capital*  
*Risk Weighted Assets*

Major elements of Tier I Capital are retained earnings, paid-up equity capital, statutory reserves and other disclosed free reserves & some innovative capital instruments that are eligible for inclusion in Tier I Capital which also comply with the regulatory requirements (e.g. most junior claims, permanency,

quality issue etc.). Elements of Tier II capital are revaluation reserves, hybrid debt instruments, subordinated debt instruments and general provisions and loss reserves.

These prudential norms have been stipulated by RBI in India. For details, please refer to the Master Circular - Prudential Guidelines on Capital Adequacy and Market Discipline- New Capital Adequacy Framework (NCAF) of RBI issued in July 2, 2012.

The first component of Pillar 2 is the internal capital adequacy assessment process (ICAAP). Under ICAAP, credit institutions must have effective systems and processes in place to determine the amount, composition and distribution of internal capital on an ongoing basis and to hold capital commensurate with the required level. The second component of Pillar 2 is the Supervisory Review and Evaluation Process (SREP). The purpose of SREP is to evaluate banks' risk profile, to assess qualitative aspects (management, strategy, internal processes), and to impose supervisory measures if necessary. Under the Supervisory Review and Evaluation Process (SREP), the supervisors would conduct a detailed examination of the ICAAP of the banks, and if warranted, could prescribe a higher capital requirement, over and above the minimum capital envisaged in Pillar 1.

Pillar 3 is about market discipline as it mainly addresses the disclosure requirements by Banks to complement the minimum capital requirements (Pillar I) and the supervisory review process (Pillar II). The purpose of Pillar 3 is to ensure greater transparency in terms of banks' activities and risk strategies, as well as to enhance comparability across credit institutions-which are all in the interests of market participants. Pillar 3 recognizes the fact that apart from regulators, banks are also monitored by markets. It is based on the premise that markets would be quite responsive to disclosures - the banks would be duly rewarded or penalized, in tune with the nature of disclosures, by the market forces. Pillar 3 do not entail additional capital requirements but are limited to mandating the publication of key data, the disclosure of which neither weakens banks' competitive positions nor violates banking secrecy.

## COMPARISON BETWEEN BASEL I AND BASEL II

**Introduction:** In the previous paragraphs we have given the highlights of Basel I and Basel II. In this chapter we compare the two for better understanding.

*Comparison between Basel I and Basel II*

Basel - I (1988 and amended in 1996) – Based on Methodology for Capital Adequacy Basel - II (to be in place by 2006 in G-10)	Basel- II (to be in place by 2006 in G-10 countries and in India in 2008)- Basel II based on 3 pillars
1. Capital adequacy based on Risk Weighted Assets	1. Capital adequacy based on Risk Weighted Assets
2. Not risk sensitive. Prescriptive.	2. Risk sensitive.
3. All credit exposures carried risk weight of 100 per cent - except for some sovereign exposures and mortgages	3. Credit exposures carry risk weights based on credit qualities.
4. Risk Capital = Credit exposure * Risk Weights * 8 per cent can have lesser Capital than others	4. Risk capital: Similar to Basel I. But efficient Banks can have lesser capital than others

Implications were	Implications are
<ul style="list-style-type: none"> <li>• Every bank had to maintain same 8 per cent capital. Thus Banks with good quality assets had no incentives. As a result credit quality had to be lowered to increase returns</li> <li>• Low rated exposures were subsidized by high rated exposures</li> <li>• No provision for economic pricing by banks</li> </ul>	<ul style="list-style-type: none"> <li>• Banks with good quality assets have incentives because they can manage with lower capital</li> <li>• Better quality assets requires lesser capital</li> <li>• Risk pricing can be done by banks based on credit risk perception</li> <li>• Provision exists for economic pricing by banks</li> </ul>

### Basel III:

Reserve Bank of India in May 02, 2012 has released its final guidelines on implementation of Basel III capital regulation in India. These guidelines would become effective from January 1, 2013 in a phased manner. The Basel III capital ratios will be fully implemented as on March 31, 2018. This entails higher global minimum capital standards for banks. Implementation of Basel III is essential for restoring confidence in the regulatory framework for banks and to ensure safe and stable global banking system.

The Basel III framework sets out the following:

- Higher and better equity capital
- Better risk coverage
- Introduction of a leverage ratio
- Measures to promote the build-up of capital for periods of stress
- Introduction of new liquidity standards

A key element of new definition is the greater focus on “common equity” (paid up equity capital, reserves, retained earnings etc.). In addition to raising the quality of the capital base, banks need to ensure that all material risks are captured in the capital framework. What counts as core capital may impact the Indian banking sector's competitiveness significantly.

As per the RBI's new Basel III capital regulation, common equity (or core Tier I) should be at least 5.5% (1% higher than the original Basel III rule) & minimum Tier I capital should be at least 7% of total risk weighted assets. There should be predominance of common equity and Tier I regulatory capital. Common equity 78.57% of Tier I capital & total Tier I capital should be at least 77.58% of total minimum capital (as per RBI's Basel III circular).

Basel III regulation expects that Banks for its survival in future must understand the importance of people perception about a Bank's liquidity condition (short term as well as long term) besides internal management of liquidity. It emphasized that banks' liquid assets should be sufficient enough to cover net cash outflow. Two liquidity standards/ratios are proposed:

- (i) **Liquidity coverage ratio (LCR)** which is the ratio of Liquid assets to net cash outflow for short term (30 days) liquidity management and
- (ii) **Net stable funding ratio (NSFR)** for long term structural liquidity mismatches.

The regulator expects that LCR should be more than 100 percent and it will act as an indicator of short term (30 days) resilience of a bank under a stress situation. LCR will require banks to have sufficient high-quality liquid assets to withstand a stressed funding requirement. As a long term liquidity measure, bank should ensure that their Net Stable Funding Ratio (i.e. the ratio of available stable fund to required stable fund is >100%. The NSFR aims to limit over reliance on wholesale funding during times of buoyant market liquidity and encourages better assessment of liquidity risk across all on and off balance sheet items.

Basel III also wants to ensure that banks' leverage ratio (Tier I capital divided by all on & off balance sheet items) should be at least greater than 3%. Unlike debt equity ratio, it is just the reverse ratio that indicates bank solvency. It must be calculated as an average over the quarter. Minimum leverage ratio should be at least 3% during parallel run (January 1, 2013-January 1, 2017). Bank level disclosure of leverage ratio is proposed to start from January 1, 2015.

Basel III urges banks to maintain high credit ratings to ensure greater solvency and to avoid costs of raising additional capital under unavoidable market conditions. It expects that bank should create buffer in good time so that it can be used in bad time. The regulator may take Credit to GDP ratio as a measure of balancing factor and calibrating measure.

### **8.2.9 Different Corporate Risk & their Management**

In today's business environment, there are several ways an organization can help to ensure they are setting the right tone and imbedding processes into their day to day operations to help manage corporate risks. We will now discuss the various corporate risks an organization faces and how they can be managed so that the uncertainties can be reduced.

#### **8.2.9.1 Types of Corporate Risk**

The array of risks that have risen due to the winds of change, that is, the globalization of markets and liberalization of economies, all over the world. These risks have affected corporate strategy in different forms and can be identified specifically as corporate risk. Most of these risks emanate from the industry in which the company is operating, competition or else are directly related to intangible assets or the business of the company. They are discussed as below:

##### **Industry Risk**

This risk arises when the industry itself faces extinction suddenly, due to unavoidable reasons. Industries have known to have a life cycle that is comprised of 4 stages: startup, growth, maturity and decline. However, some industries have faced a fractured life and sudden death. For instance, industries that produced valve radios for many decades failed suddenly when transistors (miniature valves) came on the commercial scene.

Michael Porter's five forces theory has addressed the industrial arena and posits a differing emphasis of the forces depending upon the nature and competitive level of business. Bargaining power with the vendors was balanced as long as the relationship was between two indigenous corporations. However, with the changed world and economy, negotiations between vendor and vendee across borders need more tact and understanding. In the same manner, the bargaining power and aspirations of the customer have increased enormously in tandem with the array of products that are offered in the marketplace.

Mass customization has become a reality and industry has to face up to the situation. Threats caused by internal rivalry among existing companies have also added to the complexity of an industry. These risks have led to the premature failure of several industries in different countries that have not been able to meet the stringent requirements of competition.

##### **Some of the risks faced by Sterlite Industries are discussed below:**

The Madras High Court on 28 September 2010 ordered the closure of Vedanta group company Sterlite Industries' copper smelting plant at Tuticorin after noting that the company had failed to comply with environmental regulations.

A divisional bench comprising justices Elipe Dharmaro and N. Paul Vasanthakumar held that the plant was within 25 km of an ecologically-fragile area and that it had failed to develop a green belt of 250 meters around itself.

The court also directed the Tuticorin District Collector to take necessary steps for re-employment of the



workforce in some other companies so as to protect their livelihood. This would occur, to the extent possible, keeping in view their educational and technical qualifications and experience.

It was also noted by the judges that there had been unabated pollution by the respondent company, which should be stopped so as to protect nature from being 'tarred'.

The plant was set up amid protests and widespread agitations from people of different sections in Tuticorin. The Tamil Nadu Pollution Control Board (TNPCB) had issued permission to Sterlite to run a unit to manufacture 391 MT of blister copper and 1,060 tones of sulphuric acid.

The 'no objection' certificate was issued by TNPCB to the company on the condition that it developed a green belt of 250 metres width around the 'battery limits' of the industry.

### **Transition Risk**

Risk usually arises when technological obsolescence suddenly overtakes the company. This risk can be traced partly to the complacencies developed by the firms in certain industries under a protected economy when a favourable import duty structure is levied by the Government so that the indigenous industry is able to thrive. However, these approaches have led to a state where these protected companies, become secure due to their continuing profitability and do not recognize the obsolescence of their technology as they are insulated from the onslaught of new technology.

Many industrial estates in India that thrived during the middle of the 20th century came to grief towards the end of the century when globalization and liberalization gained pace hand in hand. This was because the state-of-the-art technology that was espoused by advanced nations helped place their products with better quality at lower prices. This phenomenon has also happened in the IT field when new products were introduced very frequently based on new technology. The life of a technology which had been normally a decade or more, today suddenly finds itself reduced to a period of less than five years. This unexpected change of events in the history of IT has posed a transition risk for many industries. Technology has made many factors of productions namely men, machinery, and capital suddenly redundant.

As the time frame required for a turnaround or transition from one technology to another differs, companies face transition risk, according to their preparedness and their position in the life cycle. In addition, consumer behaviour has become an enigma clue to the wide variation and aspiration of different customers. This wide variety in the requirements of customers is also one of the factors leading to the extinction of technology that is no longer relevant to the customer, such as the case of black and white televisions.

### **Stagnation Risk**

This risk is associated with the stagnation of a company caused by a sudden fall in demand due to a recession. This risk has to be faced by almost all industries in the country. The unexpected nature of such a risk has left many companies high and dry as shown by the 2008 financial meltdown. When a company is exposed to such a risk, even fixed/committed costs cannot be recovered as the level of operations is usually far below the breakeven point.

Stagnation risk, due to its suddenness, has also left many companies with high inventory holdings of raw materials and components. Some companies have even had high product inventories due to earlier commitments that were subsequently not met because of recession. The unevenness of the stagnation risk is another feature and compounds the risk of an inability to meet commitments to vendors and labour.

The impact of this risk is heightened as the time frame of a recession is not finite especially if it aggravates into a depression, compounding into a chain reaction that will necessitate layoffs, temporary suspension of production etc. For example, when an automobile company is affected by stagnation, all the components manufacturers that are supplying the products to the company also suffer because the derived demand unexpectedly comes under pressure. These components manufacturers essentially



are small-medium enterprises and do not have the resilience or the staying power required to fight out a recession.

### **Unique Competitor Risk**

This risk arises when a unique competitor enters the scene unexpectedly. Competition, even if intense, can be managed as long as the two opposing parties are equal. Each company has its portion of the pie and the market share of each company grows with the growth of the industry at the macro level. In this scenario, if a large company unexpectedly enters the market and creates an imbalance, it leads to unique competitor risk. This risk is a culmination of the big resources, high technology, and managerial skill that the unique competitor (new entrant) possesses.

This risk has happened whenever protected industry faces an open market. This phenomenon is equally applicable to manufacturing, trading, and service industries. When large players such as Du Pont, and Chevron entered the high-tech chemical industry in India, smaller companies that already existed in this industry had to completely restructure themselves to stay in business.

In the same manner, in retail trade, after the entry of big competitors such as the Reliance and Birla groups small-time shopkeepers, street vendors, and other unorganized sector participants have all had to face big survival-related risks. For example, in the service sector, due to the entry of international consulting powerhouses such as Morgan Stanley, KPMG, and Deloitte, there has been a tremendous impact on small firms, individual consultants, and individual auditors. More than the strength of the unique competitor, the unexpectedness of their entry causes a big risk and this risk needs to be managed very intelligently. As can be seen from the examples, the unexpected entry of the unique competitor actually creates business risks relating to the survival of the smaller group of entrepreneurs.

### **Brand Risk**

This risk is again a very serious one because any company can grow and build its market share on the basis of its brand equity and brand loyalty. By the sheer weight of brand equity, many companies have been able to build market share even in diversified products that are unrelated to the original branded products. For instance, the brand Parry's in South India was well-known in the region as promoters and marketers of agency products. Parry's actually promoted Horlicks and Britannia in the food product segment, Kirloskar in the engineering segment, and confectionaries under its own brand name. Such is the power of a good brand and if such a brand were to lose its sheen suddenly; brand risk emerges and the company may face virtual extinction. This unexpected happening can take place due to the loss of confidence from the customer on the value of the brand.

Such occurrences have taken place in the automobile industry when due to a design problem, commercial vehicles and passenger cars have been recalled. Such unexpected events, lead to serious losses of brand image. These companies take some time before returning to a normal state. In the same manner, in the cosmetic industry, customers purchase products purely on the basis of brand loyalty. A product that has not been fully-tested may turn out to be allergy-causing to some customers because of which the company may face litigations. More than the litigation itself, the company faces a brand risk and is not able to market its other products for a substantial period of time.

Vicco, the Ayurvedic skin cream and toothpowder brand, finds the going tough even as the market for herbal-based products is growing at a blistering pace. The herbal bandwagon is on a roll. Green is in and marketers are happily counting in the greenbacks. The sudden rise of the herbal segment is because of health-consciousness. Even as the herbal wave gets new players, some of the older players seem to be struggling in the deep sea.

One of the brands struggling to stay afloat is Vicco (shorthand for Vishnu Industrial Chemical Company, a family enterprise currently controlled by the second generation). After pioneering the ayurvedic and herbal-based products category, it launched Vicco Vajradanti toothpowder in 1952 and subsequently Vicco Turmeric cream in 1975.

According to an AC Nielsen retail audit (in January-June 2002), Vicco is barely inching ahead in the herbal and natural skin cream segment with a mere 1.7 per cent value growth in 2002, while relatively newer brands such as Ayur have showed a 29 per cent growth in the same period. In fact, according to A C Nielsen, Vicco is ranked second, leading in terms of value, but that is because its prices are much higher than that of other herbal products. However, in terms of volume, it does not figure in the top five brands and has shown little percentage growth. Vicco's case highlights another example of how successful Indian brands in the protection era have lost out in the face of aggressive competition. Strategists take a look at what ails the Vicco brand. When Vicco Turmeric was introduced in 1970 as a pure and natural product in bottles, it was pitched against vanishing creams such as Afghan Snow and Hazeline Snow from Burrough's Welcome. Priced at ₹2 for a 60gm bottle—more than 50 per cent higher than other brands, mainly owing to the high prices of sandalwood oil, the base ingredient—the brand set out to make its mark.

However, the yellow-coloured contents failed to impress consumers, who were used to whitish creams. Even after attempts at direct selling, the brand struggled for five years. Meanwhile, the company hit on a packaging idea, taking a cue from the epoxy-coated aluminium tubes used to package its toothpastes in 1967. In 1975, Vicco Turmeric was relaunched in tubes. However, consumers were still vary — only medicinal ointments were packed in tubes then. So the company decided to turn a disadvantage into an advantage by consciously choosing to harp on the therapeutic benefits. However, what went against the brand was the fact that it was launched around a time when most Indian consumers were shying away from traditional home remedies or towards cosmetic offerings. Says Pendharkar, 'The main challenge was to revive and reinforce the natural and traditional efficacy of the contents in the products.'

In addition, as Mishra points out, Vicco failed to recognize the fact that the homely 'banno' (girl in Hindi) had now metamorphosed into a modern and confident woman. Marketers such as Cavinkare and HLL too had modified their communication accordingly to target the contemporary woman.

In addition, in the oral hygiene market, marketers started targeting the right target audience. For example, Pepsodent successfully targeted mothers and kids while Colgate's communication for Colgate Total focused on working executives.

As Fair & Lovely's market creation efforts bore fruit for fairness creams, the other competitors confronted Vicco directly in the ayurvedic cream segment. Emami's Naturally Fair cream, launched in 1986 was one among the many in the market. The 'safe' herbal formulation clicked and today Emami is the market leader in the herbal, ayurvedic, natural (HAN) segment according to AC Nielsen. In the oral hygiene market too, it was more or less a similar tale.

Dabur's Lal Dant Manjan toothpowder and Balsara's Promise toothpowder were rising to be formidable players, especially in rural markets. In addition, Balsara's Babool, launched in 1988, which was not intentionally launched as a herbal toothpaste, managed to gather a 4 per cent volume share by 2000. The new brands on the block were promising the same benefits as Vicco, but at a lower price. In a competitive market, consumers did not find a strong enough reason to pay for Vicco. There was little that Vicco could do about the price in certain segments. In the case of Vicco Turmeric, the price of the important ingredient, sandalwood oil, had shot up from ₹350 a kg in the 1970s to as much as ₹15,000 per kg by the late 1990s. A 100 gram tube of Vicco toothpaste costs ₹48.30. In comparison, a pack of Colgate Herbal (launched by Colgate Palmolive in 1999), is priced at ₹23 for a similar tube. In addition, while a 30gram tube of Vicco Turmeric is priced at ₹61.90, a similar tube of competitor Fair & Lovely retails at ₹26.

To be fair, though the benefits offered by Vicco products could have been different, the product experience was not communicated effectively to the consumer. Agrees Nikhil Vora, FMCG analyst, Alchemy: 'The company is obviously not spending enough on marketing efforts to justify the higher price.'

Compare this to Colgate Herbal, where the company spent a good deal on advertising the launch. It also communicated some of the specific ingredients such as neem, tuisi, clove, and mint, while Vicco just harped vaguely about '20 herbs' as its ingredient mix for years.

Instead, Vicco took its eye off the local market and chose to concentrate on its exports business that currently contributes to over 15 per cent of its turnover.

For the global market, the company manufactures a larger product range comprising herbal face washes, sun tan creams, shaving creams, all-purpose creams and so on, that are sold in supermarkets and 'natural health stores' by distributors abroad. This focus on foreign markets has had more than its share of risks. In the 1990s, when Vicco's communication was drowned by the noise made by a deluge of competition in both skin creams and oral hygiene, the company's attention was diverted in setting up a manufacturing plant in Yugoslavia, to cater to the business opportunity in Russia. Unfortunately, the gambit failed due to the disintegration of the Soviet Union.

While Vicco was in time to ride the herbal wave in international markets, it failed to do the same in the domestic market. A lot has changed since the early nineties, when herbal products were considered a downmarket product offered by regional players.

At a time when the world was changing dramatically, Vicco blissfully closed its eyes and chose to stick to its traditional themes. In the early half of the last decade, even as the total herbal market grew to ₹25 billion at a growth rate of 40 per cent, Vicco was reduced to being a negligible player (although Vicco claims a turnover of ₹1 billion) in a category that it once played a role in creating. It now seems to be the right time to work on its faded charm. However, will Vicco manage to do it?

### **Project Risk**

We have already discussed about the project risk, now we will explain this with some example which are as follows:

Tanneries in and around Vaniyambadi and Aambur in Tamil Nadu have had to face closure as the pollutants they created affected the water table in those areas and made the ground water unfit for potable purposes.

The Vedanta Group of industries that is at present engaged in an aluminium project in Orissa, is facing a big project risk due to alleged environmental violations that are affecting tribal settlements. Original assumptions relating to the resettlement and rehabilitation of the tribals were not been properly tested, clarified, or settled. Besides, another form of project risk has arisen due to an unexpected shift in government policy that had not been foreseen in the assumptions.

In the 1990s, the Government of India devalued the Indian rupee and many projects that had taken the lower parity between Indian rupee and American dollar as a base assumption faced big project risk. This resulted in the loss of viability of the projects and many failed to take off. In certain other cases, project risks emerged due to the assumptions relating to the demand for the product to be manufactured, without actually assessing the stage of the life cycle of the product. When a product is in a decline stage, it is erroneous to assume that the demand for the product will grow, especially when there is a gestation period for the project extending to a number of years. In such cases, project risk surfaces and affects the viability of the project.

In service industries such as banking, insurance, IT, and hotel management, project risks have been known to occur due to drastic changes in assumptions for a particular project. Recently, when the Commonwealth games were held in New Delhi, the hotel industry had assumed that a large number of foreign tourists would come to India during these games. However, only a fraction of foreign tourists actually visited India. In the banking industry, many banks had to face large percentage of non-performing assets due to deviations in the base assumptions under the instruction for priority lending. Similarly, in the insurance sector, assumptions relating to fire risks have had to be revised drastically as the experience all over the world relating to fire insurance did not hold well with them. In the IT sector also, many companies embarked on big projects and on the basis of their assumptions recruited



hundreds of IT employees. However, due to drastic changes in the world economy, a sizeable number of these plans had to be put on hold and many could not be sent letters of appointment.

In 2010, the environment ministry stepped in to keep Vedanta—a company promoted by Anil Agarwal—from developing its plans to mine in Orissa's Niyamgiri Hills. Buried deep within are huge reserves of bauxite. The tribals in the Dongria and Kutia Kondh have been officially recognized as primitive tribal groups that need special protection. The hills are their only habitat.

Vedanta is already in substantial business in this part of Orissa's Kalahandi district. It operates a 50 billion alumina refinery plant set up in 2006 in Lanjigarh, at the base of the Niyamgiri Hills to process alumina from bauxite ore. Currently, the bauxite is bought from 14 different mines in Chhattisgarh, Jharkhand, and Gujarat. At this location, the transportation costs are formidable. Hence, Vedanta wants to mine the bauxite that is just three kilometres from its refinery.

The Union Government says it has evidence that at the refinery in Lanjigarh, Vedanta has exploited the bauxite-rich area in violation of environmental laws and tribals' forest rights. Environment Minister Jairam Ramesh said, 'There has been a very serious violation of the Environment Protection Act, Forest Conservation Act, and the Forest Rights Act. There have been no emotions and no politics and no prejudice involved in this report.' The Government's position is shaped heavily by the report of a committee set up by the Ministry of Environment and Forests to study whether Vedanta had complied with environmental laws and had therefore passed the test that would give it a 'Stage 2' or final clearance from the Government.

### **Operational Risk**

According to the Basel Committee, 'Operational risk is the risk of loss resulting from inadequate or failed internal processes, people and systems or from external events' Operational risk arises from execution of the normal operations of the company involving people, systems, and processes. It is different from other risks as it is not used to generate profit/returns and the relationship of risk and return does not exist in the case of operational risk.

As operational risk is inherent in a company, the management is aware of the type of operational risk. Basel II has defined operational risk as follows:

- (1) Internal fraud—misappropriation of assets, tax evasion, intentional mis-marking of positions, and bribery
- (2) External fraud—theft of information, hacking damage, third-party theft, and forgery
- (3) Employment practices and workplace safety—discrimination, workers compensation, employee health, and safety
- (4) Clients, products, and business practice—market manipulation, antitrust, improper trade, product defects, fiduciary breaches, and account churning
- (5) Damage to physical assets—natural disasters, terrorism, and vandalism
- (6) Business disruption and systems failures—utility disruptions, software failures, and hardware failures
- (7) Execution, delivery, and process management—data entry errors, accounting errors, failed mandatory reporting, and negligent loss of client assets

It may be useful here to note the reasons for the non-performing assets (NPAs) in the state of Jharkhand, as explained below.

A study of NPAs in Jharkhand focused on three groups of people: bankers, borrowers, and others (includes chartered accountants/lawyers and academicians). It was observed that there are quite contradictory views among the responders over the reasons for NPAs under discussion. In all the districts except those of Hazaribagh and Gumla, bankers feel that 'lack of entrepreneurship' is the most important reason for the generation of NPAs. This response is more prominent in Bokaro district.

However, bankers in the districts of Hazaribagh and Gumla hold 'wilful defaults' as one of the important reasons.

It is worthwhile to mention here that when bankers there were asked what factors they looked into for terming a borrower as a willful defaulter, there was unanimity in their responses though a majority of them considered the fact that despite their good financial health, a borrower still defaults or delays the payment of loan installments. The borrowers hold 'market failure' as the reason for the inability to service loans in time. It is, however, interesting to note that neither bankers nor others consider that poor follow-ups and supervision lead to higher level of NPAs. This is against most theories suggested on this subject where poor credit appraisal or follow-ups lead to generation of NPAs in banks.

### **8.2.9.2 Relating Corporate Risk to Management Principles**

It is important to understand each of the corporate risks and use an appropriate approach to manage the same. Though in principle, all efforts must be taken to reduce risk to a certainty, it is difficult in reality. Different approaches towards risk management may lead to variant levels of risk management and a wrong approach may lead to failure. Hence an appropriate approach must be identified and deployed for managing risk.

#### **Industry Risk**

Approaches to mitigate industry risk can be twofold. An industry is usually at risk when a new substitute is available on the market. The industry can mitigate this by creating new versions of its products through research and development. This can help forestall the substitute.

A German proverb says 'an industry should substitute its own product before a competitor substitutes the same'. This is a preventive strategy to avoid industry risk. In the same manner, extinction due to consumer preferences can be tackled by a proper continued dialogue with the customer. This can be done through market feedback on a regular basis, so that the pulse of the customer is fully understood and the industry can expect the unexpected. Non-availability of raw materials or components from the vendors can also throw the industry into risk.

For example, Sindri Fertilizers and Chemicals came up as a synthetic chemical fertilizer plant in Bihar in the 1950s using coal from Bihar mines and gypsum from Pakistan for its manufacturing. However, after the partition in 1947, the availability of gypsum from Pakistan posed an industry risk and the fertilizer company had to identify new gypsum sources in Rajasthan. Using Rajasthani gypsum led to a modification in their manufacturing process. This industry risk was successfully neutralized.

Another approach to tackle industry risk can be through industry associations. Major industries such as sugar, textiles, chemical, and cement, have their own associations that cater to the common needs of the industry. These associations are tuned not only to analyse the performance of group members but also to identify industry risks and evolve suitable approaches to meet them. In addition, these associations have developed business intelligence sources that keep the industry fully prepared to meet any eventuality. These specific approaches are based on the traditional principles of risk management, namely avoidance and mitigation.

#### **Transition Risk**

Sudden technological obsolescence or premature technological obsolescence leads to transition risk. One approach to manage this in certain industry circles is through technology forecasting. Like a product, a technology also has a life cycle. As such, continuous monitoring of technology is an essential guide in the assessment of technological obsolescence as well.

The other approach has been for a company is to be proactive and change its technology before the present one becomes obsolescent. This approach has not only avoided transition risk but also provided strength to the company. For, the company could preempt its competitors by going in for state-of-the-art technology before it is unexpectedly overtaken by obsolescence.



In the InfoTech sector in the past, many companies used a single main frame installation. With the onset of personal computers, the whole scene changed and the big mainframe computer model vanished. However, the IT industry managed to adapt to this change by restructuring companies and retraining people to use the new technology.

Similarly, in the telecom industry, the new wireless technology for mobile phones challenged the old fixed-line models, but the transition has been managed well by combining landlines with new broadband technology and promoting the benefits of the existing landline cable technology. Also, the landline communication industry itself has taken on wireless communication as a diversification and thus has reduced transitional risk. Thus, the principle to meet transition risk is both mitigation and retention of risk, as can be seen in the following:

The Northrop Grumman team recognizes the importance of planning and executing a successful transition of the Virginia Information Technologies Agency (VITA), its current operational services, and subsequent transformation of the IT environment. This establishes a high level of confidence with VITA, with particular emphasis on a smooth transition of VITA staff to Northrop Grumman.

Through a subsequent phased methodology of stabilization, optimization, and transformation, Northrop Grumman establishes a solid baseline to effect change and revolutionize the current service delivery model by establishing new standards, automating functions, consolidating hardware, refreshing the environment, and centralizing services.

One of the key factors to a successful transition is the risk management process. Northrop Grumman uses a formal risk methodology that identifies risk, assesses probability of occurrence, and develops a risk mitigation plan. Through preparation, Northrop Grumman can reasonably anticipate the problem areas and can call on approaches to mitigate or minimize those problems for transparent transfer of operations.

The following table lists examples of risks and mitigation actions that Northrop Grumman would anticipate during the early phases of transition.

The Northrop Grumman team understands the critical importance of risk mitigation and elimination during start-up and transition.

TABLE: Risk mitigation table

<b>Risk Description</b>	<b>Mitigation Approaches</b>
Transition to new contract and contractor may result in loss of key skills and knowledge	Transfer key knowledgeable VITA staff to the Northrop Grumman team and motivate VITA staff to join Northrop Grumman team, obtain debriefs from departing key staff, and leverage VITA-managed employees.
Delay of any new support tool installation or implementation may affect the ability to meet Service Level Agreements (SLAs)	Work closely with VITA to develop prioritization of support tool installation and implementation so that key service levels are met quickly and so agreement can be reached regarding timing for activation of added service levels.
Customers do not adopt new capabilities, build workaround solutions, and operate outside VITA service environment with ghost IT staff	Communicate benefits of change to organization, customer groups, and employees; develop super user community of 'ghost' IT staff with real roles; create structure to detect and say 'no' to misaligned activities.

Blended management and delivery model because not all VITA personnel will transfer to partner due to Workforce Transition Act	Retain most VITA staff through career opportunity, equivalent benefits, retention bonus, and effective communication plan; develop roles and responsibilities and rules of engagement; implement annual performance bonus program.
Asset management process lacks the details required for a well-defined and managed services solution including maintenance.	Perform site surveys from a design perspective in understanding the capabilities of the LAN and WAN equipment, in addition to the normal 'where is, as is' site survey; this information will be provided to our refresh program to update the necessary equipment to support managed services.

### Stagnation Risk

This risk has been combated in a number of ways as stagnation affects not only the company but also the macro economy. Concerted efforts have been made both by companies and the government of the countries. While the company braces itself to restructure its operations using different strategic turnaround models, or business process reengineering, and business process management, the Government also adopts both fiscal and monetary packages to stimulate the economy. Fiscal measures include lowering of taxes, duties, and levies. The qualitative monetary measures relate to the provision of subsidy drawbacks, built into a time frame to stimulate demand. This approach stems from the fact that the risk is accepted and the measures are implemented to mitigate the risk.

### Unique Competitor Risk

The unorganized sector has been the main sufferer from this type of risk in the retail sector. In a similar manner, small and medium enterprises have also been affected by big players entering the scene. Unique competitor risk can be mitigated by ingenious and innovative ideas of developing self-help groups, organizing the unorganized sector, and by providing micro finance to small entrepreneurs.

The Bangladesh experiment of Grameen Bank has been a success story and this experiment is being replicated to empower the unorganized sector. Small and medium enterprises are also being helped by the Government under special schemes by the banking industry, by providing them with adequate credits such as export credits in the case of Tirupur hosiery industry.

In a market-operated world economy affecting both developed and developing countries, the entry of unique competitors cannot be prevented. For example, such competitors may source products from indigenous sources including small and unorganized sectors and meet with significant success. The farmers who cultivate vegetables are encouraged to market directly to the consumer or to the competitor so that they are assured of substantial off takes at reasonable prices. Support prices from the Government for agriculture commodities such as paddy, wheat, sugarcane, and cotton has also helped mitigate the effect of the entry of a competitor. This approach again follows the principles of risk retention and mitigation.

### Brand Risk

This risk has been occasioned more due to a hasty decision-making style and non-fulfillment of certain procedures. Certain companies have introduced expert committees consisting of cross-functional members whose expertise is unrelated to the branded products. This committee plays the devil's advocate before a new product under an existing brand is launched. The committee's deliberations include consumer preferences as well as the legal requirements and specifications of the product. These deliberations also take into consideration test markets and quality function deployment (QFD) procedures. Thus, brand risk can be mitigated to a large extent by such policies and procedures.

In some occasions when big companies have faced brand risk they have issued a massive recall of the products and to mitigate the brand risk. This helps to a large extent in protecting the image of the company's ethics among consumers.

### Project Risk



Projects in themselves are unique and have a fixed timeframe with fixed start and end points. Every project varies from another one but all projects are subject to the similar kinds of risks. Such risks arise mainly due to the heterogeneous mix of the project team, which is represented by companies' representatives, contractors, and third parties who enter the project either at the behest of the company and the contractor, or at that of stakeholders such as collaborators, vendors, and logistics people. This heterogeneous mix needs to be brought into a matrix and made to work in a coordinated fashion. However, various stakeholders do not have managerial powers except for contractual obligations and hence many risk factors are identified in a project only in the following fashion:

**Lack of project team skills** - Often some local labourers who have no previous exposure to the type of work culture required of the project, are employed, usually due to budget constraints, contractors tend to pay workmen at rates that may not attract the best of skills. However, this prime risk factor may compound into indifferent performance in the quality of project work. Proper leadership monitoring and coordination, and on the job training can mitigate this risk significantly.

**Ineffective communication systems** - Organizationally, there are a few parallel setups in a project site that lead to authorities and decision makers functioning as islands. In project work, the most important factor is alignment of activities and maintaining the line of balance (LOB). An ineffective communication system leads to misalignment, in which case the LOB is lost.

To effectively mitigate this risk, project coordination meetings are held between the company's management and other stakeholders of the project on a daily or weekly basis. This is carried out to enable effective communication among all the stakeholders. A project framework, using techniques such as critical path method (CPM) or program evaluation review technique (PERT) also needs to be developed with the consensus of all stakeholders. A line of balance is established through an alignment of the various activities.

**Inadequate supplier stability and performance** - While a few of the stakeholders who are physically present at the project site can be effectively communicated to on a day to day basis, there are stakeholders such as vendors, transporters, consultant companies and headquarters administration, who are away from the site. Project activities on the site are based on certain assumptions such as arrival of equipment and machinery on particular dates, availability of financial resources from the headquarters on a planned basis to meet the project site expenditure, and third party inspections for quality assurance at the vendor premises. Poor communication with the stakeholders who are away from the project site can lead to serious project risks, resulting in time and cost overruns.

To effectively reduce these risks, the stakeholders should also be a party to project plan activities and should be made aware of the repercussions that would follow when deadlines are not met. This particular aspect is often taken care of by having a project control cell at the company's headquarters. These cells have hotline communications with the companies' representatives as well as with vendors, transporters, and consultants. The project control cell at the headquarters thus becomes a hub for controlling and reducing the project risk of time and cost overruns.

**Ineffective consultants** - Engineering consultants play a vital part in any project. They are responsible for providing detailed engineering designs and drawings apart from selecting, negotiating, and following up with vendors for the supply of plant and machinery. The experience of consultants in a particular type of project is essential and many times, this area becomes nebulous as the contribution of the consultant becomes ineffective. This results in quite a few site modifications and compromises. This project risk can normally be mitigated by selecting a consultant appropriate to the project. Laying down ground rules for effective communication between the consultant's representatives at the design office and their representatives at the site should also be encouraged. Consultants should also be made responsible for monitoring supplies so that the deadlines are met.

**Ineffective strategic plans** - A project is unique and involves a fairly long timeframe consisting of the genesis of the project, collaboration agreement, detailed project report, developing a procurement plan for plant and machinery, civil works, mechanical erection, electrical and power, instrumentation



and control, and commission of the completed plants into commercial production. The strategy formulated and implemented on a project is complex due to the diverse elements and hence poses project risk, if it is inadequate or ineffective. To avoid this risk, the strategy must be more a functional strategy with an exposure to business strategy. For example, production technology could be an aspect of production strategy and must be in synchronization with overall business strategy with regard to capital and labour relevant to the host country. This becomes much more relevant in case of cross-border transactions in the form of imported technology, and imported plant and machinery.

Apart from this, project risk can be mitigated through proper documentation of technical contracts with the supplier, contractors, and collaborators that clearly lays down the tenets of guaranty in terms of performance, material workmanship, and consumption of raw materials and power. Liquidated damages to be paid by the contractor in the event of a failure in guaranteed performance need to be spelled out. Adequate training by the collaborators for the company's employees who are involved in the project also goes a long-way in reducing performance risk.

In conclusion, project risk management can be effectively implemented if the following-steps are taken:

**Identify project risk at the start of the project** - The initial steps need to identify the risk factors and their relationship with the stakeholders. This can well be done through holding brainstorming sessions among the project team and all other stakeholders when the project plan is developed.

**Analyze the project risk** - The identified project risk is to be analysed using relevant measurement tools. The company-specific risk agenda then clearly shows the probability of occurrence of such risks and the quantified impact thereof. The project team should be fully aware of risk information and the compounding effects of the risk. Choice of analysis method is another important factor so that the risk assessment and measurement is properly estimated.

**Rank the risks** - As the analysis of risk brings out the implication as well as the impact of various project risks, the Pareto method will have to be developed so that critical risks on the basis of ranking are monitored on a continuous basis. Prioritization of risks is done strictly on the basis of computation of seriousness and severity of such risk.

**Respond to deviations in project risk** - Having developed a project plan, identified and analyzed the project risk, the project team knows that any deviations in the project plan, when actually implemented, sow the seeds of project risks. It becomes essential at this juncture to embark on immediate risk responses to obviate the impact of deviations. This are normally done through resource leveling, developing cost slopes, and 'crashing a project', that is, increasing the pace of a project by devoting more resources to it to keep to the original timeframe of the project.

**Track the risk** - During risk analysis for any project, certain risks are found to compound themselves as they impact other lines of activities in a project and lead to a misalignment of the line of balance. Therefore, tracking such risks and associated activities is extremely important. Such tracking can be communicated to all those who are associated with all the activities and affected by such risk on the line or in real time.

**Evaluate and control the risk** - In actual project management, despite all caution and acumen, a project plan can go awry due to changes or revision of assumptions. Monitoring on a continuous basis throws up the chinks in the armor, leading to proper control and repair. This evaluation process is a wholesome process based on a 'totality' approach and keeps the critical path of a project intact.

### **Operational Risk**

It is not easy to assess the levels of operational risk and its sources. Therefore, companies consider operational risk an unavoidable cost of doing business. Companies collect data on operational losses and use these data to develop a model for operational risk. Some companies compute a capital reserve against future operational losses. Based on the requirement of Basel II, Reserve Bank of India has laid down certain accounting procedures to take care of operational risks arising from NPAs. For the purpose of computation of capital for operational risk, Basel II prepared guidelines under three broad methods for banking and insurance sector. These are as follows:



- (1) Basic indicators approach—based on annual revenue of financial institutions
- (2) Standardized approach—based on annual revenue of each of the broad business lines of the financial institutions
- (3) Advanced measurement approaches—based on internally developed risk measurement framework of the bank adhering to the standard prescribed.

The Reserve Bank of India has also developed certain guidelines with respect to operational risk in financial institutions. These are as follows:

- (1) The common equity component as a percentage of total assets should be at 7 per cent in March 2009 for Indian banking sector as against the range of 3 per cent to 4 per cent for large international banks. Total capital to risk asset ratio (CRAR) was 13.75 per cent, with tier 1 banks at 9.4 per cent. Therefore, the Indian banks were in a favorable position to meet the growth requirements. Currently, they have a reasonable period to plan and raise required capital for future and growth.
- (2) The gross NPAs for the banking sector have increased 2.4 per cent as on 31 March 2008 to 2.6 per cent as on 30 September 2009. In the context of rising non-performing assets and likely slippages resulting in operational risk, Reserve bank of India has introduced 70 per cent provisioning coverage ratio for non-performing assets.
- (3) Credit to commercial real estate has been evidencing higher risk perception, especially, in the case of home loans. Reserve Bank of India has set certain limits beyond which the security cover should be 120 per cent and the actual loan will be only to the extent of 80 per cent of the asset value.
- (4) Again, the banking sector has been investing in mutual funds and therefore has to be sensitive to roll-over risks as well as liquidity risk in the event of the need for sudden redemption by large investors at the same time.
- (5) Non banking financial companies who are engaged in microfinance face a risk that arises out of multiple lending and high interest rates leading to deterioration in asset quality. So there is a need for these companies to access the credit quality of these loans by continuous monitoring.
- (6) Securitization of asset by banks is also another area where operational risk is inherent. The RBI is considering norms for minimum intervention requirement and minimum holding for securable loans.
- (7) Even though hedging is resorted to by banks, normally there are also unhedged portions that may translate into severe stress and their asset quality may deteriorate. It is necessary that the unhedged portion be closely monitored and be built into credit and other rating assessment of the borrowers.
- (8) Introduction of technology in banking has brought many benefits but has brought with it an increasing vulnerability to cyber frauds. An appropriate control mechanism needs to be built in to prevent such frauds.

Importantly, stress testing exercises should be undertaken by the banks to alert themselves regarding adverse unexpected result arising out of variety of risks.

Companies, other than financial institutions and others engaged in manufacturing operations, resort to HAZOP study and the asset liability management model. These models assess losses arising from operational risk and recommend proper control to mitigate such losses to the extent possible. Operational risk can be managed either through risk retention or through risk transfer to an expert such as an insurance company.

Risk retention is resorted to by providing adequate reserves to meet losses arising from such eventuality. Risk transfer has been in the form of insuring the probable losses arising out of acts of commission or omission, negligence, and inefficiencies. Insurance covers against breach of faith, loss of profit arising as a consequence of break down in operations are also available as a cover against operational risk.

In conclusion, operational risk is different from the various other risks that are not inherent in the business processes.



# OPERATIONAL RISK MATRIX

**Peabody disaggregates operational risk into subcomponents...**

Operational Risk Subcomponents

<p><b>EMPLOYMENT</b></p> <ul style="list-style-type: none"> <li>● E1 Employee's liability</li> <li>● E2 Workers' compensation</li> <li>● E3 Federal black lung</li> <li>● E4 Employment-practices liability</li> <li>● E5 Employee benefits</li> <li>● E6 Fiduciary liability</li> <li>● E7 Kidnap and ransom</li> <li>● E8 Employee dishonesty</li> <li>● E9 Employee conduct</li> </ul> <p><b>LIABILITY</b></p> <ul style="list-style-type: none"> <li>● L1 Directors' and officers' liability</li> <li>● L2 Aviation liability</li> <li>● L3 General liability</li> <li>● L4 Auto liability</li> <li>● L5 Products liability</li> <li>● L6 Marine liability</li> <li>● L7 Vendor and contractor liability</li> </ul>	<p><b>NATURAL</b></p> <ul style="list-style-type: none"> <li>● N1 Underground property</li> <li>● N2 Surface property</li> <li>● N3 Business income</li> <li>● N4 Contingent business income</li> <li>● N5 Business continuity</li> </ul> <p><b>OPERATIONS</b></p> <ul style="list-style-type: none"> <li>● O1 Joint venture operations</li> <li>● O2 Inventory obsolescence</li> <li>● O3 Key Supplier</li> <li>● O4 Contractor</li> <li>● O5 Equipment availability</li> <li>● O6 Explosive-material safety</li> <li>● O7 Power interruption</li> <li>● O8 Labor interruption</li> <li>● O9 Geological conditions</li> <li>● O10 Safety</li> <li>● O11 Hazardous material and environmental issues</li> <li>● O12 Technology</li> </ul>
---	---

**...and arrays them to reflect degree of exposure and risk transfer**

Operational Risk Matrix

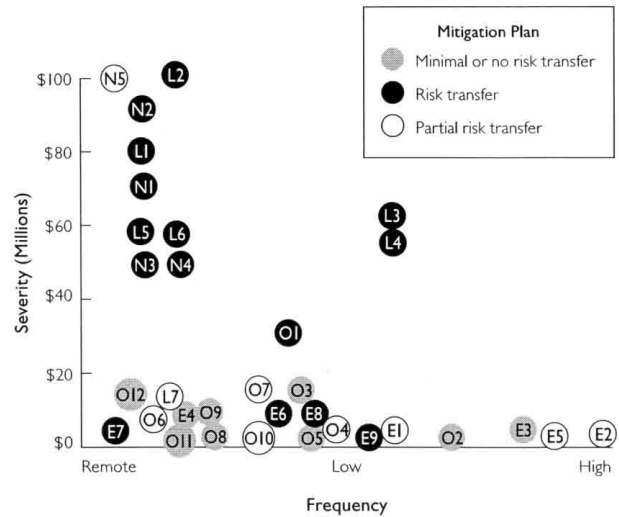

## RISK TOLERANCE FRONTIER

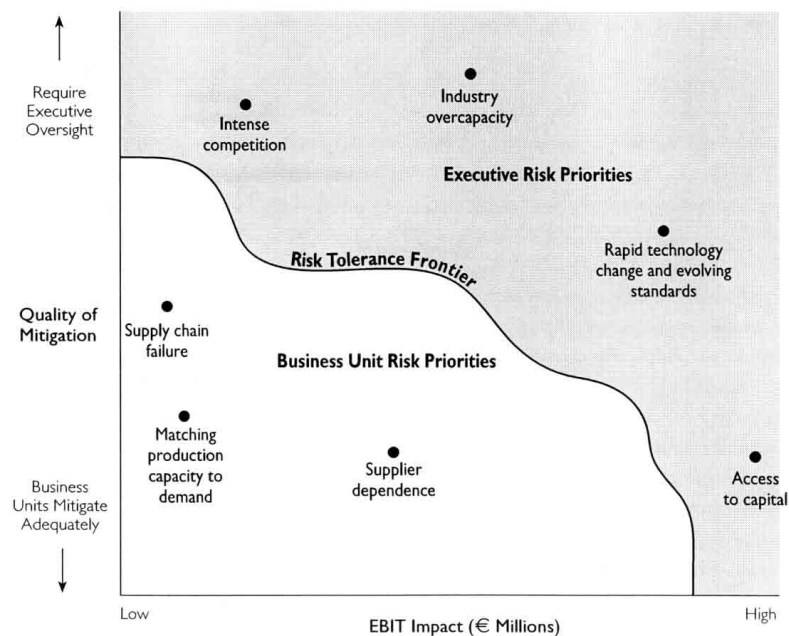





## MAPPING CUSTOMER'S STRATEGY TO IMPLICATIONS ON ITS PURCHASING TRENDS

**Evaluation of customer's strategic directions...**

**...and an estimation of attendant financial and market risks faced by customer...**

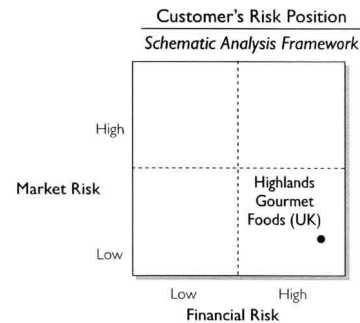
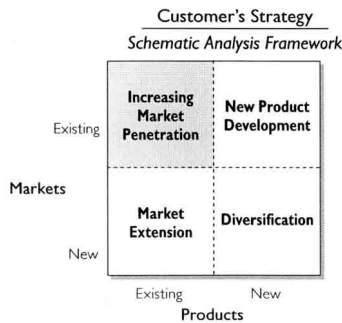

**...informs judgment of customer's purchasing requirements and implied action steps**

Analysis of Customer Purchasing Trends  
Schematic

Customer: Highlands Gourmet Foods (Hypothetical)		Spring 2003
Key Purchasing Trends	Suggested Action Steps	
Customer overextended financially trying to increase market share, likely to impose cost controls which may depress Wessanen's margins	Manage marketing costs and trade discount aggressively, analyze opportunity to enhance Wessanen market share at the cost of unit margins	
Volumes likely to increase for low-end gourmet foods as retail customer penetrates low-end markets	Lower internal production targets for key high-end goods, renegotiate volume discounts with suppliers of inputs to low-end products	
10% gain in market share likely to give customer increased power in pricing negotiations	Tie customer to longer term contracts to mitigate against increased pressure of discounts over time	

## MEASUREMENT FORMULA TO CALCULATE ECONOMIC VALUE OF CURRENT PLAN

### Valuation Methodology – Example – Forecast Shape

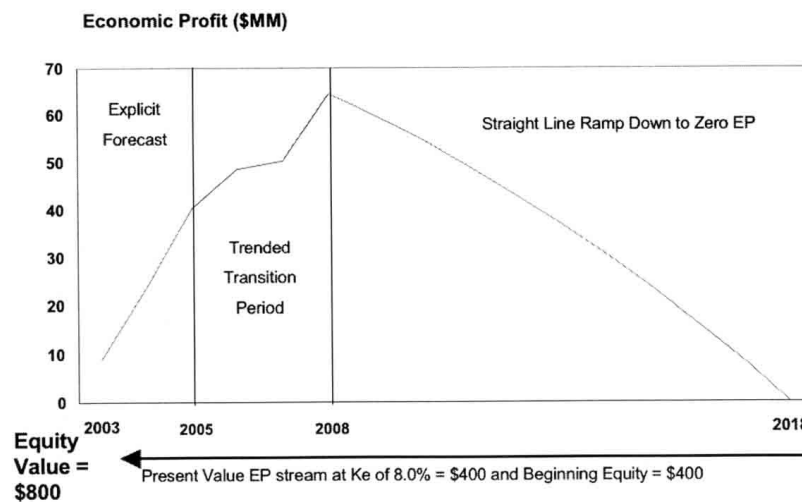

## PERFORMANCE TARGET CALIBRATION

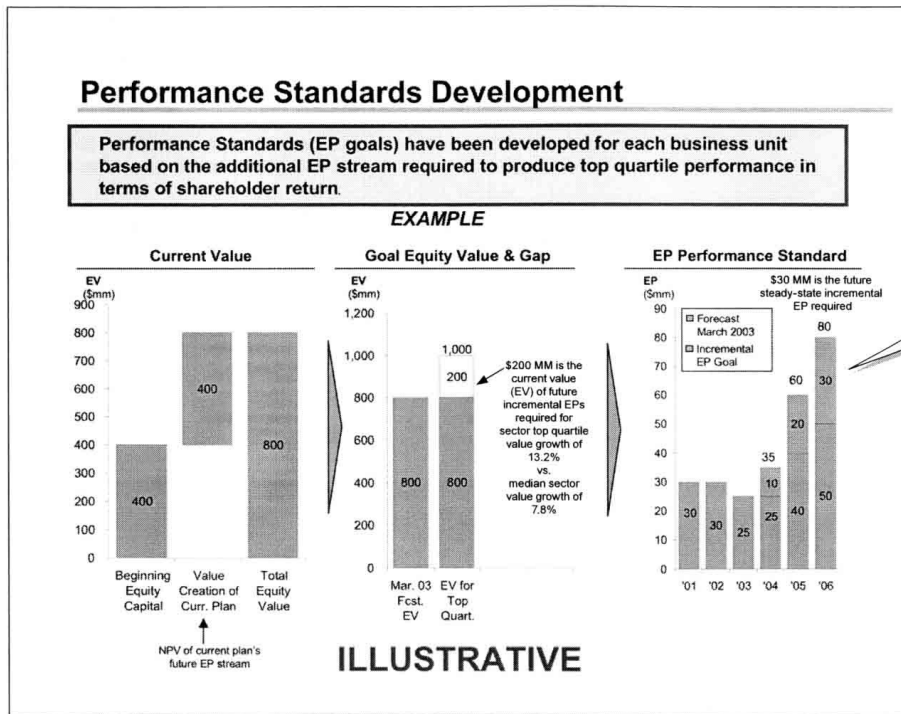

The corporate center gives quantified guidance on the additional performance the BU's new plan must generate

## IT PORTFOLIO MANAGEMENT DASHBOARD

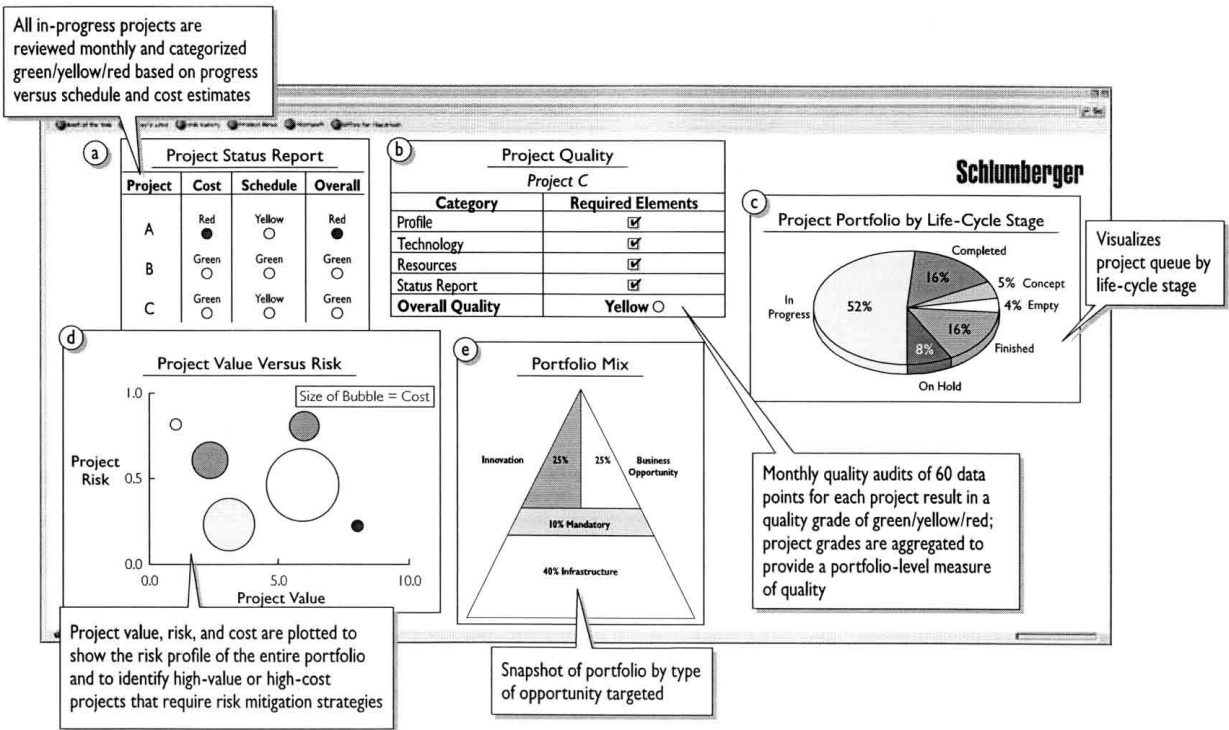

# Study Note - 9

## PERFORMANCE EVALUATION AND CORPORATE FAILURE



### This Study Note includes

- 9.1 Corporate Failure
- 9.2 Application of Generally Accepted Cost Accounting Techniques and Tools for Analyzing Quantitative and Qualitative Performance Measurement
- 9.3 Leading Indicators of Sickness
- 9.4 The Prevalence of Corporate Failure
- 9.5 Causes of Corporate Failure and their examples
- 9.6 Preventing Corporate Failures
- 9.7 Prediction Models Used to Assess Corporate Failure
- 9.8 The Models to Predict Corporate Failure
- 9.9 Performance Improvement Strategies

### 9.1 CORPORATE FAILURE

The major issue arising in the present times, for both management academics and practitioners, relates to the principles which determine corporate successes and failures that is why some organization prosper and grow while other collapse. The often unexpected collapse of large companies during the early 1990's and more recently in 2002 has lead analysts to look for ways of predicting company failure. Corporate failures are common in competitive business environment where market discipline ensures the survival of fittest. Moreover, mismanagement also leads to corporate failure. Predicting corporate failure is based on the premise that there are identifiable patterns or symptoms consistent for all failed firms.

#### 9.1.1 Definition

According to Altman (1993), there is no unique definition of corporate failure. Corporate failure refers to companies ceasing operations following its inability to make profit or bring in enough revenue to cover its expenses. This can occur as a result of poor management skills, inability to compete or even insufficient marketing.

#### 9.1.2 Symptoms of Corporate Failure

There are three classic symptoms of corporate failure. These are namely:

1. Low profitability
2. High gearing
3. Low liquidity

Each of these three symptoms may be indicated by trends in the company's accounts. Symptoms are interrelated. The classic path to corporate failure starts with the company experiencing low profitability. This may be indicated by trends in the ratios for:

- Profit margin
- Return on Capital Expenditure
- Return on Net Assets

A downward trend in profitability will raise the issue of whether and for how long the company can



tolerate a return on capital that is below its cost of capital. If profitability problems become preoccupying, the failing of the company may seek additional funds and working capital by increasing its borrowings, whether in the form of short term or long-term debt. This increases the company's gearing, since the higher the proportion of borrowed funds, the higher the gearing within the capital structure. The increased debt burden may then aggravate the situation, particularly if the causes of the decreasing profitability have not been resolved.

The worsening profit situation must be used to finance an increased burden of interest and capital repayments. In the case of a publicly quoted company, this means that fewer and fewer funds will be available to finance dividend payments. It may become impossible to obtain external credit or to raise further equity funds.

Confidence in the company as an investment may wither away leaving the share price to collapse. If the company is sound, for instance, but ineptly managed, the best that can be hoped for is a takeover bid for what may be now a significantly undervalued investment.

At this point, a company may not be really failing but unfortunately, more often rescue attempts are not mounted. This may be because the company's management does not recognize the seriousness of the situation, or is by now too heavily committed or too frightened to admit the truth to its stakeholders, when refinancing is attempted profits fail to cover payments leading to a cash flow crisis.

What are the causes of corporate failure, and can they be avoided? Numerous studies reveal the alarmingly high failure rate of business initiatives, and corporate survival rates have recently declined across the major European economies. This article examines the range of explanations for failure, before considering whether failure can sometimes even be 'good'.

After addressing growth strategies in the last Henley Manager Update, we'll now review recent writing on corporate failures. What are the causes of company failure and how can these be stopped? In what ways can companies learn from failure? Of course, not all failures in business actually lead to the failure of the business. There are, though, many examples in recent times of growth strategies that failed. Unilever, for example, embarked upon its well-publicised Path to Growth strategy in 2000. Since then, it has not only failed to grow profitably but has also seen its European sales decline. Part of the problem was in not being quicker to address emerging market trends, such as the one for low-carb diets. Similarly, Volkswagen embarked on a burst of growth in the late '90s by acquiring other well-known automobile brands, only to find these began competing against each other as competition intensified by the middle of this decade.

## 9.2 APPLICATION OF GENERALLY ACCEPTED COST ACCOUNTING TECHNIQUES AND TOOLS FOR ANALYZING QUANTITATIVE AND QUALITATIVE PERFORMANCE MEASUREMENT

The compilation of Generally Accepted Cost Accounting Principles (GACAP) is unique. There have been compilations of financial accounting principles such as Paul Grady's work. ("Inventory of generally accepted accounting principles", American Institute of Certified Public Accountants, New York, 1961). While cost data is being used by various stakeholders, the focus has been more on management use. The absence of institutionalization of external cost reporting might explain this lacuna in theory. The Cost Accounting Standards issued by the Cost Accounting Standards Board in the United States is the nearest to such compilation but this is in the context of Defence Contract Costing.

The formalization of Cost Accounting Principles in use in India started acquiring a more cohesive form in the regime of administered prices ushered in the 1950 through the work of Tariff commission mandated to fix tariffs and prices in a variety of industries. The movement acquired further fillip through the work of other statutory price-fixing authorities including the Bureau of Industrial Costs and Prices, Ministry of Finance, (Cost Accounts Branch). Since the price enquiries by these bodies covered a wide range of industries, industry specific practices started unifying into a common body of cost accounting principles.

The introduction of the industry-wise Cost Accounting Record Rules further strengthened the evolution of



a uniform body of cost accounting principles. Even though intended to prescribe the Cost Accounting records to be maintained by various industries, the Rules carried nuggets of Cost Accounting principles in the body of the Rules and in footnotes to format of cost statements prescribed. When some of these got repeated in the Rules prescribed for different industries, it helped towards the evolution of a generally accepted set of cost accounting principles. Thus the Rules contained directions on valuation of purchased materials (all direct costs up to the works), the treatment of major repairs (to be prorated over the period benefited by such repairs), the costing of transfers of raw materials from own farms (sugar cane at government controlled price) and the like. This is not to deny that the Rules framed from time to time did have contradictions for example the valuation of sugarcane from own farm to be valued at market price and valuation of wood from own forest to be valued at cost) but the Cost Accounting Record Rules did play a major part in unifying cost accounting principles as applied to various industries.

Similarly the regulatory agencies in charge of individual industries, particularly the Fertilizer Industry Co-ordination Committee, the Drug Price Control Authority, the Central Electricity Regulatory Commission, Telecom Regulatory Authority of India- all played a role in evolving a more consistent set of cost accounting principles.

The Cost Audit Report Rules as amended from time to time did not lay down any cost accounting principles as such but by requiring disclosure of principles and methods used, it focused attention on them. The amendment of the Rules in 2001 prescribing a single proforma for cost reporting for all industries was a landmark event. It ushered in "General Purpose Cost Statement", which is unique in the global practice of cost accounting.

The requirement for determination of cost of production of manufactured goods used for captive consumption further focussed attention on the subject of GACAP. According to the Central Excise Valuation (Determination of Price of Excisable Goods) Rules, 2000, the assessable value of goods used for captive consumption is 110% of cost of production of such goods, or as may be prescribed by the Government from time to time. The cost accounting principles for determination of cost of production were also well established. Their codification and standardization in a single document viz. Cost Accounting Standard 4 (CAS 4) issued on January 3, 2003 became a landmark event. The standard contains a format for reporting the cost of production of products manufactured. The Certificate at the end of the format carried a reference to the basis being "Generally Accepted Cost Accounting Principles and Practices". Thus was born the phrase forming the title of this document.

The present effort of codifying the GACAP and presenting them in a single volume is the culmination of all the above developments in the practice of cost accounting in India.

Whereas Cost Accounting Standard 4 (CAS 4) issued in 2003 focused attention on GACAP, The Companies (Cost Accounting Records) Rules, 2011 which require maintenance of cost records according to Cost Accounting Standards and GACAP gave the mandate for a compilation of GACAP. Moreover, the supersession of the erstwhile industry-wise detailed Rules providing guidance on cost accounting principles and practices to be followed by the companies further necessitated the issuance of this document.

The objectives of this document are;

1. to codify the GACAP as applied in the Indian industry;
2. to narrow down diversities in cost accounting practices facilitating the process of development of cost accounting standards;
3. to provide a reference source to industry and practitioners in preparation and attestation of Cost Statements, where specific cost accounting standards are yet to be issued;
4. to provide a reference source to all the stakeholders in the understanding and interpreting the cost statement;
5. to provide a base for monitoring the evolution of new concepts and practices in cost accounting and to codify them as and when they become generally accepted;

As per Cost Audit Report Rules, 2011, the following Form III – prescribes the Performance Appraisal Report as follows:

Explanatory Statement on the preparation of Form III - Performance Appraisal Report

Issues	Areas suggested for evaluation
<b>1. Capacity Utilization Analysis</b>	<b>Capacity Utilization Analysis along with estimated impact on costs and profitability</b> (Product-wise, Product Group-wise and Unit-wise) <ul style="list-style-type: none"> <li>➤ Under-utilization of Capacities</li> <li>➤ Idle Capacities</li> <li>➤ Non-Productive Assets</li> <li>➤ Trend Analysis</li> <li>➤ Opportunity Analysis</li> <li>➤ Outsourcing/Sub-Contracting Vs. Internal Capacities</li> <li>➤ Plant Break-down hours with impact on productivity, costs and profitability</li> <li>➤ Scope of Expansion and likely cost-benefit analysis</li> </ul>
<b>2. Productivity Analysis</b>	<b>Productivity Analysis along with estimated impact on costs and profitability</b> (Product-wise, Product Group-wise and Unit-wise) <ul style="list-style-type: none"> <li>➤ Production/Operations/Process Cycle Time and Productivity</li> <li>➤ Input-Output Analysis compared with Budgets or Standards or Industry Norms</li> <li>➤ Conversion Efficiency Analysis</li> <li>➤ Cost of wastages in operations</li> </ul>
<b>3. Utilities/Energy Efficiency Analysis</b>	<b>Utilities/Energy Efficiency Analysis</b> (Utility-wise, Unit-wise, Product-wise, and Product Group-wise) <ul style="list-style-type: none"> <li>➤ Utility Productivity compared with Budgets or Standards or Industry Norms</li> <li>➤ Input-Output Efficiency – impact on costs and profitability</li> <li>➤ Energy Conversion Ratio highlighting wastage &amp; inefficiency</li> <li>➤ Energy Consumption Ratio for each product/operation and each product/activity group compared with Budgets or Standards or Industry Norms</li> </ul>
<b>4. Key-Cost &amp; Contribution Analysis</b>	<ul style="list-style-type: none"> <li>➤ Key-Expense Ratios vs. Cost of Production / Cost of Sales</li> <li>➤ Abnormal &amp; Non-Recurring Costs – impact on profitability</li> <li>➤ Key Costs Trend Analysis indicating estimated impact on future profitability</li> <li>➤ Cost-effectiveness Analysis: Cost of Operation/Process vs. Benefits</li> <li>➤ Cost of Management vs. Net Turnover or Gross Margin or Net Margin</li> <li>➤ Cost Variance Analysis vs. Standards or Budgets – impact on profitability</li> <li>➤ Volume Variance Analysis vs. Standards or Budgets – impact on profitability</li> <li>➤ Marginal Cost and Contribution Analysis for each product/activity, each product/activity group, each market segment, each customer segment, etc.</li> <li>➤ Service Department-wise cost trends (element-wise)</li> </ul>
<b>5. Product/Service Profitability</b>	Product/Service Profitability (for key products/services only) – Product, Turnover, % to Total, Capital Employed, % to Total CE, Gross Margin, % to Total, GM/Turnover, GM/CE, Net Margin, % to Total, NM/Turnover, NM/CE, FE Variation Impact, Derivatives Impact, etc.

<b>6. Market/Customer Profitability</b>	<p>Market/Customer Profitability – similar analysis as above</p> <ul style="list-style-type: none"> <li>➤ Market Distribution – Indigenous vs. Overseas broken into smaller geographical divisions/segments</li> <li>➤ Customer Distribution – in order of percentage share in each product/activity and in each product/activity group</li> <li>➤ Indicate cost of servicing each market/customer and its efficiency in terms of business, contributions, gross/net margins, scope of sustainability, etc.</li> <li>➤ Indicate cost of each supply chain vs. benefits</li> <li>➤ Indicate impact of FTAs and Dumping on each product, product-group or each market/customer.</li> </ul>
<b>7. Working Capital Analysis</b>	<ul style="list-style-type: none"> <li>➤ Movement of Debtors vs. Credit Sales</li> <li>➤ Days Debtors Analysis – impact on cash flow and profitability</li> <li>➤ Overseas Debtors – impact of likely FE Variations</li> <li>➤ Movement of Creditors vs. Credit Purchases</li> <li>➤ Days Creditors Analysis – impact on supplies and product-line</li> <li>➤ Inventory Turnover</li> <li>➤ Cash Flow Turnover – impact on profitability</li> </ul>
<b>Inventory Analysis</b>	<p>Inventory Analysis - Basis of valuation &amp; Consistency</p> <ul style="list-style-type: none"> <li>➤ Turnover efficiency: Cost of Goods Sold/Average Inventory</li> <li>➤ Return on Inventory: GM/Average Inventory, NM/Average Inventory</li> <li>➤ Slow-moving or dead inventory</li> <li>➤ ABC analysis; Period holding analysis</li> <li>➤ Policy for Insurance Spares; Inventory Holding due to changes in technology, changes in production process, obsolescence, etc.</li> </ul>
<b>8. Manpower Analysis</b>	<p><b>Manpower Analysis</b> (Function-wise, Unit-wise, Product-wise, and Product Group-wise)</p> <ul style="list-style-type: none"> <li>➤ Manpower Productivity vs. Returns compared with Budgets or Standards or Industry Norms</li> <li>➤ Manpower Pyramid – Ratio of Top Management to Middle Management to Officers to Workmen to Contract Labour</li> <li>➤ Idle Man-hours to Total Man-hours with reason-wise analysis and impact on productivity, costs and profitability</li> <li>➤ Manpower Absenteeism Vs. Total paid Man-days</li> <li>➤ Cost of Manpower Pyramid Analysis – broken into broad categories (including contract labour)</li> <li>➤ Cost of Training to Total Employee Cost</li> </ul>

<p><b>9. Impact of IFRS on the Cost Structure, Cash Flows and Profitability</b></p>	<p><b>Impact of IFRS on the Cost Structure (element-wise)</b></p> <ul style="list-style-type: none"> <li>➤ Due to change in the recognition of Incomes</li> <li>➤ Due to change in the recognition of Expenses</li> <li>➤ Due to change in the valuation of Assets</li> <li>➤ Due to change in the valuation of Liabilities</li> <li>➤ Due to change in the valuation of Inventories</li> <li>➤ Due to change in the valuation of Future Financial Obligations</li> <li>➤ Due to change in the treatment of either Incomes or Expenses</li> <li>➤ Due to change in the treatment of Intangible Assets or Liabilities</li> </ul>
<p><b>10. Application of Management Accounting Tools</b></p>	<p><b>Management Accounting Tools</b> – use of modern management accounting tools and techniques such as :-</p> <ul style="list-style-type: none"> <li>➤ Activity Based Costing,</li> <li>➤ Target Costing</li> <li>➤ Lifecycle Costing</li> <li>➤ Quality Costing</li> <li>➤ Value Engineering</li> <li>➤ Supply Chain Management</li> <li>➤ Balanced Scorecard</li> <li>➤ Performance Pyramid</li> <li>➤ Lean Accounting</li> <li>➤ Theory of Constraints</li> <li>➤ Throughput Accounting</li> <li>➤ Kaizen Costing</li> <li>➤ Customer Valuation</li> <li>➤ Strategic Cost Management, etc. and benefits availed, if any.</li> </ul>

### 9.3 LEADING INDICATORS OF SICKNESS

Just as diseases are identified by certain symptoms, industrial sickness can be identified by the following symptoms. These symptoms act as leading indicators of sickness, and if immediate remedial actions are not taken, the sickness will grow to the extent that the organization will find its natural death.

- Continuous reduction in turnover.
- Piling up of inventory,
- Continuous reduction of net profit to sales ratio.
- Short term borrowings @ high interest rate,
- Continuous cash losses leading to erosion of tangible net worth,
- Default in payment of interest on borrowings and default in repayment of term loan instalments.
- The 'sundry debtors' as well as the 'sundry creditors' keep growing and reaching a disproportionately high level.
- Approaching the banker for temporary overdraft at frequent intervals.
- High turnover of personnel, especially at senior levels,
- Change in accounting procedure with a view to window dressing.
- Delay in finalization of accounts

## Do successful growth strategies automatically lead to a boost to profits?

Not necessarily. As Greenwald and Kahn (2005) point out in a recent article, multinational media giants like Disney, Viacom and Time Warner often posted spectacular annual revenue growth in the decade between 1994 and 2004, while the low accompanying shareholder returns indicated that in fact, they weren't generating true shareholder value. Why? The authors maintain that companies operating in global markets are often destined to have lower returns than more traditional companies operating in 'local markets'. They contrast the performance of these big media companies with traditional US newspaper companies, whose revenue growth was much more modest, but who managed to generate positive shareholder returns over the same period.

The authors' definition of local, though, may not necessarily be that of most people. They define markets as local, both in the literal geographic sense of the term but also in the sense of markets limited to a single product or handful of related products. Competitive advantage, they argue, occurs through capturing customers, proprietary technology or economies of scale which are easier in narrow local markets than on a global scale.

Thus, if advantage depends on economies of scale - and this requires a producer to operate above a certain level of production - this minimum efficient scale is more likely to be achieved in large-scale markets. In a restricted market, on the other hand, economies of scale are much less easy to achieve, as they tend to require a much larger percentage of the market. This can be difficult to reach without competing against incumbents. Indeed, they would maintain that many sustainable sources of advantage are based upon local or regional presence, even in industries such as retail, pharmaceuticals and consumer goods, which are ostensibly global. Moreover, more and more of what we purchase is made up of services rather than products and as services tend more often to be provided on a local basis, so strategy and competitive advantage will increasingly depend on a local presence.

### 9.4 THE PREVALENCE OF CORPORATE FAILURE

Many corporate observers need no reminding of the failure rate of business initiatives such as acquisitions, business process re-engineering or diversification. But, as Paul Ormerod (2005) reminds us: "Failure is the most fundamental feature of both biological systems and human social and economic organisations. Of all the species that have ever existed 99.99 per cent have failed in the most dramatic way. They are extinct. In America, more than 10 per cent of all companies fail every year, with more than 10,000 closing every week."

Knott and Posen (2005) argue this 10 per cent figure needs perspective, as 11 per cent of existing firms in the US are new each year, so the overall stock is actually growing at a net rate of 1 per cent. Moreover, failure is disproportionately skewed towards newer Corporate failure and younger companies. In the US, for example, 51 per cent of firm exit the market within the first four years of their life and there would appear to be a well-established relationship between the age and size of an organisation and its risk of failure.

According to Sheth and Sisodia (2005) corporate life expectancy across major European economies has declined in recent years. In Germany, for example, it's dropped to 18 years from 45, in France to 9 from 13 and in the UK to 4 from 10 years. While, they say, much of this is because of mergers and acquisitions, they argue many of the acquisitions themselves are prompted by corporate failure or, to use their expression, 'distressed selling rather than strategic buying'. No doubt to the chagrin of consultants and advisors worldwide, they argue many companies succeed by accident rather than design. Take, for example, the early business histories of many now well-established corporations. They cite the example of Microsoft, whose current world dominance owed much to the success of MS-DOS, an operating system which the infant Microsoft provided for IBM in the early '80s after first acquiring it from a local software company for a trivial sum and re-branding it as a Microsoft product.

Companies succeed because by chance or circumstance their internal capabilities and assets seem to match the opportunities in the environment at that particular time. As such, they can just as easily fail if they prove unable or unwilling to change their culture, processes, systems and structure. This phenomenon, variously described as the dominant logic, active inertia and blind spots, is the prime cause for decline and failure, the authors argue. Sheth and Sisodia also believe that companies which focus on the narrow interests of a few stakeholders at the expense of others are unlikely to achieve long-term success. In the long run, they argue, success generally requires the engagement both in a material sense - and on an emotional basis - of the organisation's key stakeholders.

Other reasons for failure include changes to the environment, including six prime 'change drivers' affecting the business landscape with varying degrees of speed and impact, the authors say. Interestingly, they believe that many companies focus too much on technology and globalisation as the prime drivers for change. While these are clearly important, it is generally faster moving external forces like regulation, capital markets and competition which have the most impact upon a company's ability to survive or fail. When facing major seismic shifts in a company's business environment, companies that continue to practice so-called status quo management are doomed, Sheth and Sisodia argue. Instead they urge 'anticipatory management' which may be fine as a concept but much more difficult in practice. This approach requires not only anticipating trends in advance but also launching major changes in structure, systems and processes in an organisation which is currently performing acceptably.

### **Sure Ways to Lose Your Competitive Advantage**

Ma and Karri (2005) argue that top management generally bears the main responsibility for corporate failure, usually through ignorance of their own sources of competitive advantage, gross negligence, arrogance, overconfidence and self-aggrandisement. Major environmental shifts are also caused by pure bad luck, e.g. through acts of God like hurricanes or terrorist activity like September 11th, both of which can impact companies and their ability to survive in unpredictable but serious ways. Again, the key to mastering such shocks would appear to lie in proactive anticipation and constant self-critical questioning. 'Only the paranoid survive', as Andy Grove, founder of Intel, famously once said.

### **Strategy as Active Waiting**

For Donald Sull (2005), it is companies' actions during lulls between the periods of radical change that can determine their long term success. He argues that major changes, whether they are 'golden opportunities' or 'sudden death threats' are relatively rare events that occur just once or twice a decade. Given their relative infrequency, Sull argues, companies should engage in a strategy of so-called 'active waiting': 'Like an advancing army, a company proceeding into an unpredictable future can follow a general direction, probe the future for potential opportunities and threats, keep resources in reserve, remain battle ready, and, when the big opportunity or threat arises, strike hard.'

Thus, in addition to engaging in small-scale experimentation and other grass roots initiatives, companies in periods of calm and stability should maintain relentless pressure on operational excellence, cutting costs and improving efficiency wherever possible. They should also build up a war chest to deploy rapidly in the face of either major opportunity or a sudden death threat to their existence. This clearly supports the idea that companies which are well-established and resource rich are better able to weather potential sources of failure when they arise.

### **Organisational Failure as Failed Turnaround**

To Sheppard and Chowdhury (2005) corporate failure is not about the environment or the organisation per se, but rather about a failure of alignment between the organisation and its environmental realities. Since an organisation generally has the time and opportunity to make adjustments when a misalignment occurs - through, for example, a turnaround strategy - organisational failure must therefore by definition stem from a failure to successively implement the turnaround. Even in industries that are subject to radical unforeseen shocks, such as the airline industry after 9/11, there were some companies which were able to adjust and others which went out of business because they were not properly positioned

in the industry or because their turnaround strategies were ineffective, the authors argue.

These authors have developed a four-stage sequential model of the turnaround process. In the first stage, performance declines, leading into the next stage where corrective action is taken in response to the perceived reduction in performance, and to a third transitional stage during which all the necessary actions to effect a turnaround have to be put in place. In the fourth and final stage, the outcome of these interactions becomes apparent and leads either to a turnaround or corporate failure.

They illustrate this model by reference to the Canadian retail industry, highlighting in particular the demise of T. Eaton Co. Ltd., a very well-established Canadian department store which dominated its market for 130 years, only to succumb to competitive pressures in the late '90s. The Eaton story is a familiar one to followers of retail stores on both sides of the Atlantic. The company's position, once supreme in Canada, was eroded by speciality niche competitors on the one hand and new entrants piling aggressively into the bottom end of the market on the other. Attempts to address emerging segments generally resulted in the loss of its traditional customer base.

Eaton's decline proved unstoppable in part because it failed to act radically or quickly enough during the second stage of the turnaround process. Management failed to perceive the gravity of the situation or was unable to cull enough underperforming stores or failed to raise sufficient new capital quickly enough to refurbish and revamp the remaining stores and reposition the company for success. The company eventually went into receivership in 1999 and lingered on for a few years as a brand within the Sears' empire, before finally disappearing in 2003.

At first blush the most striking aspect of the story is how a company that once dominated its market - and was the largest privately held department store chain in the world - could go bankrupt. More interestingly, perhaps though, is that it took the company over 50 years to fail: 'Such a long time span supports the academic insight and conventional wisdom that symptoms of decline, and eventual failure, start appearing many years before the failing firm's ultimate death.' The other main insight in this study is that to arrest long term decline, turnaround actions need to be taken as early as possible and be sufficiently aggressive to provide a temporary breathing space, thus allowing the company to build a platform for longer term strategies. Leave the short term turnaround actions too late, and decline can turn into an ever-descending spiral from which any return is unlikely.

### **The Role of Boards in Failing Organisations**

For Kamel Mellahi (2005) the focus of responsibility for failing organisations lies with top management. Mellahi has also developed a four-stage model of corporate failure but based around the behaviour of company boards. The stages pass from conception, when the seeds of the crisis are sown, through early strategic errors, through the warning signals stage, where the initial mistakes were compounded with other failed strategies, through the rebellion stage, where in response to sharp decreases in the company's share price the board challenges the CEO and his decisions. The final stage is collapse where performance deteriorates markedly and ultimately leads to bankruptcy.

Mellahi illustrates this model with an unusual research approach investigating the fate of HIH, which until 2001 was Australia's second largest insurance company and in that year became the largest corporate failure in the history of Australia. The very prominence of HIH and the wide impact of its demise prompted the establishment of a Royal Commission to investigate its collapse. It is the copious volumes of data collected by this Royal Commission which provide the material for Mellahi's research and the development of the model.

This approach is used to test two theoretical approaches to corporate failure. The first is called prospect theory, which holds that in the face of a threatened failure managers become more prone to taking risk: like gamblers, the more they lose the wilder their betting behaviour becomes, so that disaster is often reinforced and commitment to a failing course of action is escalated.

The second theoretical perspective is known as "threat - rigidity effect theory". This holds that in the



face of a threatening situation like a crisis, managers become paralysed and cling to the status quo or outmoded 'rules of thumb'. In both cases the role of a board of directors is to act with vigilance to prevent either excessively risky behaviour on the one hand, or the challenge of corporative inertia on the other hand.

Mellahi was able to find evidence to support both these theories in the HIH case. In particular, it seemed to support the notion that as companies get further and further into trouble, the CEOs power to control the board increases and the board's ability to influence events drastically decreases. He offers some positive recommendations from the research, albeit not ones that are easy to implement! Boards of directors should be vigilant in looking for early warning signals of trouble. They should actively seek out business warning signals rather than waiting for them to spring to their notice. 'Groupthink' should be actively combated by encouraging contention in the board and limiting the number of years board members can serve. 'Knowledge malnutrition' - where directors have insufficient knowledge about the company to take an informed view of the risks involved - should be actively combated. Mellahi urges independent views to be sought before major strategic decisions like acquisitions.

### **Creative Errors and Heroic Failures**

Yet not all failures in business are necessarily catastrophic, as Kriegesmann et al (2005) point out in their recent article. While there is a rhetorical commitment in many organisations to innovation and change, often behaviours and policies can induce risk averse behaviour, stifling the very innovation which companies seek to promote. Certainly there are many types of error in business, which should not be tolerated, particularly if a series of errors occurs through the inability or unwillingness of individuals or managers to learn from their experience. On the other, there are other types of errors or failures - such as those that occur through changing circumstances, so called 'system errors', or what the authors call 'creative errors' or 'successful failures' - with manageable and calculated risks. They illustrate their ideas with an example from BMW in Germany, where in one plant a 'Creative Error of the Month' award was established to enable people to bring forward well considered initiatives with calculated risk analysis attached to them and create an opportunity to learn in a blame free environment, even in the event that the innovation does not succeed.

Unfortunately, if Baumard and Starbuck (2005) are to be believed, organisations prove depressingly incapable of learning from small failures and, if anything, even less from large failures! Indeed, they contend that even when learning does occur it often teaches companies the wrong lessons. The authors illustrate the point with their longitudinal research into both large and small failures in large multi-divisional European telecommunications companies.

Such businesses, they conclude, are intensely political and thus managers interpret failures to bolster their own power positions. 'Managers agreed to try experiments that did not challenge their core beliefs, and accordingly, the experiments propagated the core beliefs. Failed experiments became ideological playgrounds where people sought new ways to reinforce existing beliefs about past successes...managers interpreted the small failures as demonstrating the foolishness of attempts to deviate from the firm's core beliefs'. Thus, far from stimulating innovation, the small-scale experiments actually prevented testing of fundamental assumptions about the business.

Evidence that contradicted core beliefs was often discarded and experiments chosen that were likely to sustain beliefs. Large failures, if anything, supported even less learning than the small ones, since large failures were almost always attributed to exogenous causes and not managerial actions.

### **Is Failure Good?**

As already mentioned, the vast majority of all new firms fail. Generally, the literature on entrepreneurship, from Schumpeter onwards, has interpreted this as the inevitable, if regrettable, by-product of the process of creative destruction. The literature on innovation holds that successful entrepreneurs will provide economic benefits by satisfying existing needs or even creating new consumer needs.

Could unsuccessful ventures, even though they may be failures individually, also have a generally



positive impact on the public good? It is well-known that the airline and rail industries, for example, which have often failed over decades to generate shareholder value, have enabled the creation of a vast range of associated industries which have generated enormous economic and social benefits. Knott and Posen (2005) test their hypothesis that failure can be good by examining the US banking industry. They found evidence to support the three different mechanisms for promoting benefits from failed companies identified in the literature:

- The 'selection' effect, which holds that firms who survive from a large population of companies ought to be intrinsically better performers than those that survive from a smaller population because the excess entry of competitors in any industry will tend to yield ultimately superior survivor companies.
- The 'competition' effect, which holds that competition amongst companies leads to competitive pressures to innovate; and
- The 'spillover' effect, which holds that the value of investments made by failed companies is subsequently appropriated by survivor companies through, for example, benefiting from investments in training, R&D and marketing.

According to Baumard and Starbuck, companies which prove resolutely resistant to learning from their own failures can, paradoxically, benefit significantly from the failure of other companies, as demonstrated by Knott and Posen's research.

## 9.5 CAUSES OF CORPORATE FAILURE AND THEIR EXAMPLES

### 1. Technological Causes

Traditional methods of doing work have been turned upside down by the development of new technology. If within an industry, there is failure to exploit information technology and new production technology, the firms can face serious problems and ultimately fail.

By using new technology, cost of production can be reduced and if an organization continues to use the old technology and its competitors start using the new technology; this can be detrimental to that organization. Due to high cost of production, it will have to sell its products at higher prices than its competitors and this will consequently reduced its sales and the organization can serious problems.

This situation was seen in the case of Mittal Steel Company taking over Arcelor Steel Company. Arcelor Steel Company was using its old technology to make steel while Mittal Steel Company was using the new technology and as a result, Mittal Steel Company was able to sell steel at lower price than Arcelor Steel Company due to its low cost of production. Arcelor Steel Company was approaching corporate failure and luckily, Mittal Steel Company merged with Arcelor Steel Company and became Arcelor Mittal Steel Company, thus preventing Arcelor from failure.

### 2. Working Capital Problems

Organizations also face liquidity problems when they are in financial distress. Poor liquidity becomes apparent through the changes in the working capital of the organization as they have insufficient funds to manage their daily expenses.

Businesses, which rely only on one large customer or a few major customers, can face severe problems and this can be detrimental to the businesses. Losing such a customer can cause big problems and have negative impact on the cash flows of the businesses.

Besides, if such a customer becomes bankrupt, the situation can even become worst, as the firms will not be able to recover these debts.

### 3. Economic Distress

A turndown in an economy can lead to corporate failures across a number of businesses. The level

of activity will be reduced, thus affecting negatively the performance of firms in several industries. This cannot be avoided by businesses.

The recent economic crisis in the USA led to many cases of corporate failures. One of them is the insurance AIG insurance company. It is facing serious problems and it might close its door in the near future.

#### **4. Mismanagement**

Inadequate internal management control or lack of managerial skills and experience is the cause of the majority of company failures. Some managers may lack strategic capability that is to recognize strengths, weaknesses, opportunities and threats of a given business environment. These managers tend to take poor decisions, which may have bad consequences afterwards.

Furthermore, managers of different department may not have the ability to work closely together. There are dispersed department objectives, each department will work for their own benefits not towards the goal of the company. This will bring failure in the company. One example can be WorldCom, where the finance and legal functions were scattered over several states and communication between these departments were poor.

#### **5. Over-expansion and Diversification**

Research has shown that dominant CEO is driven by the ultimate need to succeed for their own personal benefits. They neglect the objective set for the company and work for their self-interest. They want to achieve rapid growth of the company to increase their status and pay level. They may do so by acquisition and expansion.

The situation of over expansion may arise to the point that little focus is given to the core business and this can be harmful as the business may become fragment and unfocused. In addition, the companies may not understand the new business field. Enron and WorldCom can be an example for this situation where the managers did not understand how growing overcapacity would influence its investment and therefore did not comprehend the risks associated with it.

#### **6. Fraud by Management**

Management fraud is another factor responsible for corporate collapse. Ambitious managers may be influenced by personal greed. They manipulate financial statements and accounting reports. Managers are only interested in their pay checks and would make large increase in executive pay despite the fact that the company is facing poor financial situation. Dishonest managers will attempt to tamper and falsify business records in order to fool shareholders about the true financial situation of the company. These fraudulent acts or misconduct could indicate a serious lack of control. These frauds can lead to serious consequences: loss of revenue, damage to credibility of the company, increased in operating expenses and decrease in operational efficiency.

#### **7. Poorly Structured board**

Board of Directors is handpicked by CEO to be docile and they are encouraged by executive pay and generous benefits. These directors often lack the necessary competence and may not control business matters properly. These directors are often intimidated by dominant CEO and do not have any say in decision making. Example Enron and WorldCom where poorly structured board was a contributor towards their failure.

#### **8. Financial Distress**

Firms that become financially distressed are found to be under- performing relative to the other companies in their industry. Corporate failure is a process rooted in the management defects, resulting in poor decisions, leading to financial deterioration and finally corporate collapse. Financial distresses include the following reasons also low and declining profitability, investment Appraisal, Research and Development and technical insolvency amongst others.



A firm may fail, as its returns are negative or low. A firm that consistently reports operating losses probably experiences a decline in market value. If the firm fails to earn a return greater than its cost of capital, it can be viewed as having failed. Falling profits have an obvious link with both financial and bankruptcy as the firm finds it is not generating enough money to meet its obligations as they fall due.

Another cause that will lead the company to fail is the investment appraisal. Many organizations run into difficulties as they fail to appraise investment projects carefully. The long-term nature of many projects means that outcomes are difficult to forecast and probabilities are usually subjective. "Big project gone wrong" is a common cause of decline. For example, the acquisition of a loser company, this has happened in the case for the failure of Parmalat Co Ltd of Italy, which made the acquisition of several losses making a company where inappropriate evaluation of the acquired company, its strengths and weaknesses.

### 9.5.1 Causes of Sickness for a Project

"Prevention is better than cure" is the proverb that reflects the need for knowing the likely causes of industrial sickness so that one can plan to avoid the same. Just as human beings fall sick by two ways, viz., either born sick or acquiring sickness during growth, an industry can either run into trouble even during the implementation stage itself or develop sickness during its lifetime.

The causes of sickness can be categorized into two viz., internal causes and external causes. Internal causes are those that are internal to the organization over which the management of the organization has control. Sickness due to internal causes can be avoided if the management is shrewd enough to identify the causes and eliminate them at their initial stage itself. External causes are those that are external to the organization over which the management of the organization has little control. Government's plans and actions, failure of monsoon which affects agriculture and allied industries, emergence of strong competitors etc., are some of the external factors. Though sickness may be caused either by internal or external factors, sometimes, the management may be able to revamp its organization, plan suitable strategies and take on the external factors to reduce their impact.

The areas/stages in which these causes may exist and their effects can be studied under the following heads.

- Project formulation.
- Project implementation.
- Production.
- Marketing.
- Finance.
- General and personnel administration.

**Project Formulation:** Most of sickness is attributed to ill-conceived projects. A project that may, prima-facie present a rosy picture may have many hidden pitfalls. Irrational, hasty, over-optimistic decisions may result in choosing projects that may have inherent weaknesses. A project that has an inherent weakness is very unlikely to be a successful project. The existence of a few players in the chosen field who are doing well, is not always a sound proof that the project will be a success. The existing players may have their own special advantages due to which they could have overcome the hurdles and pitfalls that are present in the project.

A thorough investigation of the project during the identification and formulation stage is the sine-qua-non of any project proposal. "Think before you act"—is the proverb that is worth practising. Any amount of time and efforts spent at this stage is worth it as any hasty decision made at this stage will be very costly.

External factors play a major role in project formulation stage. The present stage of and the future course of the external environment are to be carefully studied for their influence on the project

**Project Implementation:** Delayed implementation gives a project a difficult start. Unduly long time taken for project implementation results in time-overrun which is invariably followed by cost-overrun. Cost-overrun has the ill effect of affecting the financial viability of the project since a project that is viable at a capital cost of say ₹ 100.00 lakhs may prove to be unviable when the cost raises to, say ₹ 150.00 lakhs due to cost-overrun. The problem of Cost-Overrun will get more compounded if the finance necessary to meet the increased cost can not be arranged in time. Any delay in arranging for the finance needed to meet the cost overrun will only further tend to increase the cost and this may land the project in trouble leading eventually to the death of the project and the project may not take off.

The following are some of the problem areas in implementation stage.

- The promoters may not be in a position to bring in funds to the required extent in time. In general, Banks/Financial institutions, of late, insist that the promoters shall bring in their capital contribution to the project upfront before release of loan. Any delay in bringing the stipulated capital by the promoters will delay the drawal of loan, which will lead to delay in implementation,
- The loan disbursement may be delayed if the promoters are not able to comply with major terms and conditions of the loan agreement, For example, the loan agreement, iwer-alia, may stipulate that collateral security to cover, say 25% of the loan amount shall be offered, The value of the property that the promoters offer as collateral security to the bank/financial institution may be short of the requirement. Or, when the value of the property meets the requirement, there may be other impediments like legal hurdles for clear, unencumbered title to the property etc.
- The cost of different components of project-cost may increase due to price escalation. The cost provided for some of the elements of project-cost might have been underestimated. It is also likely that some elements which are essential might have been left out. These factors lead to cost-overrun which may delay the project implementation,
- There may be delay in getting power connection, water connection, approval from local bodies, approval from pollution control authorities etc., which may postpone project implementation/commencement of production.
- When more than one institution are involved in funding a project, there may be delay in tying up the financial arrangements with the different institutions. This is more so when term loan and working capital loan are provided by two different institutions. The institution that is to lend working capital loan may wish to see that the project comes through successfully and reaches a ready-to-start stage before committing sanction of working capital finance. There is likelihood of the capital investment on the project having been fully made and the project waiting for sanction/release of working capital finance to commence commercial operations. Any delay in release of working capital finance due to procedural- formalities involved will harm the project heavily, as the capital investment will be lying idle, without earning any return.
- 'Rethinking' of the project during the course of implementation, like changes in production process, use of alternate raw material, changes in technology etc., may hold up project implementation.
- Over spending on travel, entertainment and non-productive assets like guest houses, compound walls, staff quarters etc., may result in cost-overrun, which in turn may delay project implementation.
- Adverse foreign currency exchange rate fluctuations may affect projects involving imported plant and machinery and may result in cost-overrun. This is an external factor over which the management has no control. However, a prudent management can guard against adverse foreign currency movement by entering into forward contracts etc.,

**Production:** The major aspects of production that may lead to sickness are

- Increase in the cost of product ion.
- Decrease in the quantity of production.
- Quality of product not meeting the standards/customer expectation.
- Producing more quantity than can be sold, leading to accumulation of stock.

The increase in cost of production may be due to external factors like increase in the cost of raw materials, increase in the cost of consumables, power, etc., or due to internal factors like improper choice of raw material/raw material-source, wrong choice of production process etc.

Decrease in quantity of production may be due to defects/under performance of plant and machinery, defects in production process etc.,

Defects in quality of products may be due to defects in raw material used, or due to unsatisfactory performance of machinery or due to ineffective supervision. In spite of the raw material, machinery and supervision being good, the advent of new technology may bring in product-obsolence and the product may lose customer preference.

Lack of proper planning of product mix and lack of co-ordination between production and marketing departments may lead to piling up of inventory, which will only add to the cost of the product.

## 9.6 PREVENTING CORPORATE FAILURES

It is a fact that some companies perform well and that some underperform and some fail. In many, if not most cases, these companies are led by executives that are quite experienced. Below are some recommendations that can help to reduce the risk of failures of organisations:

### 1. Appointment of non-executive directors

The non-executive directors will bring their special expertise and knowledge on strategies, innovative ideas and business planning of the organization. They will monitor the work of the executive management and will help to resolve situations where conflict of interest arises. Overall, the non-executive directors will act as a Cross Check.

### 2. Audit committees

Very often, there is occurrence of fraud in management and financial reporting. The presence of the audit committees will help to resolve this problem. Audit committees have the potential to reduce the occurrence of fraud by creating an environment where there is both discipline and control.

### 3. Development of environment learning mechanism

Some organizations fail because they lose touch with their environment. Therefore, to counter this problem, there is a need to develop the environmental learning mechanism. Through it, new information can be brought on continuous basis. This is mainly done by carrying customer-feedback surveys. In this way, the organisation can realign itself with the new needs and challenges.

### 4. Focus on research and development

Organizations can generate new knowledge by investing and focusing more on research and development. Thus, there will be more ideas how to make the products much better than that of their competitors.

It can be deduced that a director has a big responsibility that he has to assume these commendations mentioned above can help directors to reduce corporate failure, provided that the directors abide. Proper planning also is critical to the success of a business.

## 9.7 PREDICTION MODELS USED TO ASSESS CORPORATE FAILURE

### Introduction and Research Motive

Prediction of corporate bankruptcy is a phenomenon of increasing interest to investors/creditors, borrowing firms, and governments alike. Timely identification of firms' impending failure is indeed desirable. One major focus of Basel II regulations is also to minimize credit risk. Global economies have become cautious of risks involved in corporations' liabilities, especially after the demise of giant organizations like WorldCom and Enron.

It is vital to develop means and ways to identify potentially bankrupt firms. The models used to predict corporate bankruptcy are based on univariate analysis, multiple discriminant analysis (MDA), linear probability analysis, logit analysis, probit analysis, cumulative sums (CUSUM) methodology, partial adjustment process, recursively partitioned decision trees, case-based reasoning, neural networks, genetic algorithms, rough sets, entropy theory, gambler's ruin theory, cash management theory, credit risk theories, and some other techniques. These methods of corporate bankruptcy prediction have their own strengths and weaknesses and, hence, choosing a particular model may not be straightforward. This study aims at providing a onewindow shopping facility to potential users of bankruptcy prediction models. It presents a critical comparison of models' methodologies and their empirical applications with a view to improve future research in this area. To that end, this study divides corporate bankruptcy prediction models into three broad categories: statistical models, Artificially Intelligent Expert System (AIES) models, and theoretic models. Artificially Intelligent Expert System (AIES) models perform marginally better than statistical and theoretical models. Overall, use of Multiple Discriminant Analysis (MDA) dominates the research followed by logit models.

**(i) A Methodological Briefing on Corporate Bankruptcy Prediction Models**

To date attempts of corporate bankruptcy prediction have primarily used balance sheet information as likely symptoms of firm failure. Others have constructed models by looking at the causes of failure of corporations, the qualitative explanations of bankruptcy. Both strands of research have resulted into a number of prediction methods and models. In fact, almost all the models aim to predict corporate bankruptcy (the dependent variable) in a multivariate fashion. The only exceptions are the models constructed in the era before late 1960s, which did the job in a univariate manner.

This section briefly discusses methodologies of more commonly used prediction models, which are loosely classified into three broad categories: statistical models, artificially intelligent expert system models, and theoretic models. The first two categories look at the symptoms of failure, while the last considers causes of failure only.

**(A) Statistical Models**

The statistical models include univariate and multivariate analyses of which the latter dominates and uses multiple discriminant, linear probability, logit, and probit models.

**(a) Univariate Analysis**

Univariate analysis is a traditional method of interpreting financial statements using firms' financial ratios. These ratios serve as explanatory variables or the bankruptcy predictors, which are likely to exhibit significant differences across the failing and non-failing firms. The nature of analysis is, however, univariate in the sense that the variables are observed and examined one after the other. There is no allowance for an analysis capturing an integrated effect of any two or more variables together on financial health of the firm. After a careful analysis of these ratios, researchers would provide certain inferences about firms' financial health.

**(b) Multiple Discriminant Analysis (MDA)**

The discriminant analysis is a type of multivariate technique that allows to differentiate between two or more groups of objects with respect to several variables simultaneously. MDA is used to classify an observation (the firm here) into one of several a priori groupings (the bankrupt and non-bankrupt, in our case) dependent upon the observation's individual characteristics.

Under usual assumptions of regression analysis<sup>3</sup>, the MDA model is a linear combination of the discriminatory variables of the following form:

$$Z = \alpha + \beta_1 X_1 + \beta_2 X_2 + \dots + \beta_n X_n \dots \dots \dots [A]$$

where Z is a transformed value (score) of [A] used to classify the object,  $\alpha$  is a constant,  $\beta_s$  are discriminant coefficients, and  $X_s$  are values of independent discriminatory variables.



Due to the nature of Z that is actually a resultant score of linear combination of X variables in [A], estimates of discriminant coefficients are obtained following a specialized discriminant model estimation procedure. The classification typically involves defining some notion of distance between the case and each group centroids with the case being classified into the closest group. The results are, usually, presented in a classification matrix (also called accuracy matrix), which is often used to test the accuracy of the classification procedure too. The percentage of the known cases, which are correctly classified, is an additional measure of group differences. As a direct measure of predictive accuracy, this percentage is the most intuitive measure of discrimination and can be used to test the power of classification procedure.

As with any inferential technique based on sample data, the percent correct prediction overestimates the power of the classification procedure. A remedy is to use a hold out sample. One can validate the classification procedure by randomly splitting the sample into two subsets. One subset is used to derive the function and the other to test the classification.

**(c) Linear Probability Model (LPM)**

To fix the idea, let us start by considering the following model:

$$Y_i = \beta_1 + \beta_2 X_i + \mu_i \dots \dots \dots [B]$$

Where,

- $X_i$  : the explanatory variable (s)
- $Y_i = 1$  if the event occurs (say firm fails)
- $Y_i = 0$  if the event does not occur (say the firm does not fail)

Models like [B], which express the dichotomous  $Y_i$  as a linear function of the explanatory variable (s)  $X_i$ , are called LPM because the conditional expectation of  $Y_i$  given  $X_i$ , can be interpreted as the conditional probability that the event will occur given  $X_i$ ; that is,  $P ( Y_i = 1 | X_i )$ . Such a model can be estimated by using OLS technique, whereas variable  $Y_i$  follows a probability distribution in which probability must lie between 0 (when event does not occurs) and 1 (when event occurs). So, LPM models require that the conditional probability must lie between 0 and 1.

In application of LPM to bankruptcy prediction, a boundary value has to be found that will distinguish between those failing and non-failing firms in the population. Minimising the classification errors does this. LPM coefficients are used to construct performance scores for firms. Alternatively, the LPM scores may be interpreted as probabilities of failure.

**(d) Logit Model**

Under logit, the dichotomous dependent variable is simply the logarithm of the odds that a particular event (fail/non-fail) will occur. That is, here modelling of the 'log odds' of belonging to a group is pursued, rather than modelling the group membership itself.

Although it would be possible to model the odds, it is simpler to model the log (natural log, ln) of the odds [ $\ln(\text{odd}) = \ln ( P / 1-P )$ ]. This transformation into natural log, allows the dependent variable to take any value between negative infinity and positive infinity. In this way, the dependent variable becomes continuous too, rather than discrete. Now, [B] can be written in the logistic regression functional form as:

$$\ln ( P/1-P ) = \beta_1 + \beta_2 X_i + \mu_i \dots \dots \dots [C]$$

Hence, the probability that an event may occur, failure of firm in this case, is given

by:

$$P = \frac{1}{1 + e^{-(\beta_1 + \beta_2 X_i)}} \dots \dots \dots [D]$$



[D] is estimated using Maximum Likelihood method. Assuming that 0 indicates bankruptcy, the greater the resulting decimal fraction is above 0.5 (which implies an equal chance of a company being a failure or non-failure), the less chance there is of the subject firm going bankrupt

**(e) Probit Model**

In principal, one could substitute the normal cumulative distribution function in place of logistic into [D] and get the resulting probit model to be estimated by Maximum Likelihood method. Rest of the interpretations remain the same as in case of logit.

**(f) Cumulative Sums (CUSUM) Procedure**

CUSUM procedures are among the most powerful tools for detecting a shift from a good quality distribution to a bad quality distribution. They are a set of sequential procedures based on likelihood ratios for detecting a shift in a process. For many common distributions, the CUSUM procedure reduces to calculating cumulative sums, hence the name CUSUM.

A CUSUM model determines, in an optimal manner, the starting point of the shift and provides a signal of the firm's deteriorating state as early as possible soon after the shift occurs. A time series behaviour of the attribute variables for each of the failed and non-failed firm is described by a finite order VAR model. Based on sequential probability ratio tests and the theory of optimal stopping rules, the CUSUM model provides a signal of the firm's deteriorating condition.

According to the CUSUM model, the overall performance of a given point in time is assessed by the cumulative (dynamic) time-series performance score of a firm. For as long as the firm's annual (static) time-series performance scores are positive and greater than a specific sensitivity parameter, the CUSUM score is set to zero indicating no change in the firm's financial condition. Converse signals for the firm's changed condition.

**(g) Partial Adjustment Process**

Partial adjustment models are a theoretic rationale of famous Koyck approach to estimate distributed-lag models. Application of partial adjustment model in bankruptcy prediction can best be explained by using cash management behaviour of the firms as an example.

According to Laitinen and Laitinen (1998), cash management refers to the management of cash from the time it starts its transit to the firm until it leaves the firm in payments. Failure of the cash management can be defined as an imbalance between cash inflows and outflows. This leads to failure usually defined as the inability of the firm to pay its financial obligations as they mature.

Traditionally, cash management behaviour of a firm is described by different models of demand for money, e.g., the quantity theory of demand for money, which assumes that the demand for money does not differ from the demand for any funds in the firm. The most popular and simple approach to the demand for money in this framework is that followed by the inventory cash management approach, where demand for money by a firm is assumed to depend on the volume of transactions. The idea may be summarised as follows.

The actual cash balance of a firm in period *t* is a multiplicative function of *S* and *i* as follows:

$$\ln M(t) = \ln D + e_s \ln S(t) + e_i \ln i(t) + u(t) \dots\dots\dots [E]$$

Where;

*ln*: natural logarithm

*M(t)*: actual cash balance in period *t*

*D*: a scale constant

*S(t)*: the volume of transactions

*i(t)*: the opportunity cost

*e<sub>s</sub>*: the elasticity of cash balance with respect to *S*

$e_i$ : the elasticity of cash balance with respect to  $i$

$u(t)$ : a random error variable with standard autoregressive property

Equation [E] is static in nature whose dynamic version presented in partial adjustment form is as below:

$$\ln M(t) = y\{\ln D + e_s \ln S(t) + e_i \ln i(t) + u(t)\} + (1-y)M(t-1) + yu(t) \dots \dots \dots [F]$$

where  $y$  and  $(1-y)$  are the weights representing adjustment rate.

The overall classification and prediction process, in this particular example of partial adjustment model, follows the following criterion:

- For a failing firm, absolute values of the elasticities of cash balance with respect to the motive factors (volume of transactions and the opportunity cost here) will be smaller than for a similar healthy firm;
- For a failing firm, the rate of adjustment  $y$  may be even greater than unity and will certainly exceed the rate for healthy firm;
- Validity of the results can be tested by any appropriate technique like Lachenbruch procedure.

### **A Critical Analysis of Corporate Bankruptcy Prediction Models**

A critique to statistical models-

Univariate analysis of financial ratios was, initially, the approach followed by researchers like Beaver (1966). One critical assumption of this approach is that there exists a proportionate relationship between the variables in numerator and denominator of the ratio being calculated. However, as noted by Whittington (1980) and Keasey & Watson (1991), this assumption is very likely to violate on two grounds: (1) the relationship between the two variables may be non-linear resulting into non-proportionate outcome, (2) a constant term may also play some role in the relationship between two variables of the ratio under study, which will prevent proportionality to exist. Moreover, univariate analysis emphasises on individual signals of firms' impending distress and hence classification can take place for only one ratio at a time. As noted by Zavgren (1983) and Altman (1993), ratio analysis in such a univariate fashion is susceptible to faulty interpretation and is potentially confusing. Of course, financial status of a firm depends on multidimensional factors, and no single ratio may be capable to depict all these together.

Flawed with such limitations, univariate analysis was later replaced by multivariate analysis. Of these multivariate techniques, multiple discriminant analysis (MDA) has been on use quite extensively, starting from Altman (1968). MDA is neither a flawless model. It works on the assumptions that the group dispersion (variance-covariance) matrices are equal for failed and non-failed firms, and the population must be distributed in a multivariate fashion. Many studies, including Karles and Prakash (1987) have shown that these assumptions are often violated by the data set under study. Non-random sampling of distressed and non-distressed firms also creates biasness in results [Lin and Piesse (2001)]. In all, MDA works on very demanding assumptions, some of which are often violated in practice.

In search for a bankruptcy prediction model with lesser demanding assumptions, researchers suggested use of condition probability models like LPM, logit, and probit. LPM rests upon a number of assumptions that are usually not met. For example, error term is not normally distributed and is heteroskedastic. Further, it will generally produce lower measures of goodness of fit and there remains a possibility of value of dependent variable lying outside the 0-1 ranges [Gujarati (1998)].

Problems, with which LPM is beset by, can be overcome by selecting a probability function that follows cumulative distribution like that of logit or probit. Many have preferred to use logistic over probit merely for practical ease. Both logit and probit perform best when the sample size is large. Unfortunately, number of bankrupt firms is usually not large enough to make these models an optimum choice. Small sample size usually restricts use of logit or probit models in practice [Stone and Rasp (1991)]. Their results are also affected when the number of predictors is very large and the variables are continuous [Morris (1998)]. Moreover, Logit and probit models are comparatively difficult in computational terms than MDA.

There have been some attempts to employ time series framework under CUSUM and partial adjustment models. The major problem faced by these models is to employ a reasonable length of time series. These models might be subject to econometric limitations like very short length of available time series in case of bankruptcy data. Additionally, these have failed to get an encouraging response from academicians and practitioners so far.

### **(B) Artificially Intelligent Expert System (AIES) Models**

Initially considered numeric machines, it was later realized that computers can also process symbols to exhibit the intelligent behaviour of humans' cognitive activities like problem solving. This realization triggered a search for programs that could emulate human cognitive skills in an acceptable way. Hence, a body of knowledge dealing with designing and implementation of such programs started to emerge since 1950s. Since this 'intelligence' of computers is contained in machines, and not in human brains, their exhibited behaviour is known as 'Artificial Intelligence' (AI).

Humans use their intelligence to solve problems by applying reasoning based on the knowledge possessed in their brains. Hence, knowledge plays the pivotal role in human intelligence. AI, in order to be as competitive as human intelligence or at least comparable, should benefit from similar knowledge in application of its reasoning to the problem posed. Expert systems (ES) were developed to serve this purpose for AI.

An ES initiates from the process of transferring knowledge, which is considered to be 'the bottleneck problem' of ES. Two automation processes have dominated research in the field of knowledge acquisition: 'machine teaching' and 'machine learning', of which latter has assumed more significance than former.

'Learning' may be considered as a system capable of improving its performance on a problem as a function of previous experience. A machine may learn under strict or no supervision, yet moderate supervision is observed more in practice.

Subsequent research resulted into a variety of supervised machine learning methods, which proved quite successful in solving problems for different domains, including bankruptcy prediction. Following discussion provides a basic understanding of most commonly used techniques and their application in bankruptcy prediction.

#### **(a) Recursively Partitioned Decision Trees (Inductive learning Model)**

One form of supervised learning is inductive learning. An inductive learning program is able to learn from examples by a process of generalization. Many human experts also learn in this way. Decision trees are one way of inductive learning. A decision tree partitions a training data set into sub-classes. Procedure then proceeds to recursively replace each of the subset with a decision tree, resulting into a final decision tree for the initial training set.

Friedman (1977) first introduced recursive partitioning decision rule for nonparametric classification. As suggested by Pompe and Feelders (1997), 'the basic idea of recursive partitioning is to fit a tree to the training sample by successively splitting it into increasingly homogeneous subsets until the leaf nodes contain only cases from a single class or some other reasonable stopping criterion applies'.

In bankruptcy classification, the decision tree is constructed by recursively partitioning the training sample until the final nodes of tree contain firms of only one type: bankrupt or healthy. Any new object (firm) is then classified according to the place of final node it falls in the tree. This node identifies the firm's group membership and associated probability.

#### **(b) Case-Based Reasoning (CBR) Model**

Like human experts, CBR solves a new classification problem with the help of previously solved cases in the same domain of knowledge. A case, in the context of CBR, would consist of a contextual knowledge that represented an experience. Usually, a CBR process of knowledge acquisition would pass through four stages: (1) identification, acceptance and representation of a new problem, (2) retrieval of old



similar cases from the case library, (3) adapting the cases retrieved in step 2 in a way that they fit to the new situation and provide an appropriate solution to it, and (4) evaluation of the suggested solution and finally storing the evaluated solution in the case library for future use.

In the context of corporate bankruptcy prediction, a CBR program would first develop a case library of previously solved prediction problems. It would, then identify, accept, and represent any new prediction problem. Next, it would adapt a similar case retrieved from the case library to appropriately fit the new problem and provide prediction result. Before storing this solution in the case library, a CBR program would also evaluate the suggested prediction result.

### **(c) Neural Networks (NN)**

Although capable of outperforming human brain in basic arithmetic calculations, computers are certainly inferior when it comes to tasks involving symbolic recognition like signs of bankruptcy in a firm. Neural networks are enthused by biological works related to brain and its nervous system to triumph over this lack of computational efficiency in computers. Neural networks perform the classification task, in response to impending signals of financial health of a firm, in the way a brain would do for example in deciding whether the food is salty or sweet by its taste signal.

Human brain is made up of certain types of neurons (nerve cells), which is the base of neuroscience. Neurons, in neural networks, are called 'processing elements' or 'nodes'. Like real neurons, these nodes are connected to each other through 'weighted interconnections' (synapses in neuroscience terms). Nodes are organized in layers. Each node takes delivery of, joins, and converts input signals into a single output signal via weighted interconnections. This output signal is accepted as the classifying decision if it satisfies the researcher; otherwise it is transmitted again as an input signal to many other nodes (possibly including itself). Process keeps going until satisfaction is gained from researchers' point of view.

Perhaps the major task of any neural network is to determine appropriate weights to interconnections of different nodes. Neural networks perform this task by a training process in which knowledge about the relationship between input and output signals is learned following certain principle. This knowledge produces a distinct structure of nodes (in one of the network layers called 'hidden layer') and connection weights, which correctly classifies the objects into their respective known groups.

Technically, this process of mapping is termed as 'convergence'. Following a mathematical theorem, the network is always able to converge.

While predicting corporate bankruptcy, NN would take information on explanatory variables at input nodes via input layer. The hidden layer nodes, connected to input nodes through weighted interconnections, collect and process this information to suggest a probability of a firm getting failed or succeeded.

### **(d) Genetic Algorithms (GA)**

Based on the idea of genetic inheritance and Darwinian theory of natural evolution (survival of the fittest), GAs work as a stochastic search technique. GAs perform their search for optimal solution to the problem posed from a large and complicated space of solutions.

GAs are usually explained with the help of vocabulary, inevitably, borrowed from natural genetics. Each individual potential candidate solution to the problem is represented by a 'string' (also called 'chromosome', 'genotype' or 'structure'). These 'strings' are made of 'units' (also called 'genes', 'features', 'characters', or 'decoders'). Under GAs, an evolution process is run on a population of 'strings' that corresponds to a search through a space of potential solutions.

GAs execute this search process in three phases: genetic representation & initialisation, selection, and genetic operation (crossover and mutation). Genetic representation that is normally in binary alphabet (0 and 1) creates an initial population of solutions. After the initialisation, each string is evaluated with the help of a user-defined fitness function. Over time, such a selection process is likely to result into

best performing strings only. Straightforward reproduction of selected strings entails no benefit in terms of exploration of solution space, as this will only reproduce the identical offspring from the parent strings. Genetic operations of Crossover and Mutation are introduced for this purpose. The process continues until the actual population converges towards increasingly homogeneous strings. In general, the process is stopped when we are satisfied with a certain level of homogeneity.

In order to solve a classification problem like bankruptcy, researchers extract a set of rules or conditions using GAs. These conditions are associated with certain cut off points. Based on these conditions, the model would predict whether or not a firm is likely to go bankrupt.

### **(e) Rough Sets Models**

The central quandary of rough sets theory is classification. Theory aims at complete classification of objects to a specified category with the help of information on these objects that is factually inadequate. Hence, this indiscernible or imprecise information about the objects to be classified, is the mathematical basis of rough sets theory. A set of all indiscernible objects is labelled 'elementary set', which is the universe of objects. A set of objects consisting of elements that are union of some elementary sets is called crisp (or precise). Otherwise the set is known as rough (or imprecise) set.

In a rough set model, inadequate knowledge about the objects is presented in the form of an information table. Rows, columns, and entries of the table are respectively called 'objects', 'attributes', and 'attribute values'. This information table can also be considered a decision table containing sets of condition and decision attributes. The decision table is used to derive the decision rules of the model. These rules are derived on the basis of inductive learning principles and are the end result of rough sets model. Every new object is classified by matching their characteristics with the set of derived rules.

In its application to the case of corporate bankruptcy prediction, a rough set model collects and presents the available information on firms to be classified as bankrupt or healthy in an information table. Following inductive learning principle, the model generates a set of rules that help determine the actual group membership of the firms.

### **A Critical Analysis of Corporate Bankruptcy Prediction Models**

A critique to AIES models-

Artificially Intelligent Expert System (AIES) models are also subject to certain limitations. For example, Inductive Learning model (recursively partitioned decision trees) is a forward selection method that is liable to reconsidering a currently analysed variable at some later stage too. It is also exposed to the problem of over fitting [Dimitras et al. (1996)].

Some AIES models, like case based reasoning (CBR), are still at the stage of infancy in their life. Such models require a lot of improvements. For example, CBR lacks a convincing methodology of interviewing human experts and collecting cases. Index selection in CBR is still a problem to be addressed. Solutions provided by the CBR are built-in with the help of previously solved problems. However, deriving truly creative solutions requires studying further the process of brainstorming in human experts. Optimal size of cases to be represented, accommodating continues case situations, and their connectivity also counts towards CBR limitations [Kolodner (1993)].

Despite a number of studies advocating usefulness of Neural Networks (NN), there are flaws in these models too. As noted by Shin and Lee (2002), finding an appropriate NN model to reflect problem characteristics is not an easy job. It is because there are a number of network topologies, learning methods and parameters. Most importantly, NNs are characterized as 'black boxes' due to inability of the users to readily comprehend the final rules acquired by NNs to solve the problem.

Additionally, Altman and Varetto (1994) note that long processing time to complete the NN training stage, requirement of having a large number of tests to identify appropriate NN structure, and the problem of over fitting can considerably limit the use of NNs.

Genetic Algorithm (GA) models are also in the process of development. Major problem of GAs,

identified by Shapiro (2002), is that they are difficult to tune and have no convergence criteria. Another important shortcoming of GAs is that there is no pre-defined way of including constraints into GAs [Aickelin and Dowsland (2003)]. This particular problem does not make GAs readily amenable to most real world optimisation problems.

Finally, Rough set models don't perform well with numeric data set. Theory requires conversion of numeric data into non-numeric form before it can be used [Mak and Munakata (2002)]. Basic disadvantages of rough sets, as noted by Yasdi (1995), are: high noise sensitivity, multimodality, and lack of performance-oriented fitting to task requirements.

### **(c) Theoretic Models**

Focus of statistical and AIES models is on firms' symptoms of failure, rather than causes. These models are able to predict bankruptcy by looking at distress conditions present in the firms. However, another way of approaching this problem is to look at the factors that force corporations to go bankrupt. Under this approach, prediction models are constructed based on some theoretic arguments. Quite a few attempts have been made in this respect and are briefly described in this section.

#### **(a) Balance Sheet Decomposition Measure (BSDM) / Entropy Theory**

One way of identifying firms' financial distress could be a careful look at the changes occurring in their balance sheets. Following this procedure, the argument would tag along this guideline: "like any enterprise, firms would tend to maintain a state of equilibrium that ensures sustaining existing firms' structure". If a firm's financial statements reflect significant changes in their balance sheet composition of assets and liabilities over a reasonable period of time, it is more likely that the firms are incapable of maintaining the equilibrium state. Since these changes are likely to become uncontrollable in future, one can foresee financial distress in these firms. This economic rationale of firms' likely failure is the argument of BSDM or entropy theory.

#### **(b) Gambler's Ruin Theory**

The basic idea of this theory relates with the game of a gambler, who plays with an arbitrary sum of money. Gambler would play with some probabilities of gain and loss. Game would continue until the gambler loses all his money. Theory would also talk about gambler's ultimate ruin and expected duration of the game.

In context of the firm's failure, firm would take the place of a gambler. Firm would continue to operate until its net worth goes to zero, point where it would go bankrupt. The theory assumes that firm has got some given amount of capital in cash, which would keep entering or exiting the firm on random basis depending on firm's operations. In any given period, the firm would experience either positive or negative cash flow. Over a run of periods, there is one possible composite probability that cash flow will be always negative. Such a situation would lead the firm to declare bankruptcy, as it has gone out of cash. Hence, under this approach, the firm remains solvent as long as its net worth is greater than zero. This net worth is calculated from the liquidation value of stockholders' equity.

#### **(c) Cash Management Theory**

Short-term management of corporate cash balances is a major concern of every firm. Cash or funds flow statements of the firms report this cash management function of corporations, particularly from 1980s. An imbalance between cash inflows and outflows would mean failure of cash management function of the firm. Persistence of such an imbalance may cause financial distress to the firm and, hence, bankruptcy.

#### **(d) Credit Risk Theories**

Credit risk theories, closely related to Basel I and Basel II accords, mostly refer to the financial firm. The proposed Basel II framework consists of three pillars: (1) minimum capital requirements, currently set equal to 8%, according to a purposely-defined capital ratio, (2) supervisory review of an institution's internal assessment process and capital adequacy, (3) effective use of public disclosure to strengthen market discipline as a complement to supervisory efforts.

The current Basel II Accord utilises concept of a capital ratio that is calculated dividing bank's capital amount by a measure of risk faced by it (referred to riskweighted assets). There is a wide variety of risks faced by banks and other financial institutions these days including credit risk, market risk, operational risk, investment risk, interest rate risk, exchange rate risk, concentration risk and country transfer risk. Basel II focuses mainly on the first three of these with a view that other risks are implicitly covered. Basel II framework adequately treats both market risk (that results due to trading activities) and the operational risk (defined as the risk of losses due to inadequate or failed internal processes, people and systems, or external events). However, the Accord clearly recognises that, for most banks, it is the credit risk that matters more. Focus of our study is also limited to credit risk only, for it is related to counterparty failure (the borrowing firm).

As noted by Westgaard and Wijst (2001), credit risk is the risk that a borrower/ counterparty will default, i.e., fail to repay an amount owed to the bank. Credit risk includes all of the counterparties and reasons for which they may default on their obligations to repay. Following Basel II guidelines, in the last few years, a number of attempts have been made to develop internal assessment models to measure credit risk. A few of them have gained more respect than others including JP Morgan's Credit Metrics, Moody's KMV model, CSFP's CreditRisk+ and McKinsey's Credit Portfolio View. More importantly, with one or two exceptions, these models and risk predictions thereof have been based on either microeconomic or macroeconomic theories of corporate finance. Collectively these models may be referred as credit risk theories.

The most famous microeconomic theory is related to the theory of option pricing as suggested by Black and Scholes (1973) and later developed by Merton (1974). An option is a security that gives the holder a right to execute a transaction (to buy or sell an asset) in future at a price determined today. Options are of two types: a call option gives the right to buy, whereas the put option means the right to sell. Options are used in many instances including speculation, hedging a borrowing, capital preservation, covered call etc. A simple example is a call option on a common stock, in which the payout on the call is determined solely by the value of the stock. Excess of stock price over the strike price determines the payout to holder who will exercise the call. In the opposite case, payout will be zero and the holder will not exercise his right. Right pricing or valuation of the options is important. Black and Scholes presented a complete general equilibrium theory of option pricing that constructed a valuation formula, which is based on observable variables. Both Black & Scholes and Merton recognize that their approach could be applied in developing a pricing theory for corporate liabilities in general. They determine the option value as the solution of a partial differential equation to which the price of any option must conform, subject to boundary conditions given by the form of the payout. Under this asset value option pricing approach, firms' default process is endogenously related to its capital structure. Firm would default on its obligations to the bank, if the value of its assets falls below certain critical level determined by the respective credit risk model. Option pricing theory is also the base of JP Morgan's CreditMetrics and Moody's KMV models. An example of macroeconomic theory is the one that relates to credit portfolio risk measurement that was introduced by Wilson (1997a, 1997b, 1998). The theory states that credit cycles follow business cycles closely, i.e., a worsening economy would be followed by downgrades and defaults increase. Here default probability of a firm is a function of macroeconomic variables like unemployment rate, interest rates, growth rate, government expenses, foreign exchange rates, and aggregate savings etc. This theory also serves as the base for McKinsey's Credit Portfolio View model.

### **A Critical Analysis of Corporate Bankruptcy Prediction Models**

A critique to theoretic models-

Both statistical and AIES models were built without any theoretical base. Predicting corporate bankruptcy using a model without a theoretic support has long been questioned. Researchers have, therefore, tried to explain the failure process of firms with the help of some theories as discussed in previous section. This section presents a brief discussion on limitations of such theories and models constructed thereof.

Balance Sheet Decomposition Measure (BSDM) or entropy theory is characterized with a major flaw in



it: it focuses only on the change in balance sheet structure not caring for the direction of this change. This fact limits the theory to distinguish between a firm whose balance sheet changes are not due to failure but due to growth. Booth and Hutchinson (1989) have also found this limitation in an empirical work. Moreover, some researchers, including Moyer (1977), concluded from their studies that BSDM is not a useful predictor of bankruptcy.

The simplest version of gambler's ruin model assumes that firm has no access to external capital in order to finance its losses. However, as noted by Scott (1981), attempts to apply this model have been disappointing. Obviously, firms do have at least an imperfect access to external capital market as suggested by Scott (1981). Although model suggested by Scott overcomes the flaw present in simple gambler's ruin model, no one has attempted to use this method in practice.

Cash management theories do provide a reasonable explanation of firm failure, yet this is not the only cause of distress. Many other significant predictors may still remain un-captured, if only cash flow variables are assumed to be significant. Particularly, firm's stock and equity may have some important role to play as suggested by credit risk theories.

Study discusses four models representing credit risk theories. KMV has strongly criticised the use of transition probabilities by Credit Metrics, which is based on average historical frequencies of defaults and credit migration. As observed by Crouhy et al. (2000), KMV objects on the two critical assumptions of Credit Metrics: (1) all firms within the same rating class have the same default rate, and (2) actual default rate is equal to the historical average default rate. KMV considers this cannot be true since default rates are continuous, while ratings are adjusted in discrete manner. KMV has proved, through a simulation exercise, that the historical average default rate and transition probabilities can deviate significantly from the actual rates. Moreover, Derviz and Kadlcakova (2001) observe that assumption of default free deterministic interest rates makes the model insensitive to market risk and underlying changes in economic environment. They also note that the model proxies asset returns correlations by equity return correlations, and this might lead to an imprecise estimation.

On the other hand, KMV model is considered to be a too capital simplistic structure of the firm, as noted by Derviz and Kadlcakova (2001). They also consider that the assumption of high diversification may not necessarily meet in real world, and this may misrepresent the need of economic capital. Finally, they note that the relationship between Distance to Default and EDF is based on US data, and their derivation is not thoroughly explained. Therefore, straightforward implementation of the model, outside USA, might be questionable. Crouhy et al. (2000) observe that KMV assumes no market risk and fails to deal with non-linear products like foreign currency swaps.

Major drawbacks of CreditRisk, as observed by Crouhy et al. (2000), are assumption of no market risk and inability to deal with non-linear products. Derviz and Kadlcakova (2001) state another limitation of the model that relates to the specification of default rates for individual obligors. Specification of these default rates is quite ambiguous, despite the fact they enter the model as basic input.

Crouhy (2001) consider that Credit Portfolio View model necessitates reliable default data for each country, and possibly for each industry sector within each country. This is, obviously, not an easy job to do. They also criticise the ad-hoc procedure to adjust the migration matrix. Derviz and Kadlcakova (2001) view the dependence of default on macroeconomic factors, as an assumption too strong. After all, microeconomic factors do play a role in default and credit quality migration too.

## **(ii) Applications of Corporate Bankruptcy Prediction Models**

To undertake the empirical exercise, study benefits from a total of 46 major applications of prediction models to the case of corporate bankruptcies (43 journal articles, 1 technical report, 1 discussion paper, and 1 departmental document). Table 1 reports almost all the critical information from these studies. It refers to the models used in previous research, which happen to be 89 in 46 studies. Table reports only best predictive accuracy rates of the models, one year before failure, to keep the analysis consistent and simple. The abbreviations used in Table 1 are explained in Appendix given in the end.



A careful look at the attributes presented in Table 1 reveals quite interesting results. For example, a large number of journals seem interested in this area of research. However, 'Journal of Business Finance and Accounting' takes a lead by publishing roughly 16 % of analysed papers. 'European Journal of Operational Research' stands second by publishing 8% of the studies. 'Financial Management' and 'Expert Systems with Applications' follow next. Future research may take this finding as a loose index to locate the journals in this area of research.

Predictive results of any empirical work value more in the presence of a holdout sample. However, only 46% of the total studies used a holdout or test sample of firms to verify their predictive claims. Such a weakness in past research warns future research in this area to recognize the importance of holdout sample.

Problem of small sample size has always been a predestined limitation of application of these models to the case of corporate bankruptcy prediction. Table 1 confirms this too. Although the estimation sample size in these studies ranges from 32 to 35287 numbers of firms, about 42% studies worked with a sample of only less than 100 firms. This inevitable constraint suggests that future research may not be criticised much on this particular account.

Conventionally, bankruptcy prediction studies have used financial ratios to predict failure in firms. This fact is also evident from Table 1, where more than 60% studies use only financial ratios as explanatory variables. About 7% studies work with cash flow information. Remaining studies employ a mix of financial ratios and other variables. These studies happen to use a wide range of financial ratios including the ones measuring liquidity, solvency, leverage, profitability, asset composition, firm size, growth etc. Other variables of interest include information on macroeconomic, industry specific, location or spatial, and firm specific variables. These findings reemphasize the importance of information on company accounts. However, we would suggest using a mix of variables possibly in proportion to their use in past studies.

Bankruptcy being more common in public firms and relatively easy access to the required data, almost all the studies work on data sets of public limited companies. Further, most researchers tend to work on a sample of mix industry firms. Around 43% studies construct their empirical analysis on the data of mix industries. Manufacturing sector ranks second with 25% share, which includes occasional enclosure of retail or mining industry. Limitation of small sample size and finding of the study in favour of mix industry, it may prove useful for future research to work with mix industry sample.

### 9.8 THE MODELS TO PREDICT CORPORATE FAILURE

Several techniques have been developed to help predict why companies fail. However, these are not accurate and do not guarantee that the prediction will turn out to be true. These models are The Z-Score, Argenti Model, and the VK model amongst others.

Beaver was one of the first researchers to study the prediction of bankruptcy using financial statement data. The established practice for failure prediction is therefore a model based on financial ratio analysis. Published financial reports contain a great deal of information about the company performance and prospects. Therefore, ratio analysis is not preferred for financial accounts interpretation however; it has also played a central role in the development of bankruptcy prediction models.

#### (i) The Altman Model: Z-Score

The Z-Score model is a quantitative model developed by Edward Altman in 1968, to predict bankruptcy or financial distress of a business. The Z-score is a multi variate formula that measures the financial health of a company and predicts the probability of bankruptcy within 2years. This model involves the use of a specified set of financial ratios and a statistical method known as a Multiple Discriminant Analysis. (MDA). The real world application of the Altman score successfully predicted 72% of bankruptcies two years prior to their failure.



The model of Altman is based on a linear analysis in which five measures are objectively weighted and summed to arrive at an overall score that then becomes the basis for classification of companies into one of the two a priori groupings that is bankrupt or non-bankrupt. These five indicators were then used to derive a Z-Score. These ratios can be obtained from corporations' financial statements.

**The Five Z-Score Constituent Ratios are:**

1. Working Capital/Total Assets (WC/TA):- a firm with negative working capital is likely to experience problems meeting its short-term obligations.
2. Retained Earnings/Total Assets: - Companies with this ratio high probably have a history of profitability and the ability to stand up to a bad year of losses.
3. Earnings Before Interest & Tax/ Total Assets: - An effective way of assessing a firm's ability to profit from its assets before things like interest and tax are deducted.
4. Market Value of Equity/ Total Liabilities: - A ratio that shows, if a firm were to become insolvent, how much the company's market value would decline before liabilities exceed assets.
5. Sales/Total Assets: - A measure of how management handles competition and how efficiently the firm uses assets to generate sales.

Based on the Multiple Discriminant Analysis, the general model can be described in the following form:

$$Z=1.2WC/TA + 1.4 RE/TE + 3.3 EBIT/TA + 0.6 MVE/TL + 1.0 SL/TA$$

**Probability of Failure According to the Z-Score Result:**

Z-Score	Probability of Failure
Less than 1.8	very High
Greater than 1.81 but less than 2.99	Not Sure
Greater than 3.0	Unlikely

Calculation of the Z-Score for a fictitious company where the different values are given to calculate the Z-Score.

Sales	25,678
Total Assets	49,579
Total liabilities	5,044
Retained earnings	177
Working Capital	-1,777
Earnings before interest and tax	2,605
Market value of Equity	10,098
Book value of Total Liabilities	5,044

**The Calculations of the Ratios are as follows:**

1. Working Capital/Total Assets  $(-1,777/ 49579) = -0.036$
2. Retained Earnings/Total Assets  $(177/ 49579) =0.004$
3. Earnings Before Interest & Tax/ Total Assets  $(2605/ 49579)= 0.053$
4. Market Value of Equity/ Total Liabilities  $(10098/ 5044)= 2.00$
5. Sales/Total Assets  $(25978/ 49579)=0.52$

Thus according to the formula the answer should be:

$$Z=1.2(-0.036) + 1.4 (0.004) + 3.3 (0.053) + 0.6 (2.0) + 1.0(0.52)$$

$$Z= -0.04+ 0.01+0.17+1.20+0.52$$

$$Z=1.86$$

According to Altman, this company may or may not fail as it is greater than 1.81 but less than 2.99, which situates it neither on the safe side nor on the failure side.

**(ii) Argenti Model**

Another model for predicting corporate failure is the Argenti Model. Argenti's Model is perhaps the most distinguished from other models. J. Argenti developed a model which is intended to predict the likelihood of company failure. In his classification, Argenti (1976) distinguished 3 types of failure namely Type 1, Type 2 and Type 3 failures. A Type 1 failure characterises the failure of newly formed and therefore mainly small companies. Whereas, Type 2 is characterised by the presence of a very ambitious, charismatic and active manager with an outstanding personality. Due to his over ambition the company is brought down. These failure types can occur to young organisations, but they usually survive longer than Type 1 companies. Type 3 failures only occur to mature companies that have been operating successfully over a fair number of years and that often are of a major social and economic importance to the community. The largest characteristic of Type 3 companies is its insensitivity towards changes in the environment, whereas the world around it is changing with its environment.

**(iii) Dr. L.C. Gupta's Sickness Prediction Model**

Dr. L.C. Gupta made an attempt to distinguish between sick and non-sick companies on the basis of financial ratios. He used a simple non-parametric test for measuring the relative predicting power of different financial ratios. A mixed sample of sick and non-sick companies was made and the companies in the sample were arranged in a single ordered sequence from the smallest to the largest, according to the financial ratio that is tested for its predictive power. Let  $[\text{profit after tax} \div \text{Net worth}]$  is a financial ratio that is to be tested for its predictive power. The companies in the sample are arranged in increasing order of this particular ratio. Let the sick companies be denoted by the letter 'S' and the non-sick ones by the letter 'N'. Let us assume that 8 sick companies and 8 non-sick companies are taken for building up the sample. When arranged in a sequential order as stated above, the sequence may result in any pattern as shown below:

- (A) S-N-S-N-S-S-N-S-N-N-S-N-S-N-S-N
- (B) S-S-S-S-S-S-S-N-N-N-N-N-N-N-N
- (C) S-S-S-S-N-N-N-N-N-N-N-N-S-S-S-S
- (D) S-S-S-N-S-S-N-N-S-S-N-N-S-N-N-N

Observing the pattern of occurrence of 'S' and 'N' a cut off point is chosen to separate the sick group from the non-sick group. Companies that fall to the left of the cut off point lie in the sick group while companies that fall to the right of the cut off point lie in the non-sick group. The cut off point is so chosen that the number of misclassifications are minimised. The ratio that showed the least percentage classification error at the earliest possible time is deemed to have the highest predictive power. Referring to the four patterns shown above, the pattern of sequence shown in (B) is the most accurate one since the cut off point will be located exactly midway in the sample group and the percentage of classification error will be zero since there are no misclassifications. Pattern shown in (C) is bound to have a higher error since the sick companies are concentrated on both the extreme ends.

Dr. L.C. Gupta used Indian data on a sample of 41 textile companies of which 20 were sick companies and 21 were non-sick companies. He studied the predictive power of 63 financial ratios and observed that the following two ratios have comparatively better predictive power.

(a)  $(\text{Earnings before Interest and Taxes}) \div \text{Sales}$

and

(b)  $(\text{Operating cash flow}) \div \text{Sales}$

[Note :  $\text{Operating cash flow} = \text{profit after tax} + \text{depreciation}$ ]

## 9.9 PERFORMANCE IMPROVEMENT STRATEGIES

The key to preventing corporate failure is to spot the warning signs early, and take corrective action quickly.

- The actions needed will depend on the particular situation. Once the signs of impending failure are seen, it is important to investigate and identify the causes.
- These may be related to a range of different functions within the business, such as financial management, marketing or production.
- It may sometimes be necessary to seek external advice to help to identify the problem.
- It is important that the managers of the business accept that there is a problem and that mistakes have been made and to move on to a solution, rather than apportioning blame.
- Actions may involve major strategic change, such as getting out of a loss-making business, or making changes to the way operations are managed, such as changes to production management.
- The action needed may include putting in controls to prevent further loss.
- The best strategy to prevent failure is to have effective management systems in place to begin with.

The performance management system will need to reflect the performance improvement strategies:

- a link should be established between the new strategic goals and CSFs
- performance targets should be set at all levels and these should relate to the achievement of strategic objectives
- continuous review of actual performance against targets will be required
- additional training and development needs must be met.

### Long-term survival and the product life cycle

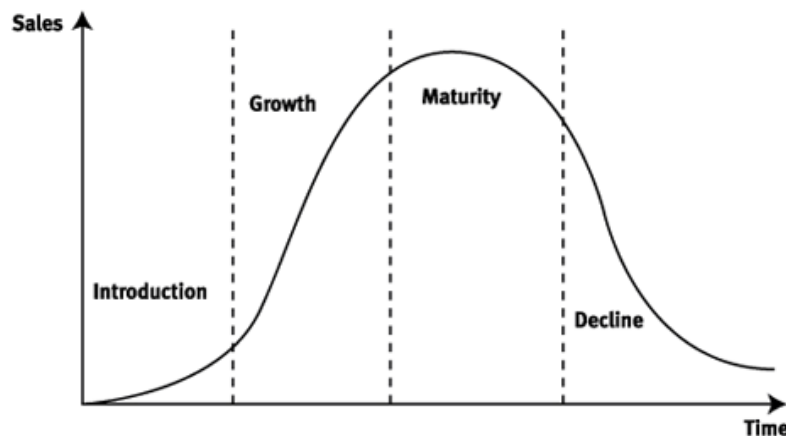

### The 'classic' product life cycle

The 'classic' life cycle for a product has four phases, with different CSFs.

- An introduction phase, when the product or service is first developed and introduced to the market. Sales demand is low whilst potential customers learn about the item. There is a learning process for both customers and the producer, and the producer might have to vary the features of the product or service, in order to meet customer requirements more successfully.

- A growth phase, when the product or service becomes established and there is a large growth in sales demand. The number of competitors in the market also increases, but customers are willing to pay reasonably high prices. The product becomes profitable. Variety in the product or service increases, and customers are much more conscious of quality issues.
- A maturity phase, which might be the longest stage in the product life cycle. Demand stabilises, and producers compete on price.
- A decline phase, during which sales demand falls. Prices are reduced to sustain demand and to slow the decline in sales volume. Eventually the product becomes unprofitable, and producers stop making it.

**Long-term survival necessitates consideration of life-cycle issues:**

**Issue 1:** There will be different CSFs at different stages of the life cycle. In order to ensure that performance is managed effectively KPIs will need to vary over different stages of the lifecycle.

**Issue 2:** The stages of the life cycle have different intrinsic levels of risk:

- The introduction period is clearly a time of high business risk as it is quite possible that the product will fail.
- The risk is still quite high during the growth phase because the ultimate size of the industry is still unknown and the level of market share that can be gained and retained is also uncertain.
- During the maturity phase the risk decreases and the final phase should be regarded as low risk because the organisation knows that the product is in decline and its strategy should be tailored accordingly.

Understanding and responding to these risks is vital for the future success of the organisation.

If there is an analysis of the developing risk profile it should be compared with the financial risk profiles of various strategic options, making it much easier to select appropriate combinations and to highlight unacceptably high or low total risk combinations. This for an organisation to decide to finance itself with debt during the development stage would represent a high total risk combination.

9.10 Improvement, Identification and procedure of operational changes to performance management system in performance improvement strategies.

**9.9.2 Performance-Definition**

Performance is a measure of the results achieved. Performance efficiency is the ratio between effort expended and results achieved. The difference between current performance and the theoretical performance limit is the performance improvement zone.

Another way to think of performance improvement is to see it as improvement in four potential areas. First, is the resource INPUT requirements (e.g., reduced working capital, material, replacement/reorder time, and set-up requirements). Second, is the THROUGHPUT requirements, often viewed as process efficiency; this is measured in terms of time, waste, and resource utilization. Third, OUTPUT requirements, often viewed from a cost/price, quality, functionality perspective. Fourth, OUTCOME requirements, did it end up making a difference.

Performance is an abstract concept and must be represented by concrete, measurable phenomena or events to be measured. Baseball athlete performance is abstract covering many different types of activities. Batting average is a concrete measure of a particular performance attribute for a particular game role, batting, for the game of baseball.

Performance assumes an actor of some kind but the actor could be an individual person or a group of people acting in concert. The performance platform is the infrastructure or devices used in the performance act.



There are two main ways to improve performance: improving the measured attribute by using the performance platform more effectively, or by improving the measured attribute by modifying the performance platform, which in turn allows a given level of use to be more effective in producing the desired output.

For instance, in several sports such as tennis and golf, there have been technological improvements in the apparatuses used in these sports. The improved apparatus in turn allows players to achieve better performance with no improvement in skill by purchasing new equipment. The apparatus, the golf club and golf ball or the tennis racket, provide the player with a higher theoretical performance limit.

Performance improvement is the concept of measuring the output of a particular process or procedure, then modifying the process or procedure to increase the output, increase efficiency, or increase the effectiveness of the process or procedure. The concept of performance improvement can be applied to either individual performance such as an athlete or organizational performance such as a racing team or a commercial enterprise.

In Organizational development, performance improvement is the concept of organizational change in which the managers and governing body of an organization put into place and manage a program which measures the current level of performance of the organization and then generates ideas for modifying organizational behavior and infrastructure which are put into place to achieve higher output. The primary goals of organizational improvement are to increase organizational effectiveness and efficiency to improve the ability of the organization to deliver goods and or services. A third area sometimes targeted for improvement is organizational efficacy, which involves the process of setting organizational goals and objectives.

Performance improvement at the operational or individual employee level usually involves processes such as statistical quality control. At the organizational level, performance improvement usually involves softer forms of measurement such as customer satisfaction surveys which are used to obtain qualitative information about performance from the viewpoint of customers. A simple but comprehensive guide to Performance Improvement has been developed by the United States Coast Guard. This guide illustrates many of the tools that are available for your use in Performance Improvement.

### **9.9.3 Business Process Improvement**

Business process improvement (BPI) is a systematic approach to help an organization optimize its underlying processes to achieve more efficient results. The methodology was first documented in H. James Harrington's 1991 book Business Process Improvement. It is the methodology that both Process Redesign and Business Process Reengineering are based upon. BPI has been responsible for reducing cost and cycle time by as much as 90% while improving quality by over 60%.

Process improvement is an aspect of organizational development (OD) in which a series of actions are taken by a process owner to identify, analyze and improve existing business processes within an organization to meet new goals and objectives, such as increasing profits and performance, reducing costs and accelerating schedules. These actions often follow a specific methodology or strategy to encourage and ultimately create successful results. Process improvement may include the restructuring of company training programs to increase their effectiveness.

Process improvement is also a method to introduce process changes to improve the quality of a product or service, to better match customer and consumer needs.

### **9.9.4 Identify, Analyze and Improve the Key Processes**

An organization is only as good as its processes. To be able to make the necessary changes in an organization, one needs to understand the key processes of the company. Rummler and Brache suggested a model for running a Process Improvement and Management project (PI&M), containing the following steps:

- (i) Identify the process to be improved (based on a critical business issue): The identification of key processes can be a formal or informal exercise. The management team might select processes by

applying a set of criteria derived from strategic and tactical priorities, or process selection is based on obvious performance gaps. It is important to select the process(es) which have the greatest impact on a competitive advantage or customer requirement.

- (ii) Develop the objective(s) for the project based on the requirements of the process: The focus might be on quality improvement, productivity, cost, customer service or cycle time. The goal is however always the same; to get the key process under control.
- (iii) Select the members of the cross-functional team: A horizontal (cross-functional) analysis is carried out by a team composed of representatives of all functions involved in the process. While a consultant or in-house staff person can do the job, the quality of the analysis and the commitment to change is far greater with a cross-functional team.
- (iv) Document the current process by creating a flowchart or "organization map.": Describe the process regarding the Organizational level, the Process level and the Job/Performer level according to Rummier. Develop a cross-functional process map for the process.
- (v) Identify "disconnects" in the process: "Disconnections" are everything that inhibit the efficiency and effectiveness of the process. The identification should be categorized into the three levels: The Organizational level, the Process level and the Job/ Performer level.
- (vi) Recommend changes (organizational, in the process or in its execution): Categorize and prioritize the main problems and possibilities, evaluate alternative solutions. Develop a cross-functional process map for the recommended process.
- (vii) Establish process and sub-process measures: The process measures should reflect the objectives of the project.
- (viii) Implement the improvements.

The elements of a successful implementation effort

- Executive leadership and management commitment to see the project through to successful implementation.
- A clear statement of why the change is necessary.
- A clear vision of how the organization will be different after the changes.
- Sound, comprehensive recommendations.
- A sound implementation strategy and plan.
- Adequate resources and time.
- Communication of plans, roles and responsibilities, benefits, progress, resolutions.
- Willingness of affected functions and individuals to support the proposed changes.
- Implementation is effectively managed and executed.

This model for process analysis is just as useful for smaller processes as for larger and more complex processes. Completion of Steps 4-7 can take from three days to three months, depending on the complexity of the process and the extent of change required to remove the disconnects. Some of the benefits of this cross-functional team approach to process improvement are that the participants learn a tremendous amount about the overall business and their role in it. People earlier seen as unskilled might suddenly understand what is required from them, and will start behaving according to this. The increased understanding of the process will also increase the learning from additional formal training initiated, but also reduce the amount of training needed. When the organization finally understand what their key processes are they will more easily feel committed to the implementation of improvements.









**The Institute of Cost Accountants of India**  
(Statutory body under an Act of Parliament)

CMA Bhawan, 12, Sudder Street, Kolkata 700016  
Phones: +91-33-2252 1031 / 1034 / 1035 / 1602 / 2252 / 1492  
Fax: +91-33-22527993, +91-33-22522872  
Website: [www.icmai.in](http://www.icmai.in)