

**Paper-9 : OPERATIONS MANAGEMENT &
INFORMATION SYSTEMS**

SECTION A – OPERATIONS MANAGEMENT

1. (a) Write short notes on:

- (i) **Designing for Quality**
- (ii) **Types of processes**
- (iii) **Capital intensity**
- (iv) **Principles of Total Quality**
- (v) **Predictive Maintenance**
- (vi) **Diffusion**
- (vii) **Approach of Six Sigma**

Answer:

1. (a)

(i) Building product quality into the product design is the first step in producing products of superior quality. This is known as “**quality of design**” which is followed by “**quality of conformance.**” Quality of design refers to the quality specifications incorporated in the design. It consists of quality characteristics such as appearance, life, safety, maintenance and other features of the product. Quality of conformance is the degree to which the product actually conforms to the design specification. Designing products for quality consists of three aspects of design— (a) robust design, (b) design for production and (c) design for reliability.

(ii) **Types of Processes:** Basically, processes can be categorised as:

- (iii) Conversion processes, i.e., converting the raw materials into finished products (for example, converting iron ore into iron and then to steel). The conversion processes could be metallurgical or chemical or manufacturing or construction processes.
- (ii) Manufacturing processes can be categorised into (a) Forming processes, (b) Machining processes and (c) Assembly processes.
- (iii) Testing processes which involve inspection and testing of products (sometimes considered as part of the manufacturing processes).

Forming processes include foundry processes (to produce castings) and other processes such as forging, stamping, embossing and spinning. These processes change the shape of the raw material (a metal) into the shape of the workpiece without removing or adding material.

Machining processes comprise metal removal operations such as turning, milling, drilling, grinding, shaping, planning, boring etc.

Assembly processes involve joining of parts or components to produce assemblies having specific functions. Examples of assembly processes are welding, brazing, soldering, riveting, fastening with bolts and nuts and joining using adhesives.

(iii) **Capital intensity** is the mix of equipment and human skills in a production process. Capital intensity will be high if the relative cost of equipment is high when compared to the cost of human labour. **Capital intensity** means the predominant resource used in manufacturing, i.e., capital equipments and machines rather than labour. Decision regarding the amount of capital investment needed for equipments and machines is important for the design of a new process or the redesign of an existing one. As the capabilities of technology increase (for example automation), costs also will increase and managers have to decide about the extent of automation needed. While one advantage of adding capital intensity is significant increase in product quality and productivity, one big disadvantage can be high investment cost for low-volume operations.

(iv) **Principles of Total Quality:**

- Focus on the customer (Both internal & external)
- Participation and team work
- Employee involvement and empowerment
- Continuous improvement and learning.

(v) **Predictive Maintenance:** One of the newer types of maintenance that may be anticipated to gain increasing attention is called predictive maintenance. In this, sensitive instruments (e.g., vibration analysers, amplitude meters, audio gauges, optical tooling, pressure, temperature and resistance gauges) are used to predict trouble. Conditions can be measured periodically or on a continuous basis and this enables the maintenance people to plan for overhaul. This will allow an extension to the service life without fear of failure.

(vi) **Diffusion:** Diffusion is relevant to both process and product change. Process diffusion takes place when the overtime use of the process is diffused to other firms. Product diffusion refers primarily to the widespread use of the product among consumers rather than among firms. The rate of diffusion depends upon several factors and has many implications, particularly with respect to patents and monopoly.

(vii) **Six Sigma** is a very rigorous approach to improving quality within products and services. Processes that are critical to products and services must be analyzed in detail. Generally, Six Sigma will follow a four phase approach:

1. **Measure** – Determine the error or defect rate
2. **Analyze** – Understand the process
3. **Improve** – Reach for a higher Sigma
4. **Control** – Monitor through measurement

1. (b) **An 8 hours work measurement study in a plant reveals the following: Units produced = 320 nos. Idle time = 15%. Performance rating = 120%. Allowances = 12% of normal time. Determine the standard time per unit produced.**

Answer:

1. (b)

Observed time for 320 units = Working time - Idle time

$$= 8 - 8 \times 0.15$$

$$= 8 - 1.2$$

$$= 6.8 \text{ hours}$$

$$= 6.8 \times 60 = 408 \text{ minutes.}$$

$$\text{Observed time per unit} = \frac{408}{320} = 1.275 \text{ minutes}$$

$$\text{Normal time per unit} = \frac{\text{Observed time/unit} \times \text{Observed rating}}{\text{Standard rating}}$$

$$= \text{Observed time/unit} \times \text{Performance rating} = \frac{1.275 \times 120}{100} = 1.53 \text{ minutes}$$

Standard time/unit = Normal time/unit + Allowances

$$= 1.53 \text{ minutes} + 12\% \text{ of } 1.53 \text{ minutes}$$

$$= 1.53 + \frac{12}{100} \times 1.53$$

$$= (1.53 + 0.184) \text{ minutes} = 1.714 \text{ minutes}$$

- 1. (c) Sonar Gold Fields miners at 10th level have an accepted production standard of two trolley-loads an hour in an eight-hour working day. In addition to the mining of the gold-bearing soil, the miners have to do a few routine jobs such as cleaning, sharpening and maintaining the tools, for which they are paid a wage of ₹9 per hour upto a maximum of two hours per day. The base wage rate of the miners engaged in production/mining job is ₹6.60 per hour.**

If Subrato, a miner, produced 18 trolley-loads in addition to performing his routine tasks, what wages should he get at the end of the day?

Answer:

1. (c)

Subrato worked for $18 \div 2 = 9$ standard hours on the 'incentive job'.

This is equivalent to a productivity rate of:

$$9 \text{ hrs} / 6 \text{ hrs} = 150\%$$

The 'incentive wages' earned by Subrato are:

$$\frac{150}{100} \times (\text{₹}6.60) \times (6 \text{ hours}) = \text{₹}59.40$$

The 'non-incentive' wages earned by Subrato are:

$$(\text{₹}9.00) \times (2 \text{ hours}) = \text{₹}18.00$$

The total wages to be paid to him are

$$\text{₹}59.40 + \text{₹}18.00 = \text{₹}77.40$$

Revisionary Test Paper_Intermediate_Syllabus 2012_Dec 2015

1. (d) The demand for three months for 100 Watt bulbs are given below:

Period	January	February	March
Demand	500	600	800

If the weight assigned to the period of January, February and March are 0.25, 0.35 and 0.4 respectively, forecast the demand for the months of April by using Weighted Moving Average Method.

Answer:

1. (d)

$$D_1=500 \text{ Nos.} \quad W_1=0.25$$

$$D_2=600 \text{ Nos.} \quad W_2=0.35$$

$$D_3=800 \text{ Nos.} \quad W_3=0.4$$

$$\begin{aligned} \text{Therefore Weighted Moving Average} &= W_1 \times D_1 + W_2 \times D_2 + W_3 \times D_3 \\ &= 0.25 \times 500 + 0.35 \times 600 + 0.4 \times 800 \\ &= 125 + 210 + 320 \\ &= 655 \end{aligned}$$

The demand for the month of April is 655 Nos. of 100 Watt bulbs.

1. (e) A firm has four work centres, A, B, C & D, in series with individual capacities in units per day shown in the figure below.

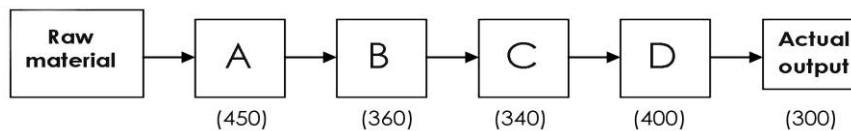

- (i) Identify the bottle neck centre.
- (ii) What is the system capacity?
- (iii) What is the system efficiency?

Answer:

1.(e)

(i) The bottle neck centre is the work centre having the minimum capacity. Hence, work centre 'C' is the bottleneck centre.

(ii) System capacity is the maximum units that are possible to produce in the system as a whole.

Hence, system capacity is the capacity of the bottle neck centre i.e., 340 units.

(iii) System efficiency = Actual output/ System capacity
= $(300/340) \times 100$ (i.e., maximum possible output) = 88.23%

1. (f) A workshop operates on 2 shifts of 8 hours per day. It has 20 machines. It works for 5 days in a week. Machine utilization is 90% and the efficiency of the machines is 85%. Calculate the designed/rated capacity of the workshop in standard hours.

Answer:

1.(f)

Rated capacity of the workshop = No. of shifts × No. of hour's in each shift × No. of days/week × No. of machines × Utilization factor × Efficiency

$$= 2 \times 8 \times 5 \times 20 \times 0.90 \times 0.85$$

$$= 1224 \text{ standard hour per week}$$

2. (a) Discuss Quality Control as a scope of operations management.

- (b) Explain the time-based strategies that focuses on reduction of time needed to accomplish tasks.

Answer:

2. (a) Quality Control (QC)

Quality Control may be defined as 'a system that is used to maintain a desired level of quality in a product or service'. It is a systematic control of various factors that affect the quality of the product. Quality Control aims at prevention of defects at the source, relies on effective feedback system and corrective action procedure.

Quality Control can also be defined as 'that Industrial Management technique by means of which product of uniform acceptable quality is manufactured'.

The main objectives of Quality Control are:

- (i) To improve the companies income by making the production more acceptable to the customers i.e. by providing long life, greater usefulness, maintainability, etc.
- (ii) To reduce companies cost through reduction of losses due to defects.
- (iii) To achieve interchangeability of manufacture in large-scale production.
- (iv) To produce optimal quality at reduced price.
- (v) To ensure satisfaction of customers with productions or services or high quality level, to build customer good will, confidence and reputation of manufacturer.
- (vi) To make inspection prompt to ensure quality control.
- (vii) To check the variation during manufacturing.

2. (b) Time-based strategy that focuses on reduction of time needed to accomplish tasks:

Time-based strategies focus on reducing the time required to accomplish various activities (e.g., develop new products or services and market them, respond to a change in customer demand, or deliver a product or perform a service). By doing so, organizations seek to improve service to the customer and to gain a competitive advantage over rivals who take more time to accomplish the same tasks.

Time-based strategies focus on reducing the time needed to conduct the various activities in a process. The rationale is that by reducing time, costs are generally less, productivity is higher, quality tends to be higher, product innovations appear on the market sooner, and customer service is improved.

Organizations have achieved time reduction in some of the following:

Revisory Test Paper_ Intermediate_ Syllabus 2012_ Dec 2015

Planning time: The time needed to react to a competitive threat, to develop strategies and select tactics, to approve proposed changes to facilities, to adopt new technologies, and so on.

Product/service design time: The time needed to develop and market new or redesigned products or services.

Processing time: The time needed to produce goods or provide services. This can involve scheduling repairing equipment, methods used, inventories, quality, training and the like.

Changeover time: The time needed to change from producing one type of product or service to another. This may involve new equipment settings and attachments, different methods, equipment, schedules, or materials.

Delivery time: The time needed to fill orders.

3. (a) Describe the designing for the customer approach and designing for manufacture and assembly approach in relation to product design.

(b) State the meaning of Value Engineering/Value Analysis in Product Design.

Answer:

3. (a)

Designing for the Customer

Designing for aesthetics and for the user is generally termed industrial design which is probably the most neglected area by manufacturers. In many products we use, parts are inaccessible, operation is too complicated or there is no logic to setting and controlling the function of the product. Sometimes worst conditions exist, metal edges are sharp and consumers cut their hands trying to reach for adjustment or repairs. Many products have too many features far more than necessary and for instance many electronic products have too many features which the customers cannot fully make use of (operate). One approach to getting the **voice of the customer** into the design specification of a product is **quality function deployment (QFD)**. This approach uses interfunctional teams from marketing, design engineering and manufacturing to incorporate the features sought by the customers in the product at the stage of product design. The customer's requirements (with its importance weightage) and the technical characteristics of the product are related to each other in a matrix called **house of quality**. The customers are asked to compare the company's products to the competitor's products. The technical characteristics are then evaluated to support or refute the customer perception of the product. This data is then used to evaluate the strengths and weaknesses of the product in terms of technical characteristics.

Designing for Manufacture and Assembly (DFMA)

Traditionally the attitude of designers has been "we design it, you build it" which is termed as "**over-the-wall approach**", where the designer is sitting on one side of the wall and throwing the design over the wall to the manufacturing engineers. The manufacturing engineers have to deal with the problems that arise because they were not involved in the design effort. This problem can be overcome by an approach known as **concurrent engineering** (or simultaneous engineering). Concurrent engineering means bringing design and manufacturing people together early in the design phase to simultaneously develop the product and processes for manufacturing the product. Recently this concept has been enlarged to include manufacturing personnel, design personnel, marketing and purchasing personnel in loosely integrated cross-functional teams. In addition, the views of suppliers and customers are also sought frequently. This will result in product designs that will reflect customer wants as well as manufacturing capabilities in the design stage itself. **Design for Manufacturing (DFM)** and **Design for Assembly (DFA)** are related concepts in manufacturing. The term design for manufacturing is used to indicate the designing of products that are compatible with an organisation's capability. Design for assembly focuses on reducing the

Revisionary Test Paper_Intermediate_Syllabus 2012_Dec 2015

number of parts in a product or on assembly methods and sequence that will be employed. Designing for manufacture includes the following guidelines:

- (a) Designing for minimum number of parts.
- (b) Developing modular design.
- (c) Designing for minimum part variations (i.e., communisation or using standardised parts) and
- (d) Designing parts for ease of fabrication.

3. (b) Value Engineering/Value Analysis in Product Design: Value engineering or value analysis is concerned with the improvement of design and specifications at various stages such as research, development, design and product development. Benefits of value engineering are:

- (i) Cost reduction.
- (ii) Less complex products.
- (iii) Use of standard parts/components.
- (iv) Improvement in functions of the product.
- (v) Better job design and job safety.
- (vi) Better maintainability and serviceability.
- (vii) Robust design.

Value engineering aims at cost reduction at equivalent performance. It can reduce costs to the extent of 15% to 70% without reducing quality. While value engineering focuses on preproduction design improvement, value analysis, a related technique seeks improvements during the production process.

Once launched, even good products have limited lives and, to remain viable, the organization seeks a flow of new product possibilities. Let's examine the product's birth-to-mortality pattern.

4. (a) 'Process choice determines whether resources are organized around products of processes in order to implement the flow strategy'. Discuss the five basic process choice.

(b) Explain JIT system in relation to service sector.

Answer:

4. (a) Process choice determines whether resources are organised around products or processes in order to implement the flow strategy. It depends on the volumes and degree of customisation to be provided.

Process Choice: The production manager has to choose from five basic process types — (i) job shop, (ii) batch, (iii) repetitive or assembly line, (iv) continuous and (v) project.

(i) Job shop process: It is used in job shops when a low volume of high-variety goods are needed. Processing is intermittent, each job requires somewhat different processing requirements. A job shop is characterised by high customisation (made to order), high flexibility of equipment and skilled labour and low volume. A tool and die shop is an example of job shop, where **job process** is carried out to produce one-of-a kind of tools. Firms having job shops often carry out job works for other firms. A job shop uses a flexible flow strategy, with resources organised around the process.

(ii) Batch process: Batch processing is used when a moderate volume of goods or services is required and also a moderate variety in products or services. A batch process differs from the job process with respect to volume and variety. In batch processing, volumes are

higher because same or similar products or services are repeatedly provided, examples of products produced in batches include paint, ice cream, soft drinks, books and magazines.

- (iii) **Repetitive process:** This is used when higher volumes of more standardised goods or services are needed. This type of process is characterised by slight flexibility of equipment (as products are standardised) and generally low labour skills. Products produced include automobiles, home appliances, television sets, computers, toys etc. Repetitive process is also referred to as **line process** as it include **production lines** and **assembly lines** in mass production. Resources are organised around a product or service and materials move in a line flow from one operation to the next according to a fixed sequence with little work-in-progress inventory. This kind of process is suitable to “**manufacture-to-stock**” strategy with standard products held in finished goods inventory. However, “**assemble-to-order**” strategy and “**mass customisation**” are also possible in repetitive process.
- (iv) **Continuous process:** This is used when a very highly standardised product is desired in high volumes. These systems have almost no variety in output and hence there is no need for equipment flexibility. A continuous process is the extreme end of high volume, standardised production with rigid line flows. The process often is capital intensive and operate round the clock to maximise equipment utilisation and to avoid expensive shut downs and shut ups. Examples of products made in continuous process systems include petroleum products, steel, sugar, flour, paper, cement, fertilisers etc.
- (v) **Project process:** It is characterised by high degree of job customisation, the large scope for each project and need for substantial resources to complete the project. Examples of projects are building a shopping centre, a dam, a bridge, construction of a factory, hospital, developing a new product, publishing a new book etc. Projects tend to be complex, take a long time and consist of a large number of complex activities. Equipment flexibility and labour skills can range from low to high depending on the type of projects.

4. (b) In a just-in-time (JIT) system

The production and provision of service starts as soon as the customer arrives to avail the service. The customer's involvement in the service process is imperative. This is known as the 'pull' production system in manufacturing and was inspired by the retailing services in the US supermarkets. The production process is initiated only when the customer places the order for the product and the raw material is 'pulled' into the various constituents of the production process according to the quantity of the order placed by the customer. Thus, the 'push' production system prevalent in many manufacturing organizations cannot be applied to service organizations. The 'push' production system results in 'pushing' the raw material in the production system and creation of inventories (work-in-process or finished goods). This is not possible in services, as they cannot be inventories.

5. (a) Describe the objectives of production planning and control.

(b) State the uses of Work Sampling Technique.

Answer:

5. (a) The following are the objectives of production planning and control:

- (i) To deliver quality goods in required quantities to the customer in the required delivery schedule to achieve maximum customer satisfaction and minimum possible cost.
- (ii) To ensure maximum utilization of all resources.
- (iii) To ensure production of quality products.
- (iv) To minimise the product through-put time or production/manufacturing cycle time.

- (v) To maintain optimum inventory levels.
- (vi) To maintain flexibility in manufacturing operations.
- (vii) To co-ordinate, between labour and machines and various supporting departments.
- (viii) To plan for plant capacities for future requirements.
- (ix) To remove bottle-necks at all stages of production and to solve problems related to production.
- (x) To ensure effective cost reduction and cost control.
- (xi) To prepare production schedules and ensure that promised delivery dates are met.
- (xii) To produce effective results for least total cost.
- (xiii) To establish routes and schedules for work that will ensure optimum utilization of materials, labour and equipments and machines and to provide the means for ensuring the operation of the plant in accordance with these plans.
- (xiv) The ultimate objective is to contribute to profit of the enterprise.

5. (b) Uses of Work Sampling Technique

1. To estimate the percentage of a protracted time period consumed by various activity states of a resource such as equipment, machines or operators.
2. To determine the allowances for inclusion in standard times.
3. To indicate the nature of the distribution of work activities within a gang operation.
4. To estimate the percentage of utilization of groups of similar machines or equipment.
5. To indicate how materials handling equipments are being used.
6. To provide a basis for indirect labour time standards.
7. To determine the productive and non-productive utilization of clerical operations.
8. To determine the standard time for a repetitive operation as an attention to stop watch method.

6. (a) Customers arrive at a booking office window being manned by a single individual at a rate of 25 per hour. The time required to serve a customer has exponential distribution with a mean of 120 seconds. Find the average waiting time of a customer.

(b) Trucks arrive at a factory for collecting finished goods for transportation to distant markets. As and when they come they are required to join a waiting line and are served on first come, first served basis. Trucks arrive at the rate of 10 per hour whereas the loading rate is 15 per hour. It is also given that arrivals are Poisson and loading is exponentially distributed. Transporters have complained that their trucks have to wait for nearly 12 hours at the plant. Examine whether the complaint is justified. Also determine probability that the loaders are idle in the above problem.

(c) In a Tool Crib manned by a single Assistant, operators arrive at the tool crib at the rate of 10 per hour. Each operator needs 3 minutes on an average to be served. Find out the loss of production due to waiting of an operator in a shift of 8 hours if the rate of production is 100 units per shift.

Answer:

6. (a) Here we are given:

$$\text{Arrival rate } (\lambda) = 25 \text{ per hour}$$

Revisionary Test Paper_Intermediate_Syllabus 2012_Dec 2015

Service rate (μ) = $\frac{60 \times 60}{120} = 30$ per hour.

Average waiting time of a customer in queue:

$$W_q = \frac{\lambda}{\mu(\mu - \lambda)} = \frac{25}{30(30 - 25)} = \frac{1}{6} \text{ hrs. or 10 minutes.}$$

6. (b) Here we are given:

$\lambda = 10$ per hour, $\mu = 15$ per hour

Average waiting time in the queue

$$= \frac{\lambda}{\mu(\mu - \lambda)} = \frac{10}{15(15 - 10)} = \frac{10}{75} \text{ hr. or 8 mins.}$$

In no way, can the claim be justified because waiting time is less than 12 hours. Now, the probability of loaders lying idle is :

$$P_0 = 1 - \frac{\lambda}{\mu} = 1 - \frac{10}{15} = \frac{5}{15} \text{ or 33.33\%}$$

6. (c) Here we are given :

$\lambda = 10$ /hr. $\mu = 20$ /hr.

Average waiting time

$$= \frac{\lambda}{\mu(\mu - \lambda)} = \frac{10}{20(20 - 10)} = \frac{1}{20} \text{ hr.}$$

Average waiting time per shift of 8 hours

$$= \frac{8}{20} = \frac{2}{5} \text{ hr.}$$

Loss of production due to waiting = $\frac{100}{8} \times \frac{2}{5} = 5$ units.

7. (a) A project consists of seven activities for which the relevant data are given below:

(i) Draw the network

(ii) Name the critical path

Activity	Preceding activity	Duration (Days)
A	-	4
B	-	7
C	-	6
D	A,B	5
E	A,B	7
F	C,D,E	6
G	C,D,E	5

Revisionary Test Paper_ Intermediate_ Syllabus 2012_ Dec 2015

- (b) Draw the network for the following activities and find critical path and total duration of project:

Activity	Dependence	Duration (Days)	Activity	Dependence	Duration (Days)
A	-	9	G	F,C	10
B	-	4	H	B	8
C	-	7	I	E,H	6
D	A,B	8	J	E,H	9
E	B	7	K	C,D,F,J	10
F	B	5	L	K	2

- (c) A company had planned its operations as follows: (Duration in days)

Activity	1-2	2-4	1-3	3-4	1-4	2-5	4-7	3-6	5-7	6-8	7-8
Duration	7	8	8	6	6	16	19	24	9	7	8

- (i) Draw the network and find the critical paths
- (ii) After 15 days of working, the following progress is noted:
- Activities 1-2, 1-3, and 1-4 completed as per original schedule
 - Activity 2-4 is in progress and will be completed in 4 more days.
 - Activity 3-6 is in progress and will be completed in 17 more days.
 - The staff members for activity 3-6 are specialized. They are directed to complete 3-6 and undertake an activity 6-7 which will require 7 days. This re-arrangement arose due to a modification in specialization.
 - Activity 6-8 will be completed in 4 days instead of originally planned 7 days.
 - There is no change in other activities.

Update the net work diagram after 15 days of start of work based on the facts given above. Indicate the revised critical path along with duration.

Answer:

7. (a)

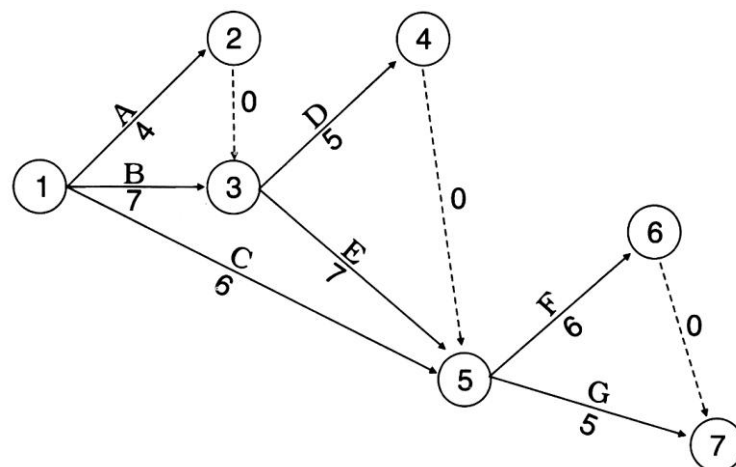

Revisionary Test Paper_ Intermediate_ Syllabus 2012_ Dec 2015

Paths	Duration (days)	Paths	Duration (days)
1-2-3-4-5-6-7	$4 + 0 + 5 + 0 + 6 + 0 = 15$	1-3-4-5-7	$7 + 5 + 0 + 5 = 17$
1-2-3-4-5-7	$4 + 0 + 5 + 0 + 5 = 14$	1-3-5-7	$7 + 7 + 5 = 19$
1-2-3-5-6-7	$4 + 0 + 7 + 6 = 17$	1-3-5-6-7	$7 + 7 + 6 + 0 = 20$ CRITICAL PATH B-E-F
1-2-3-5-7	$4 + 0 + 7 + 5 = 16$	1-5-6-7	$6 + 6 + 0 = 12$
1-3-4-5-6-7	$7 + 5 + 0 + 6 + 0 = 18$	1-5-7	$6 + 5 = 11$

7.(b)

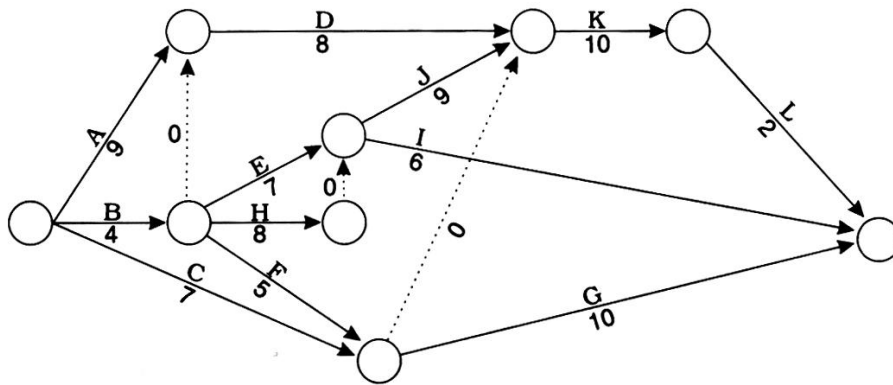

Paths	Duration	Paths	Duration
ADKL	$9 + 8 + 10 + 2 = 29$	BEI	$4 + 7 + 6 = 17$
BDKL	$4 + 8 + 10 + 2 = 24$	BEJKL	$4 + 7 + 9 + 10 + 2 = 32$ (Critical path)
CG	$7 + 10 = 17$	BHI	$4 + 8 + 6 = 18$
CKL	$7 + 10 + 2 = 19$	BFG	$4 + 5 + 10 = 19$

7. (c) (i)

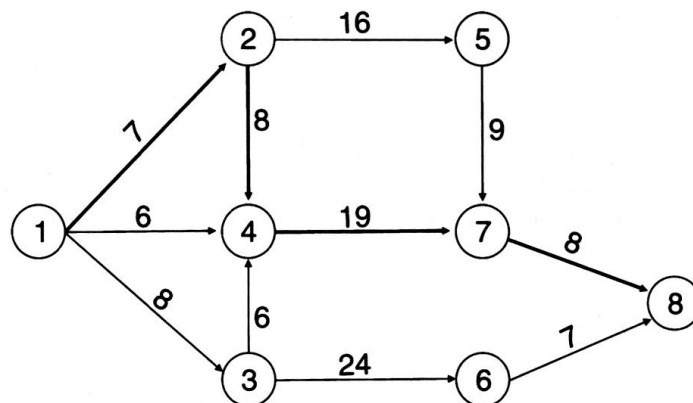

Paths	Duration (weeks)	Paths	Duration (weeks)
1-2-5-7-8	40	1-3-4-7-8	41
1-2-4-7-8 Critical path	42	1-3-6-8	39

1-4-7-8	33		
---------	----	--	--

(ii)

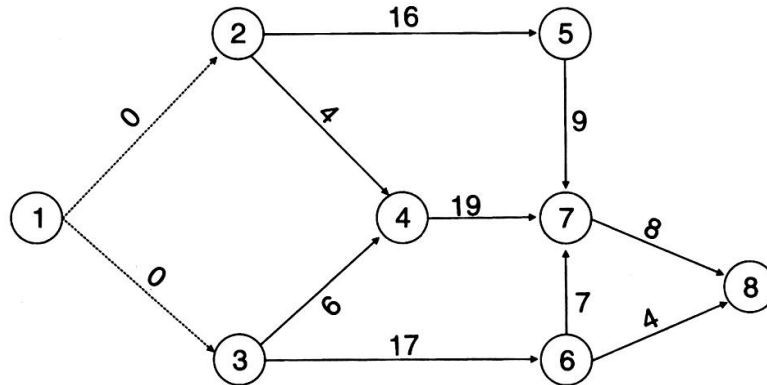

Paths	Duration (weeks)	Paths	Duration (weeks)
1-2-5-7-8	$0 + 16 + 9 + 8 = 33$	1-3-6-8	$0 + 17 + 4 = 21$
1-2-4-7-8	$0 + 4 + 19 + 8 = 31$	1-3-6-7-8	$0 + 17 + 7 + 8 = 32$
1-3-4-7-8	$0 + 6 + 19 + 8 = 33$		

There are two critical paths: 1-2-5-7-8 and 1-3-4-7-8. Duration 33 weeks.

8. (a) A Ltd trades in a perishable commodity. Each day, A Ltd receives supplies of goods from a wholesaler but the quantity supplied is a random variable, as is subsequent retail customer demand for the commodity. Both supply and demand are expressed in batches of 50 units and over the past working year (300 days) A Ltd has kept the records of supply and demands. The records are as follows:

Wholesale supplies	No. of days occurring	Customers' demand	No. of days occurring
50	60	50	60
100	90	100	60
150	90	150	150
200	60	200	30

A Ltd buys the commodity at ₹ 6 per unit and sells at the rate of ₹ 10 per unit. Unsold units at the end of the day are worthless as there are no storage facilities. A Ltd. estimates that each unit of unsatisfied demand on any day costs them ₹ 2. Use the following random numbers: (8, 4), (8, 0), (3, 3), (4, 7), (9, 6), (1, 5). Simulate six days trading and estimate the annual profit.

- (b) A single counter ticket booking centre employs one booking clerk. A passenger on arrival immediately goes to the booking counter for being served if the counter is free. If, on the other hand, the counter is engaged, the passenger will have to wait. The passengers are served on first come first served basis. The time of arrival and the time of service varies from one minute to six minutes. The distribution of arrival and service time is as under:

Arrival/Service Time (Minutes)	Arrival (Probability)	Service (Probability)
1	0.05	0.10

Revisionary Test Paper_ Intermediate_ Syllabus 2012_ Dec 2015

2	0.20	0.20
3	0.35	0.40
4	0.25	0.20
5	0.10	0.10
6	0.05	0

- (i) Simulate the arrival and service of 10 passengers starting from 9 A.M. by using the following random numbers in pairs respectively for arrival and service. Random numbers 60 09, 16 12, 08 18, 36 65, 38 25, 07 11, 08 79, 59 61, 53 77, 03 10.
- (ii) Determine the total duration of:
- (1) Idle time of booking clerk and (2) Waiting time of passengers.

Answer:

8.(a)

Probability distribution (wholesale supplies)

Wholesale Supplies	Probability	Cum Probability	Range	Range for simulation
50	0.2	0.2	0-0.2	0-0.1
100	0.3	0.5	0.2 - 0.5	0.2 - 0.4
150	0.3	0.8	0.5 - 0.8	0.5 - 0.7
200	0.2	1.00	0.8 - 1.00	0.8 - 0.9

Probability distribution (Customers demand)

Demand	Probability	Cum Probability	Range	Range for simulation
50	0.2	0.2	0-0.2	0-0.1
100	0.2	0.4	0.2 - 0.4	0.2 - 0.3
150	0.5	0.9	0.4 - 0.9	0.4 - 0.8
200	0.1	1.0	0.9-1.0	0.9 - 0.9

Day	Supply	Demand	Sales (A) ₹	Cost (B) ₹	Loss on shortage (C) ₹	Profit (A -B-C) ₹
1	200	150	1500	1200		300
2	200	50	500	1200		-700
3	100	100	1000	600		400
4	100	150	1000	600	100	300
5	200	150	1500	1200		300
6	50	150	500	300	200	0
Total						600

Profit in 6 days: ₹ 600

Profit in 300 days ₹ 30,000

8. (b)

Probability Distribution (Arrival)

Time	Probability	Cum. Probability	Range	Range for simulation
1m	0.05	0.05	0 - 0.05	0 - 0.04
2m	0.20	0.25	0.05 - 0.25	0.05 - 0.24
3m	0.35	0.60	0.25 - 0.60	0.25 - 0.59

Revisionary Test Paper_Intermediate_Syllabus 2012_Dec 2015

4m	0.25	0.85	0.60 - 0.85	0.60 - 0.84
5m	0.10	0.95	0.85 - 0.95	0.85 - 0.94
6m	0.05	1.00	0.95 - 1.00	0.95 - 0.99

Probability Distribution (Service)

Time	Probability	Cum Probability	Range	Range for simulation
1m	0.10	0.10	0-0.10	0 - 0.09
2m	0.20	0.30	0.10-0.30	0.10 - 0.29
3m	0.40	0.70	0.30 - 0.70	0.30 - 0.69
4m	0.20	0.90	0.70 - 0.90	0.70 - 0.89
5m	0.10	1.00	0.90- 1.00	0.90 - 0.99

Passenger S. No.	Arrival time	Service begins	Service completes	Waiting time	Idle time
1	9.04	0.04	9.05	Nil	4m
2	9.06	9.06	9.08	Nil	1m
3	9.08	9.08	9.10	Nil	nil
4	9.11	9.11	9.14	Nil	1m
5	9.14	9.14	9.16	Nil	Nil
6	9.16	9.16	9.18	Nil	Nil
7	9.18	9.18	9.22	Nil	Nil
8	9.21	9.22	9.25	1m	Nil
9	9.24	9.25	9.29	1m	Nil
10	9.25	9.29	9.31	4m	Nil
Total				6m	6m

9. (a)

Four operators O1, O2, O3 and O4 are available to a manager who has to get four jobs J1, J2, J3 and J4 done by assigning one job to each operator. Given the time needed by different operators for different jobs in the matrix →		J1	J2	J3	J4
	O1	12	10	10	8
	O2	14	12	15	11
	O3	6	10	16	4
	O4	8	10	9	7

How should the manager assign the jobs so that the total time needed for all four jobs in minimum?

(b)

Four operators O1, O2, O3 and O4 are available to a manager who has to get four jobs J1, J2, J3 and J4 done by assigning one job to each operator. Given the time needed by different operators for different jobs in the matrix →		J1	J2	J3	J4
	O1	12	10	10	8
	O2	14	12	15	11
	O3	6	10	16	4
	O4	8	10	9	7

If job J2 is not to be assigned to operator O2, how should the manager assign the jobs so that the total time needed for all four jobs is minimum?

Revisionary Test Paper_ Intermediate_ Syllabus 2012_ Dec 2015

Answer:

9. (a)

Row reduction					Column reduction				
	J1	J2	J3	J4		J1	J2	J3	J4
○1	4	2	2	0	○1	3	1	0	0
○2	3	1	4	0	○2	2	0	2	0
○3	2	6	12	0	○3	1	5	10	0
○4	1	3	2	0	○4	0	2	0	0

Minimum lines to cut zeros

	J1	J2	J3	J4
○1	3	1	0	0
○2	2	0	2	0
○3	1	5	10	0
○4	0	2	0	0

As the minimum number of lines are equal to order of matrix, optimal assignment should be made.

Optimal Assignment

	J1	J2	J3	J4
○1	3	1	0	0
○2	2	0	2	0
○3	1	5	10	0
○4	0	2	0	0

	Job	Time
○1	J3	10
○2	J2	12
○3	J4	4
○4	J1	8
Total		34

9. (b)

Row reduction					Column reduction				
	J1	J2	J3	J4		J1	J2	J3	J4
○1	4	2	2	0	○1	3	0	0	0
○2	3	-	4	0	○2	2	-	2	0
○3	2	6	12	0	○3	1	4	10	0
○4	1	3	2	0	○4	0	1	0	0

Revisionary Test Paper_Intermediate_Syllabus 2012_Dec 2015

Minimum No. of lines

	J1	J2	J3	J4
O1	3	0	0	0
O2	2	-	2	0
O3	1	4	10	0
O4	0	1	0	0

As the minimum number of lines are not equal to order of matrix, let's take steps to increase the number of zeros.

	J1	J2	J3	J4
O1	3	0	0	1
O2	1	-	1	0
O3	0	3	9	0
O4	0	1	0	1

Minimum No. of lines

	J1	J2	J3	J4
O1	3	0	0	1
O2	1	-	1	0
O3	0	3	9	0
O4	0	1	0	1

As the minimum number of lines are equal to order of matrix, optimal assignment should be made.

Optimal Assignment

	J1	J2	J3	J4
O1	3	0	0	1
O2	1	-	1	0
O3	0	3	9	0
O4	0	1	0	1

Time requirement:

	Job	Time
O1	J2	10
O2	J4	11
O3	J1	6
O4	J3	9
Total		36

10. To stimulate interest and provide an atmosphere for intellectual discussion, a finance faculty in a management school decides to hold special seminars on four contemporary topics – leasing, portfolio management, private mutual funds, swap and options. Such seminars should be held once per week in the afternoons. However the scheduling of these seminars (one for each topic and not more than one seminar per afternoon) has to be done carefully so that the number of students unable to attend is kept to a minimum. A careful study indicates that the number of students who cannot attend a particular seminar on a specific day is as follows:

Revisionary Test Paper_ Intermediate_ Syllabus 2012_ Dec 2015

	Leasing	Portfolio Management	Private MFs	Swaps and options
Monday	50	40	60	20
Tuesday	40	30	40	30
Wednesday	60	20	30	20
Thursday	30	30	20	30
Friday	10	20	10	30

Find an optimal schedule of the seminars. Also find out the total number of students who will be missing at least one seminar.

Answer:

10.

	Leasing	Portfolio Management	Private MFs	Swaps and options	Dummy
Mon	50	40	60	20	0
Tues	40	30	40	30	0
Wed	60	20	30	20	0
Thurs	30	30	20	30	0
Fri	10	20	10	30	0

Row subtraction is not required as there is zero in each row.

Column subtraction

	Leasing	Portfolio Management	Private MFs	Swaps and options	Dummy
Mon	40	20	50	0	0
Tues	30	10	30	10	0
Wed	50	0	20	0	0
Thurs	20	10	10	10	0
Fri	0	0	0	10	0

Minimum No. of lines

	Leasing	Portfolio Management	Private MFs	Swaps and options	Dummy
Mon	40	20	50	0	0
Tues	30	10	30	10	0
Wed	50	0	20	0	0
Thurs	20	10	10	10	0
Fri	0	0	0	10	0

As the minimum number of lines are not equal to order of matrix, let's take steps to increase the number of zeros.

	Leasing	Portfolio Management	Private MFs	Swaps and options	Dummy
Mon	40	20	50	0	10
Tues	20	0	20	10	0

Revisionary Test Paper_ Intermediate_ Syllabus 2012_ Dec 2015

Wed	50	0	20	0	10
Thurs	10	0	0	0	0
Fri	0	0	0	10	10

Minimum No. of lines

	Leasing	Portfolio Management	Private MFs	Swaps and options	Dummy
Mon	40	20	50	0	10
Tues	20	0	20	0	0
Wed	50	0	20	0	10
Thurs	10	0	0	0	0
Fri	0	0	0	10	10

As the minimum number of lines are equal to order of matrix, optimal assignment should be made.

Optimal Assignment

	Leasing	Portfolio Management	Private MFs	Swaps and options	Dummy
Mon	40	20	50	0	10
Tues	20	0	20	0	0
Wed	50	0	20	0	10
Thurs	10	0	0	0	0
Fri	0	0	0	10	10

Schedule:

	Portfolio Management	Swaps and options
Mon	Swap and options	20
Tues	No seminar	-
Wed	Portfolio	20
Thurs	MF	20
Fri	Leasing	10
Total		70

11. (a)

	Store 1	Store 2	Store 3	Total supplies
Plant 1	49	60	56	14
Plant 2	45	55	53	26
Plant 3	50	80	70	36
Plant 4	52	64	55	22
Total Demand	20	32	25	

Find the initial solution by least cost method. Is the initial solution feasible?

Revisionary Test Paper_ Intermediate_ Syllabus 2012_ Dec 2015

(b)

	Warehouse 1	Warehouse 2	Warehouse 3	Total supplies
Factory 1	53	54	52	30
Factory 2	52	51	55	25
Factory 3	34	53	53	20
Total Demand	20	20	35	75

Find the initial solution by least cost method. Is the initial solution feasible?

(c)

	Destination 1	Destination 2	Destination 3	Destination 4	Total supplies
Source 1	48	60	56	58	14
Source 2	45	55	53	60	26
Source 3	50	65	60	62	36
Total Demand	20	32	25	21	

Find the initial solution by North-west Corner method. Is the initial solution feasible?

Answer:

11. (a)

Total demand = 77. Total supplies = 98. Introduce dummy store demanding 21 with zero transportation cost.

	Store 1	Store 2	Store 3	Store 4	Total supplies
Plant 1	49	60	56	0	14
Plant 2	45	20	55	6	26
Plant 3	50	80	32	4	36
Plant 4	52	64	55	1	21
Total Demand	20	32	25	21	98

Initial Solution:

From	Plant 1	Plant 2	Plant 2	Plant 3	Plant 3	Plant 4	Plant 4
To	Store 3	Store 1	Store 3	Store 2	Store 3	Store 3	Store 4
Units	14	20	6	32	4	1	Dummy

Feasibility test	$m + n - 1 = 7$	No. of allocations = 7	The solution is feasible
------------------	-----------------	------------------------	---------------------------------

Revisionary Test Paper_ Intermediate_ Syllabus 2012_ Dec 2015

11. (b)

Opportunity Loss Matrix

	Warehouse 1	Warehouse 2	Warehouse 3	Total supplies
Factory 1	2 (10)	1 (20)	3	30
Factory 2	3	4	0 (25)	25
Factory 3	21 (10)	2	2 (10)	20
Total Demand	20	20	35	75

Initial solution

From	Factory 1	Factory 1	Factory 2	Factory 3	Factory 3
To	WH 1	WH 2	WH 3	WH 1	WH 3
Units	10	20	25	10	10
Feasibility test	$m + n - 1 = 5$		No. of allocations = 5		The solution is feasible

11. (c)

Total demand 98. Total supply 76. Introduce dummy source with supply as 22 and transportation cost per unit to be zero.

	Destination 1	Destination 2	Destination 3	Destination 4	Total supplies
Source 1	(14)				14
Source 2	(6)	(20)			26
Source 3		(12)	(24)		36
Source 4 (Dummy)			(1)	(21)	22
Total Demand	20	32	25	21	98

Initial Solution:

From	Source 1	Source 2	Source 2	Source 3	Source 3	Source 4	Source 4
To	D-1	D-1	D-2	D-2	D-3	D-3	D-4
Units	14	6	20	12	24	Dummy	Dummy
Feasibility test	$m + n - 1 = 7$			No. of allocations = 7		The solution is feasible	

12. (a) A farm is engaged in breeding cows. The cows are fed on various products grown on the farm. In view of the need to ensure certain nutrient constituents (call them as X, Y and Z). It becomes necessary to two additional products say A and B. One unit of A contains 36 units of X, 3 units of Y and 20 units of Z. One unit of B contains 6 units of X, 12 units of Y and 10 units of Z. The minimum requirement of X, Y and Z is 108 units, 36

Revisionary Test Paper_ Intermediate_ Syllabus 2012_ Dec 2015

units and 100 units respectively. Product A costs ₹ 20 per unit and product B costs ₹ 40 per unit. Formulate LPP to minimize the total cost.

(b) A city hospital has the following minimal daily requirement for nurses:

Period	Clock time (24 hours day)	Minimal number of nurses required
1	6 AM - 10 AM	2
2	10 AM - 2 PM	7
3	2 PM- 6 PM	15
4	6 PM- 10 PM	8
5	10 PM – 2 AM	20
6	2 AM - 6 AM	6

Nurses report to the hospital at the beginning of each period and work for consecutive 8 hours. The hospital wants to determine the minimal number of nurses to be employed so that there will be sufficient number of nurses available for each period. Formulate LPP. Do not solve.

Answer:

12. (a) Let's purchase x units of A and y units of B

Objective function : $Z = \text{Minimize } 20x + 40y$

Subject to:

$$36x + 6y \geq 108$$

$$3x + 12y \geq 36$$

$$20x + 10y \geq 100$$

$$x, y, z \geq 0$$

12. (b) Let the number of nurses reporting at 6 AM = x_1
 Let the number of nurses reporting at 10 AM = x_2
 Let the number of nurses reporting at 2 PM = x_3
 Let the number of nurses reporting at 6 PM = x_4
 Let the number of nurses reporting at 10 PM = x_5
 Let the number of nurses reporting at 2 AM = x_6

Objective function: Minimize $x_1 + x_2 + x_3 + x_4 + x_5 + x_6$.			
Subject to: →	(i) $x_6 + x_1 \geq 2$	(ii) $x_1 + x_2 \geq 7$	(iii) $x_2 + x_3 \geq 15$
(iv) $x_3 + x_4 \geq 8$	(v) $x_4 + x_5 \geq 20$	(vi) $x_5 + x_6 \geq 6$	(vii) $x_1, x_2, x_3, x_4, x_5, x_6 \geq 0$

13. (a) Compute the production cost per piece from the following data,

- (i) Direct material per piece - ₹ 2
- (ii) Wage rate ₹ 2,000 per month consisting of 25 working days and 8 hours per day.
- (iii) Overheads expressed as a percentage of direct labour cost - 200%.
- (iv) The time for manufacture of 4 pieces of the item was observed during time study. The manufacture of the item consists of 4 elements a, b, c and d. The data

Revisionary Test Paper_ Intermediate_ Syllabus 2012_ Dec 2015

collected during the time study are as under. Time observed (in minutes) during the various cycles are as below:

Element	Cycle 1	Cycle 2	Cycle 3	Cycle 4	Element rating on B.S. Scale (0-1 00)
a	1.2	1.3	1.3	1.4	85
b	0.7	0.6	0.65	0.75	120
c	1.4	1.3	1.3	1.2	90
d	0.5	0.5	0.6	0.4	70

The personal, fatigue and delay allowance may be taken as 25%.

(b) A manager has to decide about the number of machines to be purchased. He has three options i.e., purchasing one, or two or three machines. The data are given below.

Number of machine	Annual fixed cost (₹)	Corresponding range of output
One	12,000	0 to 300
Two	15,000	301 to 600
Three	21,000	601 to 900

Variable cost is ₹20 per unit and revenue is ₹50 per unit

- (i) Determine the break-even point for each range
- (ii) If projected demand is between 600 and 650 units how many machines should the manager purchase?

Answer:

13.(a)

Step No. 1: Calculation of the standard time for the job based on the data given.

Element	Average observed time (O.T) (minutes)	Normal time (minutes) = $\left(\frac{\text{O.T} \times \text{Observed rating}}{\text{Standard rating}} \right)$
a	$\frac{1.2+1.3+1.3+1.4}{4} = 1.3$	$\frac{1.3 \times 85}{100} = 1.105$
b	$\frac{0.7+0.6+0.65+0.75}{4} = 0.675$	$\frac{0.675 \times 120}{100} = 0.81$
c	$\frac{1.4+1.3+1.3+1.2}{4} = 1.3$	$\frac{1.3 \times 90}{100} = 1.17$
d	$\frac{0.5+0.5+0.6+0.4}{4} = 0.5$	$\frac{0.5 \times 70}{100} = 0.35$
Normal time for the job = 3.435 minutes		

Standard time for the job = Normal time + Allowances

$$= 3.435 + \frac{25}{100} \times 3.435$$

$$= 3.435 + 0.858 = 4.29 = 4.3 \text{ minutes}$$

As this time is the time taken for producing 4 pieces.

$$\text{Standard time per piece} = \frac{4.3}{4} = 1.075 \text{ minutes}$$

Revisionary Test Paper_ Intermediate_ Syllabus 2012_ Dec 2015

Step No. 2: Calculation of costs

Direct labour cost of the job = Standard time/job in hour x Labour rate/hour

$$\text{Labour rate per hour} = \frac{2,000}{25 \times 8} = ₹ 10$$

$$\text{Direct labour cost for the job} = \frac{1.075}{60} \times 10 = ₹ 0.18$$

Direct material cost per piece = ₹ 2

$$\text{Overhead cost 200\% of labour cost} = \frac{200}{100} \times 0.18 = ₹ 0.36$$

$$\text{Total production cost per piece} = 0.18 + 2.0 + 0.36 = ₹ 2.54$$

13.(b)

(i) Break-even point

Let QBEP be the break even point.

FC = Fixed cost, R = Revenue per unit, VC = Variable cost

Then $QBEP \times R = FC + (VC) \times QBEP$

$$QBEP = \frac{FC}{R - VC}$$

Let Q1 be the break-even-point for one machine option

$$\text{Then, } Q1 = \frac{12,000}{(50 - 20)} = \frac{12,000}{30} = 400 \text{ units}$$

(Not within the range of 0 to 300)

Let Q2 be the break-even-point for two machines option.

$$\text{Then, } Q2 = \frac{15,000}{(50 - 20)} = \frac{15,000}{30} = 500 \text{ units}$$

(Within the range of 301 to 600)

Let Q3 be the break-even-point for three machines option.

$$\text{Then, } Q3 = \frac{21,000}{(50 - 20)} = \frac{21,000}{30} = 700 \text{ units}$$

(Within the range of 601 to 900)

(ii) The projected demand is between 600 to 650 units.

The break even point for single machine option (i.e., 400 units) is not feasible because it exceeds the range of volume that can be produced with one machine (i.e., 0 to 300).

Also, the break even point for 3 machines is 700 units which is more than the upper limit of projected demand of 600 to 650 units and hence not feasible. For 2 machines option the break even volume is 500 units and volume range is 301 to 600.

Hence, the demand of 600 can be met with 2 machines and profit is earned because the production volume of 600 is more than the break even volume of 500. If the manager wants to produce 650 units with 3 machines, there will be loss because the break even volume with three machines is 700 units.

Hence, the manager would choose two machines and produce 600 units.

14. (a) Discuss the topics covered by a project plan.

(b) Explain the different activities included in JIT manufacturing.

Answer:

14. (a) The project plan should cover the following topics:

- **General Project Information:** Points of contact, phone numbers, etc.
- **Project Executive Summary:** Business Need/Problem, Statement of work, Project objectives and approach.
- **Project Scope Statement:** It provides a documented description of the project as to its output, approach and content.
- **Critical Success Factors :** Objectives and commitments.
- **Work Breakdown Structure:** It describes a deliverable-oriented grouping of project elements, which organise and define the total scope of the project.
- **Organisational Breakdown Structure:** It provides an organisation chart that defines the communications channels, responsibilities, and the authority of each participating person/unit.
- **Cost-Benefit Analysis:** It provides the project team with information to make a balanced decision about the costs and benefits, or value, of various economic choices.
- **Resource Plan:** It describes the major resources needed to proceed with the execution of the project.
- **Project Schedule:** It provides the project schedule using a Gantt chart. The schedule must include milestones, task dependencies, task duration, work product delivery dates, quality milestones, configuration management milestones and action items.
- **Risk Plan:** It provides a description of all risks identified for the project and a plan to integrate risk management throughout the project.
- **Procurement Plan:** It identifies those needs for the project, which can be met by purchasing products or services from outside of the agency.
- **Quality Plan:** It provides a Quality Plan that defines the person(s) responsible for project quality assurance, procedures used and resources required to conduct quality assurance.
- **Communications Plan:** It defines the information needs of the project stakeholders and the project team by documenting what, when, and how the information will be distributed.
- **Configuration Management Plan:** It provides the project team with a change in management methodology for identifying and controlling the functional and physical design characteristics of a deliverable.
- **Project Budget Estimate:** It describes cost and budget considerations, including an overview, additional resource requirements, and estimated cost on completion.

14. (b) JIT manufacturing includes many activities :

- (i) Inventory reduction :** JIT is a system for reducing inventory levels at all stages of production viz. raw materials, work-in-progress and finished goods.
- (ii) Quality improvement :** JIT provides a procedure for improving quality both within the firm and outside the firm.
- (iii) Lead time reduction :** With JIT, lead time components such as set-up and move times are significantly reduced.
- (iv) Vendor control/Performance improvement :** JIT gives the buying organisation greater power in buyer-supplier relationship. The firm moves from a situation where multiple suppliers are used to a situation where only one or two suppliers are used for supplying most parts. With fewer suppliers; the buying organisation has more power because it is

Revisionary Test Paper_ Intermediate_Syllabus 2012_Dec 2015

making larger purchases from each vendor. Also, the buying organisation can now impose higher requirements on each supplier in terms of delivery and quality.

- (v) **Continuous Improvement:** In the JIT system, existing problems are corrected and new problems identified in a never-ending; approach to operations management.
- (vi) **Total Preventive Maintenance :** JIT emphasises preventive maintenance to reduce the risk of equipment break-downs which may cause production hold ups and increase in manufacturing cycle time due to delays.
- (vii) **Strategic Gain :** JIT provides the firm's management with a means of developing, implementing and maintaining a sustainable competitive advantage in the market place.

15. (a) A plant manager is considering replacement policy for a new machine. He estimates the following costs (All costs in ₹)

Year	1	2	3	4	5	6
Replacement cost at beginning of year	100	110	125	140	160	190
Salvage value at end of year	60	50	40	25	10	0
Operating costs	25	30	40	50	65	80

Find an optimal replacement policy and corresponding minimum cost.

(b) The data collected in running a machine, the cost of which is ₹ 60,000 are given below:

Year	1	2	3	4	5
Resale value (₹)	42,000	30,000	20,400	14,400	9,650
Cost of Spares (₹)	4,000	4,270	4,880	5,700	6,800
Cost of labour (₹)	14,000	16,000	18,000	21,000	25,000

Determine the optimum period for replacement of the machine.

Answer:

15.(a)

Determination of Optimal Replacement Period

Year (n)	Operating cost M(t)	Cumulative operating cost $\sum M(t)$	Replacement cost at beginning of year (C)	Salvage value at end of year S(t)	Depreciation $C - S(t)$	Total Cost TC_n	Average cost ATC_n
(1)	(2)	(3)	(4)	(5)	(6) = (4) - (5)	(7) = (3) + (6)	(8) = (7) ÷ (1)
1	25	25	100	60	40	65	65.0
2	30	55	110	50	60	115	57.5*
3	40	95	125	40	85	180	60.0
4	50	145	140	25	115	260	65.0
5	65	210	160	10	150	360	72.0
6	80	290	190	0	190	480	80

Revisionary Test Paper_ Intermediate_ Syllabus 2012_ Dec 2015

Since, the average total cost per year is minimum in the second year, the machine should be replaced after 2 years and the corresponding minimum annual cost of replacement is ₹57.5

15. (b) The operating or maintenance costs of machine in successive years is as follows:

Year	1	2	3	4	5
Operating costs (₹)	18,000	20,270	22,880	26,700	31,800

To find the average cost per year of the machine, we prepare the following table:

Table : Determination of Optimal Replacement Period

Year (n)	Operating cost, f(t)	Cumulative operating cost $\sum f(t)$	Resale value, S(t)	Depreciation C — S(t)	Total cost, TC _n	Average cost per year
(1)	(2)	(3)	(4)	(5)	(6) = (3) + (5)	(7) = (6) ÷ (1)
1	18,000	18,000	42,000	18,000	36,000	36,000.0
2	20,270	38,270	30,000	30,000	68,270	34,135.0
3	22,880	61,150	20,400	39,600	100,750	33,583.3
4	26,700	87,850	14,400	45,600	133,450	33,362.5*
5	31,800	119,650	9,650	50,350	170,000	34,000.0

The above table shows that the average cost is minimum during the fourth year. Hence, the machine should be replaced at the end of fourth year.

16. (a) List the advantages of KAIZEN.

(b) List the principles of Total Quality Control.

(c) State Deming's 14 points for quality management.

Answer:

16. (a) Advantages of KAIZEN

The KAIZEN gives freedom to the employees. It does not specify what changes are to be made or how many of them are to be made. Improvements can be in any discipline and in any field of human activity related to the productivity. These decisions are left to the individuals. This leads to obvious advantages as follows:

- The first and foremost benefit of KAIZEN is that it brings about changes in attitude among employees towards improvements of their routine work. Hence it increases the productivity and a new work culture is created in the organisation.
- Once the culture is transformed, the way gets cleared for introducing other productivity improvement systems like JIT, KANBAN etc. obviously leading to productivity improvement.
- KAIZEN system reduces resistance to change.
- Ownership of work improves in KAIZEN environment. It is the inner voice of the employees that drives them to make the improvements, rather than the orders given down through the hierarchy.

16. (b) Total Quality Control (TQC) is an effective system for integrating quality development, quality maintenance and quality improvement efforts of various groups in an organisations.

Principles of Total Quality Control (TQC)

1. Top management policies - Zero defects, continuous improvement etc;
2. Quality control training for everyone;
3. Quality at product/service design stage;
4. Quality materials from suppliers;
5. Quality control in production (SQC);
6. Quality-control in distribution, installation and use;

16. (c) Deming's 14 Points for Quality Management

1. Create constancy of purpose for continual improvement of product/services.
2. Adopt the new policy for economic stability.
3. Cease dependency on inspection to achieve quality.
4. End the practice of awarding business on price tag alone.
5. Improve constantly and forever the system of production and service.
6. Institute training on the job.
7. Adopt and institute modern method of supervision and leadership.
8. Drive out fear. (Fear of failure, fear of change etc).
9. Breakdown barriers between departments and individuals.
10. Eliminate the use of slogans, posters and exhortations.
11. Eliminate work standards and numerical quotas.
12. Remove barriers that rob the hourly worker of the right to pride in workmanship.
13. Institute a vigorous program of education and retraining.
14. Define top management's permanent commitment to ever improving quality and productivity.

17. (a) List the common pitfalls in Benchmarking.

(b) State the objectives of Maintenance Management.

Answer:

17. (a) Common Pitfalls in Benchmarking

- Lack of management commitment and involvement.
- Not applied to critical areas first.
- Inadequate resources.
- No line organisation involvement.
- Too many subjects; scope not well defined.
- Too many performance measures.
- Critical success factors and performance drivers not understood or identified.

- Potential partners ignored: Internal organisations, Industry leaders, or friendly competitors.
- Poorly designed Questionnaires.
- Inappropriate data : Inconsistent data.
- Analysis paralysis, excess precision.
- Communication of findings without recommendations for projects to close gaps.
- Management resistance to change.
- No repeat Benchmarking.
- No Benchmarking report/documentation.

17. (b) Objectives of Maintenance Management

The following are some of the objectives of Maintenance Management:

1. Minimizing the loss of productive time because of equipment failure (i.e., minimizing idle time of equipment due to break down).
2. Minimizing the repair time and repair cost.
3. Minimizing the loss due to production stoppages.
4. Efficient use of maintenance personnel and equipments.
5. Prolonging the life of capital assets by minimizing the rate of wear and tear.
6. To keep all productive assets in good working condition.
7. To maximize efficiency and economy in production through optimum use of facilities.
8. To minimize accidents through regular inspection and repair of safety devices.
9. To minimize the total maintenance cost which includes the cost of repair, cost of preventive maintenance and inventory carrying costs due to spare parts inventory.
10. To improve the quality of products and to improve productivity.

18. (a) Identify the information that should be collected before scheduling maintenance activities.

18. (b) A repairman is to be hired by a company to repair machines that breakdown at an average rate of 3/hour. Breakdown occurs randomly (Poisson distribution) over time. Non-productive time on any machine is considered to cost the company ₹20 per hour. The management has narrowed down the choice to 2 repairmen; one 'slow but cheap' and other 'fast but expensive'. The 'slow but cheap' repairman has a rate of ₹5 per hour and he will service breakdown machines at an average rate of 4/hour. The 'fast but expensive' repairman has a rate of ₹7 per hour and he will service breakdown machines at an average rate of 6/hour. Which repairman should the company hire? Assume exponential repair time for both repairmen.

Answer:

18.(a) The following information should be collected before scheduling maintenance activities:

- (i) Manpower (maintenance crew) available.
- (ii) Pending maintenance work (in terms of man hours backlog).

Revisionary Test Paper_ Intermediate_ Syllabus 2012_ Dec 2015

- (iii) Availability of machine or equipment for preventive maintenance service.
- (iv) Availability of proper tools, handling equipments, consumables, spare parts etc.
- (v) Availability of special maintenance equipments if any, special fixtures and tools, cranes, etc.
- (vi) Whether additional manpower is available at outside sources to be hired when needed.
- (vii) When to start the maintenance work and when it should be completed.
- (viii) Previous maintenance history records or charts.

18. (b)

	'Slow but cheap' repairman	'Fast but expensive' repairman
μ = rate of service	4/ hour	6/hour
Labour rate	₹ 5/hour	₹ 7/hour

In the given situation, breakdown rate = λ = 3 machines per hour

(i) For 'slow but cheap' repairman :

Average (expected) number of breakdowns in the system:

$$L_s = \frac{\lambda}{\mu - \lambda} = \frac{3}{4 - 3} = 3 \text{ machines}$$

Cost of idle machine hours = $3 \times 1 \times ₹20 = ₹60$

Total charges = (Wages + Cost of idle machines) per hour

$$= ₹5 + ₹60 = ₹65$$

(ii) For 'Fast but Expensive' repairman:

Average (expected) number of breakdowns in the system:

$$L_s = \frac{\lambda}{\mu - \lambda} = \frac{3}{6 - 3} = 1 \text{ machine}$$

Cost of idle machine hours = $1 \times 1 \times ₹20 = ₹20$

Total charges = (Wages + cost of idle machine) per hour

$$= ₹7 + ₹20 = ₹17$$

Decision. When total cost of two workmen is taken into consideration, it will be economical to hire 'fast but expensive' repairman.

SECTION B – INFORMATION SYSTEMS

19. Explain the following terms in 2-3 sentences.

- (a) Probabilistic System
- (b) CASE Tools
- (c) Modularity
- (d) Non-programmed decisions
- (e) Black box testing
- (f) Query compiler

(g) **Computer Network**

(h) **Key pair**

Answer:

19.

- (a) **Probabilistic System:** The probabilistic system can be described in terms of probable behavior, but, a certain degree of error is always attached to the prediction. Where a set of instructions given to a human who, for a variety of reasons, may not follow the instructions exactly as given. Forecasting is also a Probabilistic System.
- (b) **CASE Tools:** CASE (Computer-Aided-Software Engineering) refers to the automation of anything that humans do to develop systems and support virtually all phases of traditional system development process. These can be used to create internally requirements specifications with graphic generators and using of specifications languages. The various CASE tools are menu generator, screen generator, report generator and code generator.
- (c) **Modularity:** A module is a manageable unit containing data and instructions to perform a well-defined task. Modularity is measured by two parameters: **Cohesion** and **Coupling**. Cohesion refers to the manner in which elements within a module are linked. Coupling is a measure of the interconnection between modules. In a good modular design, cohesion will be high and coupling will be low.
- (d) Decisions which are unstructured, complex is known as non-programmed decisions. In other words, decisions which are not automated are non-programmed decisions. For example, new product line, capital budgeting etc. Non-programmed decision making has no pre established decision procedure.
- (e) The test designer selects valid and invalid inputs and determines the correct output. If a module performs a function which is not supposed to, the black box test does not identify it as it is not concerned with the internal structure. Thus in black box testing, it has no relation with the internal functioning of a system.
- (f) **The query compiler** handles high-level queries that are entered interactively. It parses, analyzes and compiles or interprets a query by creating database access code and then generates calls to the run-time processor for executing the code.
- (g) **Computer Network:** The interconnection of one or more, computers through
- (i) The use of satellite, microwave, terrestrial line or other communication media and
 - (ii) Terminals or a complex consisting of two or more interconnected computers whether or not the interconnection is continuously maintained.
- (h) "**Key pair**", in an asymmetric crypto system, means a private key and its mathematically related public key, which are so related that the public key can verify a digital signature created by the private key.

20. (a) **Describe the general characteristics of an Information System.**

(b) **Discuss the main reasons for failure of system development objectives.**

Answer:

20. (a) **Characteristics of an Information System :**

The following are the general characteristics of an Information System :

- (i) **Specific objective:** The information system should have some specific objective. An Information System in highly scientific research centre will have an objective to accumulate data from different activities, display of some information instantly for controlling activities and so on. In a business environment, the objective will be sharing information from different functional areas and smooth flow of information for management decision making.
- (ii) **Structured:** An information system should have a definite structure with all modules of sub-systems. The structure depends on the sub-modules, their interactions and integration requirements, operational procedure to be followed and the solution sets. The structure of the information system refers to diagrammatic representation of the system showing sub-systems, their inter-relation and the procedure to be followed to fulfill the process requirements.
- (iii) **Components:** The sub-systems are the components. The sub-systems should be distinguishable among themselves but have well-defined relation among. For example, a Sales system may be sub-systems like Invoicing, Delivery Monitoring, and Sales Proceeds Collection system. The inter-link between these systems must be well defined.
- (iv) **Integrated:** An Information System should be designed in such a fashion that proper integration among sub-systems are taken care to establish correct linkage and generate meaningful information. An information in isolation may not be that meaningful but its usage is improved if it is integrated with information of other closely related issues. For example, Sales information of a region becomes more meaningful if other information like previous period sales, sales in other regions, sales of competitive products are also combined in the information set.
- (v) **Life-Cycle:** An Information system will have its own life-cycle. The duration of life-cycle varies from the system to system. An information system has the similar stages of life-cycle as seen in any other system. Every information system will have distinctly different phases - Initial, Growth, Maturity and Decline.
- (vi) **Behaviour:** A system has its own set of reaction and outcome depending on the environment. A well managed business information system behaves nicely with its users by satisfying them with correct and timely information. The design of the system plays a good role in setting its behaviour pattern.
- (vii) **Self-regulatory:** An Information System which may have different sub-systems interacting with the each other in a desired fashion to be operative smoothly and in the process they regulate themselves. This is what is self-regulatory nature of the system. A payroll system involves three activities – first, maintaining attendance of employees, second, pay calculation and third pay disbursement. If the target date for pay disbursement is last date of a month, the second adjusts its start time accordingly and the first one is also regulated in such a fashion that it can provide input to the second in time.

20. (b) Why organizations fail to achieve their systems development objectives. Some of the major reasons are as follows :

- There is a lack of user participation in the development effort.
- Due to lack of senior management support and involvement in information systems development.
- Personnel are not as familiar with the new technology.
- Systems developers often lack sufficient education background and they are under-trained development staff.

Revisory Test Paper_ Intermediate_ Syllabus 2012_ Dec 2015

- When personnel perceive that the project will result in personnel cutbacks, they always resist to change new technology.
- Inadequate Testing before installation is also a major reason for which organizations fail to achieve their system development objectives.

21. (a) Describe the Preliminary Investigation in relation to SDLC.

(b) List the various fact finding techniques which are used by the system analyst for determining the needs/requirements of an organization.

Answer:

21 (a) The Preliminary Investigation

The basic objective of preliminary investigation is to outline the necessity of SDLC. It also analyse in terms of productivity gains, cost savings, and Intangible benefits like improvement in morale of employees.

The steps involved in the preliminary investigation phase are as follows:

- (i) Identification of Problem
- (ii) Identification of objective
- (iii) Delineation of scope
- (iv) Feasibility study

The following issues are typically answered in the Feasibility Study :

- (i) Whether the existing system can rectify the situation without a major modification?
- (ii) What is the time frame for which the solution is required?
- (iii) What will be the approximate cost to develop the system?
- (iv) Whether the vendor product offers a solution to the problem?

21. (b) Fact finding Techniques

Various fact-finding techniques, which are used by the system analyst for determining the needs/ requirements of an organization are briefly discussed below :

- (i) Documents:** Analysts collect the hierarchy of users and manager responsibilities, job descriptions for the people who work with the current system, procedure manuals, program codes for the applications associated with the current system to understand the existing system.
- (ii) Questionnaires:** Users and managers are asked to complete questionnaire about the problems with the existing system and requirement of the new system. Using questionnaires, a large amount of data can be collected fastly.
- (iii) Interviews:** Users and managers may also be interviewed to extract information in depth.
- (iv) Observation:** Observation plays a key role in requirement analysis. Only by observing how users react to prototypes of a new system, the system can be successfully developed.

22. (a) State the major categories of flowchart and discuss the benefits of using flowchart.

(b) Write a note on Data Dictionary

- (c) Discuss the important factors which should be considered by the system analyst while designing user outputs.

Answer:

22. (a) Flowcharts are divided into four major categories:

- **Document flowchart** - showing a document- flow through systems.
- **Data flowchart** - showing data flows in a system.
- **System flowchart** - showing controls at a physical or resource level.
- **Program flowchart** - showing the controls in a program in a system.

Benefits of Flowchart

- **Communication:** Flowcharts are better way of communicating the logic of a system and easily understandable.
- **Effective analysis:** With the help of flowchart, problem can be analyzed in more effective way.
- **Proper documentation:** Program flowcharts serve as a good program documentation.
- **Efficient Coding:** The flowcharts act as a guide during the systems analysis and program development phase.
- **Proper Debugging:** The flowchart helps in debugging process.
- **Efficient Program Maintenance:** The maintenance of operating program becomes easy with the help of flowchart. It helps the programmer to put efforts more efficiently on that part.

22. (b) Data Dictionary: Each computer record of a data dictionary contains information about a single data item used in a business information system. The information in each record of a Data Dictionary may include the following:

- (i) Codes describing the data item's length, data type and range.
- (ii) Identity of the source documents used to create the data.
- (iii) Names of the computer files storing the data item.
- (iv) Identity of individuals/programs permitted to access the data item.
- (v) Identity of programs/individuals not permitted to access the data item.
- (vi) Names of the computer programs that modify the data item.

For an Auditor, A data dictionary can also help to establish an audit trail because it can identify the input sources of data items, the computer programs that modify particular data items, and the managerial reports on which data items are output. For the accountants, a data dictionary can also be used to plan the flow of transaction data through the system.

22. (c) Important factors which should be considered while designing the user outputs:

These are the important factors which should be considered by the system analyst while designing user outputs.

- (i) **Content:** Only the required information should be included in various outputs because too much content can cause managers to waste time in selecting the information that they need. For example -the contents of a weekly report of a sales manager might consist of sales persons and the amount of each product sold by each sales persons.

- (ii) **Form:** Content can be presented in various forms-quantitative, non-quantitative, text, graphics, video and audio many managers prefer summary information in chart form such as pie chart, line chart, bar chart.
- (iii) **Output volume:** It is better to use high-speed printer which are fast in case the volume is heavy.
- (iv) **Timeliness:** Some outputs are required on a regular, periodic basis - perhaps daily, weekly, monthly, at the end of a quarter or annually.
- (v) **Media:** A variety of output media are available in the market are- video display, microfilm, magnetic tape/disk and voice output.
- (vi) **Format:** The manner in which data are physically arranged is referred to as format.

23. (a) Discuss the factors contributing to evaluation and validation process of vendor's proposals.
- (b) Describe the different categories of System Maintenance.
- (c) Write a note on Operation Manuals.

Answer:

23. (a) Once the proposals are received from various vendors for the system, it is the responsibility of the IT Incharge or the committee to select the best product relevant to the requirements/needs of the organization. In order to facilitate the process, following are the factors contributing to evaluation and validation process of vendors' proposals:

- (i) **Performance Rating of the proposed system in relation to its cost:** In this approach, the vendors are provided with the sample data and the task is performed by each vendor. Subsequently representatives of the organization examine the outputs for accuracy, consistency as well as processing efficiency, so, operational efficiency is judged.
- (ii) **Cost Benefits of the proposed system:** In this process, the cost benefit analysis is performed in relation to the performance benefits against the Total Cost of Operations.
- (iii) **Maintainability of the proposed system:** It refers to the flexibility and customization scope inbuilt in the proposed system for effective use in the organization. If the changes occurring due to the federal tax laws and statutory legal requirements, it should be analysed that whether it can be incorporated in the package easily or not.
- (iv) **Compatibility with Existing Systems:** The proposed system has to be operated in integration with other existing systems in the organization so that it forms a part of the Integrated Enterprise System.
 - **Vendor Support :** Support of vendors must be provided at the time of training, implementation, testing and back-up systems.

23. (b) System maintenance involves modifying reports, adding new reports, changing calculations to update system.

Maintenance can be categorized in the following two ways :

- (1) **Scheduled maintenance:** Scheduled maintenance is anticipated .For example, the implementation of a new inventory coding scheme can be planned in advance. The system should be evaluated periodically to ensure that it is operating properly and is still workable for the organization.
- (2) **Rescue maintenance:** Rescue maintenance refers to previously undetected malfunctions or such sudden changes that were not anticipated but require

immediate solution. Rescue maintenance is unplanned. Thus a system that is properly developed and tested should have few occasions of rescue maintenance.

As System increase and expand, systems maintenance places increasing demands on programmers time.

Some other maintenance which can be done are :

- (i) **Corrective maintenance:** The need for corrective maintenance is usually initiated by bug reports drawn up by the end users.
- (ii) **Adaptive maintenance:** Adaptive maintenance consists of adapting software to changes in the environment, such as change in business rule, government policies,
- (iii) **Perfective maintenance:** Perfective maintenance mainly deals with accommodating to new or changed user requirements and concerns functional enhancements to the system and activities to increase the system's performance or to enhance its user interface.

23. (c) Operation Manuals : A user's guide, also commonly known as an Operation Manual, is a document intended to give assistance to people using a particular system.

The section of an operation manual often include the following:

- A cover page, a title page and copyright page;
- A preface, containing details of related documents and information on how to navigate the user guide;
- A contents page;
- A guide on how to use at least the main functions of the system;
- A troubleshooting section detailing possible errors or problems that may occur, along with how to fix them;
- A FAQ (Frequently Asked Questions);

24. (a) Describe the different End Users.

(b) 'Redundancy in storing the same data multiple times leads to several problems.'
— Discuss.

Answer:

24. (a) End Users

End users are the people whose jobs require access to the database for querying, updating, and generating reports; the database primarily exists for their use. There are several categories of end users:

- **Casual end users** occasionally access the database, but they may need different information each time. They use a sophisticated database query language to specify their requests and are typically middle- or high-level managers or other occasional browsers.
- **Naive or parametric end users** make up a sizable portion of database end users; Their main job function revolves around constantly querying and updating the database, using standard types of queries and updates—called **canned transactions**—that have been carefully programmed and tested. The tasks that such users perform are varied:
 - ❖ Bank tellers check account balances and post withdrawals and deposits.
 - ❖ Reservation clerks for airlines, hotels, and car rental companies check availability for a given request and make reservations.

❖ Clerks at receiving stations for courier mail enter package identifications via bar codes and descriptive information through buttons to update a central database of received and in-transit packages.

- **Sophisticated end users** include engineers, scientists, business analysts, and others who thoroughly familiarize themselves with the facilities of the DBMS so as to implement their applications to meet their complex requirements.
- **Stand-alone users** maintain personal databases by using ready-made program packages that provide easy-to-use menu- or graphics-based interfaces. An example is the user of a tax package that stores a variety of personal financial data for tax purposes.

24. (b) Redundancy in storing the same data multiple times leads to several problems. First, there is the need to perform a single logical update—such as entering data on a new student—multiple times: once for each file where student data is recorded. This leads to duplication of effort. Second, storage space is wasted when the same data is stored repeatedly, and this problem may be serious for large databases. Third, files that represent the same data may become inconsistent. This may happen because an update is applied to some of the files but not to others.

25. (a) Describe the user-friendly interfaces provided by a DBMS.

(b) Explain the terms union operator and intersection operator in relation to RDBMS.

Answer:

25. (a) User-friendly interfaces provided by a DBMS may include the following:

Menu-Based Interfaces for Browsing- These interfaces present the user with lists of options, called **menus**, that lead the user through the formulation of a request. Menus do away with the need to memorize the specific commands and syntax of a query language; rather, the query is composed step by step by picking options from a menu that is displayed by the system. Pull-down menus are becoming a very popular technique in window-based user interfaces. They are often used in **browsing interfaces**, which allow a user to look through the contents of a database in an exploratory and unstructured manner.

Forms-Based Interfaces- Forms-based interface displays a **form** to each user. Users can fill out all of the form entries to insert new data, or they fill out only certain entries, in which case the DBMS will retrieve matching data for the remaining entries. Forms are usually designed and programmed for naive users as interfaces to canned transactions. Many DBMSs have **forms specification languages**, special languages that help programmers specify such forms. Some systems have utilities that define a form by letting the end user interactively construct a sample form on the screen.

Graphical User Interfaces- A graphical interface (GUI) typically displays a schema to the user in diagrammatic form. The user can then specify a query by manipulating the diagram. In many cases, GUIs utilize both menus and forms. Most GUIs use a **pointing device**, such as a mouse, to pick certain parts of the displayed schema diagram.

Natural Language Interfaces- These interfaces accept requests written in English or some other language and attempt to “understand” them. A natural language interface usually has its own “schema,” which is similar to the database conceptual schema. The natural language interface refers to the words in its schema, as well as to a set of standard words, to interpret the request. If the interpretation is successful, the interface generates a high-level query corresponding to the natural language request and submits it to the DBMS for processing; otherwise, a dialogue is started with the user to clarify the request.

Interfaces for Parametric Users- Parametric users, such as bank tellers, often have a small set of operations that they must perform repeatedly. Systems analysts and programmers design and implement a special interface for a known class of naive users. Usually, a small set of abbreviated commands is included, with the goal of minimizing the number of keystrokes required for each request. For example, function keys in a terminal can be programmed to initiate the various commands. This allows the parametric user to proceed with a minimal number of keystrokes.

Interfaces for the DBA- Most database systems contain privileged commands that can be used only by the DBA's staff. These include commands for creating accounts, setting system parameters, granting account authorization, changing a schema, and reorganizing the storage structures of a database.

- 25. (b) Union :** The union operator is denoted by the word UNION or the symbol \cup and it acts on two relations to generate a new relation containing all tuples of the relations except the duplicate ones. This implies that the new relation will have tuples which will belong to either the first relation or the second or both.

Thus the result of this operation, denoted by $R \cup S$, is a relation what includes all tuples those are either in R or in S or in R and S. duplicate tuples are eliminated.

Intersection: The intersection operator is denoted by the word INTERESECT or the symbol \cap and it acts on two relations to generate another relation consisting of only the common tuples between the two.

The result of this operation, denoted by $R \cap S$ includes all tuples that are in both R and S.

- 26. (a) List the objectives of MIS.**

- (b) Describe Top Down Approach and Bottom up Approach used for developing Management Information System.**

Answer:

- 26. (a) Objectives of MIS**

- To provide the managers at all levels with timely and accurate information for control of business activities
- To highlight the critical factors in the operation of the business for appropriate decision making
- To develop a systematic and regular process of communication within the organization on performance in different functional areas
- To use the tools and techniques available under the system for programmed decision making
- To provide best services to customers
- To gain competitive advantage
- To provide information support for business planning for future

- 26. (b) Top Down Approach:** Top Down Approach starts from the identification of information requirements of different activities of the organization by the top management in order to have information support in strategic and tactical decision making and designing the information system accordingly. Top Management provides the guidelines for basic objectives, policies and plan for developing these sub-systems. In other words, this approach designs a model of information flow and same model is used in developing all the sub-systems under the MIS.

Each Sub-systems will have different modules and they are collectively integrated to form a sub-system. The approach of integration is same for all sub-systems. The implementation of different sub-systems is done on the basis of broad guidelines of the top management. Integration of all sub-systems is done at the end to form a comprehensive MIS for the organization. The implementation process is very scientific, systematic and simple.

Bottom Up approach: In the Bottom Up Approach, each sub-systems for different functional areas like Payroll, Sales Management, Production Management, Inventory Control System are developed according to the specifications for each sub-systems on the basis of types of input documents, flow of information and output requirements. There is no common approach for system development. Rather, the sub-systems are developed purely on the basis of control information requirements for each sub-systems and guidelines generated by the manager of the respective functional areas.

The next step in the bottom up approach is to integrate the information of these sub-systems for a comprehensive MIS for the organization. This step is a complicated one in this approach. The data base structure of different systems, flow of information and links among them are to be understood thoroughly to have proper integration. Sometimes intermediate databases are created to collect all relevant information from different sub-systems for integration.

27. (a) Describe On-Line Analytical Processing (OLAP).

(b) List the special features of an Executive Information System.

(c) State the major characteristics of Transaction Processing Systems.

(d) 'Marketing Information System supplies three types of information.' — Discuss.

Answer:

27. (a) On-line Analytical Processing (OLAP)

An OLAP software does the analysis of information from data warehouse. The OLAP applications are widely scattered in divergent application area like Finance Management, Sales Analysis. The real test of an OLAP system is inefficient use of data from databases and computational capability of data to develop model establishing the relationship of various parameters. In fact, it provides the services of 'just-in-time' information.

Though OLAP software are found in widely divergent functional areas, they have three common key features which are:

- Multidimensional views of data
- High analytical ability
- 'Just-in-time' information delivery

Rarely a business model limited a fewer than three dimensions. The common dimensions in business environment are organization, line item, time, product, channel, place etc. OLAP system should have the ability to respond the queries from a manager within a specified time. The OLAP software must provide a rich tool kit of powerful capability of analytical ability.

27. (b) Following are the special features of an Executive Information System:

- It is a specially designed tool to feed executives information need.
- It is an easy - to - use and screen based software.

- It provides the executives the facilities of on-line analysis tools like time series analysis, regression analysis etc.
- It is not limited to internal data only. Access to external sources of data is also provided.
- It provides the facilities to connect to internet.
- Information is presented in summary format.
- It is a comprehensive Information System and work in conjunction with DSS.

27. (c) The Major Characteristics of Transaction Processing System are:

- Large amounts of data are processed.
- The sources of data are mostly internal, and the output is intended mainly for an internal audience.
- The TPS processes information on a regular basis: daily, weekly, monthly, etc.
- Large storage (database) capacity is required.
- High processing speed is needed due to the high volume.
- TPS basically monitors and collects past data.
- Input and output data are structured (i.e., standardized).
- Low computation complexity is usually evident in TPS.
- A high level of accuracy, data integrity, and security is needed.
- High reliability is required.
- Inquiry processing is a must

27. (d) Marketing Information system supplies three types of information.

- Recurrent Information
- Monitoring Information
- Requested Information

Recurrent Information

This is the data that an MIS supplies periodically about the market share of a specific product and customer's awareness of company's brands. The data may be supplied on weekly, monthly or yearly basis.

Monitoring Information

This is the data obtained from the regular scanning of certain sources. Marketing managers may need data related to competition or the industry. It is essential so that marketing managers can be alert and identify potential problems

Requested Information

This information is developed in response to some specific request by the marketing manager. Secondary data or primary data through survey research are collected in response to the specific request. The MIS supplies the requested information for decision making.

28. (a) Explain the terms 'E-Procurement' and 'E-Sales.'

(b) Describe Master Data Management of an ERP System.

Answer:

28. (a) E-Procurement - A typical e-procurement requirement of an organization is depicted below:

- Electronic tendering comprising of tender publication, submission, short listing, evaluation and award. Facility for evaluation of IT/ Service contracts containing Complex evaluation matrix.
- Compliance of agreed quantity Vis-a-Vis called quantity, consolidation of called quantity for obtaining agreed quantity discounts.
- Facility for publication and updating of electronic catalogues by vendors.
- Analytics for spend analysis which is used for strategic decisions, supplier relation management and minimization of maverick buying.
- Facilities for reverse auctions through business to business marketplace.

E-sales enhance value in respect of following business process:

- Reaching the customer quickly and a transparent way through the process of electronic auction.
- Processing customer orders promptly through web storefront applications.
- Checking credentials of the customer.
- Arrange drop shipment where the nearest distributor ships goods.
- Providing facility to customer to check status of order through web.

28. (b) ERP packages contain several modules, such as finance, sales and distribution, materials management, manufacturing and production control, human resources, plant maintenance and quality management. Main characteristics of ERP system is that all its modules function in an integrated manner. Due to integrated nature of functioning, a few master tables are referenced frequently all across the system and databases, and shared by different applications, functional areas and sites. Data incorporated thereon need to be accurate, complete, timely and consistent. The quality of data as inputted in master tables, is a major reason for success or otherwise of an ERP system.

Collection and maintenance of master data

1. Clear cut process and procedure for maintenance of master data.
2. Ownership of data is properly defined.
3. In built workflow and authorization for adding and modifying data.
4. Documentation of the process.
5. Audit trails of master tables are activated and modifications are logged in the system.
6. Proper excel templates or data mapping with legacy system, for initial collection of data.

29. (a) Discuss the scope of Information Technology Act, 2000.

(b) List the advantages of E-commerce.

Answer:

29. (a) Scope of the Information Technology Act: This Act is applicable to whole of India, unless otherwise provided in the Act. It also applies to any offence or contravention there under committed outside India by any person.

Different provisions of this Act came into force on the different dates as notified by the Central Government.

The Act shall not be applicable to the following:

- a negotiable instrument as defined in Section 13 of the Negotiable Instruments Act, 1881;
- a Power of Attorney as defined in Section 1A of the Powers-of-Attorney Act, 1882;
- a trust as defined in Section 3 of the Indian Trusts Act, 1882;
- a will as defined in Section (h) of Section 2 of the Indian Succession Act, 1925 including any other testamentary disposition by whatever name called;
- any contract for the sale or conveyance of immovable property or any interest in such property;
- Any such class of documents or transactions as may be notified by the Central Government in the Official Gazette.

29. (b) E-commerce has Several Advantages:

- **Businesses without the barriers of time or distance:** E-commerce plays very important role in allowing people to carry out businesses without the barriers of time or distance. One can log on to the Internet at any time, whether day or night and purchase or sell anything at his desires.
- **Lower cost-of-sale:** As there is no human interaction (wholeseller, retailer etc.) during the on-line electronic purchase order process, therefore, the direct cost-of-sale for an order taken from a web site is lower than through traditional means. Further, electronic selling also eliminates processing errors, and is also more convenient for the visitor.
- **Cheapest means of doing business:** Another important benefit of E-commerce is that as compare to paper based commerce it is the cheapest means of doing business.
- **Advantages to buyer:** From the buyer's perspective also E-commerce offers a lot of advantages.
 - (a) Reduction in buyer's sorting out time.
 - (b) Better buyer decisions;
 - (c) Less time is spent in resolving invoice and order discrepancies.
 - (d) Increased opportunities for buying alternative products.
- **Less delivery time, labour cost etc.:** A significant benefit of E-commerce is that it helps to reduce the delivery time, labour cost and the cost incurred in the following areas:
 - (a) Document preparation;
 - (b) Error detection and correction;
 - (c) Mail preparation;
 - (d) Communication;
 - (e) Data entry;
 - (f) Overtime for completing the work; and
 - (g) Supervision expenses

- **Price fixation:** The day-to-day pressures of the marketplace have played their part in reducing the opportunities for companies to invest in improving their competitive position. A mature market, increased competitions have all reduced the amount of money available to invest. If the selling price cannot be increased and the manufactured cost cannot be decreased then the difference can be in the way the business is carried out. E-commerce has provided the solution by decimating the costs, which are incurred.

30. (a) Write a note on Commerce Net.

(b) State the duties of Certifying Authority according to Section 30 of the Information Technology Act, 2000.

Answer:

30. (a) Commerce Net

Commerce Net is a consortium of companies which is promoting the use of internet for E-commerce. Sponsored by Silicon Valley vendors and US government agencies, it was launched in 1994 with the aim of creating infrastructure for business-to-business transactions on the internet.

Today, it has over 120 members and helps companies to streamline their procurement and development cycles by performing transactions online, overcome impediments to E-commerce by making new interfaces, security mechanisms and indexing tools.

30. (b) According to Section 30 of the Information Technology Act, 2000, Certifying Authority shall follow certain procedures in respect of Digital Signatures as given below:

- Make use of hardware, software and procedures that are secure from intrusion and misuse.
- Provide a reasonable level of reliability in its services, which are reasonably suited to the performance of intended functions.
- Adhere to security procedures to ensure that the secrecy and privacy of the digital signatures are assured and
- Observe such other standards, as specified by the regulation.

Every Certifying Authority shall ensure that every person employed by him complies with the provisions of the Act, or rules, regulations or orders made thereunder.

A Certifying Authority must display its licence at a conspicuous place of the premises in which it carries on its business. A Certifying Authority whose licence is suspended or revoked shall immediately surrender the licence to the Controller.

Every Certifying Authority shall display its Digital Signature Certificate, which contains the public key corresponding to the private key used by that Certifying Authority and other relevant facts.