

2022

July

VOL: 7, NO.: 7,

TOLL FREE 18003450092 / 1800110910



**CMA Student**  
**E - Bulletin**

**FINAL**

**FOLLOW US ON**

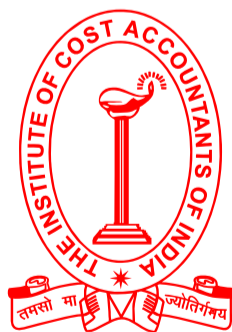

**THE INSTITUTE OF COST ACCOUNTANTS OF INDIA**

(Statutory Body under an Act of Parliament)

[www.icmai.in](http://www.icmai.in)

Headquarters: CMA Bhawan, 12 Sudder Street, Kolkata - 700016

Ph: 091-33-2252 1031/34/35/1602/1492

Delhi Office: CMA Bhawan, 3 Institutional Area, Lodhi Road, New Delhi - 110003

Ph: 091-11-24666100

Behind every successful business decision, there is always a **CMA**

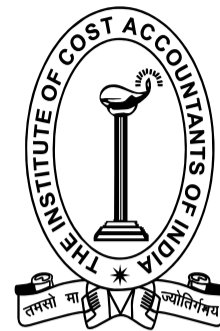

# CONTENTS

Knowledge Update -	1
Group : III Paper 13: Corporate Laws & Compliance (CLC) -	2
Group: III Paper 14: Strategic Financial Management (SFM) -	5
Group: III Paper 15: Strategic Cost Management - Decision Making (SCMD) -	8
Group: III Paper 16: Direct Tax Laws and International Taxation (DTI) -	13
Group: IV Paper 17: Corporate Financial Reporting (CFR) -	16
Group: IV Paper 18: Indirect Tax Laws & Practice (ITP) -	22
Group: IV Paper 19: Cost & Management Audit (CMAD) -	26
Group: IV Paper 20: Strategic Performance Management and Business Valuation (SPBV) -	29
Practical Advice -	33
Submissions -	34
Message from the Directorate of Studies -	35
Few Snapshots -	36



# KNOWLEDGE Update

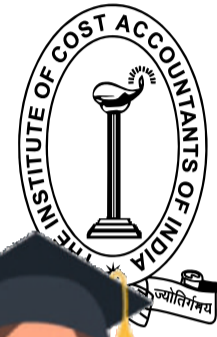

In this section of e-bulletin we shall have a series of discussion on each of these chapters to provide a meaningful assistance to the students in preparing themselves for the examination at the short end and equip them with sufficient knowledge to deal with real life complications at the long end.



GROUP: iii, PAPER: 13

# CORPORATE LAWS & COMPLIANCE (CLC)

Shri Subrata Kr. Roy  
Company Secretary & Consultant  
He can be reached at:  
[subrataoffice@rediffmail.com](mailto:subrataoffice@rediffmail.com)

## Your Preparation Quick Takes

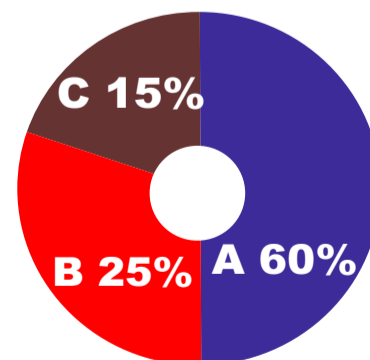

### Syllabus Structure

A Companies Act **60%**

B Other Corporate Laws **25%**

C Corporate Governance **15%**



**Learning Objectives:**

Read the Study Material minutely.

- For details or if you don't understand Study Material or the section is important to identify the topic, then refer to Bare Act, otherwise reference to Bare Act is not necessary. For Company Law, book by Avtar Singh is recommended. For other laws Institute Study Material is sufficient.
- The words used in any of the texts as mentioned above should be understood by immediate reference to the Dictionary.
- The main points coming out in any of the provisions should be either underlined or written in separate copy which has to be repeated again and again.
- Theoretical knowledge should be adequate and clear before solving practical problems.
- Don't write wrong English. It changes the meaning and therefore answer may be wrong even when the student's conception is clear. Also don't make spelling mistakes.

## Company Capital

### COMPANY CAPITAL- AN OVERVIEW

Any business including a company will have two sources of capital, i.e. own capital (equity) and loan capital. (long term credit), there can be a financial instrument which is converted from loan to equity. Normally equity is not converted into loan, though there is no legal bar.

#### Shares and Debentures

Shares and debentures are the main source of long term source of capital. Companies Act does not consider working capital as capital and therefore the restrictions relating to treatment of capital do not apply to working capital.

#### Types of Share Capital:

There are various terms used in connection with the share capital of the company. They are as follows:

#### Authorized / Registered / Nominal Capital-

This is the Maximum Capital which the company can raise in its life time. This is mentioned in the Memorandum of the Association of the Company. It is also called Registered Capital or Nominal Capital. Authorised capital may be increased by altering the Memorandum of Association.

#### Issued Capital-

This is the part of the Authorised Capital which is issued to the public for Subscription i.e. any person to whom the invitation is made may subscribe for shares. Private limited companies can issue shares to its existing shareholders by way of rights issue or by way of giving them bonus shares or it can issue securities through private placements. The act of creating new issued shares is called issuance, allocation or allotment. After allotment, a subscriber becomes a shareholder. The number of issued shares is a subset of the total authorized shares.

#### Subscribed Capital-

The issued Capital may not be fully subscribed (applied for) by the investor/public. Subscribed Capital is that part of issued Capital for which applications are received from the public. In case applications are for more than the issued capital we call it oversubscription. If it is less, it is called under subscription.

#### Paid-up Capital-

The part of subscribed capital which have been paid to the company by the investors i.e. the Company may require 50% of the value of shares while making subscriptions. In such case 50% of the value received by the company shall be the paid up capital.

For any company, paid-up capital is important as many provisions of the Act and Rules require various types of compliances based on paid-up capital.

#### Types of shares

##### Shares defined

A share is defined as unit of ownership that represents an equal proportion of a company's capital. It entitles its holder (the shareholder) to an equal claim on the company's profits and an equal obligation for the company's debts and losses.

Two major types of shares are (1) **ordinary (equity) shares (common stock)**, which entitle the shareholder to share in the earnings of the company as and when they occur, and to vote at the company's general meetings of shareholders, and (2) **preference shares (preferred stock)** which entitle the shareholder to a fixed predetermined rate of dividend but generally do not have voting rights. The dividend is payable only when the Company makes adequate profits. This kind of shares is preferred for both payment of dividend and the payment of principal (redemption) on liquidation. Otherwise also preference shares have to be redeemed within 20 years (30 years in case of infrastructure companies)

They get reference in

- (i) payment of dividend; paid before dividend are paid to equity shareholders
- (ii) redemption of capital in case of liquidation in share of assets

#### Types of preference share

- (i) **Cumulative and non cumulative:** here if dividend is not paid or paid less than agreed, it has to be paid in subsequent years when company makes profit. No such benefit is possible in case of non cumulative preference shares.

(ii) **Participating and non participating:** In case of participating preference shares, if company makes substantial profit, the preference shareholders are given more dividend than agreed. No such benefit is possible in case of non participating preference shares.

(iii) **Optionally redeemable preference shares:** In this case, though there will be a maximum period of redemption, the holder may opt before that date

**Share with differential voting rights:** here there can be shares rights of one class of equity share is different from the other class of equity shares.

**Non voting shares:** there is no voting rights for these kind of

### Debentures

A debenture is a type of long term debt instrument which acknowledges debt.

Debentures are backed only by the general creditworthiness and reputation of the issuer. Both corporations and governments frequently issue this type of bond to secure capital. Debentures may be secured or unsecured.

#### Types of Debenture:

The major types of debentures are redeemable, irredeemable, convertible, non-convertible, fully, partly, secured, unsecured, fixed, floating rate, zero coupon, deep discount. Following are the various types of debentures vis-a-vis their basis of classification:

#### Redeemable and Irredeemable (Perpetual) Debentures

Redeemable debentures carry a specific date of redemption on the certificate. The company is legally bound to repay the principal amount to the debenture holders on that date. On the other hand, irredeemable debentures, also known as perpetual debentures, do not carry any date of redemption. This means that there is no specific time of redemption of these debentures. They are redeemed either on the liquidation of the company or when the company chooses to pay them off to reduce their liability by issues a due notice to the debenture holders beforehand.

#### Convertible and Non-Convertible Debentures

Convertible debenture holders have to convert their holdings into equity shares. The rate of conversion and the period after which the conversion will take effect are declared in the terms and conditions of the agreement of debentures at the time of issue. On the contrary, non-convertible debentures are simple debentures which will continue to be debentures till redemption. However, if option is given to the investor to convert or not to convert the debenture into shares, this kind of debenture is called optionally convertible debentures.

#### Fully and Partly Convertible Debentures

Convertible Debentures are further classified into two - Fully and Partly Convertible. Fully convertible debentures are completely converted into equity whereas the partly convertible debentures have two parts. Convertible part is converted into equity as per agreed rate of exchange based on terms of issue. Non-convertible part remains as redeemable debenture which is repaid after the expiry of the agreed period.

#### Secured and Unsecured Debentures

When the debenture is secured by the charge on some asset or set of assets it is known as secured or mortgage debenture and when it is issued solely on the credibility of the issuer is known as the naked or unsecured debenture. In case of unsecured debenture, the Debenture holder is like any other unsecured creditor. In case of secured debenture, there is a security created by the company on its assets. In case of issue of debenture on private placement basis, the security can be decided by the issuer company and the investor. Public issue of debentures have to be secured, if the maturity period is more than 18 months. In such case, a debenture trustee is appointed, to whom the security is mortgaged with a condition that if the company fails to repay interest or principal, the debenture trustee shall have right to sale off the property and satisfy the claims of debenture holders both interest and principal.

#### Fixed and Floating Rate Debentures

Fixed rate debentures have fixed interest rate over the life of the debentures.

The floating rate debentures have the floating rate of interest which is dependent on some benchmark rate and goes on fluctuating depending on market conditions.

#### Zero Coupon Debentures

Zero coupon debentures do not carry any coupon rate (interest) or we can say that there is zero coupon rate. The debenture holder will not get any interest on these types of debentures. In such case a warranty is issued with a debenture which may have entitlement to get a share at discount. This compensates the interest foregone. However, zero coupon rate debentures may be issued at discount and are normally called "discounted bonds". If the maturity period is long it is called "deep discount bond".



GROUP: iii, PAPER: 14

# STRATEGIC FINANCIAL MANAGEMENT (SFM)

Dr. Swapan Sarkar,  
Assistant Professor  
Department of Commerce,  
University of Calcutta  
He can be reached at:  
[swapansarkar22@gmail.com](mailto:swapansarkar22@gmail.com)

## Your Preparation Quick Takes

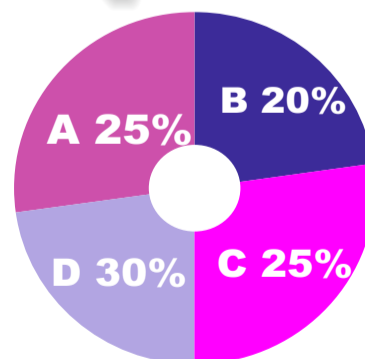

### Syllabus Structure

- A Investment Decisions 25%
- B Financial Markets and Institutions 20%
- C Security Analysis and Portfolio Management 25%
- D Financial Risk Management 30%



**Learning objectives:**

After studying this section on Strategic Financial Management, you will be able to:

- understand the direct and indirect quotations
- know the European terms and American terms

## Section C & Study Note 8: Security Analysis and Portfolio Management

### B. Industry Analysis (Continued from previous issue...)

#### III. Structural Analysis

The nature of the competitive conditions existing in an industry can provide useful information in assessing its future. The intensity of competition in an industry determines that industry's profitability. Professor Micheal Porter in his famous book on 'Competitive Strategy' has undertaken a detailed analysis of the forces that shape the competitive structure in an industry.

Competition in an industry continually works to drive down the rate of return on invested capital towards the competitive floor rate of return, or the return that would be earned by the economist's 'perfectly competitive' industry. This competitive floor, or 'free market' return, is approximated by the yield on long-term government securities adjusted upward by the risk of capital loss. Investors will not tolerate returns below this rate in the long run because of their alternative of investing in other industries, and firms habitually earning less than this return will eventually go out of business. The presence of rates of return higher than the adjusted free market return serves to stimulate the inflow of capital into an industry either through new entry or through additional investment by existing competitors. The strength of the competitive forces in an industry determines the degree to which this inflow of investment occurs and derives the return to the free market level, and thus the ability of firms to sustain above average returns.

The five competitive forces - entry, threat of substitution, bargaining power of buyers, bargaining power of suppliers, and rivalry among current competitors reflect the fact that competition in an industry goes well beyond the established players. Customers, suppliers, substitutes, and potential entrants are all 'competitors' to firms in the industry and may be more or less prominent depending on a particular circumstance. Competition in this broader sense might be termed extended rivalry.

#### A. Threat of Entry

New entrants to an industry bring new capacity, the desire to gain market share, and often substantial resources. Prices can be bid down or incumbent costs inflated as a result, reducing profitability. Companies diversifying through acquisition into the industry from other markets often use their resources to cause a shake-up. This acquisition into an industry with intent to build market position should probably be viewed as entry even though no entirely new entity is created.

The threat of entry into an industry depends on the barriers to entry that are present, coupled with the reaction from existing competitors that the entrant can expect. If barriers are high and/or the newcomer can expect share retaliation from entrenched competitors, the threat of entry is low.

Following are the major sources of barriers to entry:

- Economies of scale:** Economies of scale refer to decline in unit cost of a product (or operation or function that goes into producing a product) as the absolute volume per period increases. Economies of scale deter entry by forcing the entrant to come in at large scale and risk strong reaction from existing firms or come in at a small scale and accept a cost disadvantage, both undesirable options.
- Product differentiation:** Product differentiation means that established firms have brand identification and customer loyalties, which stem from past advertising, customer service, product difference, or simply being first into the industry. Differentiation creates a barrier to entry by forcing entrants to spend heavily to overcome existing customer loyalties.
- Capital Requirements:** The need to invest large financial resources in order to compete creates a barrier to entry, particularly if the capital is required for risky or unrecoverable upfront advertising or Research and Development (R&D).
- Switching Costs:** A barrier to entry is created by the presence of switching costs, that is, one-time costs facing the buyer of switching from one supplier's product to another's. If these switching costs are high, then new entrants must offer a major improvement in cost or performance in order for the buyer to switch from an incumbent.
- Access To Distribution Channels:** A barrier to entry can be created by the new entrant's need to secure distribution for its product; to the extent the logical distribution channels accept its product through price breaks, co-operative advertising allowances, and the like, there will be a reduction in the profits. The more limited the wholesale or retail channels for a product are and the more existing competitors have these tied up, obviously, the tougher the entry into the industry will be.
- Cost Disadvantage Independent of Scale:** Established firms may have cost advantages not replicable by potential entrants, no matter what their size and attained economies of scale. The most critical advantages are factors are proprietary product technology, access to raw material, favorable locations, government assistance and learning curve effect.
- Government Policy:** Another major source of entry barriers is government policy. Government can limit or even foreclose entry into industries with such controls as licensing requirements and limits on access to raw materials. More subtle government restrictions on entry can stem from control such as air and water pollution standards and products safety and efficacy regulations. Government policy in such areas certainly has direct social benefits, but it often has secondary consequences for entry which are unrecognized.
- Expected Retaliation:** The potential entrant's expectations about the reaction of existing competitors also will influence the threat



of entry. If existing competitors are expected to respond forcefully to make the entrant's stay in the industry an unpleasant one, then entry may well be deterred.

#### **B. Pressure from Substitute Products**

All firms in an industry are competing, in a broad sense, with industries producing substitute products. Substitutes limit the potential returns of an industry by placing a ceiling on the prices firms in the industry can profitably charge. The more attractive the price performance alternative offered by substitutes, the firmer the lid on industry profits.

Identifying substitute products is a matter of searching for other products that can perform the same function as the product of the industry. Sometimes doing so can be a subtle task, and one which leads the analyst into businesses seemingly far removed from the industry.

#### **C. Bargaining Power of Buyers**

Buyers compete with the industry by forcing down prices, bargaining for higher quality or more services, and playing competitors against each other - all at the expense of industry profitability. The power of each of the industry's important buyer groups depends on a number of characteristics of its market situation and on the relative importance of its purchases from the industry compared with its overall business.

#### **D. Bargaining Power of Suppliers**

Suppliers can exert bargaining power over participants in an industry by threatening to raise prices or reduce the quality of purchased goods and services. Powerful suppliers can thereby squeeze profitability out of an industry unable to recover cost increases in its own prices.

#### **E. Intensity of Rivalry among Existing Competitors**

Rivalry among existing competitors takes the familiar form of jockeying for position - using tactics like price competition, advertising battles, product introductions, and increased customer service or warranties. Rivalry occurs because one or more competitors either feels the pressure or sees the opportunity to improve positions. In most industries, competitive moves by one firm have noticeable effects on its competitors and thus may incite retaliation or efforts to counter the move; that is, firms are mutually dependent. This pattern of action and reaction may or may not leave the initiating firm and the industry as a whole better off. If moves and countermoves escalate, then all firms in the industry may suffer and be worse off than before.

Some forms of competition, notably price competition, are highly unstable and quite likely to leave the entire industry worse off from the standpoint of profitability. Price cuts are quickly and easily matched by rivals, and once matched they lower revenues for all firms unless industry price elasticity of demand is high enough. Advertising battles, on the other hand, may well expand demand or enhance the level of product differentiation in the industry for the benefit of all firms.

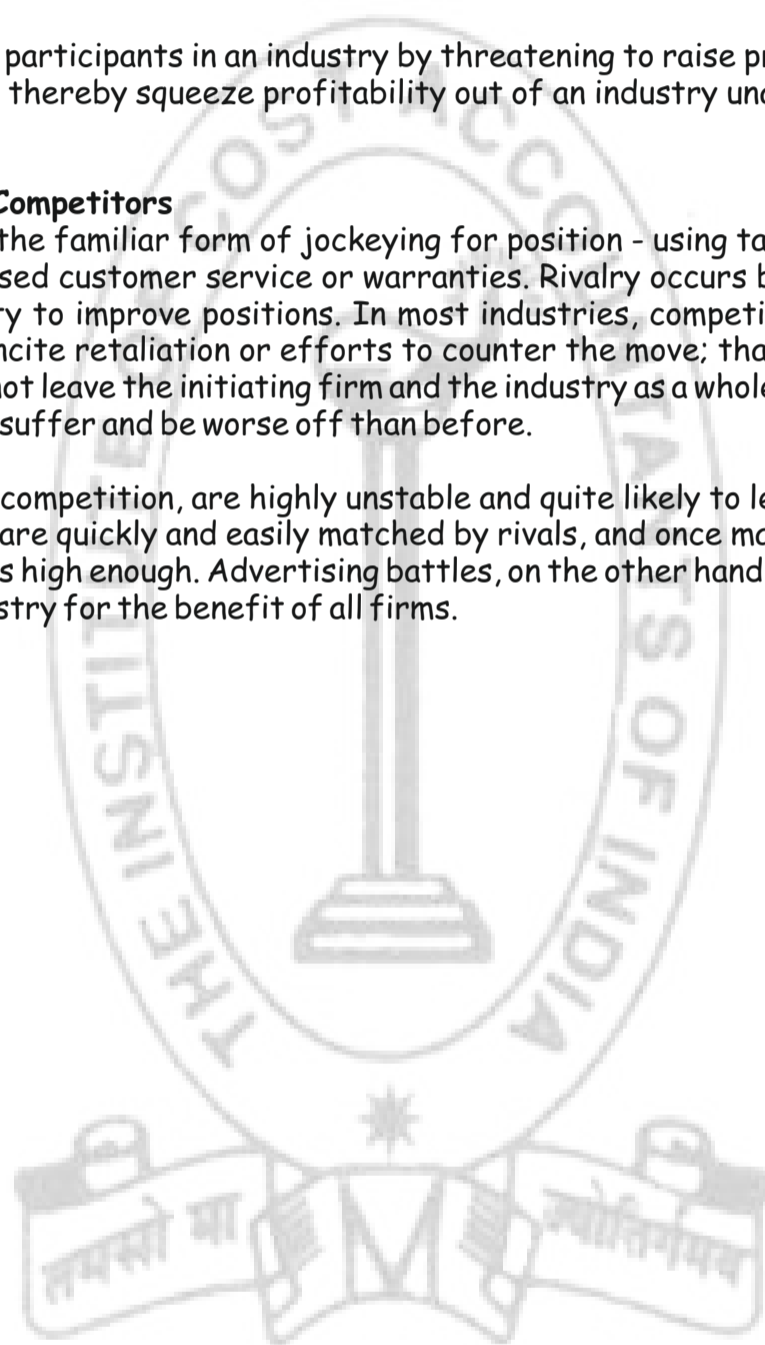



GROUP: iii, PAPER: 15

# STRATEGIC

COST MANAGEMENT-  
DECISION MAKING

(SCMD)

CMA (Dr.) Sreehari Chava  
Cost & Management Consultant,  
Nagpur, Maharashtra,  
He can be reached at:  
[sreeharichava@yahoo.co.in](mailto:sreeharichava@yahoo.co.in)

## Your Preparation Quick Takes

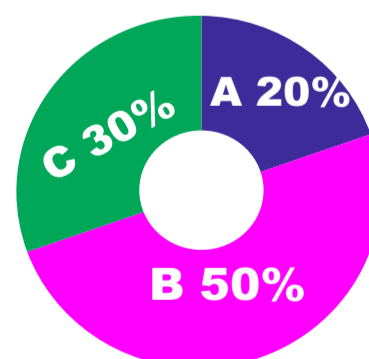

### Syllabus Structure

A Cost Management 20%

B Strategic Cost Management  
Tools and Techniques 50%

C Strategic Cost Management -  
Application of Statistical Techniques  
in Business Decisions 30%

**Learning Objectives:**

The Strategic cost management framework provides a clear plan of attack for addressing costs and decisions that affect them. It helps to get answers on:

- Is there a plan for strategic cost management?
- Have the controlling functions for each significant cost in the organization been identified?
- Are there resources devoted to finding or obtaining new approaches to breaking cost barriers?
- Is cost modelling being used or is there an active effort to develop or buy cost modelling capability?

## Net Work Analysis

**01.00 Concept**

Network analysis is the general name given to PERT and CPM techniques which can be used for planning, management and control of a project. Network is a graphical representation of all the activities and events of a project arranged in a logical and sequential order. In this context, activity is the actual performance of the job which consumes resources like time, human resources, money, material, etc. An event refers to the starting point or completion point of a job. Network analysis enables us to take a systematic quantitative structural approach to the problem of managing a project through to successful completion. Also, since it has a graphical representation, it can be easily understood and used by those with a less technical background.

**02.00 PERT & CPM**

**PERT:** Project Evaluation and Review Techniques (PERT) is a method of analysing the tasks involved in completing a given project, especially the time needed to complete each task, and to identify the minimum time needed to complete the total project. It incorporates uncertainty by making it possible to schedule a project while not knowing precisely the details and durations of all the activities. It is more of an event-oriented technique rather than start- and completion-oriented, and is used more in projects where time is the major factor rather than cost. It is applied to very large-scale, one-time, complex, non-routine infrastructure and Research and Development projects.

**CPM:** Critical Path Method (CPM) or Critical Path Analysis (CPA) is a project management tool that helps determination of the minimum time needed to complete a project. The CPM:

- (i) Sets out all the individual activities that make up a larger project.
- (ii) Shows the order in which activities have to be undertaken.
- (iii) Shows which of the activities can be taken up only when the other activities have been completed.
- (iv) Shows which of the activities can be undertaken simultaneously, thereby reducing the overall time taken to complete the whole project.
- (v) Pinpoints the time schedules needed for the specified resources, for example, a crane to be hired for a building site.

PERT and CPM are complementary tools. CPM employs one time estimate and one cost estimate for each activity. PERT may utilize three-time estimates (optimistic, expected, and pessimistic) and no costs for each activity. Although these are distinct differences, the term PERT is applied increasingly to all critical path scheduling.

**03.00 Avenues of Application**

- (i) Construction of Buildings and Complexes
- (ii) Ship building
- (iii) Satellite mission development
- (iv) Installation of a pipe line project
- (v) Research & Development
- (vi) Inventory Planning & Control
- (vii) Traffic flow Control
- (viii) Long Range Planning
- (ix) And so on ...

**04.00 Procedure of drawing a CPM Network**

1. Specify the individual Activities: From the work breakdown structure, a listing can be made of all the activities in the project. This listing can be used as the basis for adding sequence and duration information in the subsequent steps.
2. Determine the Sequence of the Activities: Determine the sequence of performing the activities and arrange them in that order. Some activities are dependent on the completion of the others. A listing of the immediate predecessors of each activity is useful for constructing the network diagram.
3. Draw the Network diagram: Once the activities and their sequencing have been defined, the network diagram can be drawn.
4. Estimate Activity Completion Time: The time required to complete each activity can be estimated using past experience or the estimates of knowledgeable persons. CPM is a deterministic model that does not consider variation in the completion time, so only



one number is used for an activity's time estimate.

5. Identify the Critical Path: The critical path is the longest-duration path through the network. It is the path which does not have any spare (float or slack) time. The significance of the critical path is that the activities that lie on it cannot be delayed without delaying the project. Because of its impact on the entire project, critical path analysis is an important aspect of project planning. The critical path can be identified by determining the four parameters for each activity. The four parameters are Earliest Start, Earliest Finish, Latest Finish and Latest Start.

**05.00 Rules for drawing the network diagrams**

In a network diagram, arrows represent the activities and circles represent the events.

- (i) The tail of an arrow represents the start of an activity and the head represent the completion of the activity.
- (ii) The event numbered 1 denotes the start of the project and is called initial event.
- (iii) Event carrying the highest number in the network denotes the completion of the project and is called terminal event.
- (iv) Each defined activity is represented by one and only arrow in the network.
- (v) Determine which operation must be completed immediately before other can start.
- (vi) Determine which other operation must follow the other given operation.
- (vii) The network should be developed on the basis of logical, analytical and technical dependencies between various activities of the project.

**06.00 Problem for Practice**

**Problem**

A small maintenance project consists of the following twelve jobs whose precedence relations are identified with their node number:

Serial Number	Job (i,j)	Duration (in days)
1	(1,2)	10
2	(1,3)	4
3	(1,4)	6
4	(2,3)	5
5	(2,5)	12
6	(2,6)	9
7	((3,7)	12
8	(4,5)	15
9	(5,6)	6
10	(6,7)	5
11	(6,8)	4
12	(7,8)	7

Required:

- (i) Draw an arrow diagram representing the project.
- (ii) Calculate earliest start, earliest finish, latest start and latest finish times for all the jobs.
- (iii) Find the critical path and project duration.
- (iv) Tabulate slack, total float, free float and independent float.

**Solution**

(Arrow Diagram of the Project)

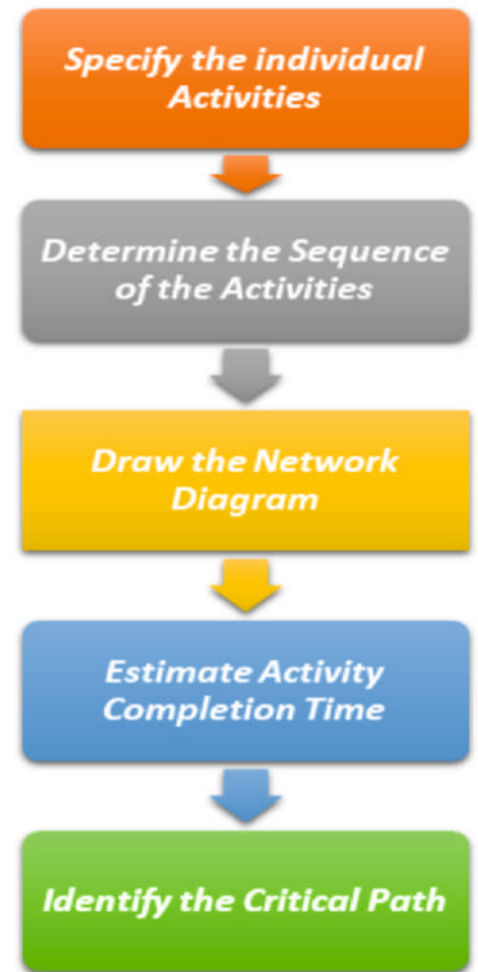
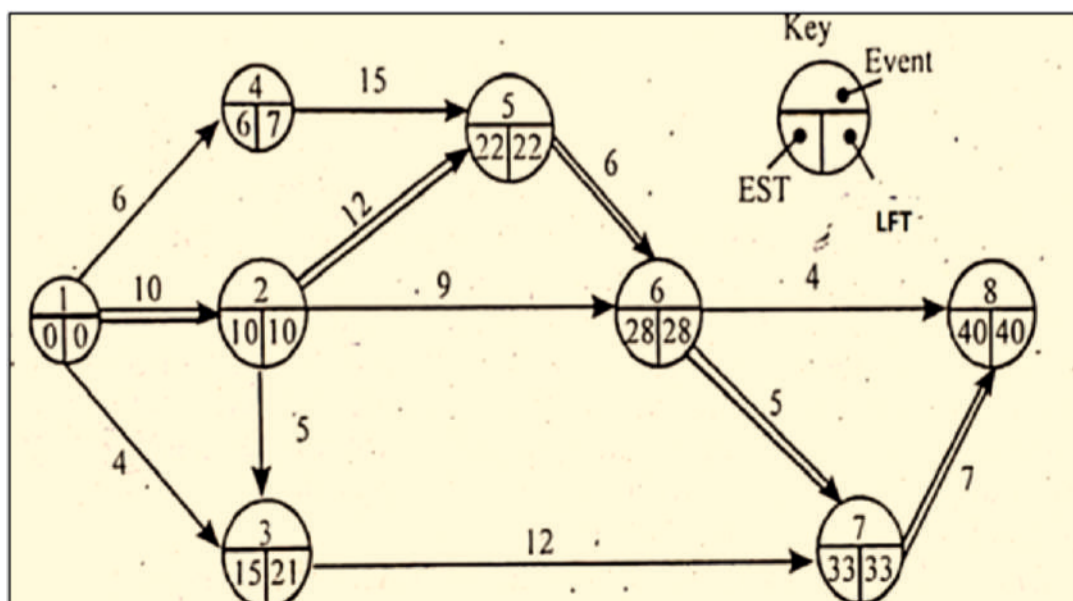



(ii) Statement showing Earliest Start Time (EST), Earliest Finish Time (EFT), Latest Start Time (LST) and Latest Finish Time (LFT) for all jobs

Jobs	Duration in days	Earliest Time		Latest Time	
		Start(EST)	Finish (EFT)	Start (LST)	Finish (LFT)
1-2	10	0	10	0	10
1-3	4	0	4	17	21
1-4	6	0	6	1	7
2-3	5	10	15	16	21
2-5	12	10	22	10	22
2-6	9	10	19	19	28
3-7	12	15	27	21	33
4-5	15	6	21	7	22
5-6	6	22	28	22	28
6-7	5	28	33	28	33
6-8	4	28	32	36	40
7-8	7	33	40	33	40

#### Explanatory Notes

- EST of the activity is the EST of node at the start of activity.  
EFT = (EST + Time duration of the Activity)  
EST and EFT can be determined by means of **Forward Pass**.
- LFT of the activity is the LFT of the node at the end of the activity.  
LST = (LFT - Time duration of the Activity)  
LFT and LST can be determined by means of **Backward Pass**.

(iii) **Critical Path** = 1 → 2 → 5 → 6 → 7 → 8

Project duration = 10 + 12 + 6 + 5 + 7 = 40 days

(Critical Path is depicted through double line arrows. The critical path is the longest path (in time) from Start to Finish. It indicates the minimum time necessary to complete the entire project. Activities that are on Critical Path have zero float.)

(iv) Tabulation of Slack, Total Float, Free Float and Independent Float

Jobs	Duration in days	Slack of event		Total Float (TF)	Free Float (FF)	Independent Float
		at start of activity	at end of activity			
1-2	10	0	0	10-10=0	0-0=0	0-0=0
1-3	4	0	6	21-4=17	17-6=11	11-0=11
1-4	6	0	1	7-6=1	1-1=0	0-0=0
2-3	5	0	6	21-15=6	6-6=0	0-0=0
2-5	12	0	0	22-22=0	0-0=0	0-0=0
2-6	9	0	0	28-19=9	9-0=9	9-0=9
3-7	12	6	0	33-27=6	6-0=6	6-6=0
4-5	15	1	0	22-21=1	1-0=1	1-1=0
5-6	6	0	0	28-28=0	0-0=0	0-0=0
6-7	5	0	0	33-33=0	0-0=0	0-0=0
6-8	4	0	0	40-32=8	8-0=8	8-0=8
7-8	7	0	0	40-40=0	0-0=0	0-0=0

Page14 **Explanatory Notes**

- Slack:** The head (terminal) event slack of an activity in a network is the slack at the head (or terminal point) of an activity. In

other words, head event slack of an activity in a network is the difference between the latest event time and earliest event time at its head (or terminal point or node).

- b. **Total Float:** Total Float is the amount of time that an activity can be delayed from its early start time without delaying the project finish time.

$$\text{Total Float (TF)} = (\text{LFT} - \text{EFT}) \text{ or } (\text{LST} - \text{EST})$$

- c. **Free Float:** Free Float is the amount of time an activity can be delayed without delaying the Early Start of its successor activity.

$$\text{Free Float} = (\text{Total Float} - \text{Slack of event at end of the activity})$$

Free float can also be calculated by subtracting the Early Finish Time of the activity from the Early Start Time of the next activity

- d. **Independent Float:** Independent Float is that portion of the total float within which an activity can be delayed for start without affecting the float of the preceding activities. It is computed for an activity by subtracting the tail event slack from its total float.

$$\text{Independent Float} = (\text{Free Float} - \text{Slack of the event at start of the activity})$$

#### 07.00 Quick Take

PERT and CPM are complementary tools.





GROUP: iii, PAPER: 16

# DIRECT TAX

LAWS AND INTERNATIONAL  
TAXATION (DTI)

CA Vikash Mundhra  
He can be reached at:  
[vikash@taxpointindia.com](mailto:vikash@taxpointindia.com)

## Your Preparation Quick Takes

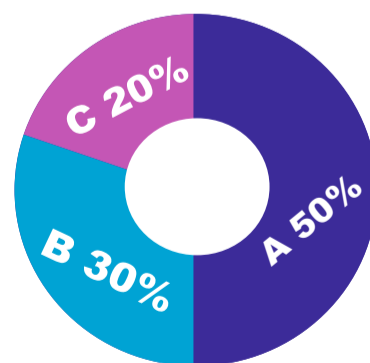

### Syllabus Structure

A Advanced Direct Tax Laws 50%

B International Taxation 30%

C Case Study Analysis 20%

**Learning Objectives:**

- To develop basic idea about the problem of International double taxation
- To get acquainted with the methods of reliefs
- To have acquaintance with the basic provisions of the provisions of the Indian Income-tax Act regarding reliefs for double taxation.

**Thin Capitalization**

A company is typically financed or capitalized through a mixture of debt and equity. The way a company is capitalized often has a significant impact on the amount of profit it reports for tax purposes as the tax legislations of countries typically allow a deduction for interest paid or payable in arriving at the profit for tax purposes while the dividend paid on equity contribution is not deductible. Therefore, the higher the level of debt in a company, and thus the amount of interest it pays, the lower will be its taxable profit. For this reason, debt is often a more tax efficient method of finance than equity. Multinational groups are often able to structure their financing arrangements to maximize these benefits. For this reason, country's tax administrations often introduce rules that place a limit on the amount of interest that can be deducted in computing a company's profit for tax purposes. Such rules are designed to counter cross-border shifting of profit through excessive interest payments, and thus aim to protect a country's tax base.

Under the initiative of the G-20 countries, the Organization for Economic Co-operation and Development (OECD) in its Base Erosion and Profit Shifting (BEPS) project had taken up the issue of base erosion and profit shifting by way of excess interest deductions by the MNEs in Action plan 4. The OECD has recommended several measures in its final report to address this issue.

In view of the above, sec. 94B was inserted in line with the recommendations of OECD BEPS Action Plan 4, to provide that interest expenses claimed by an entity to its associated enterprises shall be restricted to 30% of its earnings before interest, taxes, depreciation and amortization (EBITDA) or interest paid or payable to associated enterprise, whichever is less.

The provisions of sec. 94B are enumerated here-in-below:

**Applicable to**

Indian company, or a permanent establishment of a foreign company in India, being the borrower

- *Permanent establishment* includes a fixed place of business through which the business of the enterprise is wholly or partly carried on.

**Conditions**

- The borrower has debt issued by a non-resident, being an associated enterprise of such borrower.
  - *Debt* means any loan, financial instrument, finance lease, financial derivative, or any arrangement that gives rise to interest, discounts or other finance charges that are deductible in the computation of income chargeable under the head "Profits and gains of business or profession";
- He incurs any expenditure by way of interest or of similar nature exceeding ₹ 1 crore;
- Such expenditure is deductible in computing income chargeable under the head "Profits and gains of business or profession"

**Effect**

If all the aforesaid conditions are satisfied then, excess interest shall not be deductible in computation of income under the said head.

✳ *Excess interest* means lower of the following:

- An amount of total interest paid or payable in excess of 30% of earnings before interest, taxes, depreciation and amortisation (EBITDA) of the borrower in the previous year; or
- Interest paid or payable to associated enterprises for that previous year

**Taxpoint**

✳ *Guarantee*: Where the debt is issued by a lender which is not associated but an associated enterprise either provides an implicit or explicit guarantee to such lender or deposits a corresponding and matching amount of funds with the lender, such debt shall be deemed to have been issued by an associated enterprise.

✳ *Exception*:

The provision of sec. 94B is not applicable:

- to an Indian company or a permanent establishment of a foreign company which is engaged in the business of banking or insurance; or
  - to interest paid in respect of a debt issued by a lender which is a permanent establishment in India of a non-resident, being a person engaged in the business of banking
- ✳ *Carry forward*: Where for any assessment year, the interest expenditure is not wholly deducted against income under the head "Profits and gains of business or profession", so much of the interest expenditure as has not been so deducted, shall be carried



forward to the following assessment year(s), and it shall be allowed as a deduction against the profits and gains, if any, of any business or profession carried on by it and assessable for that assessment year to the extent of maximum allowable interest expenditure.

- \* **Maximum carried forward:** No interest expenditure shall be carried forward for more than 8 assessment years immediately succeeding the assessment year for which the excess interest expenditure was first computed.

#### Example

Computation of interest expenses disallowed u/s 94B:

₹ in crore

Particulars	Case 1	Case 2	Case 3
EBIDTA of the Indian Borrower	100	100	100
30% of the above [A]	30	30	30
Interest payable to associated enterprise [B]	35	Nil	15
Interest payable to non-associated enterprise [C]	Nil	35	20
Total Interest expense incurred [D = B + C]	35	35	35
Total interest expenses incurred in excess of 30% of EBITDA [E = D - A]	5	5	5
Interest payable to associated enterprise [B]	35	Nil	15
Excess interest [lower of (E) and (B)] being disallowed u/s 94B	5	Nil	5





GROUP: iv, PAPER: 17  
**CORPORATE**  
FINANCIAL REPORTING  
(CFR)

Dr. Ananda Mohan Pal  
Professor,  
Department of Business  
Management,  
The University of Calcutta,  
He can be reached at:  
apal59@gmail.com

# Your Preparation Quick Takes

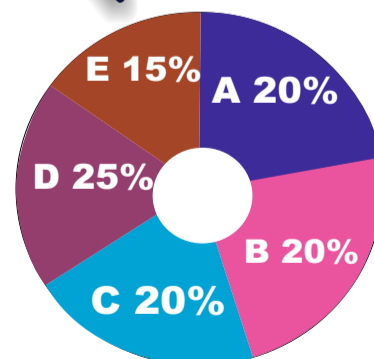

### Syllabus Structure

- A GAAP and Accounting Standards 20%
- B Accounting if Business Comminations & Restructuring 20%
- C Consolidated Financial Statements 20%
- D Developments in Financial Reporting 25%
- E Government Accounting in India 15%

**Learning Objectives:**

After studying the present section of Corporate Financial Reporting you will be able to:

- Learn how to highlight the achievements of a company to its investors, creditors, bankers, public, employees, regulatory bodies and Government on a periodic basis
- To convey future based strategic roadmap for the company.

## Corporate Financial Reporting

### General Instructions for Preparation of Balance Sheet

In this issue I am presenting some important parts of general instructions for preparation of balance sheet as provided in Division II of Schedule III of the Companies Act 2013 as amended in 2021 and applicable from 01-04-2021

1. An entity shall classify an asset as current when-
  - (a) it expects to realise the asset, or intends to sell or consume it, in its normal operating cycle;
  - (b) it holds the asset primarily for the purpose of trading;
  - (c) it expects to realise the asset within twelve months after the reporting period; or
  - (d) the asset is cash or a cash equivalent unless the asset is restricted from being exchanged or used to settle a liability for at least twelve months after the reporting period.

An entity shall classify all other assets as non-current.

2. The operating cycle of an entity is the time between the acquisition of assets for processing and their realisation in cash or cash equivalents. When the entity's normal operating cycle is not clearly identifiable, it is assumed to be twelve months.

3. An entity shall classify a liability as current when-
  - (a) it expects to settle the liability in its normal operating cycle;
  - (b) it holds the liability primarily for the purpose of trading;
  - (c) the liability is due to be settled within twelve months after the reporting period; or
  - (d) it does not have an unconditional right to defer settlement of the liability for at least twelve months after the reporting period.

Terms of a liability that could, at the option of the counterparty, result in its settlement by the issue of equity instruments do not affect its classification.

An entity shall classify all other liabilities as non-current.

4. A receivable shall be classified as a 'trade receivable' if it is in respect of the amount due on account of goods sold or services rendered in the normal course of business.

5. A payable shall be classified as a 'trade payable' if it is in respect of the amount due on account of goods purchased or services received in the normal course of business.

6. A company shall disclose the following in the Notes:

#### A. Non-Current Assets

##### I. Property, Plant and Equipment:

- (i) Classification shall be given as per the format:
- (ii) Assets under lease shall be separately specified under each class of assets.
- (iii) A reconciliation of the gross and net carrying amounts of each class of assets at the beginning and end of the reporting period showing additions, disposals, acquisitions through business combinations, amount of change due to revaluation (if change is 10% or more in the aggregate of the net carrying value of each class of Property, Plant and Equipment) and other adjustments and the related depreciation and impairment losses or reversals shall be disclosed separately.

##### II. Investments:

- (i) Investments shall be classified as
  - (a) Investments in Equity Instruments;
  - (b) Investments in Preference Shares;
  - (c) Investments in Government or trust securities;

- (d) Investments in debentures or bonds;
- (e) Investments in Mutual Funds;
- (f) Investments in partnership firms; or
- (g) Other investments (specify nature).

Under each classification, details shall be given of names of the bodies corporate that are-

- (i) subsidiaries,
- (ii) associates,
- (iii) joint ventures.

III. Trade Receivables:

#### B. Current Assets

I. Inventories:

Inventories shall be classified as-

- (a) Raw materials;
- (b) Work-in-progress;
- (c) Finished goods;
- (d) Stock-in-trade (in respect of goods acquired for trading);
- (e) stores and spares;
- (f) Loose tools; and
- (g) Others (specify nature).
- (ii) Goods-in-transit shall be disclosed under the relevant sub-head of inventories.
- (iii) Mode of valuation shall be stated.

II. Trade Receivables:

(i) Trade Receivables shall be sub-classified as:

- (a) Trade Receivables considered good - Secured;
- (b) Trade Receivables considered good - Unsecured;
- (c) Trade Receivables which have significant increase in Credit Risk; and
- (d) Trade Receivables - credit impaired.

(ii) Allowance for bad and doubtful debts shall be disclosed under the relevant heads separately,

(iii) For trade receivables outstanding, following ageing schedule shall be given:

Trade Receivables ageing schedule

(Amount in Rs.)

Particulars	Outstanding for following periods from due date of payment#					Total
	Less than 6 months	6 months -1 year	1-2 years	2-3 years	More than 3 years	
(i) undisputed Trade receivables - considered good						
(ii) Undisputed Trade Receivables - which have significant increase in credit risk						
(iii) Undisputed Trade Receivables - credit impaired						
(iv) Disputed Trade Receivables-considered good						
(v) Disputed Trade Receivables - which have significant increase in credit risk						
(vi) Disputed Trade Receivables - credit impaired						

III. Cash and cash equivalents:

Cash and cash equivalents shall be classified as-



- a. Balances with Banks (of the nature of cash and cash equivalents);
- b. Cheques, drafts on hand;
- c. Cash on hand; and
- d. Others (specify nature).

**D. Equity****I. Equity Share Capital:**

For each class of equity share capital:

- (a) the number and amount of shares authorised;
- (b) the number of shares issued, subscribed and fully paid, and subscribed but not fully paid;
- (c) par value per share;
- (d) a reconciliation of the number of shares outstanding at the beginning and at the end of the period;
- (e) the rights, preferences and restrictions attaching to each class of shares including restrictions on the distribution of dividends and the repayment of capital;
- (f) shares in respect of each class in the company held by its holding company or its ultimate holding company including shares held by subsidiaries or associates of the holding company or the ultimate holding company In aggregate;
- (g) shares in the company held by each shareholder holding more than five per cent. shares specifying the number of shares held;
- (h) shares reserved for issue under options and contracts or commitments for the sale of shares or disinvestment, including the terms and amounts;
- (i) for the period of five years immediately preceding the date at which the Balance Sheet is prepared-
  - aggregate number and class of shares allotted as fully paid up pursuant to contract without payment being received in cash;
  - aggregate number and class of shares allotted as fully paid up by way of bonus shares; and
  - aggregate number and class of shares bought back;
- (j) terms of any securities convertible into equity shares issued along with the earliest date of conversion in descending order starting from the farthest such date;
- (k) calls unpaid (showing aggregate value of calls unpaid by directors and officers)
- (l) forfeited shares (amount originally paid up)
- (m) A company shall disclose Shareholding of Promoters\* as under:

Shares held by promoters at the end of the year				% Change during the year***
S. No	Promoter name	No. of Shares**	%of total shares	
Total				

\*Promoter here means promoter as defined in the Companies Act, 2013.

\*\* Details shall be given separately for each class of shares

\*\*\* percentage change shall be computed with respect to the number at the beginning of the year or if issued during the year for the first time then with respect to the date of issue.

**II. Other Equity**

'Other Reserves' shall be classified in the notes as-

- (a) Capital Redemption Reserve;
  - (b) Debenture Redemption Reserve;
  - (c) Share Options Outstanding Account; and
  - (d) others- (specify the nature and purpose of each reserve and the amount in respect thereof);
- (Additions and deductions since last balance sheet to be shown under each of the specified heads)
- (ii) Retained Earnings represents surplus i.e balance of the relevant column in the Statement of Changes in Equity;
  - (iii) A reserve specifically represented by earmarked investments shall disclose the fact that it is so represented; disclose the fact that it is so represented;
  - (iv) Debit balance of Statement of Profit and Loss shall be shown as a negative figure under the head 'retained earnings'. Similarly, the balance of 'Other Equity', after adjusting negative balance of retained earnings, if any, shall be shown under the head 'Other Equity' even if the resulting figure is in the negative; and
  - (v) Under the sub-head 'Other Equity', disclosure shall be made for the nature and amount of each item.

**E. Non-Current Liabilities****I. Borrowings:**

(i) borrowings shall be classified as-

(a) Bonds or debentures

(b) Term loans

(I) from banks

(II) from other Parties

(c) Deferred payment liabilities

(d) Deposits

(e) Loans from related Parties

(g) Liability component of compound financial instruments

(h) Other loans (specify nature);

(ii) borrowings shall further be sub-classified as secured and unsecured. Nature of security shall be specified separately in each case

**II. Provisions:**

The amounts shall be classified as-

(a) Provision for employee benefits; and

(b) Others (specify nature).

**IV. Other current liabilities:**

(a) Advances; and

(b) Others (specify nature).

**F. Current Liabilities****Trade payables due for payment**

The following ageing schedule shall be given for Trade payables due for payment:-

Trade Payables ageing schedule

(Amount in Rs.)

Particulars	Outstanding for following periods from due date of payment#				Total
	Less than 1 year	1-2 years	2-3 years	More than 3 years	
(I ) SME					
(ii) Others					
(iii) Disputed dues - MSME					

- **Title deeds of Immovable Properties not held in name of the Company**

The company shall provide the details of all the immovable properties whose title deeds are not held in the name of the company in the given format.

- **Wilful Defaulter**

Where a company is a declared wilful defaulter by any bank or financial Institution or other lender, specified details shall be given.

(a) Date of declaration as willful defaulter,

(b) Details of defaults (amount and nature of defaults)

\* wilful defaulter" here means a person or an issuer who or which is categorized as a willful defaulter by any bank or financial institution (as defined under the Companies Act, 2013) or consortium thereof, in accordance with the guidelines on wilful defaulters issued by the Reserve Bank of India.

- **Following Ratios to be disclosed: -**

(a) Current Ratio,

(b) Debt-Equity Ratio,

© Debt Service Coverage Ratio,

- (d) Return on Equity Ratio
- (e) Inventory turnover ratio
- (f) Trade Receivables turnover ratio
- (g) Trade payables turnover ratio
- (h) Net capital turnover ratio,
- (I) net profit ratio,
- (j) Return on Capital employed,
- (k) Return on investment.

The company shall explain the items included in numerator and denominator for computing the above ratios. Further explanation shall be provided for any change in the ratio by more than 25% as compared to the preceding year.

We shall take up General instructions for preparation of Statement of Profit and Loss in the next issue.





GROUP: iv, PAPER: 18

# INDIRECT TAX LAWS & PRACTICE (ITP)

CMA Rana Ghosh  
Chief Executive Officer,  
Institution of Estate Managers  
& Appraisers  
He can be reached at:  
[ranaham@rediffmail.com](mailto:ranaham@rediffmail.com)

## Your Preparation Quick Takes

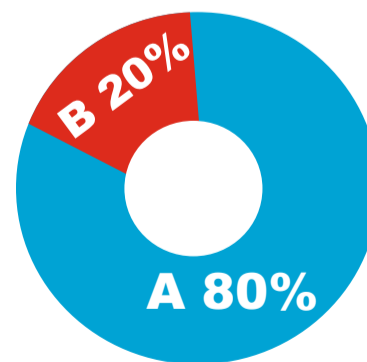

### Syllabus Structure

A Advanced Indirect Tax  
and Practice **80%**

B Tax Practice and Procedures **20%**



## Learning Objectives -

Through the following MCQ, students can refresh themselves about

- TRN number
- GST - taxability
- Supply of goods & services
- Aggregate turnover
- Taxable supply
- Due date for GST payment
- Time of supply

## INDIRECT TAX

Choose the correct option from the followings -

1. Under GST Law Temporary Reference Number is a unique reference number consist of
  - (a) 12 digit
  - (b) 14 digit
  - (c) 15 digit
  - (d) 16 digit
2. Which one of the following statement is incorrect
  - (a) GST is a destination-based consumption tax
  - (b) GST offers comprehensive and continuous chain of tax credit
  - (c) GST where burden borne by everybody involve in supply chain
  - (d) GST brings uniform tax structure all over India
3. GST, being a consumption-based tax - in this view which of the statement is correct -
  - (a) The recipient State will receive the GST amount
  - (b) The supplier State should not get any GST
  - (c) The recipient state and supplier state will share GST 50:50
  - (d) The supplier state and Central Government will share GST 50:50
4. The chairperson of the GST Council is
  - (a) President of India
  - (b) Prime Minister of India
  - (c) Union Finance Minister
  - (d) Any of the State Finance Minister
5. Which of the following will be considered as supply
  - (a) Services by Member of Parliament and others
  - (b) Actionable claim other than lottery, betting and gambling
  - (c) Supply of warehoused goods to any person before clearance for home consumption
  - (d) import of services for a consideration whether or not in the course or furtherance of business
6. Which of the following will not be considered as supply
  - (a) rental
  - (b) lease
  - (c) donation
  - (d) disposal
7. Which of the following person is not liable to pay GST
  - (a) Managing Director
  - (b) Executive Director
  - (c) Non Executive Director
  - (d) Nominee Director
8. The supply of external storage battery supplied with UPS would be considered as a
  - (a) Composite supply

- (b) Mixed supply
- (c) Normal supply
- (d) Single supply

9. In which of the following case aggregate turnover will be excluded

- (a) The value of exported goods/services
- (b) Inter-state supplies between distinct persons having same PAN
- (c) Supply on own account and on behalf of principal
- (d) Compensation Cess

10. Intimation of withdrawal from Composition Scheme to be given in

- (a) Form GST CMP-04
- (b) Form GST CMP-04
- (c) Form GST CMP-06
- (d) Form GST CMP-06

11. Which of the following supply will be considered as exempted supply

- (a) Speed Post Service provided by Department of Post to Government
- (b) Express Parcel Post Services by Department of Post provided to a business entity
- (c) Services in relation to an aircraft or a vessel, inside or outside the precincts of a port or an airport
- (d) Transport of goods or passengers

12. In which of the below mentioned case NIL rate of tax will not be applicable

- (a) Ordinary coach
- (b) Rental car
- (c) Metered cab
- (d) E-rickshaws

13. Which of the following is taxable supply

- (a) Rearing of Silkworm and horticulture
- (b) Plantation of tea and coffee
- (c) Processing of Potato chips on jobwork basis
- (d) Renting of Agro-machinery

14. Services by an artist by way of a performance in folk or classical art forms of music or dance or theatre will be taxable if the consideration charged for such performance is not more than

- (a) Rs 50000/-
- (b) Rs 100000/-
- (c) Rs 150000/-
- (d) Rs 200000/-

15. As per GST Act A motor vehicle not equipped with its engine or with its interior fittings will be considered

- (a) Work in progress
- (b) Semi finished vehicle
- (c) Not considered as vehicle
- (d) Complete vehicle

16. Due date for payment of GST for Assessee turnover not exceeds Rs 1.50 crore in the P.Y.

- (a) 18th of the month following the quarter
- (b) 20 days after the end of the calendar month or 7 days after last date of validity period of registration
- (c) 20th of the following month
- (d) 20th of the following month from the end of relevant quarter

17. Which of the following statement is correct in relation to advance received against future supplies of goods

- (a) No GST to be paid
- (b) No GST to be paid if turnover is below Rs 1 crores
- (c) No GST to be paid if turnover is below Rs 1.50 crores
- (d) No GST to be paid if turnover is below Rs 2 crores

18. Time of supply for goods sent on approval will be

- (a) The date on which payment is entered in his books of accounts or the date on which the payment is credited to his bank account whichever is earlier
- (b) The date of issue of invoice or Date of receipt of payment, at the option of the supplier

- (c) Time when each statement is issued or time when each payment is received, whichever is earlier  
(d) Time when it becomes known that supply is taken place or six month from the date of removal, whichever is earlier

**19. In the value of supply under GST**

- (a) TCS would be includible  
(b) TCS would not be includible  
(c) TCS will be dealt separately  
(d) TCS will be add back to total turnover

**20. If the discount is given after supply, and not known at the time of supply - in this context which of statement is correct**

- (a) Discount will be add back to the total supply  
(b) Discount will form part of supply  
(c) Cannot be claimed as deduction from transaction value  
(d) Can be claimed as deduction from transaction value

**ANSWERS**

1	c	6	c	11	a	16	d
2	c	7	b	12	b	17	a
3	a	8	b	13	c	18	d
4	c	9	d	14	c	19	b
5	d	10	a	15	d	20	c

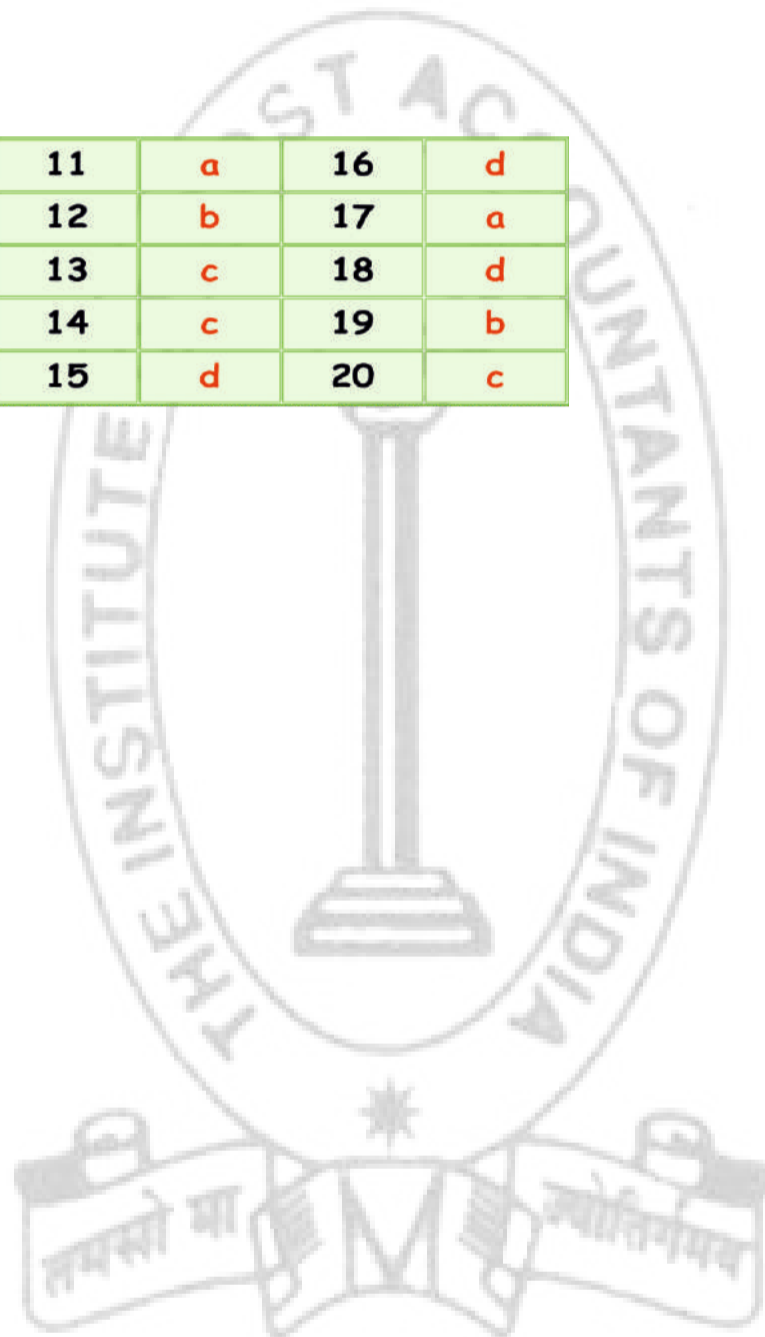



GROUP: iv, PAPER: 19

# COST & MANAGEMENT AUDIT (CMAD)

CMA S S Sonthalia  
Practicing Cost Accountant  
He can be reached at:  
[sonthalia\\_ss@yahoo.co.in](mailto:sonthalia_ss@yahoo.co.in)

## Your Preparation Quick Takes

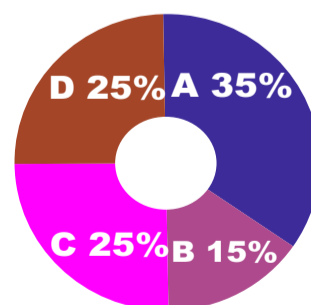

### Syllabus Structure

- A Cost Audit 35%
- B Management Audit 15%
- C Internal Audit, Operational Audit and other related issues 25%
- D Case Study on Performance Analysis 25%



## Learning Objectives:

- To verify the correctness of the cost accounting records.
- To find out whether the principles of cost accountancy have been fully and correctly applied in maintaining cost records.
- To search for the deficiencies in the cost record system of the company.
- To attain efficiency in cost accounting systems and procedures

**COST AND MANAGEMENT AUDIT**

Abridged Profit & Loss Account of M/s XTZ Ltd. a listed manufacturing company for the year ending 31.03.2022 is given below.

Particulars	Amount (Rs. In Lacs)
<b>Income</b> a. Revenue from Operation.	327.36
b. Other income	23.39
<b>Total Income</b>	<b>350.75</b>
<b>Expenses</b> a. Cost of Material Consumed	194.26
b. Change in inventories of finished goods	6.80
c. Employee Benefit Expenses	41.85
d. Finance cost	18.08
e. Depreciation & Amortisation	14.96
f. Other expenses	32.02
<b>Total Expenses</b>	<b>320.02</b>
Profit for the year before Tax	30.73
	-----
	<b>307.9742.78</b>

Profit as per Cost records Rs. 53.84 Lacs. During the course of cost audit, the following issues transactions are observed. Prepare reconciliation statement to find out the difference between profit as per Finance and Cost records with suitable explanation / note wherever necessary.

	Amount (Rs. In Lacs)
<b>Cost of materials includes: -</b>	
Demurrage charges on Raw Materials	2.65
Cost of Material includes prior period adjustment	12.54
Primary Packing Material Cost	18.50
<b>Other income in includes: -</b>	
Provision Written Back	0.80
Liquidated Damage received	1.85
Interest on Security deposit with Electricity Company	0.54
Sale of Scrap	6.35
Interest on Income Tax Refund	0.45
Interest Income from Advance to Supplier	0.78
<b>Employee Cost in includes</b>	
Apprenticeship Training Stipend	0.58
Arrear salary relating to prior period	4.23
Wages paid to Temporary labour	7.28
Free housing and free conveyance	3.72
Recruitment cost	0.86
Special incentive for Covid -19	2.45
<b>Other expenses includes:</b>	
Expenses for Covid-19 Vaccination camp	0.66
Loss on Sale of Machinery	0.27
<b>Change in inventory of Closing Finished goods</b>	
As per Financial Accounts	6.80
As per Cost Accounts	10.42

**Answer**

The reconciliation statement between profit as per Finance and Cost records is worked out below.

Particulars	Amount (Rs. In Lacs)
Profit as per Cost Account	53.84
<b>Add</b>	
<b>Non cost Income considered in Finance accounts</b>	
1. Provision Written Back	0.80
2. Liquidated Damage received	1.85
3. Interest on Security deposit with Electricity Company	0.54
4. Sale of Scrap	3.70
5. Interest on Income Tax Refund	
6. Interest Income from Advance to Supplier	
<b>Sub- Total</b>	0.45
<b>Less - Non Cost Expenses considered on Finance accounts</b>	0.78
	8.12
1. Demurrage charge on Raw material	61.96
2. Cost of Material includes prior period adjustments	
3. Arrear salary relating to prior period	
4. Loss on Sale of Machinery	2.65
4. Special incentive for Covid -19	12.54
6. Expenses for Covid-19 Vaccination camp	4.23
<b>Sub- Total</b>	0.27
	2.45
Add Change in Inventory of FG	0.66
<b>Profit As per Finance Account before tax</b>	22.80
	39.16.
	3.62
	42.78
	=====

**Note.**

1. Primary Packing Material Cost is part of material cost, hence does not need any adjustment.
2. Apprenticeship Training Stipend, Wages paid to Temporary labour, Free housing and free conveyance; Recruitment cost are part of employee's cost, hence does not need any adjustment.



GROUP: iv, PAPER: 20

# STRATEGIC

PERFORMANCE MANAGEMENT  
AND BUSINESS VALUATION  
(SPBV)

Dr. Ashish Kumar Sana  
Professor, Department of Commerce  
University of Calcutta  
He can be reached at:  
[cu.ashis@gmail.com](mailto:cu.ashis@gmail.com)

## Your Preparation Quick Takes

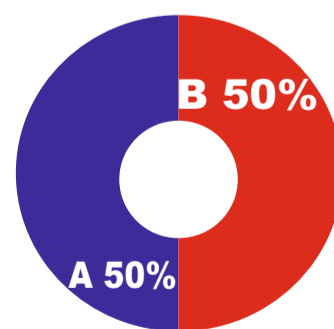

### Syllabus Structure

A Strategic Performance Management 50%  
B Business Valuation 50%

**Learning objectives:**

After studying this section on Strategic Performance Management and Business Valuation, you will be able to:

- understand H Model and Three Stage Growth Model of equity share
- solve the problems on H Model and Three Stage Growth Model of equity share

**Strategic Performance Management and Business Valuation**

(Based on Available Literatures, Study Material, MTP, RTP and Previous End-Terms Questions)

**Short-type questions**

Write True or False:

1. Benchmarking focusses on supply chain management.
2. Economic profit is total revenue minus total cost.
3. The value of a firm's equity is equal to value of the firm less the value of non-equity claims.
4. Intrinsic value of a share decreases after a bonus issue.
5. A positive net profit after taxes always implies that there is an economic value addition to the firm.

Answer Hints:

Question	1	2	3	4	5
Answer	False	True	True	True	False

Multiple Choice Questions:

1. **Charging very high price in the beginning and reducing it gradually is called**
  - (a) Skimming pricing
  - (b) Differential pricing
  - (c) Sealed bid pricing
  - (d) Penetration pricing
2. **The firm is said to be in equilibrium, when it's Marginal Cost (MC) Equals to ----**
  - (a) Total cost
  - (b) Total revenue
  - (c) Marginal Revenue
  - (d) Average Revenue
3. **If the expected rate of return on a stock exceeds the required rate-**
  - (a) The stock is experiencing super normal profit
  - (b) The stock should be sold
  - (c) The company is not probably trying to maximise price per share
  - (d) The stock is a good buy
4. **If a company has a P/E ratio of 20 and a ROE (Return on Equity) of 15% then the Market to Book Value Ratio is-**
  - (a) 3 times
  - (b) 3%
  - (c) Cannot be calculated from the given information
  - (d) None of the above?
5. **X Ltd's share beta factor is 1.40. The risk-free rate of interest on government securities is 9%. The expected rate of return on the company equity shares is 16%. The cost of equity capital based on CAPM is-**
  - (a) 15.8%
  - (b) 16%
  - (c) 18.8%
  - (d) 9%

Answer Hints:



Question	1	2	3	4	5
Answer	a	c	d	a	c

**Example 1**

Shyam Ltd. has announced issue of warrants on 1:1 basis for its equity shareholders. The current price of the stock ₹10 and warrants are convertible at an exercise price of ₹11.71 per share. Warrants are detachable and are trading at ₹3.

Based on the above information, answer the following questions:

(i) What is the minimum price of the warrant?

2 marks

**Answer:**

$$\begin{aligned} \text{Minimum Price} &= (\text{Market Price of Common Stock} - \text{Exercise Price}) \times \text{Exchange Ratio} \\ &= (\text{₹}10.00 - 11.71) \times 1.0 \\ &= \text{₹}1.71 \end{aligned}$$

(ii) What is the warrant premium?

1 mark

**Answer:**

$$\begin{aligned} \text{Warrant premium} &= \text{Market price of warrant} - \text{Minimum price of warrant} \\ &= \text{₹}3 - 0 \\ &= \text{₹}3 \end{aligned}$$

(iii) Now had the current price of stock been ₹16.375, what is the minimum price and warrant premium? (Consider warrants are tradable at ₹9.75)

2 marks

**Answer:**

Thus, the minimum price on this warrant is considered to be zero, because things simply do not sell for negative prices.

$$\begin{aligned} \text{Minimum Price} &= (\text{Market Price of Common Stock} - \text{Exercise Price}) \times \text{Exchange Ratio} \\ &= (\text{₹}16.375 - 11.71) \times 1.0 \\ &= \text{₹}4.665 \end{aligned}$$

$$\begin{aligned} \text{Warrant premium} &= \text{Market price of warrant} - \text{Minimum price of warrant} \\ &= \text{₹}9.75 - 4.665 \\ &= \text{₹}5.085 \end{aligned}$$

**Example 2**

The Capital Structure of M/s XYZ Ltd., on 31st March, 2016 was as follows:

Particulars	Amount (₹)
Equity Capital (18,000 Shares of ₹100 each)	18,00,000
12% Preference Capital 5,000 Shares of ₹100 each	5,00,000
12% Secured Debentures	5,00,000
Reserves	5,00,000
Profit earned before Interest and Taxes during the year	7,20,000
Tax Rate	40%

Generally, the return on equity shares of this type of Industry is 15%. Subject to:

(a) The profit after tax covers Fixed Interest and Fixed Dividends at least 4 times.

(b) The Debt Equity ratio is at least 2;

(c) Yield on shares is calculated at 60% of distributed profits and 10% of undistributed profits;

The Company has been paying regularly an Equity dividend of 15%.

The risk premium for Dividends is generally assumed at 1%.

Based on the above information, answer the following questions:

(i) Calculate profit after tax.

2 marks

**Answer:**

Particulars	Amount (₹)	Amount (₹)
Profit before interest & tax (PBIT)		7,20,000
Less: Debenture interest ( ` 5,00,000 x 12/100)		60,000
Profit before tax (PBT)		6,60,000
Less: Tax @ 40%		2,64,000
Profit after tax (PAT)		3,96,000
Less: Preference dividend	60,000	

Less: Equity dividend	2,70,000	3,30,000
Retained earnings (undistributed profit)		66,000

(ii) Calculate Interest and Fixed Dividend Coverage Ratio 2 marks

**Answer:**

$$\text{Interest and Fixed Dividend Coverage Ratio} = \frac{\text{PAT} + \text{Debenture Interest}}{\text{Debenture Interest} + \text{Preference Dividend}} = \frac{\text{Rs. } 3,96,000 + 60,000}{\text{Rs. } 60,000 + 60,000} = 3.8 \text{ times}$$

(iii) Calculate Debt-Equity Ratio 2 marks

**Answer:**

$$\text{Debt-Equity Ratio} = \frac{\text{Debt (long term loan)}}{\text{Equity (Shareholders funds)}} = \frac{\text{Rs. } 5,00,000}{\text{Rs. } 5,00,000 + 18,00,000 + 5,00,000} = 0.179 \text{ times}$$

The ratio is less than the industry ratio.

(iv) Compute the Yield on Equity Shares. 2 marks

**Answer:**

Yield on equity shares is calculated at 60% of distributed profits and 10% of undistributed profits:

Particulars	Amount (₹)
60% of distributed profits (60% of ₹ 2,70,000)	1,62,000
10% of undistributed profits (10% of ₹ 66,000)	6,600
	1,68,600

$$\text{Yield on shares} = \frac{\text{Yield on shares}}{\text{Equity share capital}} \times 100$$

$$= \frac{\text{Rs. } 1,68,600}{\text{Rs. } 18,00,000} \times 100$$

$$= 9.37\%$$

(i) Calculate Expected Yield on Equity Shares. 2 marks

**Answer:**

Calculation of Expected Yield on Equity Shares

Normal return expected	15%
Add: Risk premium for low interest and fixed dividend coverage (3.8 < 4)	1%*
Risk for debt equity ratio not required	Nil **
	16%

\* When interest and fixed dividend coverage is lower than the prescribed norm, the riskiness of equity investors is high. They should claim additional risk premium over and above the normal rate of return. Hence, the additional risk premium of 1% has been added.

\*\* The debt equity ratio is lower than the prescribed ratio that means outside funds (Debts) are lower as compared to shareholders' funds. Therefore, the risk is less for equity shareholders. Therefore, no risk premium is required to be added in this case.

(i) Calculate value of Equity Share. 2 marks

**Answer:**

Value of an Equity Share

$$\frac{\text{Actual yield}}{\text{Expected yield}} \times \text{Paid up value of share}$$

$$= \frac{9.37}{16} \times 100$$

$$= ₹58.56$$

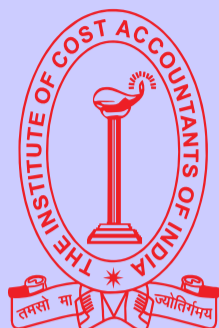

# PRACTICAL Advice

## ABOUT YOUR STUDIES - FINAL COURSE

Practical support, information and advice to help you get the most out of your studies.

START

01

**Read Study Notes,  
MTPs, E-Bulletin,  
Work Books, Attend  
Webinar sessions**

**Solve Exercises  
given in Study Note**

02

03

**Assess Yourself**

**Appear For Examination**

04

FINISHED

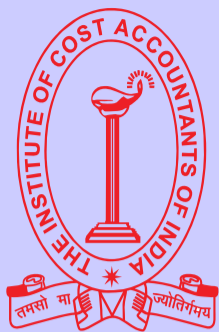

# SUBMISSIONS



Dear Students,

We are very much delighted to receive responses from all of you; for whom our effort is!

We have noted your queries and your requests will definitely be carried out. Further, requesting you to go through the current edition of the bulletin. All the areas will be covered gradually. Expecting your responses further to serve you better as we believe that there is no end of excellence! One of the mails received is acknowledged below.

Please put your opinions so that we can make your e-bulletin everything that you want it to be.

All rights reserved. No part of this Bulletin may be translated or copied in any form or by any means without the prior written permission of the Institute of Cost Accountants of India.

Send your Feedback to:  
e-mail: [studies.ebulletin@icmai.in](mailto:studies.ebulletin@icmai.in)  
website: <http://www.icmai.in>

#### Updation of E-Mail Address/Mobile:

Students are advised to update their E-Mail id and Mobile Numbers timely so that important communications are not missed as the same are sent through bulk mail/SMS nowadays. Student may update their E-Mail id/ Mobile Number instantly after logging into their account at [www.icmai.in](http://www.icmai.in) at request option.



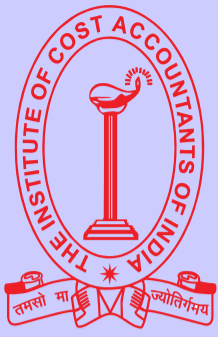

## Message from Directorate of Studies

Dear Students,

We from the Directorate of Studies understand your expectations from us and accordingly we are trying to deliver some meaningful tips through various publications in soft versions like-E-bulletins, Mock Test Papers (MTPs), and we also have conducted Webinar Sessions for the benefit of the students. Supplementary and Amendments are also uploaded from time to time to keep the students updated about the recent changes made in the papers; wherever applicable.

You must be aware that India is celebrating Azadi Ka Amrit Mahotsav, which is an initiative of the Government of India to celebrate and commemorate 75 years of independence and the glorious history of its people, culture and achievements. Along with pan India, your Institute has also observed and took part in various meaningful activities throughout the year. We also expect that our students should also take part in the development of the nation and make the country proud.

***"Freedom has only one motto, may our country be happy and prosperous" .....***

let you all observe the message cited above.

- ❖ Certain general guidelines are listed below and which will help you in preparing for the examinations:
- ❖ Conceptual understanding and overall understanding of the subjects should be clear,
- ❖ Students are advised to go through the study material provided by the Institute meticulously,
- ❖ Students should know and learn the basic understandings of the subjects with focus on core concepts,
- ❖ Students are expected to give to the point answer which is a pre-requisite for any professional examination,
- ❖ To strengthen the answers, students are advised to answer precisely and in the structured manner,
- ❖ Proper time management is also important while answering.

Please refer the link mentioned below:

<https://icmai.in/studentswebsite/index.php>

**GOOD LUCK**  
**Be prepared and be successful**

**Disclaimer:**

Although due care and diligence have been taken in preparation and uploading this E-bulletin, the Institute shall not be responsible for any loss or damage, resulting from any action taken on the basis of the contents of this E-bulletin.



# THE MANAGEMENT ACCOUNTANT



₹300/-  
p.a.  
Twelve Issues

The Journal started its journey in 1966

We have Expanded our Readership to 94 Countries

ISSN 0972-3528

Index Copernicus and J-gate Global Impact and Quality factor [2015]:0.563

## EXPAND YOUR KNOWLEDGE

### Reason to Subscribe & What will you get .....

- ▲ Monthly copy of the Journal at your doorstep
- ▲ Articles on the current topics viz. Finance, Tax Laws, Cost & Management, Economics, Accounts etc
- ▲ News & Developments of the Institute
- ▲ Interviews of eminent personalities
- ▲ Information related to examinations
- ▲ Updates related to newly launched courses and placements
- ▲ The Management Accountant Journal is available on apps for reading through third parties viz. Magzter and Readwhere  
*and many more..*

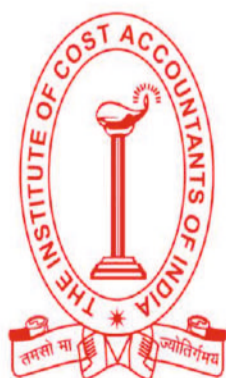

**THE INSTITUTE OF COST ACCOUNTANTS OF INDIA**

Statutory Body under an Act of Parliament

[www.icmai.in](http://www.icmai.in)

Subscribe Now:

[http://icmai-rnj.in/public/journals/254/images/MA\\_Subscription.pdf](http://icmai-rnj.in/public/journals/254/images/MA_Subscription.pdf)

**70%  
DISCOUNT  
FOR CMA  
STUDENTS**

**Toll Free: 1800110910 / 18003450092**

(Mon. to Sat. from 09:30 A.M. to 6.00 P.M.)

Email your subscription queries at [journal@icmai.in](mailto:journal@icmai.in)





# THE INSTITUTE OF COST ACCOUNTANTS OF INDIA

Statutory Body under an Act of Parliament

## Headquarters:

CMA Bhawan, 12 Sudder Street, Kolkata - 700016

## Delhi Office:

CMA Bhawan, 3 Institutional Area, Lodhi Road, New Delhi - 110003

[www.icmai.in](http://www.icmai.in)



# CMA LEADS

**Last Date for Admission**  
June Exam  
31<sup>st</sup> January  
of the same Calendar Year

December Exam  
31<sup>st</sup> July  
of the same Calendar Year

5,00,000<sup>+</sup>  
Students

75,000<sup>+</sup>  
Members

4 Regional  
Councils

98  
Chapters

9  
Overseas  
Centres

Largest  
CMA body  
in Asia

2nd  
Largest  
CMA body  
in the  
Globe

The Institute of Cost Accountants of India is a premier professional Institute and a statutory body constituted under an Act of Parliament under the administrative control of **Ministry of Corporate Affairs (MCA), Govt. of India** to regulate and develop the profession of Cost and Management Accountancy (CMA) in the country. The Institute established in **1944** is now celebrating the **Platinum Jubilee year** of its glorious presence.

## ADMISSIONS OPEN

✉ [studies@icmai.in](mailto:studies@icmai.in)

☎ 1800 345 0092/1800 110 910

For Online Admission

<http://cmaicmai.in/students/Home.aspx>

### Cultivating and Enhancing Skills of Success

- CMA Course Curriculum is designed to meet Industry requirements and challenges in Global Economic Scenario
- Hands on Computer and Soft skills training
- Industry oriented practical training programme
- Six Skill Sets - Knowledge, Comprehension, Application, Analysis, Synthesis and Evaluation
- Four Knowledge Pillars - Management, Strategy, Regulatory Function and Financial Reporting
- Our Motto - Student friendly Syllabus and Industry friendly Students

Excellent Campus Placement Record  
in renowned Public and Private Sector Companies

Highest Salary Offered **Rs.18 Lakh p.a.** | Average Salary **Rs.7.5 Lakh p.a.**

### Few of Our Proud Recruiters



✉ [placement@icmai.in](mailto:placement@icmai.in) / [cpt@icmai.in](mailto:cpt@icmai.in)

☎ + 91 33 40364770

Behind every successful business decision, there is always a **CMA**





# Few Snapshots

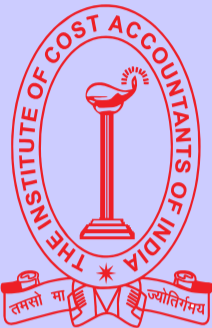

CMA P. Raju Iyer, President along with CMA Vijender Sharma, Vice President of the Institute and CMA B.B. Goyal, Former Addl Chief Advisor (Cost), MoF, GoI extending greetings to Shri Rajnath Singh, Hon'ble Union Minister of Defence on 7th July, 2022.



Glimpses of Observance of GST Day 2022 : GST in India - Poised to deliver Sustainable Growth on 06 July 2022 at Scope Complex, New Delhi



CMA P. Raju Iyer, President along with CMA Vijender Sharma, Vice President of the Institute and CMA B.B. Goyal, Former Addl Chief Advisor (Cost), MoF, GoI extending greetings to Lt. Gen Anil Puri, Additional Secretary, Deptt of Military Affairs, Ministry of Defence on 7th July, 2022.



CMA P. Raju Iyer, President and Prof. Sanghamitra Bandyopadhyay, Director, ISI, Kolkata along with CMA Biswarup Basu, Immediate Past President, CMA Chittaranjan Chattopadhyay, Chairman, BFSI and other dignitaries at a MoU signing ceremony on academic and research collaboration with Indian Statistical Institute (ISI), Kolkata on 13th July, 2022.



CMA P. Raju Iyer, President and Prof. Sanghamitra Bandyopadhyay, Director, ISI, Kolkata along with CMA Biswarup Basu, Immediate Past President, CMA Chittaranjan Chattopadhyay, Chairman, BFSI and other dignitaries at a MoU signing ceremony on academic and research collaboration with Indian Statistical Institute (ISI), Kolkata on 13th July, 2022.



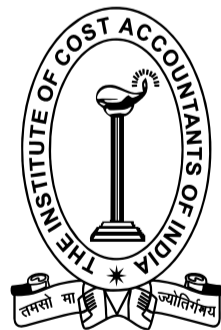

# THE INSTITUTE OF COST ACCOUNTANTS OF INDIA

(Statutory body under an Act of Parliament)

Headquarters: CMA Bhawan, 12, Sunder Street, Kolkata - 700 016

Phone: +91-33-2252-1031/34/35/1602/1492/1619/7373/7143

Delhi office: CMA Bhawan, 3, Institutional Area, Lodhi Road, New Delhi - 110 003

Phone: +91-11-2462-2156/2157/2158

**Behind every successful business decision, there is always a CMA**